

(19) World Intellectual Property Organization  
International Bureau



(43) International Publication Date  
5 July 2007 (05.07.2007)

PCT

(10) International Publication Number  
WO 2007/076393 A2

- (51) International Patent Classification:  
C07C 29/10 (2006.01)
- (21) International Application Number:  
PCT/US2006/062400
- (22) International Filing Date:  
20 December 2006 (20.12.2006)
- (25) Filing Language: English
- (26) Publication Language: English
- (30) Priority Data:  
60/752,974 22 December 2005 (22.12.2005) US
- (71) Applicant (for SM only): SHELL OIL COMPANY  
[US/US]; One Shell Plaza, P.O. Box 2463, Houston, Texas  
77252-2463 (US).
- (71) Applicant (for all designated States except US): SHELL  
INTERNATIONALE RESEARCH MAATSCHAPPIJ  
B.V. [NL/NL]; Carel van Bylandtlaan 30, NL-2596 HR The  
Hague (NL).
- (72) Inventors; and
- (75) Inventors/Applicants (for US only): BOLK, Jeroen,  
Willem [NL/NL]; Badhuisweg 3, NL-1031 CM Amster-  
dam (NL). BOS, Alouisius, Nicolaas, Renée [NL/NL];  
Badhuisweg 3, NL-1031 CM Amsterdam (NL). EVANS,  
Wayne, Errol [US/US]; 1019 Lively Court, Richmond,  
Texas 77469 (US). LOCKEMEYER, John, Robert  
[US/US]; 3403 Stoney Mist Drive, Sugar Land, Texas

- 77479 (US). MCALLISTER, Paul, Michael [US/US];  
1422 Allston, Houston, Texas 77008 (US). RAMAKERS,  
Bernardus, Franciscus, Josef, Marie [NL/NL]; Bad-  
huisweg 3, NL-1031 CM Amsterdam (NL). REKERS,  
Dominicus, Maria [NL/NL]; Badhuisweg 3, NL-1031  
CM Amsterdam (NL). SLAPAK, Mathias, Jozef, Paul  
[NL/NL]; Badhuisweg 3, NL-1031 CM Amsterdam (NL).
- (74) Agent: LUNDELL, Craig, M.; SHELL OIL COMPANY,  
One Shell Plaza, P.O. Box 2463, Houston, Texas 77252-  
2463 (US).
- (81) Designated States (unless otherwise indicated, for every  
kind of national protection available): AE, AG, AL, AM,  
AT, AU, AZ, BA, BB, BG, BR, BW, BY, BZ, CA, CH, CN,  
CO, CR, CU, CZ, DE, DK, DM, DZ, EC, EE, EG, ES, FI,  
GB, GD, GE, GH, GM, GT, HN, HR, HU, ID, IL, IN, IS,  
JP, KE, KG, KM, KN, KP, KR, KZ, LA, LC, LK, LR, LS,  
LT, LU, LV, LY, MA, MD, MG, MK, MN, MW, MX, MY,  
MZ, NA, NG, NI, NO, NZ, OM, PG, PH, PL, PT, RO, RS,  
RU, SC, SD, SE, SG, SK, SL, SM, SV, SY, TJ, TM, TN,  
TR, TT, TZ, UA, UG, US, UZ, VC, VN, ZA, ZM, ZW.
- (84) Designated States (unless otherwise indicated, for every  
kind of regional protection available): ARIPO (BW, GH,  
GM, KE, LS, MW, MZ, NA, SD, SL, SZ, TZ, UG, ZM,  
ZW), Eurasian (AM, AZ, BY, KG, KZ, MD, RU, TJ, TM),  
European (AT, BE, BG, CH, CY, CZ, DE, DK, EE, ES, FI,  
FR, GB, GR, HU, IE, IS, IT, LT, LU, LV, MC, NL, PL, PT,

[Continued on next page]

(54) Title: A PROCESS FOR THE PREPARATION OF A CHEMICAL DERIVABLE FROM AN OLEFIN OXIDE, AND A REACTOR SUITABLE FOR SUCH A PROCESS

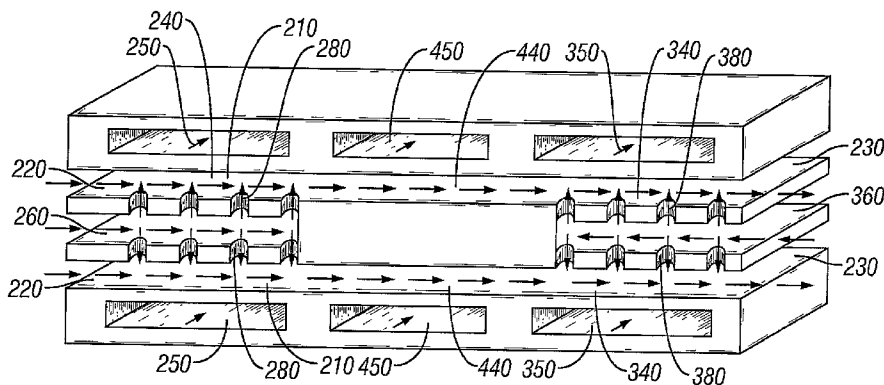

(57) Abstract: The present invention relates to an improved epoxidation process and an improved epoxidation reactor. The present invention makes use of a reactor which comprises a plurality of microchannels. Such process microchannels may be adapted such that the epoxidation and optionally other processes can take place in the microchannels and that they are in a heat exchange relation with channels adapted to contain a heat exchange fluid. A reactor comprising such process microchannels is referred to as a "microchannel reactor". The invention provides a certain process for the epoxidation of an olefin and a process for the preparation of a chemical derivable from an olefin oxide. The invention also provides a microchannel reactor.

WO 2007/076393 A2



RO, SE, SI, SK, TR), OAPI (BF, BJ, CF, CG, CI, CM, GA, GN, GQ, GW, ML, MR, NE, SN, TD, TG).

*For two-letter codes and other abbreviations, refer to the "Guidance Notes on Codes and Abbreviations" appearing at the beginning of each regular issue of the PCT Gazette.*

**Published:**

— *without international search report and to be republished upon receipt of that report*

A PROCESS FOR THE PREPARATION OF A CHEMICAL DERIVABLE FROM AN  
OLEFIN OXIDE, AND A REACTOR SUITABLE FOR SUCH A PROCESS

Field of the Invention

5           The invention relates to a process for the preparation of a chemical derivable from an olefin oxide. In particular, such a chemical may be a 1,2-diol. The invention also relates to a reactor which is suitable for use in such a process.

Background of the Invention

10           Ethylene oxide and other olefin oxides are important industrial chemicals used as a feedstock for making such chemicals as ethylene glycol, propylene glycol, ethylene glycol ethers, ethylene carbonate, ethanol amines and detergents. One method for manufacturing an olefin oxide is by olefin epoxidation, that is the catalyzed partial oxidation of the olefin with oxygen yielding the olefin oxide. The olefin oxide so manufactured may be reacted with water, an alcohol, carbon dioxide, or an amine to produce a 1,2-diol, a 1,2-diol ether, 15 a 1,2-carbonate or an alkanol amine. Such production of a 1,2-diol, a 1,2-diol ether, a 1,2-carbonate or an alkanol amine is generally carried out separately from the manufacture of the olefin oxide, in any case the two processes are normally carried out in separate reactors.

          In olefin epoxidation, a feed containing the olefin and oxygen is passed over a bed of catalyst contained within a reaction zone that is maintained at certain reaction 20 conditions. A commercial epoxidation reactor is generally in the form of a shell-and-tube heat exchanger, in which a plurality of substantially parallel elongated, relatively narrow tubes are filled with shaped catalyst particles to form a packed bed, and in which the shell contains a coolant. Irrespective of the type of epoxidation catalyst used, in commercial operation the internal tube diameter is frequently in the range of from 20 to 40 mm, and the 25 number of tubes per reactor may range in the thousands, for example up to 12,000.

          Olefin epoxidation is generally carried out with a relatively low olefin conversion and oxygen conversion. Recycle of unconverted olefin and oxygen is normally applied in order to enhance the economics of the process. Generally the feed additionally comprises a large quantity of so-called ballast gas to facilitate operation outside the explosion limits. 30 Ballast gas includes saturated hydrocarbons, in particular methane and ethane. As a consequence, recycling generally involves the handling of large quantities of process streams, which includes the unconverted olefin, unconverted oxygen and the ballast gas. The processing of the recycle stream as normally applied in an olefin epoxidation plant is also fairly complex, as it involves olefin oxide recovery, carbon dioxide removal, water

removal and re-pressurizing. The use of ballast gas not only contributes to the cost of processing, it also reduces the epoxidation reaction rate.

The epoxidation catalyst generally contains the catalytically active species, typically a Group 11 metal (in particular silver) and promoter components, on a shaped carrier material. Shaped carrier materials are generally carefully selected to meet requirements of, for example, strength and resistance against abrasion, surface area and porosity. The shaped carrier materials are generally manufactured by sintering selected inorganic materials to the extent that they have the desired properties.

During the epoxidation, the catalyst is subject to a performance decline, which represents itself by a loss in activity of the catalyst and selectivity in the formation the desired olefin oxide. In response to the loss of activity, the epoxidation reaction temperature may be increased such that the production rate of the olefin oxide is maintained. The operation of commercial reactors is normally limited with respect to the reaction temperature and when the applicable temperature limit has been reached, the production of the olefin oxide has to be interrupted for an exchange of the existing charge of epoxidation catalyst for a fresh charge.

It would be of great value if improved epoxidation processes and improved epoxidation reactors would become available.

#### Summary of the Invention

The present invention provides such improved epoxidation processes and improved epoxidation reactors. Embodiments of the present invention make use of a reactor which comprises a plurality of microchannels ("process microchannels" hereinafter). The process microchannels may be adapted such that the epoxidation and optionally other processes can take place in the microchannels and that they are in a heat exchange relation with channels adapted to contain a heat exchange fluid ("heat exchange channels" hereinafter). A reactor comprising process microchannels is referred to herein by using the term "microchannel reactor". As used herein, the term "Group 11" refers to Group 11 of the Periodic Table of the Elements.

In an embodiment, the invention provides a process for the preparation of a 1,2-diol, which process comprises

- reacting a feed comprising an olefin and oxygen in the presence an epoxidation catalyst contained in a first section of one or more process microchannels of a microchannel reactor to form an olefin oxide,

- converting the olefin oxide with carbon dioxide to form a 1,2-carbonate in a second section of the one or more process microchannels positioned downstream of the first section, and
- converting the 1,2-carbonate with water or an alcohol to form the 1,2-diol in a third section of the one or more process microchannels positioned downstream of the second section.

5           In another embodiment, the invention provides a process for the preparation of a 1,2-diol, which process comprises converting in one or more process microchannels of a microchannel reactor a 1,2-carbonate with water or an alcohol to form the 1,2-diol.

          In another embodiment, the invention provides a reactor suitable for the preparation of a 1,2-diol, which reactor is a microchannel reactor comprising

10   one or more process microchannels comprising

- an upstream end,
- a downstream end,
- a first section which is adapted to contain an epoxidation catalyst, to receive a feed comprising an olefin and oxygen, and to cause conversion of at least a portion of the feed to

15   form an olefin oxide in the presence of the epoxidation catalyst,

- a second section positioned downstream of the first section which is adapted to receive the olefin oxide, to receive carbon dioxide, and to cause conversion of the olefin oxide to form a 1,2-carbonate, and
- a third section positioned downstream of the first section which is adapted to receive the 1,2-

20   carbonate, to receive water or an alcohol, and to cause conversion of the 1,2-carbonate to form a 1,2-diol.

          The reactor of the latter embodiment may comprise additionally one or more first heat exchange channels adapted to exchange heat with the first section of the said process microchannels, one or more second heat exchange channels adapted to exchange heat with the

25   second section of the said process microchannels, and one or more third heat exchange channels adapted to exchange heat with the third section of the said process microchannels.

          Further, the one or more process microchannels may comprise additionally a first intermediate section downstream from the first section and upstream from the second section, which first intermediate section is adapted to control the temperature of the olefin oxide, and a

30   second intermediate section downstream from the second section and upstream from the third section, which second intermediate section is adapted to control the temperature of the 1,2-carbonate.

In particular, the reactor may comprise additionally one or more fourth heat exchange channels adapted to exchange heat with the first intermediate section of the said process microchannels, and one or more fifth heat exchange channels adapted to exchange heat with the second intermediate section of the said process microchannels.

5 Description of the Drawings

FIG. 1 shows a schematic of a microchannel reactor and its main constituents.

FIG. 2 shows a schematic of a typical example of a repeating unit which comprises process microchannels and heat exchange channels and its operation when in use in the practice of the invention. A microchannel reactor of this invention may comprise a  
10 plurality of such repeating units.

Detailed Description of the Invention

The use of a microchannel reactor in accordance with this invention leads to one or more of the following advantages:

- 15 - the epoxidation catalyst does not necessarily involve the use a shaped carrier, which can eliminate the need for a step for producing a shaped carrier.
- quenching of the olefin oxide inside the process microchannel enables operation under conditions which may be within explosion limits when such conditions would be applied in a conventional shell-and-tube heat exchanger reactor. Such conditions may be achieved by contacting an oxygen rich feed component with an olefin rich feed component within the  
20 process microchannels, which oxygen rich feed component and olefin rich feed component are normally outside the explosion limits. Quenching inside the process microchannels also decreases the formation of byproducts, such as aldehydes and carboxylic acids.
- the epoxidation within the process microchannels can advantageously be carried out at conditions of high total concentration of the olefin, oxygen and the olefin oxide, which can  
25 lead to a higher epoxidation rate and/or lower epoxidation reaction temperature. Lowering the epoxidation reaction temperature can lead to improved selectivity and improved catalyst life. Employing conditions of high total concentration of the olefin, oxygen and the olefin oxide can also eliminate the need of using a ballast gas, which provides more efficient processing and reduction of the costs of recycling.
- 30 - the epoxidation carried out in process microchannels may be operated at a high conversion level of oxygen or the olefin oxide. In particular when the process is carried out at a high olefin conversion level, it is advantageous to operate the epoxidation process in once-through operation, which implies that no recycle stream is applied. In addition, it is advantageous that

in such case air may be fed to the process microchannels, instead of oxygen separated from air, which can eliminate the need for an air separation unit.

- carrying out the olefin epoxidation inside the process microchannels enables conversion of the formed olefin oxide inside the same process microchannels to 1,2-diol. This can eliminate the need for additional reactors for such further conversion. It can also eliminate the need for an olefin oxide recovering unit and/or a carbon dioxide removal unit, and it can reduce the need for heat exchanging equipment. Hence, it can reduce the complexity of the additional processing conventionally applied in a manufacturing plant, for example for product recovery. Conversion of the olefin oxide inside the process microchannels also decreases the formation of byproducts, such as aldehydes and carboxylic acids.

Microchannel reactors suitable for use in this invention and their operation have been described in WO-A-2004/099113, WO-A-01/12312, WO-01/54812, US-A-6440895, US-A-6284217, US-A-6451864, US-A-6491880, US-A-6666909, US-6811829, US-A-6851171, US-A-6494614, US-A-6228434 and US-A-6192596, which are incorporated herein by reference. Methods by which the microchannel reactor may be manufactured, loaded with catalyst and operated, as described in these references, may generally be applicable in the practice of the present invention.

With reference to FIG. 1, microchannel reactor 100 may be comprised of a process header 102, a plurality of process microchannels 104, and a process footer 108. The process header 102 provides a passageway for fluid to flow into the process microchannels 104. The process footer 108 provides a passageway for fluid to flow from the process microchannels 104.

The number of process microchannels contained in a microchannel reactor may be very large. For example, the number may be up to  $10^5$ , or even up to  $10^6$  or up to  $2 \times 10^6$ . Normally, the number of process microchannels may be at least 10 or at least 100, or even at least 1000.

The process microchannels are typically arranged in parallel, for example they may form an array of planar microchannels. The process microchannels may have at least one internal dimension of height or width of up to 15 mm, for example from 0.05 to 10 mm, in particular from 0.1 to 5 mm, more in particular from 0.5 to 2 mm. The other internal dimension of height or width may be, for example, from 0.1 to 100 cm, in particular from 0.2 to 75 cm, more in particular from 0.3 to 50 cm. The length of the process

microchannels may be, for example, from 1 to 500 cm, in particular from 2 to 300 cm, more in particular from 3 to 200 cm, or from 5 to 100 cm.

The microchannel reactor 100 additionally comprises heat exchange channels (not shown in FIG. 1) which are in heat exchange contact with the process microchannels 104.

5 The heat exchange channels may also be microchannels. The microchannel reactor is adapted such that heat exchange fluid can flow from heat exchange header 110 through the heat exchange channels to heat exchange footer 112. The heat exchange channels may be aligned to provide a flow in a co-current, counter-current or, preferably, cross-current direction, relative to a flow in the process microchannels 104. The cross-current direction  
10 is as indicated by arrows 114 and 116.

The heat exchange channels may have at least one internal dimension of height or width of up to 15 mm, for example from 0.05 to 10 mm, in particular from 0.1 to 5 mm, more in particular from 0.5 to 2 mm. The other internal dimension of height or width may be, for example, from 0.1 to 100 cm, in particular from 0.2 to 75 cm, more in particular  
15 from 0.3 to 50 cm. The length of the heat exchange channels may be, for example, from 1 to 500 cm, in particular from 2 to 300 cm, more in particular from 3 to 200 cm, or from 5 to 100 cm.

The separation between a process microchannel 104 and the next adjacent heat exchange channel may be in the range of from 0.05 mm to 5 mm, in particular from 0.2 to  
20 2 mm.

In some embodiments of this invention, there is provided for first heat exchange channels and second heat exchange channels, or first heat exchange channels, second heat exchange channels and third heat exchange channels, or even up to fifth heat exchange channels, or even further heat exchange channels. Thus, in such cases, there is a plurality  
25 of sets of heat exchange channels, and accordingly there may be a plurality of heat exchange headers 110 and heat exchange footers 112, whereby the sets of heat exchange channels may be adapted to receive heat exchange fluid from a heat exchange header 110 and to deliver heat exchange fluid into a heat exchange footer 112.

The process header 102, process footer 108, heat exchange header 110, heat  
30 exchange footer 112, process microchannels 104 and heat exchange channels may independently be made of any construction material which provides sufficient strength, dimensional stability and heat transfer characteristics to permit operation of the processes in accordance with this invention. Suitable construction materials include, for example,



steel (for example stainless steel and carbon steel), monel, titanium, copper, glass and polymer compositions. The kind of heat exchange fluid is not material to the present invention and the heat exchange fluid may be selected from a large variety. Suitable heat exchange fluids include steam, water, air and oils. In embodiments of the invention which include a plurality of sets of heat exchange channels, such sets of heat exchange channels may operate with different heat exchange fluids or with heat exchange fluids having different temperatures.

A microchannel reactor according to the invention may comprise a plurality of repeating units comprising one or more process microchannels and one or more heat exchange channels. Reference is now made to FIG. 2, which shows a typical repeating unit and its operation.

Process microchannels 210 have an upstream end 220 and a downstream end 230 and may comprise of a first section 240 which may contain a catalyst (not drawn), for example an epoxidation catalyst. First section 240 may be in heat exchange contact with first heat exchange channel 250, allowing heat exchange between first section 240 of process microchannel 210 and first heat exchange channel 250. The repeating unit may comprise first feed channel 260 which ends into first section 240 through one or more first orifices 280. Typically one or more first orifices 280 may be positioned downstream relative to another first orifice 280. During operation, feed comprising the olefin and oxygen may enter into first section 240 of process microchannel 210 through an opening in upstream end 220 and/or through first feed channel 260 and one or more first orifices 280.

Process microchannels 210 may comprise a second section 340 which may or may not be adapted to contain a catalyst, in particular a catalyst which is suitable for the conversion of olefin oxide to 1,2-carbonate. Second section 340 may or may not contain a catalyst, as described herein. Second section 340 is positioned downstream of first section 240. Second section 340 may be in heat exchange contact with second heat exchange channel 350, allowing heat exchange between second section 340 of process microchannel 210 and second heat exchange channel 350. The repeating unit may comprise second feed channel 360 which ends into second section 340 through one or more second orifices 380. During operation, feed may enter into second section 340 from upstream in process microchannel 210 and through second feed channel 360 and one or more second orifices 380. Typically one or more second orifices 380 may be positioned downstream relative to another second orifice 380. Second section 340 is adapted for accommodating conversion

of olefin oxide to 1,2-carbonate. Feed entering during operation through second feed channel 360 and one or more second orifices 380 may comprise carbon dioxide. Also, catalyst may be fed through second feed channel 360 and one or more second orifices 380. If desirable, a separate set of second feed channel (not drawn) with one or more second orifices (not drawn) may be present in order to accommodate separate feeding of feed and catalyst.

The first and second feed channels 260 or 360 in combination with first and second orifices 280 or 380, whereby one or more first or second orifices 280 or 380 are positioned downstream to another first or second orifice 280 or 380, respectively, allow for replenishment of a reactant. Replenishment of a reactant is a feature in some embodiments of this invention.

Process microchannels 210 may comprise an intermediate section 440, which is positioned downstream of first section 240 and upstream of second section 340. Intermediate section 440 may be in heat exchange contact with third heat exchange channel 450, allowing heat exchange between intermediate section 440 of process microchannel 210 and third heat exchange channel 450. In some embodiments intermediate section 440 is adapted to quench olefin oxide obtained in and received from first section 240 by heat exchange with a heat exchange fluid in third heat exchange channel 450. Quenching may be achieved in stages by the presence of a plurality of third heat exchange channels 450, for example two or three or four. Such a plurality of third heat exchange channels 450 may be adapted to contain heat exchange fluids having different temperatures, in particular such that in downstream direction of intermediate section 440 heat exchange takes place with a third heat exchange channel 450 containing a heat exchange fluid having a lower temperature.

In some embodiments, process microchannel 210 may comprise a third section (not drawn) downstream of second section 340, and optionally a second intermediate section (not drawn) downstream of second section 340 and upstream of the third section. The third section may or may not be adapted to contain a catalyst. The third section may or may not contain a catalyst, in particular a catalyst which is suitable for the conversion of an olefin oxide into a 1,2-carbonate. The third section may be in heat exchange contact with a fourth heat exchange channel (not drawn), allowing heat exchange between the third section of the process microchannel 210 and fourth heat exchange channel. The second intermediate section may be in heat exchange contact with a fifth heat exchange channel (not drawn),

allowing heat exchange between the second intermediate section of the process microchannel 210 and fifth heat exchange channel. The repeating unit may comprise a third feed channel (not drawn) which ends into the third section through one or more third orifices (not drawn). Typically one or more third orifices may be positioned downstream relative to another third orifice. During operation, feed may enter into the third section from upstream in process microchannel 210 and through the third feed channel and the one or more third orifices. The third section is adapted for accommodating conversion of 1,2-carbonate into 1,2-diol. Feed entering during operation through the third feed channel and the one or more third orifices may comprise water, an alcohol, or an alcohol/water mixture. Also, catalyst may be fed through the third feed channel and the one or more third orifices. If desirable, a separate set of third feed channels (not drawn) with one or more third orifices (not drawn) may be present in order to accommodate separate feeding of feed and catalyst.

The feed channels may be microchannels. They may have at least one internal dimension of height or width of up to 15 mm, for example from 0.05 to 10 mm, in particular from 0.1 to 5 mm, more in particular from 0.5 to 2 mm. The other internal dimension of height or width may be, for example, from 0.1 to 100 cm, in particular from 0.2 to 75 cm, more in particular from 0.3 to 50 cm. The length of the feed channels may be, for example, from 1 to 250 cm, in particular from 2 to 150 cm, and more particularly from 3 to 100 cm, or from 5 to 50 cm.

The length of the sections of the process microchannels may be selected independently of each other, in accordance with, for example, the heat exchange capacity needed or the quantity of catalyst which may be contained in the section. The lengths of the sections are preferably at least 1 cm, or at least 2 cm, or at least 5 cm. The lengths of the sections are preferably at most 250 cm, or at most 150 cm, or at most 100 cm, or at most 50 cm. Other dimensions of the sections are dictated by the corresponding dimensions of process microchannel 210.

The microchannel reactor of this invention may be manufactured using known techniques, for example conventional machining, laser cutting, molding, stamping and etching and combinations thereof. The microchannel reactor of this invention may be manufactured by forming sheets with features removed which allow passages. A stack of such sheets may be assembled to form an integrated device, by using known techniques, for example diffusion bonding, laser welding, cold welding, diffusion brazing, and

combinations thereof. The microchannel reactor of this invention comprises appropriate headers, footers, valves, conduit lines, and other features to control input of reactants, output of product, and flow of heat exchange fluids. These are not shown in the drawings, but they can be readily provided by those skilled in the art. Also, there may be further heat exchange equipment (not shown in the drawings) for temperature control of feed, in particular for heating feed or feed components, before it enters the process microchannels, or for temperature control of product, in particular for quenching product, after it has left the process microchannels. Such further heat exchange equipment may be integral with the microchannel reactor, but more typically it will be separate equipment. These are not shown in the drawings, but they can be readily provided by those skilled in the art. Heat integration may be applied, for example by using reaction heat of the epoxidation process for heating feed components, or for other heating purposes.

Typically, the epoxidation catalysts are solid catalysts under the conditions of the epoxidation reaction. Such epoxidation catalyst, and any other solid catalysts as appropriate, may be installed by any known technique in the designated section of the process microchannels. The catalysts may form a packed bed in the designated section of the process microchannel and/or they may form a coating on at least a portion of the wall of the designated section of the process microchannels. The skilled person will understand that the coating will be positioned on the interior wall of the process microchannels. Alternatively or additionally, one or more of the catalysts may be in the form of a coating on inserts which may be placed in the designated section of the process microchannels. Coatings may be prepared by any deposition method, such as wash coating or vapor deposition. In some embodiments, the epoxidation catalyst may not be a solid catalyst under the conditions of the epoxidation, in which case the epoxidation catalyst may be fed to the designated section of the process microchannels together with one or more components of the epoxidation feed and may pass through the process microchannels along with the epoxidation reaction mixture.

The epoxidation catalyst which may be used in this invention is typically a catalyst which comprises one or more Group 11 metals. The Group 11 metals may be selected from the group consisting of silver and gold. Preferably, the Group 11 metal comprises silver. In particular, the Group 11 metal comprises silver in a quantity of at least 90 %w, more in particular at least 95 %w, for example at least 99 %w, or at least 99.5 %w, calculated as the weight of silver metal relative to the total weight of the Group 11 metal,

as metal. Typically, the epoxidation catalyst additionally comprises one or more promoter components. More typically, the epoxidation catalyst comprises the Group 11 metal, one or more promoter components and additionally one or more components comprising one or more further elements. In some embodiments, the epoxidation catalyst may comprise a  
5 carrier material on which the Group 11 metal, any promoter components and any components comprising one or more further elements may be deposited. Suitable promoter components and suitable components comprising one or more further elements and suitable carrier materials may be as described hereinafter.

In an embodiment, a method of installing an epoxidation catalyst in one or more  
10 process microchannels of a microchannel reactor comprises introducing into the one or more process microchannels a dispersion of the epoxidation catalyst dispersed in an essentially non-aqueous diluent, and removing the diluent.

The essentially non-aqueous diluent may be a liquid, or it may be in a gaseous form. As used herein, for liquid diluents, "essentially non-aqueous" means that the water content of  
15 the diluent is at most 20 %w, in particular at most 10 %w, more in particular at most 5 %w, for example at most 2 %w, or even at most 1 %w, or at most 0.5 %w, relative to the weight of the diluent. In particular, for gaseous diluents, "essentially non-aqueous" means that the diluent as present in the process microchannels is above the dew point. The substantial or complete  
20 absence of liquid water in the diluent enables the catalyst to better maintain its integrity during installation, in terms of one or more of its morphology, composition and properties, than when an aqueous diluent is applied. Suitable essentially non-aqueous liquid diluents include organic diluents, for example hydrocarbons, halogenated hydrocarbons, alcohols, ketones, ethers, and esters. Suitable alcohols include, for example methanol and ethanol. The quantity of catalyst which may be present in the liquid diluent may be in the range of from 1 to 50 %w, in  
25 particular from 2 to 30 %w, relative to the weight of the total of the catalyst and the liquid diluent.

Suitable essentially non-aqueous gaseous phase diluents include, for example, air, nitrogen, argon and carbon dioxide. The quantity of catalyst which may be present in the  
30 gaseous phase diluent may be in the range of from 10 to 500 g/l, in particular from 22 to 300 g/l, calculated as the weight of catalyst relative to the volume of the gaseous phase diluent.

The epoxidation catalyst present in the dispersion may be obtained by crushing a conventional, shaped catalyst and optionally followed by sieving. The particle size of the catalyst present in the dispersion is typically such that  $d_{50}$  is in the range of from 0.1 to 100  $\mu\text{m}$ ,

in particular from 0.5 to 50  $\mu\text{m}$ . As used herein, the average particle size, referred to herein as "d<sub>50</sub>", is as measured by a Horiba LA900 particle size analyzer and represents a particle diameter at which there are equal spherical equivalent volumes of particles larger and particles smaller than the stated average particle size. The method of measurement includes dispersing the particles by ultrasonic treatment, thus breaking up secondary particles into primary particles. This sonification treatment is continued until no further change in the d<sub>50</sub> value is noticed, which typically requires 5 minute sonification when using the Horiba LA900 particle size analyzer. Preferably, the epoxidation catalyst comprises particles having dimensions such that they pass a sieve with openings sized at at most 50 %, in particular at most 30 % of the smallest dimension of the process microchannel.

Conventional, shaped epoxidation catalysts typically comprise Group 11 metal, one or more promoter components and optionally one or more components comprising a further element dispersed on a shaped carrier material. Suitable carrier materials, suitable promoter components, suitable components comprising a further element and suitable catalyst compositions in respect of the quantities of Group 11 metal, promoter components and components comprising a further element may be as described hereinafter.

Alternatively, and preferably, the epoxidation catalyst present in the dispersion is prepared as described herein.

The dispersion of the catalyst may be introduced such that a packed catalyst bed is formed in the designated section of one or more of the process microchannels, or alternatively such that at least a portion of the walls of the said sections is covered with the catalyst. In the former case, prior to introducing the dispersion of the catalyst, a support device, for example a sieve or a graded particulate material, may have been placed in the downstream portion of the designated section of the one or more of the process microchannels, to support the catalyst and to prevent it from moving further downstream. In the latter case, the catalyst may be deposited on the walls of the process microchannels prior to or after assembling the process microchannels, or the catalyst may be present on inserts placed in the designated section of the process microchannels.

The total quantity of Group 11 metal present in the first section of the process microchannels is not material to the invention, and may be selected within wide ranges. Typically, the total quantity of Group 11 metal may be in the range of from 10 to 500  $\text{kg}/\text{m}^3$ , more typically from 50 to 400  $\text{kg}/\text{m}^3$ , in particular from 100 to 300  $\text{kg}/\text{m}^3$  reactor volume, wherein reactor volume is the total volume defined by the cross sectional

area and the total length of the portions of the process microchannels which is occupied by the epoxidation catalyst, by presence of a packed bed and/or by the presence of the epoxidation catalyst on the wall. For the avoidance of doubt, the reactor volume so defined does not include portions of the process microchannel which do not comprise epoxidation catalyst. In embodiments of the invention wherein the feed comprises the olefin and oxygen in a total quantity of at least 50 mole-%, the total quantity of Group 11 metal may be in the range of from 5 to 250 kg/m<sup>3</sup>, more typically from 20 to 200 kg/m<sup>3</sup>, in particular from 50 to 150 kg/m<sup>3</sup> reactor volume, as defined hereinbefore.

In an embodiment, the invention provides a method of preparing a particulate epoxidation catalyst, which method comprises depositing Group 11 metal and one or more promoter components on a particulate carrier material having a pore size distribution such that pores with diameters in the range of from 0.2 to 10 μm represent at least 70 % of the total pore volume.

The carrier materials for use in this invention may be natural or artificial inorganic materials and they may include refractory materials, silicon carbide, clays, zeolites, charcoal and alkaline earth metal carbonates, for example calcium carbonate. Preferred are refractory materials, such as alumina, magnesia, zirconia and silica. The most preferred material is α-alumina. Typically, the carrier material comprises at least 85 %w, more typically at least 90 %w, in particular at least 95 %w α-alumina, frequently up to 99.9 %w α-alumina, relative to the weight of the carrier. Other components of the α-alumina may comprise, for example, silica, alkali metal components, for example sodium and/or potassium components, and/or alkaline earth metal components, for example calcium and/or magnesium components.

The surface area of the carrier material may suitably be at least 0.1 m<sup>2</sup>/g, preferably at least 0.3 m<sup>2</sup>/g, more preferably at least 0.5 m<sup>2</sup>/g, and in particular at least 0.6 m<sup>2</sup>/g, relative to the weight of the carrier; and the surface area may suitably be at most 10 m<sup>2</sup>/g, preferably at most 5 m<sup>2</sup>/g, and in particular at most 3 m<sup>2</sup>/g, relative to the weight of the carrier. "Surface area" as used herein is understood to relate to the surface area as determined by the B.E.T. (Brunauer, Emmett and Teller) method as described in Journal of the American Chemical Society 60 (1938) pp. 309-316. High surface area carrier materials, in particular when they are an α-alumina optionally comprising in addition silica, alkali metal and/or alkaline earth metal components, provide improved performance and stability of operation.

The water absorption of the carrier material is typically in the range of from 0.2 to 0.8 g/g, preferably in the range of from 0.3 to 0.7 g/g. A higher water absorption may be in favor in view of a more efficient deposition of Group 11 metal, promoter components and components comprising one or more elements. As used herein, water absorption is as  
5 measured in accordance with ASTM C20, and water absorption is expressed as the weight of the water that can be absorbed into the pores of the carrier, relative to the weight of the carrier.

The particulate carrier material may have a pore size distribution such that pores with diameters in the range of from 0.2 to 10  $\mu\text{m}$  represent at least 70 % of the total pore volume. Such relatively narrow pore size distribution can contribute to one or more of the activity,  
10 selectivity and longevity of the catalyst. Longevity may be in respect of maintaining the catalyst activity and/or maintaining the selectivity. As used herein, the pore size distribution and the pore volumes are as measured by mercury intrusion to a pressure of  $3.0 \times 10^8$  Pa using a Micromeritics Autopore 9200 model ( $130^\circ$  contact angle, mercury with a surface tension of 0.473 N/m, and correction for mercury compression applied).

Preferably, the pore size distribution is such that the pores with diameters in the range of from 0.2 to 10  $\mu\text{m}$  represent more than 75 %, in particular more than 80 %, more preferably more than 85 %, most preferably more than 90 % of the total pore volume. Frequently, the pore size distribution is such that the pores with diameters in the range of from 0.2 to 10  $\mu\text{m}$  represent less than 99.9 %, more frequently less than 99 % of the total  
20 pore volume.

Preferably, the pore size distribution is such that the pores with diameters in the range of from 0.3 to 10  $\mu\text{m}$  represent more than 75 %, in particular more than 80 %, more preferably more than 85 %, most preferably more than 90 %, in particular up to 100 %, of the pore volume contained in the pores with diameters in the range of from 0.2 to 10  $\mu\text{m}$ .

Typically, the pore size distribution is such that pores with diameters less than 0.2  $\mu\text{m}$  represent less than 10 %, in particular less than 5 %, of the total pore volume. Frequently, the pores with diameters less than 0.2  $\mu\text{m}$  represent more than 0.1 %, more frequently more than 0.5 % of the total pore volume.

Typically, the pore size distribution is such that pores with diameters greater than  
30 10  $\mu\text{m}$  represent less than 20 %, in particular less than 10 %, more in particular less than 5 %, of the total pore volume. Frequently, the pores with diameters greater than 10  $\mu\text{m}$  represent more than 0.1 %, in particular more than 0.5 % of the total pore volume.



The epoxidation catalyst which comprises one or more Group 11 metals dispersed on a carrier material exhibits appreciable catalytic activity when the Group 11 metal content is at least 10 g/kg, relative to the weight of the catalyst. Preferably, the catalyst comprises Group 11 metal in a quantity of from 50 to 500 g/kg, more preferably from 100 to 400 g/kg.

The promoter component may comprise one or more elements selected from rhenium, tungsten, molybdenum, chromium, and mixtures thereof. Preferably the promoter component comprises, as one of its elements, rhenium.

The promoter component may typically be present in the epoxidation catalyst in a quantity of at least 0.05 mmole/kg, more typically at least 0.5 mmole/kg, and preferably at least 1 mmole/kg, calculated as the total quantity of the element (that is rhenium, tungsten, molybdenum and/or chromium) relative to the weight of Group 11 metal. The promoter component may be present in a quantity of at most 250 mmole/kg, preferably at most 50 mmole/kg, more preferably at most 25 mmole/kg, calculated as the total quantity of the element relative to the weight of Group 11 metal. The form in which the promoter component may be deposited is not material to the invention. For example, the promoter component may suitably be provided as an oxide or as an oxyanion, for example, as a rhenate, perrhenate, or tungstate, in salt or acid form.

When the epoxidation catalyst comprises a rhenium containing promoter component, rhenium may typically be present in a quantity of at least 0.5 mmole/kg, more typically at least 2.5 mmole/kg, and preferably at least 5 mmole/kg, in particular at least 7.5 mmole/kg, calculated as the quantity of the element relative to the weight of Group 11 metal. Rhenium is typically present in a quantity of at most 25 mmole/kg, preferably at most 15 mmole/kg, more preferably at most 10 mmole/kg, in particular at most 7.5 mmole/kg, on the same basis.

Further, when the epoxidation catalyst comprises a rhenium containing promoter component, the catalyst may preferably comprise a rhenium copromoter, as a further component deposited on the carrier. Suitably, the rhenium copromoter may be selected from components comprising an element selected from tungsten, chromium, molybdenum, sulfur, phosphorus, boron, and mixtures thereof. Preferably, the rhenium copromoter is selected from components comprising tungsten, chromium, molybdenum, sulfur, and mixtures thereof. It is particularly preferred that the rhenium copromoter comprises, as an element, tungsten.

The rhenium copromoter may typically be present in a total quantity of at least 0.05 mmole/kg, more typically at least 0.5 mmole/kg, and preferably at least 2.5 mmole/kg, calculated as the element (i.e. the total of tungsten, chromium, molybdenum, sulfur, phosphorus and/or boron), relative to the weight of Group 11 metal. The rhenium  
5 copromoter may be present in a total quantity of at most 200 mmole/kg, preferably at most 50 mmole/kg, more preferably at most 25 mmole/kg, on the same basis. The form in which the rhenium copromoter may be deposited is not material to the invention. For example, it may suitably be provided as an oxide or as an oxyanion, for example, as a sulfate, borate or molybdate, in salt or acid form.

10 The epoxidation catalyst preferably comprises Group 11 metal, the promoter component, and a component comprising a further element. Eligible further elements may be selected from the group of nitrogen, fluorine, alkali metals, alkaline earth metals, titanium, hafnium, zirconium, vanadium, thallium, thorium, tantalum, niobium, gallium and germanium and mixtures thereof. Preferably the alkali metals are selected from  
15 lithium, potassium, rubidium and cesium. Most preferably the alkali metal is lithium, potassium and/or cesium. Preferably the alkaline earth metals are selected from calcium and barium. Typically, the further element is present in the epoxidation catalyst in a total quantity of from 0.05 to 2500 mmole/kg, more typically from 0.25 to 500 mmole/kg, calculated as the element on the weight of Group 11 metal. The further elements may be  
20 provided in any form. For example, salts of an alkali metal or an alkaline earth metal are suitable.

As used herein, the quantity of alkali metal present in the epoxidation catalyst is deemed to be the quantity insofar as it can be extracted from the epoxidation catalyst with de-ionized water at 100 °C. The extraction method involves extracting a 10-gram sample  
25 of the catalyst three times by heating it in 20 ml portions of de-ionized water for 5 minutes at 100 °C and determining in the combined extracts the relevant metals by using a known method, for example atomic absorption spectroscopy.

As used herein, the quantity of alkaline earth metal present in the epoxidation catalyst is deemed to the quantity insofar as it can be extracted from the epoxidation  
30 catalyst with 10 %w nitric acid in de-ionized water at 100 °C. The extraction method involves extracting a 10-gram sample of the catalyst by boiling it with a 100 ml portion of 10 %w nitric acid for 30 minutes (1 atm., i.e. 101.3 kPa) and determining in the combined extracts the relevant metals by using a known method, for example atomic absorption

spectroscopy. Reference is made to US-A-5801259, which is incorporated herein by reference.

5 Methods for depositing Group 11 metal, the one or more promoter components and the one or more component comprising a further element on a carrier material are known in the art and such methods may be applied in the practice of this invention. Reference may be made to US-A-5380697, US-A-5739075, EP-A-266015, and US-B-6368998, which are incorporated herein by reference. Suitably, the methods include impregnating the particulate carrier materials with a liquid mixture comprising cationic Group 11 metal-amine complex and a reducing agent.

10 The invention relates to processes for the epoxidation of an olefin comprising reacting a feed comprising the olefin and oxygen in the presence an epoxidation catalyst, as described hereinbefore, contained in one or more process microchannels of a microchannel reactor.

15 The olefin for use in the present invention may be an aromatic olefin, for example styrene, or a di-olefin, whether conjugated or not, for example 1,9-decadiene or 1,3-butadiene. A mixture of olefins may be used. Typically, the olefin is a monoolefin, for example 2-butene or isobutene. Preferably, the olefin is a mono- $\alpha$ -olefin, for example 1-butene or propylene. The most preferred olefin is ethylene.

20 The feed for the epoxidation process of this invention comprises the olefin and oxygen. As used herein, the feed to a process is understood to represent the total of reactants and other components which is fed to the section of the process microchannels in which the process in question takes place. Some of the feed components may be fed to the epoxidation process through an opening in upstream end 220 of process microchannels 210. Some of the feed components may be fed through first feed channel 260 and one or  
25 more first orifices 280. For example, an olefin rich feed component may be fed through the opening in the upstream end of the process microchannels and an oxygen rich feed component may be fed through the first feed channel and the one or more first orifices. Alternatively, the oxygen rich feed component may be fed through the opening in the upstream end of the process microchannels and the olefin rich feed component may be fed  
30 through the first feed channel and the one or more first orifices. Certain feed components may be fed through the opening in the upstream end of the process microchannels and through the first feed channel and the one or more first orifices. For example, the olefin may be fed partly through the opening in the upstream end of the process microchannels

and partly through the first feed channel and the one or more first orifices. As another example, oxygen may be fed partly through the opening in the upstream end of the process microchannels and partly through the first feed channel and the one or more first orifices.

In an embodiment, an oxygen rich feed component may be contacted within the process microchannels with an olefin rich feed component. The oxygen rich feed component is typically relatively lean in the olefin. The oxygen rich feed component may comprise oxygen typically in a quantity of at least 5 mole-%, in particular at least 10 mole-%, more in particular at least 15 mole-%, relative to the total oxygen rich feed component, and typically in a quantity of at most 100 mole-%, or at most 99.9 mole-%, or at most 99.8 mole-%, relative to the total oxygen rich feed component. The oxygen rich feed component may comprise the olefin typically in a quantity of at most 5 mole-%, in particular at most 1 mole-%, relative to the total oxygen rich feed component. Such oxygen rich feed component may normally be outside the explosion limits. The olefin rich feed component is typically relatively lean in oxygen. The olefin rich feed component may comprise the olefin typically in a quantity of at least 20 mole-%, in particular at least 25 mole-%, more in particular at least 30 mole-%, relative to the total olefin rich feed component, and typically in a quantity of at most 100 mole-%, or at most 99.99 mole-%, or at most 99.98 mole-%, relative to the total olefin rich feed component. The olefin rich feed component may comprise oxygen typically in a quantity of at most 15 mole-%, in particular at most 10 mole-%, more in particular at most 5 mole-%, relative to the total olefin rich feed component. Such olefin rich feed component may normally be outside the explosion limits.

In the case that there is a plurality of first orifices 280, one or more first orifices 280 positioned downstream of another first orifice 280, converted reactant may be substantially replenished. For example, replenishing converted oxygen may effect that the concentration of oxygen in the feed can be maintained substantially constant along the length of the epoxidation catalyst, which may favor substantially complete conversion of the olefin. Alternatively, the concentration of the olefin may be kept substantially constant by replenishing converted olefin, which may favor substantially complete conversion of oxygen.

Further, in an aspect of the invention, by feeding the olefin rich feed component and the oxygen rich feed component through different channels and mixing the feed components in the process microchannels effects, feed compositions can be accomplished

within the process microchannels, while outside the process microchannels such feed compositions could lead to an explosion.

An organic halide may be present in the feed as a reaction modifier for increasing the selectivity, suppressing the undesirable oxidation of the olefin or the olefin oxide to carbon dioxide and water, relative to the desired formation of the olefin oxide. The organic  
5 halide may be fed as a liquid or as a vapor. The organic halide may be fed separately or together with other feed components through an opening in upstream end 220 of the process microchannels 210 or through first feed channel 260 and one or more first orifices 280. An aspect of feeding the organic halide through a plurality first orifices is that there  
10 may be an increase in the level of the quantity of the organic halide along the length of the epoxidation catalyst, by which the activity and/or selectivity of the epoxidation catalyst can be manipulated in accordance with the teachings of EP-A-352850, which is incorporated herein by reference. For example, when using a rhenium containing epoxidation catalyst, the activity of the epoxidation catalyst can be enhanced along the length of the epoxidation  
15 catalyst. This could allow for better utilization of the epoxidation catalyst in regions where oxygen or the olefin is depleted relative to the regions where oxygen and the olefin are fed.

Organic halides are in particular organic bromides, and more in particular organic chlorides. Preferred organic halides are chlorohydrocarbons or bromohydrocarbons. More preferably they are selected from the group of methyl chloride, ethyl chloride, ethylene  
20 dichloride, ethylene dibromide, vinyl chloride or a mixture thereof. Most preferred are ethyl chloride and ethylene dichloride.

In addition to an organic halide, an organic or inorganic nitrogen compound may be employed as reaction modifier, but this is generally less preferred. It is considered that under the operating conditions of the epoxidation process the nitrogen containing reaction  
25 modifiers are precursors of nitrates or nitrites (cf. e.g. EP-A-3642 and US-A-4822900, which are incorporated herein by reference). Organic nitrogen compounds and inorganic nitrogen compounds may be employed. Suitable organic nitrogen compounds are nitro compounds, nitroso compounds, amines, nitrates and nitrites, for example nitromethane, 1-nitropropane or 2-nitropropane. Suitable inorganic nitrogen compounds are, for example,  
30 nitrogen oxides, hydrazine, hydroxylamine or ammonia. Suitable nitrogen oxides are of the general formula  $\text{NO}_x$  wherein x is in the range of from 1 to 2, and include for example  $\text{NO}$ ,  $\text{N}_2\text{O}_3$  and  $\text{N}_2\text{O}_4$ .

The organic halides and the organic or inorganic nitrogen compounds are generally effective as reaction modifier when used in low total concentration, for example up to 0.01 mole-%, relative to the total feed. It is preferred that the organic halide is present at a concentration of at most  $50 \times 10^{-4}$  mole-%, in particular at most  $20 \times 10^{-4}$  mole-%, more in particular at most  $15 \times 10^{-4}$  mole-%, relative to the total feed, and preferably at least  $0.2 \times 10^{-4}$  mole-%, in particular at least  $0.5 \times 10^{-4}$  mole-%, more in particular at least  $1 \times 10^{-4}$  mole-%, relative to the total feed.

In addition to the olefin, oxygen and the organic halide, the feed may additionally comprise one or more further components, for example saturated hydrocarbons, as ballast gas, inert gases and carbon dioxide. The one or more further components may be fed separately or together with other feed components through an opening in upstream end 220 of the process microchannels 210 or through first feed channel 260 and one or more first orifices 280.

The olefin concentration in the feed may be selected within a wide range. Typically, the olefin concentration in the feed will be at most 80 mole-%, relative to the total feed. Preferably, it will be in the range of from 0.5 to 70 mole-%, in particular from 1 to 60 mole-%, on the same basis.

The oxygen concentration in the feed may be selected within a wide range. Typically, the concentration of oxygen applied will be within the range of from 1 to 15 mole-%, more typically from 2 to 12 mole-% of the total feed.

The saturated hydrocarbons comprise, for example, methane and ethane. Unless stated herein otherwise, saturated hydrocarbons may be present in a quantity of up to 80 mole-%, in particular up to 75 mole-%, relative to the total feed, and frequently they are present in a quantity of at least 30 mole-%, more frequently at least 40 mole-%, on the same basis.

Carbon dioxide may be present in the feed as it is formed as a result of undesirable oxidation of the olefin and/or the olefin oxide, and it may accordingly be present in feed components present in a recycle stream. Carbon dioxide generally has an adverse effect on the catalyst activity. Advantageously, the quantity of carbon dioxide is, for example, below 2 mole-%, preferably below 1 mole-%, or in the range of from 0.2 to 1 mole-%, relative to the total feed.

The inert gases include, for example nitrogen or argon. Unless stated herein otherwise, the inert gases may be present in the feed in a concentration of from 30 to 90 mole-%, typically from 40 to 80 mole-%.

5 The epoxidation process of this invention may be air-based or oxygen-based, see "Kirk-Othmer Encyclopedia of Chemical Technology", 3<sup>rd</sup> edition, Volume 9, 1980, pp. 445-447. In the air-based process air or air enriched with oxygen is employed as the source of the oxidizing agent while in the oxygen-based processes high-purity (at least 95 mole-%) oxygen is employed as the source of the oxidizing agent. Presently most epoxidation plants are oxygen-based and this is preferred in the practice of certain  
10 embodiment of this invention. It is an advantage of other embodiments of this invention that air may be fed to the process as the source of the oxidizing agent.

The epoxidation process may be carried out using reaction temperatures selected from a wide range. Preferably the reaction temperature is in the range of from 150 to 340 °C, more preferably in the range of from 180 to 325 °C. Typically, the heat transfer  
15 liquid present in the first heat exchange channels may have a temperature which is typically 0.5 to 10 °C lower than the reaction temperature.

As disclosed herein before, during use, the epoxidation catalysts may be subject to a performance decline. In order to reduce effects of an activity decline, the reaction temperature may be increased gradually or in a plurality of steps, for example in steps of  
20 from 0.1 to 20 °C, in particular 0.2 to 10 °C, more in particular 0.5 to 5 °C. The total increase in the reaction temperature may be in the range of from 10 to 140 °C, more typically from 20 to 100 °C. The reaction temperature may be increased typically from a level in the range of from 150 to 300 °C, more typically from 200 to 280 °C, when a fresh epoxidation catalyst or rejuvenated epoxidation catalyst is used, to a level in the range of  
25 from 230 to 340 °C, more typically from 240 to 325°C, when the epoxidation catalyst has decreased in activity.

The epoxidation process is preferably carried out at a pressure, as measured at upstream 220 end of the process microchannels 210, in the range of from 1000 to 3500 kPa.

30 The olefin oxide leaving the section of the process microchannels containing the epoxidation catalyst is comprised in a reaction mixture which may further comprise unreacted olefin, unreacted oxygen, and other reaction products such as carbon dioxide. Typically, the content of olefin oxide in the reaction product is in general in the range of

from 1 to 25 mole-%, more typically from 2 to 20 mole-%, in particular from 2 to 5 mole-%.

In an embodiment, the epoxidation process comprises reacting a feed comprising the olefin and oxygen in a total quantity of at least 50 mole-%, relative to the total feed. In this  
5 embodiment, the olefin and oxygen may be present in the feed in a total quantity of at least 80 mole-%, in particular at least 90 mole-%, more in particular at least 95 mole-%, relative to the total feed, and typically up to 99.5 mole-%, in particular up to 99 mole-%, relative to the total feed. The molar ratio of olefin to oxygen may be in the range of from 3 to 100, in particular from 4 to 50, more in particular from 5 to 20. The saturated hydrocarbons and the inert gases  
10 may be substantially absent. As used herein, in this context "substantially absent" means that the quantity of saturated hydrocarbons in the feed is at most 10 mole-%, in particular at most 5 mole-%, more in particular at most 2 mole-%, relative to the total feed, and that the quantity of inert gases in the feed is at most 10 mole-%, in particular at most 5 mole-%, more in particular at most 2 mole-%, relative to the total feed. In this particular embodiment, process  
15 conditions may be applied such that the quantity of olefin oxide in the epoxidation reaction mixture is in the range of from 4 to 15 mole-%, in particular from 5 to 12 mole-%, for example from 6 to 10 mole-%. Preferably, the epoxidation reaction mixture, including the olefin oxide, is quenched, as described herein.

In an embodiment, the epoxidation process comprises applying conditions for reacting  
20 the feed such that the conversion of the olefin or the conversion of oxygen is at least 90 mole-%. The conversion of the olefin may be at least 90 mole-% and the conversion of oxygen may be at least 90 mole-%. In particular, in this embodiment, the feed may comprise the olefin and oxygen in a quantity of at most 50 mole-%, relative to the total feed, and the feed may additionally comprise saturated hydrocarbons, as ballast gas, and inert gas. Typically, process  
25 conditions are applied such that the conversion of the olefin or the conversion of oxygen is at least 95 mole-%, in particular at least 98 mole-%, more in particular at least 99 mole-%. As used herein, the conversion is the quantity of a reactant converted relative to the quantity of the reactant in the feed, expressed in mole-%. Preferably, the conversion of the olefin is at least 95 mole-%, in particular at least 98 mole-%, more in particular at least 99 mole-% and oxygen  
30 may be at least partly replenished. The presence of an excess of oxygen in the feed, relative to the olefin, assists in achieving a high conversion of the olefin. For example, the molar ratio of oxygen over the olefin in the feed may be at least 1.01, typically at least 1.05, in particular at least 1.1, more in particular at least 1.2; and for example at most 5, in particular at most 3, more



in particular at most 2. In this embodiment, a relatively high selectivity in the conversion of the olefin into the olefin oxide is achieved. A used herein, the selectivity is the quantity of olefin oxide formed, relative to the quantity of olefin converted, expressed in mole-%.

Moreover, such high conversion of the olefin enables that the process may be carried out economically in a once-through mode, which means that no recycle of unconverted reactants is applied, and that air may be fed to the epoxidation process, which means effectively that the need of an air separation unit is eliminated.

In the practice of this invention, the reaction product, including the olefin oxide, may be quenched, typically, by heat exchange with a heat exchange fluid. The quenching may be conducted in first intermediate section 440 of process microchannels 210 by heat exchange with heat exchange fluid present in one or more third heat exchange channels 450. Typically, the temperature of the reaction product, including the olefin oxide, may be decreased to a temperature of at most 250 °C, more typically at most 225 °C, preferably in the range of from 20 to 200 °C, more preferably 50 to 190 °C, in particular from 80 to 180 °C. The quenching may result in a reduction in temperature in the range of from 50 to 200 °C, in particular from 70 to 160 °C. Quenching enables increasing the total quantity of the olefin oxide and oxygen in the feed of the epoxidation process, and eliminating the ballast gas or reducing the quantity of ballast gas in the feed of the epoxidation process. Also, a result of quenching is that the olefin oxide produced is a cleaner product, comprising less aldehyde and carboxylic acid impurities.

A portion of the epoxidation reaction mixture, including the olefin oxide, may be partly withdrawn from the process microchannel and the microchannel reactor and be processed in the conventional manner, using conventional methods and conventional equipment. However, this does not represent a preferred embodiment of the inventive process. The conversion of the olefin oxide with carbon dioxide in the second section of the one or more process microchannels may be a conversion which is catalyzed by using a suitable catalyst.

Suitable catalysts for the conversion of the olefin oxide with carbon dioxide may be, for example, resins which comprise quaternary phosphonium halide groups or quaternary ammonium halide groups on a styrene/divinylbenzene copolymer matrix, wherein the halide may be in particular chloride or bromide. Such catalysts for this conversion are known from T. Nishikubo, A. Kameyama, J. Yamashita and M. Tomoi, *Journal of Polymer Science, Pt. A. Polymer Chemist*, 31, 939 - 947 (1993), which is

incorporated herein by reference. More suitable catalysts comprise a metal salt immobilized in a solid carrier, wherein the metal salt may comprise a cation of a metal selected from those in the third Period and Group 2, the fourth Period and Groups 2 and 4-12, the fifth Period and Groups 2, 4-7, 12 and 14, and the sixth Period and Groups 2 and 4-6, of the Periodic Table of the Elements, and wherein the carrier contains a quaternary ammonium, quaternary phosphonium, quaternary arsenonium, quaternary stibonium or a quaternary sulfonium cation, which cation may be separated from the backbone of the carrier by a spacer group of the general formula  $-(CH_2-O)_m-(CH_2)_n-$ , m and n being integers, with for example n being at most 10, for example 1, 2, 3 or 6, when m is 0, and n being from 1 to 8, for example 2 or 4, when m is 1. The metal salt may be selected in particular from the halides, acetates, laurates, nitrates and sulfates of one or more selected from magnesium, calcium, zinc, cobalt, nickel, manganese, copper and tin, for example zinc bromide, zinc iodide, zinc acetate, or cobalt bromide. The solid carrier for immobilizing the metal salt may be, for example silica, a silica-alumina, or a zeolite, or it may be a resin with a polystyrene/divinylbenzene copolymer backbone, or a silica-based polymeric backbone, such as in polysiloxanes, or a resin incorporating quaternized vinylpyridine monomers. Other suitable catalysts for the conversion of the olefin oxide with carbon dioxide are, for example, quaternary phosphonium halides, quaternary ammonium halides, and certain metal halides. An example is methyltributylphosphonium iodide. More suitably, the catalysts comprise an organic base neutralized with a hydrogen halide, wherein the organic base has a  $pK_a$  greater than 8 and comprises a carbon-based compound containing one or more nitrogen and/or phosphorus atoms with at least one free electron pair. The hydrogen halide may be hydrogen bromide or hydrogen iodide. Examples of such organic bases having a  $pK_a$  greater than 8 are 2-*tert*-butylimino-2-diethylamino-1,3-dimethylperhydro-1,3,2-diazaphosphorin, as such or on polystyrene, 1,1,3,3-tetramethylguanidine, and triethanolamine. In this context, the term "neutralized" means that the organic base and the hydrogen halide have reacted in amounts relative to each other such that an aqueous solution of the reaction product would be essentially neutral, i.e. having a pH between 6 and 8.

Another suitable catalyst for the conversion of the olefin oxide with carbon dioxide comprises from 10 to 90 mole-%, based on the mixture, of an organic base and from 10 to 90 mole-%, based on the mixture, of the salt of the organic base and a hydrogen halide, wherein the organic base comprises a carbon-based compound containing one or more

nitrogen and/or phosphorus atoms with at least one free electron pair, and has a  $pK_a$  high enough that it is capable of binding carbon dioxide under the reaction conditions. The hydrogen halide may be hydrogen bromide or hydrogen iodide. Examples of such organic bases having capability of binding carbon dioxide are *2-tert-butylimino-2-diethylamino-*  
5 *1,3-dimethylperhydro-1,3,2-diazaphosphorin*, as such or on polystyrene, *1,1,3,3-*  
*tetramethylguanidine*, and *triethanolamine*. An exemplary catalyst may be based upon  
*1,1,3,3-tetramethylguanidine*, hydrogen iodide and molybdenum trioxide in a mole ratio of  
about 6.6:4.71:1. When using these catalysts in the presence of water and carbon dioxide,  
the formed 1,2-carbonate may be at least partly converted in situ to the corresponding 1,2-  
10 glycol.

The catalyst, when present as a solid material under the condition of the reaction,  
may be installed in the second section of the one or more process microchannels by known  
methods and applicable methods include, for example, filling at least a portion of the  
second section to form a packed bed, or covering at least a portion of the walls of the  
15 second section with the catalyst, for example by wash coating. Some of the methods  
related to the installation of an epoxidation catalyst, as set out hereinbefore, may be  
applicable to these catalysts in an analogous manner. The use of a catalyst which is present  
as a solid material under the condition of the reaction is less preferred. In embodiments in  
which the catalyst represents itself as a liquid under the conditions of the reaction, the  
20 catalyst may be fed to the second section of the one or more process microchannels  
through the second feed channel and the one or more second orifices, suitably together  
with feed comprising water, the alcohol, carbon dioxide and/or the amine. When the  
conversion is a thermal conversion, the temperature may be in the range of from 100 to  
300 °C, in particular from 150 to 250 °C. When the conversion is a catalytic conversion,  
25 the temperature may be in the range of from 30 to 200 °C, in particular from 50 to 150 °C.  
The molar ratio of carbon dioxide to the olefin oxide may be more than 10, for example at  
most 20 or at most 30. However, it is a benefit of this invention that adequate control of  
the temperature can be achieved when the molar ratio of the total of water, the alcohol,  
carbon dioxide and the amine is kept relatively low. The molar ratio of carbon dioxide to  
30 the olefin oxide may be at most 10, in particular in the range of from 1 to 8, more in  
particular from 1.1 to 6, for example from 1.2 to 4. The feed fed to the second section of  
the process microchannels may comprise a total quantity of the olefin oxide and carbon  
dioxide of at least 60 %w, in particular at least 80 %w, more in particular at least 90 %w,

for example at least 95 %w, relative to the total weight of the said feed. The pressure may be in the range of from 500 to 3500 kPa, as measured at the second feed channel, described hereinbefore. The reaction conditions may be selected such that the conversion of the olefin oxide is at least 50 mole-%, in particular at least 80 mole-%, more in particular at least 90 mole-%, for example at least 95 mole-%.

The temperature of the epoxidation reaction mixture, including the olefin oxide, may be controlled before the olefin oxide enters the second section of the one or more process microchannels, so that the olefin oxide may adopt the desired temperature for the conversion to the the 1,2-carbonate. Thus, the one or more process microchannels may comprise additionally an intermediate section downstream from the first section and upstream from the second section, which intermediate section is adapted to control the temperature of the olefin oxide. In particular, the reactor may comprise additionally one or more fourth heat exchange microchannels adapted to exchange heat with the first intermediate section of the said process microchannels.

The conversion of the 1,2-carbonate with water or an alcohol in the third section of the one or more process microchannels may be a thermal conversion, but preferably it is a catalytic process. The temperature may be in the range of from 50 to 250 °C, in particular from 80 to 200 °C, more in particular from 100 to 180 °C. Suitable catalysts are basic inorganic compounds, such as, for example, hydroxides of alkali metals, alkaline earth metals and metals selected from Groups 3-12 of the Periodic Table of the Elements; basic refractory oxides, such as, for example, basic aluminum oxide; and basic zeolites. Suitable alkali metals are, for example, lithium, sodium and potassium. Suitable alkaline earth metals may be, for example, calcium and magnesium. Suitable metals from Groups 3-12 of the Periodic Table of the Elements are, for example, zirconium and zinc. Other suitable catalysts are those known from US-A-4283580, which is incorporated herein by reference. More suitable catalysts comprise a metalate or bicarbonate immobilized on a solid carrier having one or more electropositive sites. The metalate is a metal oxide anion wherein the metal has a positive functional oxidation state of at least +3 and it is polyvalent (i.e. the metal can have more than one valency). The polyvalent metal is preferably selected from Groups 5 and 6 of the Periodic Table, and more preferably from tungsten, vanadium, and, in particular, molybdenum. Typical examples of such metalate anions include anions conventionally characterized by the formulae  $[\text{MoO}_4]^{2-}$ ,  $[\text{VO}_3]^-$ ,  $[\text{V}_2\text{O}_7\text{H}]^{3-}$ ,  $[\text{V}_2\text{O}_7]^{4-}$ , and  $[\text{WO}_4]^{2-}$ . It is appreciated the exact formulae of these metalate anions may vary with the

process conditions at which they are used. However, these formulae are commonly accepted as representing a fair characterization of the metalate anions in question. The bicarbonate may or may not be formed in situ from hydroxyl anions or carbonate anions by reaction with water and carbon dioxide. The solid carrier having one or more  
5 electropositive sites includes inorganic carriers, for example silica, silica alumina, zeolites, and resins containing a quaternary ammonium, quaternary phosphonium, quaternary arsenonium, quaternary stibonium or a quaternary sulfonium cation, or a complexing macrocycle, for example a crown ether. The cation, or complexing macrocycle may or may not be separated from the backbone of the resin by a spacer group suitably containing  
10 alkylene group optionally containing one or more oxygen atoms between methylene moieties. The resin may have a polystyrene/divinylbenzene copolymer backbone, or a silica-based polymeric backbone, such as in polysiloxanes, or it may be a resin incorporating quaternized vinylpyridine monomers. The catalyst may comprise molybdate  $[\text{MoO}_4]^{2-}$  or bicarbonate anions absorbed, by ion exchange from sodium molybdate or  
15 sodium bicarbonate, onto a commercially available ion exchange resin, for example Amberjet 4200 (Amberjet is a trademark).

The catalyst, when present as a solid material under the condition of the reaction, may be installed in the third section of the one or more process microchannels by known methods and applicable methods include, for example, filling at least a portion of the third  
20 section to form a packed bed, or covering at least a portion of the walls of the third section with the catalyst, for example by wash coating. Some of the methods related to the installation of an epoxidation catalyst, as set out hereinbefore, may be applicable to these catalysts in an analogous manner. In embodiments in which the catalyst represents itself as a liquid under the conditions of the reaction, the catalyst may be fed to the third section of  
25 the one or more process microchannels through the third feed channel and the one or more third orifices, suitably together with the water and/or alcohol feed. The molar ratio of the total of water and the alcohol to the 1,2-carbonate may be may be less than 10, in particular in the range of from 1 to 8, in particular from 1.1 to 6, for example from 1.2 to 4. The feed fed to the third section of the process microchannels may comprise a total quantity of the  
30 1,2-carbonate, water and the alcohol of at least 60 %w, in particular at least 80 %w, more in particular at least 90 %w, for example at least 95 %w, relative to the total weight of the said feed. The pressure may be in the range of from 100 to 5000 kPa, in particular in the range of from 200 to 3000 kPa, more in particular in the range of from 500 to 2000 kPa, as

measured at the third feed channel, described hereinbefore. The reaction conditions may be selected such that the conversion of the 1,2-carbonate is at least 50 mole-%, in particular at least 80 mole-%, more in particular at least 90 mole-%, for example at least 95 mole-%. Suitable alcohols for the conversion of the 1,2-carbonate into the 1,2-diol may be

5 methanol, ethanol, propanol, isopropanol, 1-butanol and 2-butanol. Methanol is a preferred alcohol. Mixtures of alcohols and mixtures of water and one or more alcohols may be used. The conversion of 1,2-carbonate with one or more alcohols generally yields the carbonates corresponding with the one or more alcohols, in addition to a 1,2-diol. For

10 example, conversion of ethylene carbonate with methanol generally yields ethylene glycol and dimethyl carbonate. The temperature of the epoxidation reaction mixture, including the olefin oxide, may be controlled before the olefin oxide enters the second section of the one or more process microchannels, so that the olefin oxide may adopt the desired

temperature for the conversion to the 1,2-carbonate. The temperature of the carboxylation reaction mixture, including the 1,2-carbonate, may be controlled before the 1,2-carbonate

15 enters the third section of the one or more process microchannels, so that the 1,2-carbonate may adopt the desired temperature for the conversion to the 1,2-diol. Thus, the one or more process microchannels may comprise additionally a first intermediate section downstream from the first section and upstream from the second section, which first

intermediate section is adapted to control the temperature of the olefin oxide, and a second

20 intermediate section downstream from the second section and upstream from the third section, which second intermediate section is adapted to control the temperature of the 1,2-carbonate. In particular, the reactor may comprise additionally one or more fourth heat exchange channels adapted to exchange heat with the first intermediate section of the said process microchannels and one or more fifth heat exchange channels adapted to exchange

25 heat with the second intermediate section of the said process microchannels.

The 1,2-diols, for example ethylene glycol and 1,2-propylene glycol may be used in a large variety of industrial applications, for example in the fields of food, beverages, tobacco, cosmetics, thermoplastic polymers, curable resin systems, detergents, heat transfer systems, etc.

30 Unless specified otherwise, the organic compounds mentioned herein, for example the olefins, alcohols, 1,2-diols, and organic halides, have typically at most 40 carbon atoms, more typically at most 20 carbon atoms, in particular at most 10 carbon atoms, more in particular at most 6 carbon atoms. Typically, the organic compounds have at least one

carbon atom. As defined herein, ranges for numbers of carbon atoms (i.e. carbon number) include the numbers specified for the limits of the ranges.

The following example is intended to illustrate the advantages of the present invention and is not intended to unduly limit the scope of the invention.

5 Example

This prophetic example describes how an embodiment of this invention may be practiced.

10 A microchannel reactor will comprise process microchannels, first heat exchange microchannels, second heat exchange microchannels, third heat exchange microchannels, fourth heat exchange microchannels, fifth heat exchange microchannels, first feed channels, second feed channels and third feed channels. The process microchannels will comprise an upstream end, a first section, a first intermediate section, a second section, a second intermediate section, and a third section.

15 The first section will be adapted to exchange heat with a heat exchange fluid flowing in the first heat exchange microchannels. A first feed microchannel will end in the first section of the process microchannel through first orifices. The first orifices will be positioned at approximately equal distances into the downstream direction of the first section from the upstream end of the microchannel till two thirds of the length of the first section, and in the perpendicular direction the orifices will be positioned at approximately  
20 equal distances approximately across the entire width of the process microchannel. Second orifices will be positioned in a similar manner relative to the second section, and will connect the second feed microchannels with the second section of the process microchannels. Third orifices will be positioned in a similar manner relative to the third section, and will connect the third feed microchannels with the third section of the process  
25 microchannels. The second heat exchange microchannels will comprise one set of second heat exchange microchannels adapted to exchange heat with the second sections, such that in the second sections a selected temperature will be maintained. The third heat exchange microchannels will comprise one set of third heat exchange microchannels adapted to exchange heat with the third sections, such that in the third sections a selected temperature  
30 will be maintained. The fourth heat exchange microchannels will comprise two sets of fourth heat exchange microchannels adapted to exchange heat with the first intermediate section, such that in the downstream portion of the first intermediate section a lower temperature will be achieved than in the upstream portion of the first intermediate section.

The fifth heat exchange microchannels will comprise one set of fifth heat exchange microchannels adapted to exchange heat with the second intermediate sections, such that in the second intermediate sections a selected temperature will be maintained.

The first section will comprise an epoxidation catalyst comprising silver, rhenium, tungsten, cesium and lithium deposited on a particulate carrier material, in accordance with the present invention. The particulate carrier material will be an  $\alpha$ -alumina having a surface area of 1.5 m<sup>2</sup>/g, a total pore volume of 0.4 ml/g, and a pore size distribution such that that pores with diameters in the range of from 0.2 to 10  $\mu$ m represent 95 % of the total pore volume, and that pores with diameters in the range of from 0.3 to 10  $\mu$ m represent more than 92 %, of the pore volume contained in the pores with diameters in the range of from 0.2 to 10  $\mu$ m.

The microchannel reactor will be assembled in accordance with methods known from WO-A-2004/099113, and references cited therein. The carrier material will be deposited on the walls of the first section of the process microchannels by wash coating. Thereafter, the process microchannels will be assembled, and after assembly silver, rhenium, tungsten, cesium and lithium will be deposited on the carrier material by using methods, which are known per se from US-A-5380697.

As an alternative, the microchannel reactor will be assembled, without prior wash coating, and after assembly the first section will be filled with a particulate epoxidation catalyst which will be prepared by milling and sieving a commercial HS-PLUS epoxidation catalyst, which may be obtained from CRI Catalyst Company, Houston, Texas, USA.

In either alternative, the first section will be heated at 220 °C by heat exchange with the heat exchange fluid flowing in the first heat exchange microchannel, while ethylene is fed through an opening positioned at the upstream end of the process microchannels. A mixture of oxygen and ethyl chloride (3 parts by million by volume) will be fed through the feed channels. The molar ratio of oxygen to ethylene will be 1:1. The mixture exiting the first section and entering the first intermediate section of the process microchannels will be quenched in the first intermediate section in two steps, initially to a temperature of 150 °C and subsequently to a temperature of 80 °C. The temperature and the feed rate of the ethylene and oxygen will be adjusted such that the conversion of ethylene is 97 mole-%. Then, the quantity of ethyl chloride in the mixture of oxygen and ethyl chloride will be adjusted so as to optimize the selectivity to ethylene oxide.



The quenched mixture, comprising ethylene oxide, exiting the first intermediate section and entering the second section will react in the second section with carbon dioxide in the presence of a 1 %-w aqueous solution of methyltributylphosphonium iodide, to convert ethylene oxide into ethylene carbonate. The aqueous methyltributylphosphonium iodide solution and carbon dioxide will enter the second section through the second orifices. The molar ratio of carbon dioxide to ethylene oxide will be 1.5:1. The temperature in the second section is maintained at 80 °C by heat exchange with a heat exchange fluid flowing in the second heat exchange microchannel.

The reaction mixture, comprising ethylene carbonate, exiting the second section and entering the second intermediate section will be heated in the second intermediate section to 90 °C by heat exchange with a heat exchange fluid flowing in the fifth heat exchange microchannel. Subsequently, the reaction mixture comprising ethylene carbonate will react in the third section with water in the presence of a 1 %-w aqueous solution of potassium hydroxide, to convert ethylene carbonate into ethylene glycol. The aqueous potassium hydroxide solution will enter the third section through the third orifices. The molar ratio of water to ethylene carbonate will be 2:1. The temperature in the second section is maintained at 90 °C by heat exchange with a heat exchange fluid flowing in the third heat exchange microchannel.

The reaction product, including ethylene glycol, may be separated and purified.

CLAIMS

1. A process for the preparation of a 1,2-diol, which process comprises
- 5 - reacting a feed comprising an olefin and oxygen in the presence an epoxidation catalyst contained in a first section of one or more process microchannels of a microchannel reactor to form an olefin oxide,
- converting the olefin oxide with carbon dioxide to form a 1,2-carbonate in a second section of the one or more process microchannels positioned downstream of the first section, and
- 10 - converting the 1,2-carbonate with water or an alcohol to form the 1,2-diol in a third section of the one or more process microchannels positioned downstream of the second section.
2. A process as claimed in claim 1, wherein the epoxidation catalyst comprises a Group 11 metal in a quantity of from 50 to 500 g/kg, relative to the weight of the catalyst.
3. A process as claimed in claim 1 or 2, wherein the epoxidation catalyst comprises
- 15 silver deposited in a carrier material.
4. A process as claimed in claim 3, wherein the catalyst comprises, as promoter component(s), one or more elements selected from rhenium, tungsten, molybdenum, chromium, and mixtures thereof, and additionally one or more alkali metals selected from lithium, potassium, and cesium.
- 20 5. A process as claimed in claim 3 or 4, wherein the carrier material is an alumina having a surface area at least 0.3 m<sup>2</sup>/g and at most 10 m<sup>2</sup>/g, relative to the weight of the carrier and having a pore size distribution such that pores with diameters in the range of from 0.2 to 10 μm represent more than 80 % of the total pore volume.
6. A process as claimed in any of claims 1-5, wherein the feed comprises the olefin
- 25 and oxygen in a total quantity of at least 50 mole-%, relative to the total feed.
7. A process as claimed in claim 6, wherein the feed comprises the olefin and oxygen in a total quantity of from 80 to 99.5 mole-%, relative to the total feed.
8. A process as claimed in any of claims 1-7, wherein the feed comprises saturated hydrocarbons in a quantity of at most 5 mole-%, relative to the total feed, and the feed
- 30 comprises inert gases in a quantity of at most 5 mole-%, relative to the total feed.
9. A process as claimed in claim 8, wherein the quantity of saturated hydrocarbons is at most 2 mole-%, relative to the total feed, and the quantity of inert gases is at most 2 mole-%, relative to the total feed.

10. A process as claimed in any of claims 1-9, which process additionally comprises quenching the olefin oxide in a first intermediate section, which is positioned downstream of first section and upstream of second section.

11. A process as claimed in claim 10, wherein quenching comprises decreasing the  
5 temperature of the first mixture to a temperature in the range of from 20 to 200 °C.

12. A process as claimed in claim 10 or 11, wherein the process comprises quenching by heat exchange with a heat exchange fluid.

13. A process as claimed in any of claims 10-12, wherein the process comprises quenching in more than one stage by heat exchange with a plurality of heat exchange fluids  
10 having different temperatures.

14. A process as claimed in any of claims 1-13, wherein the process comprises converting the olefin oxide with carbon dioxide applying a molar ratio of carbon dioxide to the olefin oxide of at most 10.

15. A process as claimed in claim 14, wherein the molar ratio is in the range of from 1  
15 to 8.

16. A process as claimed in claim 15, wherein the molar ratio is in the range of from 1.1 to 6.

17. A process as claimed in any of claims 1-16, wherein the process comprises catalytically converting the olefin oxide with carbon dioxide at a temperature in the range of  
20 from 30 to 200 °C, and at a pressure in the range of from 500 to 3500 kPa, as measured at the second feed channel.

18. A process as claimed in claim 17, wherein the temperature is in the range of from 50 to 150 °C.

19. A process as claimed in claim 17 or 18, wherein converting the olefin oxide with  
25 carbon dioxide comprises converting the olefin oxide in the presence of a catalyst selected from

- resins which comprise quaternary phosphonium halide groups or quaternary ammonium halide groups on a styrene/divinylbenzene copolymer matrix;
- catalysts comprising a metal salt immobilized in a solid carrier, wherein the metal salt  
30 comprises a cation of a metal selected from those in the third Period and Group 2, the fourth Period and Groups 2 and 4-12, the fifth Period and Groups 2, 4-7, 12 and 14, and the sixth Period and Groups 2 and 4-6, of the Periodic Table of the Elements, and wherein the carrier contains a quaternary ammonium, quaternary phosphonium, quaternary arsenonium,

quaternary stibonium or a quaternary sulfonium cation, which cation may or may not be separated from the backbone of the carrier by a spacer group of the general formula  $-(\text{CH}_2\text{-O})_m\text{-(CH}_2)_n-$ ,  $m$  and  $n$  being integers, with  $n$  being at most 10, when  $m$  is 0, and  $n$  being from 1 to 8, when  $m$  is 1;

- 5 - quaternary phosphonium halides, quaternary ammonium halides, and metal halides;
- catalysts comprising an organic base neutralized with a hydrogen halide, wherein the organic base has a  $\text{pK}_a$  greater than 8 and comprises a carbon-based compound containing one or more nitrogen and/or phosphorus atoms with at least one free electron pair; and
- catalysts comprising from 10 to 90 mole-%, based on the mixture, of an organic base and  
10 from 10 to 90 mole-%, based on the mixture, of the salt of the organic base and a hydrogen halide, wherein the organic base comprises a carbon-based compound containing one or more nitrogen and/or phosphorus atoms with at least one free electron pair, and has a  $\text{pK}_a$  high enough that it is capable of binding carbon dioxide under the reaction conditions.

20. A process as claimed in claim 19, wherein

- 15 - the metal salt is a metal salt selected from halides, acetates, laureates, nitrates and sulfates of one or more selected from magnesium, calcium, zinc, cobalt, nickel, manganese, copper and tin, or
- the solid carrier for immobilizing the metal salt is selected from a silica-alumina, a zeolite, a resin with a polystyrene/divinylbenzene copolymer backbone, a silica-based polymeric  
20 backbone, and a resin incorporating quaternized vinylpyridine monomers; or
- the catalyst is methyltributylphosphonium iodide; or
- the organic base is selected from 2-*tert*-butylimino-2-diethylamino-1,3-dimethylperhydro-1,3,2-diazaphosphorin, as such or on polystyrene, 1,1,3,3-tetramethylguanidine, and triethanolamine.

25 21. A process as claimed in any of claims 1-20, wherein the process comprises converting the 1,2-carbonate with water or an alcohol in the presence of a catalyst which is selected from

- basic inorganic compounds;
- basic refractory oxides;
- 30 - basic zeolites; and
- metalates or bicarbonate immobilized on a solid carrier having one or more electropositive sites, wherein the metalate is a metal oxide anion of a polyvalent metal which has a positive functional oxidation state of at least +3.

22. A process as claimed in claim 21, wherein
- the basic inorganic compounds are selected from hydroxides of alkali metals, alkaline earth metals and metals selected from Groups 3-12 of the Periodic Table of the Elements; or
  - the basic refractory oxides are selected from basic aluminum oxides; or
  - 5 - the polyvalent metal is selected from Groups 5 and 6 of the Periodic Table; or
  - the solid carrier having one or more electropositive sites is selected from inorganic carriers, and from resins containing a quaternary ammonium, quaternary phosphonium, quaternary arsenonium, quaternary stibonium or a quaternary sulfonium cation, or a complexing macrocycle, wherein the cation or complexing macrocycle may be separated from the
  - 10 backbone of the resin by a spacer group containing an alkylene group optionally containing one or more oxygen atoms between methylene moieties.

23. A process as claimed in claim 22, wherein
- the alkali metals are selected from lithium, sodium and potassium; or
  - the alkaline earth metals are selected from calcium and magnesium; or
  - 15 - the metals from Groups 3-12 of the Periodic Table of the Elements are selected from zirconium and zinc; or
  - the polyvalent metal is selected from tungsten, vanadium, and molybdenum; or
  - the solid carrier having one or more electropositive sites is selected from inorganic carriers including silica, silica alumina, zeolites, and resins containing a quaternary ammonium,
  - 20 quaternary phosphonium, quaternary arsenonium, quaternary stibonium or a quaternary sulfonium cation, or a complexing macrocycle being a crown ether, wherein the resins have a polystyrene/divinylbenzene copolymer backbone, or a silica-based polymeric backbone, or incorporate quaternized vinylpyridine monomers.

24. A process as claimed in any of claims 1-23, wherein the process comprises
- 25 converting the 1,2-carbonate with water or an alcohol at a molar ratio of the total of water and the alcohol to the olefin oxide of at most 10.

25. A process as claimed in claim 24, wherein the molar is in the range of from 1 to 8.

26. A process as claimed in claim 25, wherein the molar is in the range of from 1.1 to

6.

27. A process as claimed in any of claims 1-26, wherein the process comprises
- 30 catalytically converting the olefin oxide with carbon dioxide at a temperature in the range of from 50 to 250 °C, and at a pressure in the range of from 200 to 3000 kPa, as measured at the second feed channel.

28. A process as claimed in claim 27, wherein the temperature is in the range of from 80 to 200 °C, and at a pressure in the range of from 500 to 2000 kPa, as measured at the second feed channel.

29. A process as claimed in any of claims 1-28, wherein the alcohol is selected from methanol, ethanol, propanol, isopropanol, 1-butanol and 2-butanol.

30. A process for the preparation of a 1,2-diol, which process comprises converting in one or more process microchannels of a microchannel reactor a 1,2-carbonate with water or an alcohol to form the 1,2-diol.

31. A reactor suitable for the preparation of a 1,2-diol, which reactor is a microchannel reactor comprising  
one or more process microchannels comprising

- an upstream end,
- a downstream end,
- a first section which is adapted to contain an epoxidation catalyst, to receive a feed comprising an olefin and oxygen, and to cause conversion of at least a portion of the feed to form an olefin oxide in the presence of the epoxidation catalyst,
- a second section positioned downstream of the first section which is adapted to receive the olefin oxide, to receive carbon dioxide, and to cause conversion of the olefin oxide to form a 1,2-carbonate, and
- a third section positioned downstream of the first section which is adapted to receive the 1,2-carbonate, to receive water or an alcohol, and to cause conversion of the 1,2-carbonate to form a 1,2-diol.

32. A reactor as claimed in claim 31, which reactor comprises additionally one or more first heat exchange channels adapted to exchange heat with the first section of the said process microchannels,  
one or more second heat exchange channels adapted to exchange heat with the second section of the said process microchannels, and  
one or more third heat exchange channels adapted to exchange heat with the third section of the said process microchannels.

33. A reactor as claimed in claim 31 or 32, which reactor comprises additionally a first intermediate section downstream from the first section and upstream from the second section, which first intermediate section is adapted to control the temperature of the olefin oxide, and

a second intermediate section downstream from the second section and upstream from the third section, which second intermediate section is adapted to control the temperature of the 1,2-carbonate.

34. A reactor as claimed in claim 33, which reactor comprises additionally  
5 one or more fourth heat exchange channels adapted to exchange heat with the first intermediate section of the said process microchannels, and  
one or more fifth heat exchange channels adapted to exchange heat with the second  
intermediate section of the said process microchannels.

35. A reactor as claimed in any of claims 31-34, wherein the second section and the  
10 third section are additionally adapted to contain a catalyst.

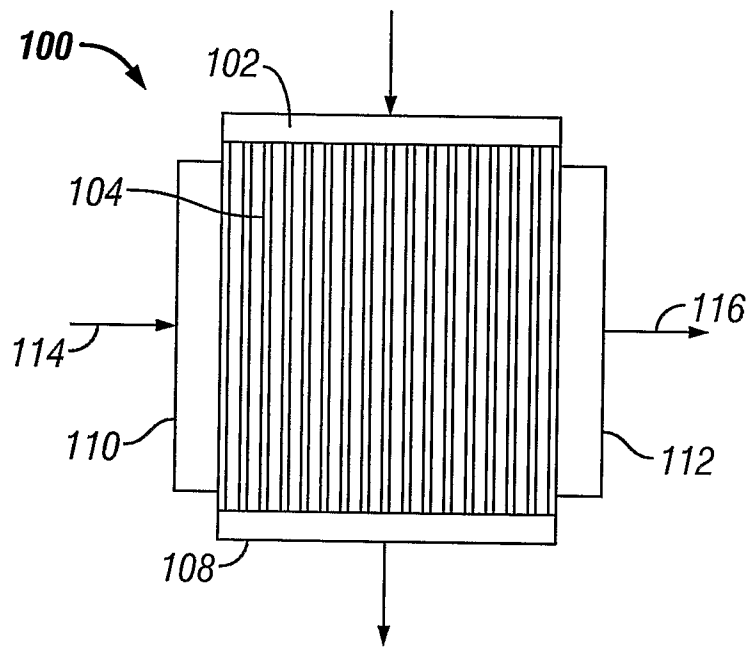

**FIG. 1**



