

Dec. 11, 1934.

H. J. ZETZMANN

1,984,105

KEYING

Filed Aug. 24, 1933

2 Sheets-Sheet 1

Fig. 2

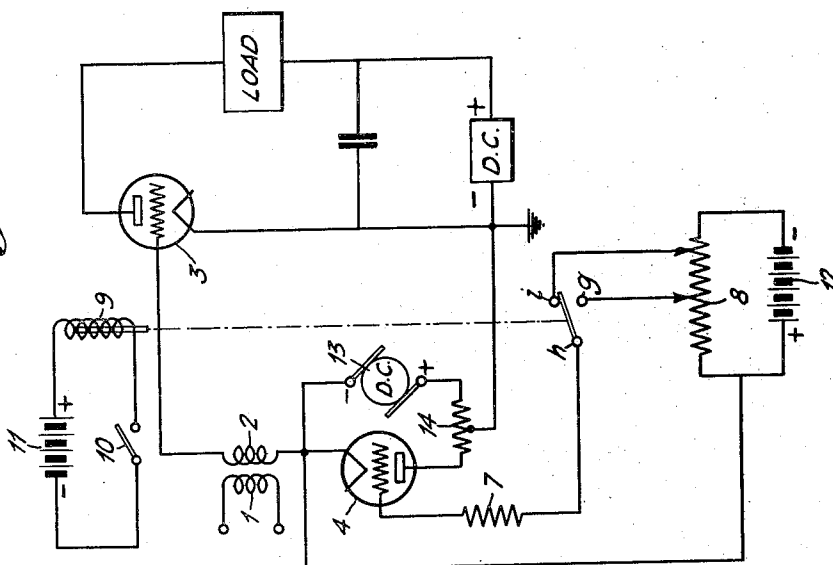
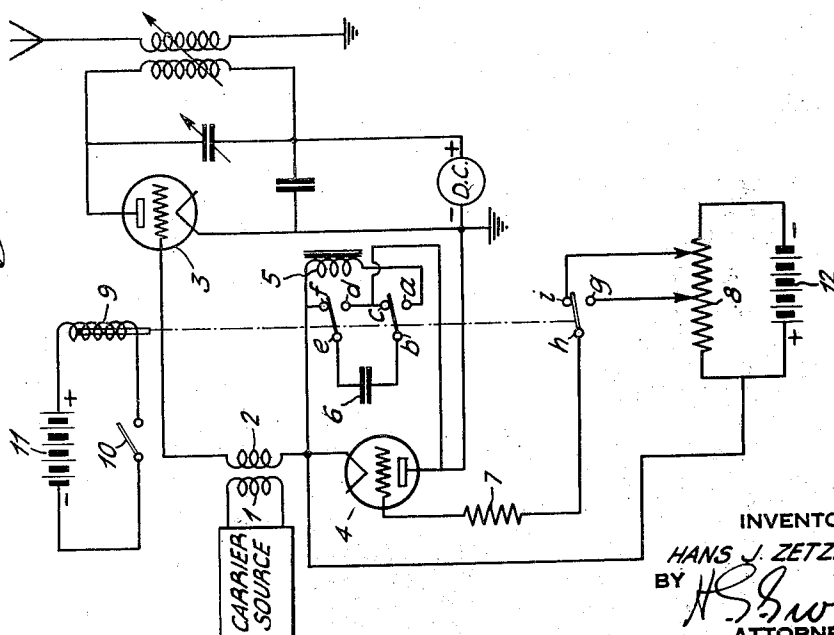

Fig. 1



INVENTOR
HANS J. ZETZMANN
BY *H. Shover*
ATTORNEY

Dec. 11, 1934.

H. J. ZETZMANN

1,984,105

KEYING

Filed Aug. 24, 1933

2 Sheets-Sheet 2

Fig. 3

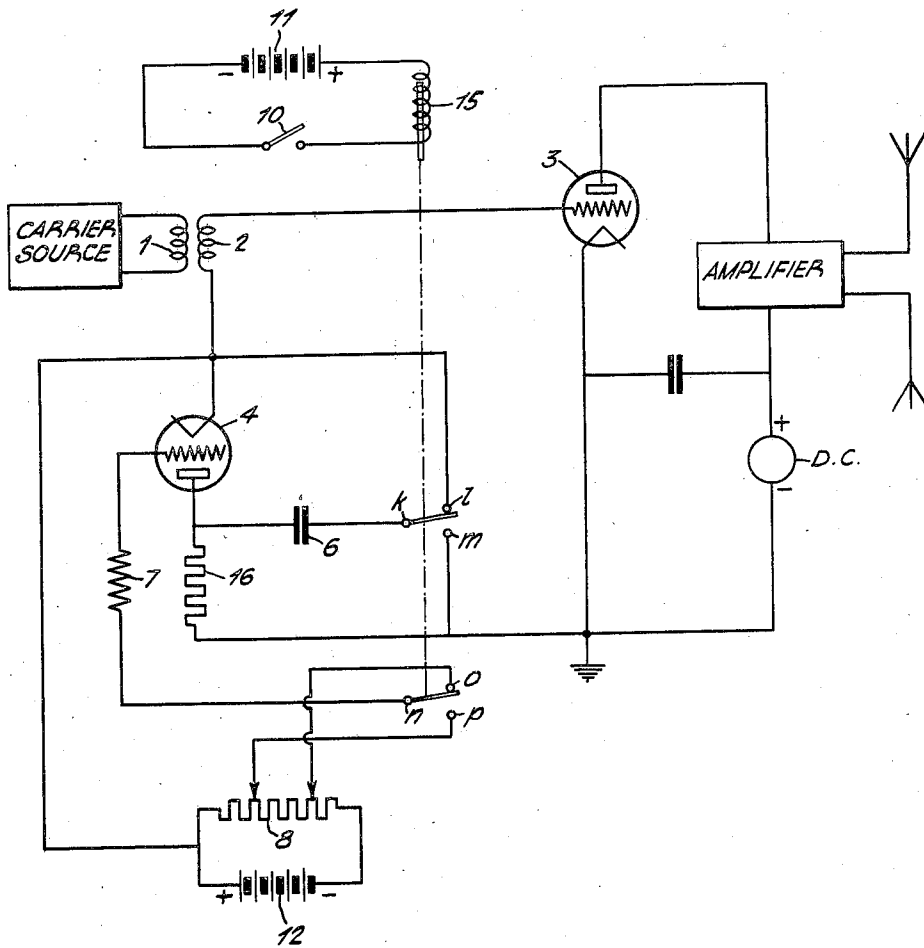

INVENTOR
HANS J. ZETZMANN
BY *H.S. Sover*
ATTORNEY

UNITED STATES PATENT OFFICE

1,984,105

KEYING

Hans Joachim Zetzmann, Berlin, Germany, assignor to Telefunken Gesellschaft für Drahtlose Telegraphie m. b. H., Berlin, Germany, a corporation of Germany

Application August 24, 1933, Serial No. 686,580
In Germany July 7, 1932

5 Claims. (Cl. 250—17)

The present invention relates to a circuit arrangement for tube-type transmitters adapted to insure keying free from clicks and chirps.

In the keying of tube-type transmitters the "rounding-off" and building up of the keyed signals, as is well known, plays an important part in practice for the reason that a signal that is not rounded off contains a great many overtones or harmonics of the keying frequency. The consequence is that the transmitter covers too wide a frequency band.

A great number of suggestions have been made in the prior art designed to result in useful rounding off of the signals. However, in many instances rounding off of the signals is of less importance than the provisions of means for preventing the clicking of the relays. The latter results in very unfavorable wave-fronts in the keyed signals.

For purposes of illustration we shall examine a two-stage telegraphic transmitter of relatively large power, say 20 kw or over, of the kind built about 10 years ago and quite frequently found in actual use today.

Inasmuch as keying of the control or exciter stage of the transmitter is out of the question on account of the troublesome building-up of transients, due to frequency modulation associated therewith, the keying is preferably done in the grid circuit of one of the main stages. However, in order to insure a useful form of signal, attention must be paid not only to the rounding-off in the building-up or incipient phenomena in the master stage which is keyed, but also attention must be given to the clickless, non-rebounding, operation of the relay contacts controlling the grid current of the master stage keyed.

In the case of a transmitter of the above-mentioned capacity, the grid current to be modulated amounts to about $\frac{3}{4}$ amperes. In direct keying, therefore, larger relays with larger rocking masses must be employed in order to satisfactorily handle the said currents over an extended period of operation. However, even in spite of ample spark-quenching or blow-out means, marked wear and tear of the contacts by thermal action and the consequent irregularities resulting therefrom must be contended with. All of these difficulties grow with the keying frequency so that where multiple or Siemens-Verdan equipment is dealt with, they assume considerable proportions. The suggestion has, therefore, been made to effect the key-

ing by way of auxiliary input tubes. These tubes may then be controlled by the agency of smaller relays almost without any expenditure of energy. But this involves a considerable tube layout, in fact, in the above-mentioned instance where the grid current is 0.75 amperes, at least four small tubes of the type RS 18 are required.

The present invention obviates these difficulties at one stroke, as it were, in that an ionic control tube is employed as the modulator tube. The control tube may be of the hot cathode type and be such that the current passes through the tube as an arc whose starting may be controlled by the grid. After starting the flow cannot be influenced by changes in the grid potential, but can be stopped by removing or decreasing the anode voltage. The operation of the tube therefore consists in removing the anode potential to stop the discharge, and controlling its restarting by the applying of the proper grid potential. (See General Electric Review for July 1929.) Such a tube is known as a "Thyratron". In the present example, such a control tube would not be much larger than general receiver tubes; hence, contrasted with the above-mentioned four RS 18 model tubes, it represents but little outlay and equipment, while by virtue of its electrical properties it is in a position to prevent relay clicks from entering into and affecting the radiated key signals.

The operation in practice of the idea underlying the invention and the advantages realizable thereby compared with the earlier art shall be explained in more detail in what follows by reference to the drawings in which Figures 1, 2 and 3 illustrate a number of fundamental key diagrams arranged in accordance with the present invention.

In Figure 1, 3 denotes the tube of the master or final stage of a telegraphic transmitter to be key-modulated. The controlling alternating voltage at carrier frequency is fed to tube 3 by way of the coupling transformer 1, 2 from the source as shown. 4 denotes the ionic control tube connected to act as a modulator tube, the said tube having an atmosphere of a rare gas or mercury vapor. The grid circuit of the tube 4 includes a current-limiting resistance 7. The switch contacts *e, f, d* and *b, c, a*, connect a condenser 6 in parallel with the anode to cathode impedance of the tube 4. The polarity of the condenser 6 depends on the position of *e* and *b*. 9 is the modulator or keying relay which in-

cludes contacts *a, c, d, f, i* and *g*. The relay 9 is energized from the battery 11 by way of the key 10. 8 is a potentiometer arrangement fed from the battery 12 from which two different potentials may be applied to the grid of the ionic control tube 4.

In the light of the well known characteristics of the ionic control tube, as given above, in unkeyed condition, as well known, a sufficiently high negative grid biasing voltage applied to the control grid of the tube 4 by way of relay contact *h* bearing on *i*, will completely block all flow of current through the tube 4 and thus block the grid current of the master transmitter tube 3. This is true even though the anode of 4 is positive relative to the cathode of 4 due to the fact that the grid of 3 obtains a number of electrons from the cathode of 3, and the grid of 3 is therefore negatively charged with respect to the cathode. Moreover this charge cannot be dissipated through the impedance of 4 since during the intermissions the thyatron 4 is non-conductive. Since the anode of the thyatron is connected to the cathode of the tube 3 and the cathode of the thyatron is connected to the grid of 3, the anode of the thyatron has a positive potential with respect to the cathode of the thyatron. If, then, the key 10 be depressed and the relay coil 9 traversed by current, the relay contact *h* will be shifted over to bear on *g*, and as a result a less negative grid bias potential is applied to the grid of the tube 4. If this voltage falls inside the range of the grid voltage flashing or lighting characteristic of the ionic tube a discharge will take place. The plate circuit of tube 4, which is common to the grid circuit of tube 3, is completed immediately. The tube 4 now permits passage of a positive current in the direction from the anode to the cathode thereof, and the negative electrons previously accumulated on the grid of tube 3 may now return to the cathode of the tube 3 through the thyatron in a direction from its cathode to its anode. In this manner the negative charge on the grid of tube 3 is reduced to such a degree that tube 3 will be conductive. If the incipient voltages or wave front of the keying signal is to be rounded off beyond the normal building-up phenomenon all that is necessary is to retard the supply of the plate current in 4 by means of a choke-coil combination.

Now, the most essential advantage residing in the use of an ionic control tube for modulation purposes is that the relay 9 may be subject to considerable rebounding. Even if the contact *h, g*, be closed only for an extremely brief period of time say less than one-thousandth of one second, the ionic control tube is caused to flash. The contact *h, g*, may then be opened one or more times by virtue of rebound as normally happens in the working of a relay contact without stopping the current flow through the tube 4. This flow stops only when the anode potential is removed.

In keyed condition, the contact *b* of relay 9 bears on *a* and the contact *e* on *d*, and the capacity 6 is charged up to the potential prevailing between the plate and cathode of the ionic control tube 4. In order to insure a stable mode of operation in keyed condition, it has been found to be suitable to provide a circuit element as indicated at 5, which consists of a resistance or a choke-coil, and which prevents the arising of free relaxation oscillations which are due to the

ohmic resistance of the grid circuit of the tube 3. The ohmic resistances are not shown in Figure 1 which is intended only as a fundamental circuit designed to show the underlying principle of the invention.

If, then, the key is opened, the relay contacts *b, e, h*, fall back upon *c, f, i*. Upon the grid of the tube 4 there is again impressed a high negative voltage. At the same time, the potential across the capacity 6 is applied to the anode of tube 4 in opposition to the natural fall of potential therethrough. The resultant voltage at the anode becomes zero for a short instant, or at any rate so low that it will no longer be adequate for maintaining ionization in the tube, with the result that the latter goes out and becomes less conductive. The tube 4 offers high impedance to the flow of current in the grid of tube 3 and 3 is less conductive.

Figure 2 shows what way one will have to proceed if, in blocked state, an additional negative grid biasing voltage is to be imparted to the grid of the master tube 3. In blocked state, the full potential of the source 13 is active on the grid of tube 3 whereas in keyed condition there will be active only the fall of potential occasioned across the anode to cathode impedance of tube 4 and the part of the resistance 14 situated between the plate of tube 4 and the point on the resistance 14.

Figure 3 illustrates an embodiment of somewhat different design where a supplemental resistance 16 is included in the grid circuit of the master tube 3. The fall of potential set up across the terminals of resistance 16 charges the capacity 6 up to a voltage at which, when the key is caused to shift over from *m* to *l* upon opening the key 10 the voltage at the tube 4 is compensated. Many other modifications may be made and the circuit schemes hereinbefore described are intended merely to explain the fundamentals of the operation. In order to secure precise operation of the circuit arrangements here disclosed, it has turned out to be suitable that the Morse contact by which the grid biasing voltages are fed to the tube 4 should be so adjusted that its contact path or distance is smaller than the contact path of the contacts used for potential compensation, with the result that the former will be closed invariably at an earlier instant than the latter.

By the use of an ionic control tube for modulation, therefore, it is feasible to insure the keying of a large power transmitter with little auxiliary tube means, and at the same time to render conditions free from irregularities and imperfections in the mechanical keying or modulation devices consisting of rebound and the like actions.

I claim:

1. The combination of a thermionic repeater tube having input electrodes energized at carrier frequency and output electrodes coupled to a load circuit, of an ionic control tube of the type in which discharge is initiated by a predetermined grid voltage and continues irrespective of the value of said grid voltage until the anode potential reaches a certain value, a connection between the cathode of said discharge tube and the control grid of said repeater, a connection between the anode of said ionic control tube and the cathode of said repeater tube, a source of potential, keying means for applying different values of negative potential from said

source to the grid of said ionic discharge tube in different positions of said key, a capacity, a second key actuated simultaneously with said first key, and circuits cooperating with said second key to connect the capacity between the anode and cathode of said ionic discharge tube in one position of said keys, and to reverse the connection of said capacity in another position of said keys.

2. The combination of a thermionic repeater tube having input electrodes energized at carrier frequency and output electrodes coupled to a load circuit, of an ionic control tube of the type in which discharge is initiated by a predetermined grid voltage and continues irrespective of the value of said grid voltage until the anode potential reaches a certain value, a connection between the cathode of said discharge tube and the control grid of said repeater, a connection between the anode of said ionic control tube and the cathode of said repeater tube, a source of potential, keying means for applying different values of negative potential from said source to the grid of said ionic discharge tube in different positions of said key, and a source of potential connected with the anode of said ionic discharge tube.

3. The combination of a thermionic repeater tube having input electrodes energized at carrier frequency and output electrodes coupled to a load circuit, of an ionic control tube of the type in which discharge is initiated by a predetermined grid voltage and continues irrespective of the value of said grid voltage until the anode potential reaches a certain value, a connection between the cathode of said discharge tube and the control grid of said repeater, a resistance connected between the anode of said ionic control tube and the cathode of said repeater tube, a source of potential, keying means for applying different values of negative potential from said source to the grid of said ionic discharge tube in different positions of said key, a capacity, a second key connected with said first key, and circuits cooperating with said second key to connect said capacity between the anode and cathode of said ionic discharge tube in one

position of said first named key, and in shunt to said resistance in another position of said first named key.

4. The combination of a thermionic repeater tube having input electrodes energized at carrier frequency and output electrodes coupled to a load circuit, of an ionic control tube of the type in which discharge is initiated by a predetermined grid voltage and continues irrespective of the value of said grid voltage until the anode potential reaches a certain value, a connection between the cathode of said ionic control tube and the control grid of said repeater, a resistance connected between the anode of said ionic control tube and the cathode of said repeater tube, a source of potential, keying means for applying different values of negative potential from said source to the grid of said ionic discharge tube in different positions of said key, and a source of potential connected between the anode and cathode of said ionic discharge tube.

5. The combination of a thermionic repeater tube having input electrodes energized at carrier frequency and output electrodes coupled to a load circuit of an ionic control tube of the type in which discharge is initiated by predetermined grid voltage and continues irrespective of the value of said grid voltage until the anode potential reaches a certain value, a connection between the cathode of said ionic control tube and the control grid of said repeater, a connection between the anode of said ionic control tube and the cathode of said repeater tube, a source of potential, keying means for applying different values of potential from said source to the grid of said ionic control tube in different positions of said key to control the impedance between the grid and cathode of said repeater tube, and means connected between the anode and cathode of said ionic control tube to further regulate the impedance between the cathode and control grid of said repeater tube.

HANS JOACHIM ZETZMANN.

45