

(19) World Intellectual Property
Organization
International Bureau



(43) International Publication Date
21 May 2004 (21.05.2004)

PCT

(10) International Publication Number
WO 2004/041670 A1

(51) International Patent Classification⁷: **B65D 43/16**,
83/14

(21) International Application Number:
PCT/EP2003/012435

(22) International Filing Date:
5 November 2003 (05.11.2003)

(25) Filing Language: English

(26) Publication Language: English

(30) Priority Data:
0226021.4 7 November 2002 (07.11.2002) GB

(71) Applicant (for all designated States except US): **GLAXO
GROUP LIMITED** [GB/GB]; Glaxo Wellcome House,
Berkeley Avenue, Greenford, Middlesex UB6 0NN (GB).

(72) Inventors; and

(75) Inventors/Applicants (for US only): **DAVIES, Michael,
Birsha** [GB/GB]; GlaxoSmithKline, Park Road, Ware,

Hertfordshire SG12 0DP (GB). **GODFREY, James,
William** [GB/GB]; GlaxoSmithKline, Park Road, Ware,
Hertfordshire SG12 0DP (GB). **HARVEY, Stephen,
James** [GB/GB]; GlaxoSmithKline, Park Road, Ware,
Hertfordshire SG12 0DP (GB). **RAND, Paul, Kenneth**
[GB/GB]; GlaxoSmithKline, Park Road, Ware, Hertford-
shire SG12 0DP (GB).

(74) Agent: **RICE, Jason, Neale**; GlaxoSmithKline, Corpo-
rate Intellectual Property (CN925.1), 980 Great West Road,
Brentford, Middlesex TW8 9GS (GB).

(81) Designated States (*national*): AE, AG, AL, AM, AT, AU,
AZ, BA, BB, BG, BR, BY, BZ, CA, CH, CN, CO, CR, CU,
CZ, DE, DK, DM, DZ, EC, EE, EG, ES, FI, GB, GD, GE,
GH, GM, HR, HU, ID, IL, IN, IS, JP, KE, KG, KP, KR,
KZ, LC, LK, LR, LS, LT, LU, LV, MA, MD, MG, MK,
MN, MW, MX, MZ, NI, NO, NZ, OM, PG, PH, PL, PT,
RO, RU, SC, SD, SE, SG, SK, SL, SY, TJ, TM, TN, TR,
TT, TZ, UA, UG, US, UZ, VC, VN, YU, ZA, ZM, ZW.

[Continued on next page]

(54) Title: A CONTAINER

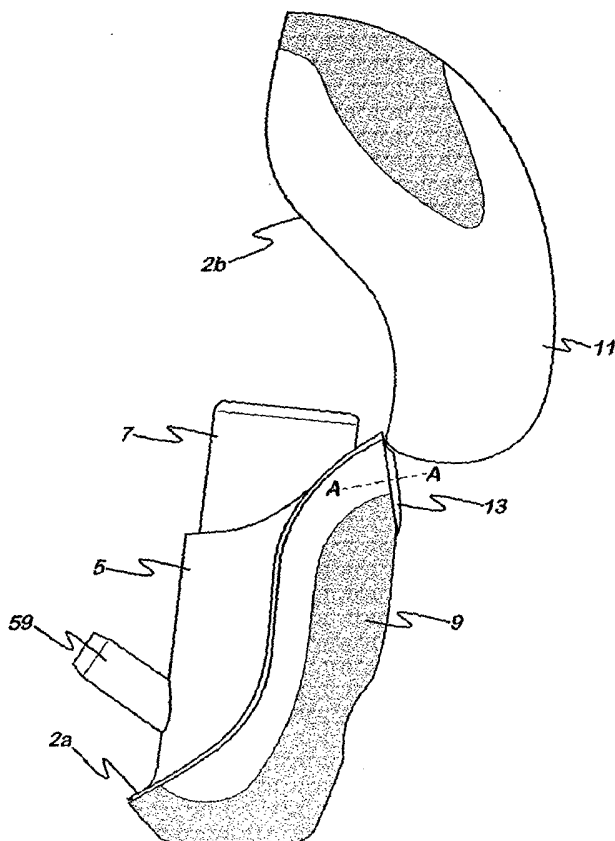

(57) Abstract: A container (3) has a first part (11), a sec-
ond part (9) and a hinge (13) through which the first and
second parts are hingeably connected so that the parts are
hingeable relative to one another between a first position
which places the container in a closed state and a second
position which places the container in an open state. The
first and second parts are also pivotally connected (A-A)
so that the parts are able to be pivoted relative to one an-
other to different angular positions.

WO 2004/041670 A1



(84) **Designated States (regional):** ARIPO patent (GH, GM, KE, LS, MW, MZ, SD, SL, SZ, TZ, UG, ZM, ZW), Eurasian patent (AM, AZ, BY, KG, KZ, MD, RU, TJ, TM), European patent (AT, BE, BG, CH, CY, CZ, DE, DK, EE, ES, FI, FR, GB, GR, HU, IE, IT, LU, MC, NL, PT, RO, SE, SI, SK, TR), OAPI patent (BF, BJ, CF, CG, CI, CM, GA, GN, GQ, GW, ML, MR, NE, SN, TD, TG).

— *before the expiration of the time limit for amending the claims and to be republished in the event of receipt of amendments*

For two-letter codes and other abbreviations, refer to the "Guidance Notes on Codes and Abbreviations" appearing at the beginning of each regular issue of the PCT Gazette.

Published:

— *with international search report*

A Container

Related Applications

5 This International patent application claims priority from UK patent application No. 0226021.4 dated 7 November 2002 and is related to the Applicant's concurrently filed International patent applications which respectively claim priority from UK patent application No. 0226022.2 dated 7 November 2002 (Applicant's Ref: P33144) and UK patent application No. 0226020.6 dated 7
10 November 2002 (Applicant's Ref: P33145). The entire content of each of these applications is hereby incorporated herein by reference.

Field of the Invention

15 The present invention relates to a container, and is particularly, but not exclusively, concerned with a container for use in a medicament dispensing system.

Background of the Invention

20 There is previously known an aerosol nasal inhalation (intranasal) device in which an aerosol canister containing a drug formulated in a pressurised fluid propellant is mounted in an outer protective container. Such a nasal inhaler is marketed under the trade name Beconase® (GlaxoSmithKline) with the drug
25 being beclomethasone dipropionate.

 The canister has a canister body holding the drug formulation which is capped with a valve assembly comprising a valve stem through which the drug formulation is selectively discharged from the canister body. The valve stem is
30 biased to an extended (closed) position relative to the canister body by a spring or the like in the valve assembly. In the extended position the valve stem places the drug formulation in fluid communication with a metering chamber in the valve assembly. This is the metering state and the metering chamber is sealed from

the external environment in this state. The valve stem is movable against the biasing force to a retracted (open) position relative to the canister body. In the retracted position the valve stem places the metering chamber in fluid communication with the external environment whereby the metered quantity of the drug formulation in the metering chamber is exhausted from the canister for administration to the patient. This is the discharge state and in this state the metering chamber is sealed from the interior of the canister body.

The container has a tube-like container part with a cavity which receives the canister therein. As known in the art, a base of the cavity presents a hollow stem block to receive the valve stem in stationary relation thereto. A nozzle sized to be received in a patient's nostril extends outwardly from the outer surface of the container part. The stem block has an orifice which is oriented towards the nozzle.

In use, the patient depresses the canister into the cavity of the container part thereby resulting in the canister body moving relative to the valve stem to bring the valve stem to its retracted position. This causes a metered amount of the drug formulation to be discharged from the valve stem and directed out of the nozzle by the stem block to be delivered in the patient's nostril.

In addition to the container part, the container has a closure part which is hinged to the mouth area of the cavity of the container part so as to be hingeable from a closed position, in which the closure part co-operates with the container part to enclose the canister and the nozzle, to an open position in which the closure and container parts are arranged "back-to-back" to expose the canister and nozzle. In the closed position the container acts as a protective casing for the inhalation device, while in the open position the patient can use the container as an applicator or holder for gripping the inhalation device when administering the drug.

It is an aim of the present invention to provide a new multi-part container, e.g. for a medicament dispensing system.

Summary of the Invention

According to the present invention there is provided a container having a
5 first part, a second part and a hinge through which the first and second parts are
hingeably connected so that the parts are hingeable relative to one another
between a first position which places the container in a closed state and a
second position which places the container in an open state, and the first and
second parts are pivotally connected so that the parts are able to be pivoted
10 relative to one another to different angular positions. The first and second parts
may be container and lid parts, respectively, perhaps of shell-like form, such as in
the embodiment hereinafter to be described. Preferably, the parts are formed
from a plastics material, preferably by moulding, for example injection moulding.

15 In an embodiment of the invention, such as hereinafter described, the
container is adapted such that the first and second parts are not pivotal relative to
one another when the container is in the closed state. To this end, in the closed
state the first and second parts may interengage one another so as to prevent
pivotal movement therebetween. The interengagement may be between
20 respective lip structures of the first and second parts.

Preferably, the hinge is a living hinge, especially when the container is
formed from a plastics material, e.g. by moulding, although other types of hinge
may be used.

25 In an embodiment of the invention, such as hereinafter described, the first
and second parts have locking elements which interengage in the closed state of
the container to lock the container in the closed state. The locking elements may
be such as to form a snap fit connection of the first and second parts in the
30 closed state of the container.

In an embodiment of the invention, such as hereinafter described, the hinge is pivotally mounted to the second part for enabling the relative pivotal movement of the first and second parts.

5 In an embodiment of the invention, such as hereinafter described, the hinge is statically mounted to the first part.

In an embodiment of the invention, such as hereinafter described, the hinge forms an integral part of the first part and is pivotally mounted to the
10 second part. In other words, the first part is pivotally mounted to the second part through the hinge. The first part may be releasably pivotally mounted to the second part, as, for example, in the embodiment hereinafter described.

In an embodiment of the invention, such as hereinafter described, the first
15 part is pivotal to a first angular position disposed behind the second part. The first part may only be pivotal to the first angular position after the container is in the open state.

Preferably, the first and second parts are adapted to nest together in a
20 nesting state when the first part is in the first angular position. The first part may be of hollow form into which the second part is receivable, at least in part, to form the nesting state. The second part may be hollow too, whereby in the closed state the respective hollows co-operate to form a product-receiving chamber enclosed by the first and second parts.

25

In an embodiment of the invention, such as hereinafter described, the second part has a rear surface in which is provided a reading feature, for example a window, the first part covers the reading feature in the first angular position and has a viewing feature to enable the reading feature to be viewed
30 through the first part when in the first angular position. As an example, the first part is at least in part made from a material sufficiently transparent to enable the reading feature to be viewed therethrough when the first part is in the first angular position.

The container may further have a detent mechanism for detenting the first and second parts in different angular positions, for example an indexing mechanism based on interengagable male and female parts, such as a ball-and-socket indexing mechanism. In this way, the detent mechanism may be adapted to detent the first part in an angular position behind the second part which provides an unimpeded view of the reading feature on the second part.

Preferably, the first and second parts form an enclosing structure when in the closed state. The enclosing structure may be an outer structure with the container including an inner part releasably, fixably securable in one of the first and second parts so as to be enclosed by the outer structure.

In an embodiment of the invention, such as hereinafter described, the inner part is adapted to be snap-fitted in one of the first and second parts, conveniently in the second part.

The inner part may be adapted to hold a product in the container with the product also enclosed by the outer structure. The product may be a package with contents to be dispensed. In this case, the inner part may be a dispenser with a dispensing mechanism for dispensing the contents of the package.

In an embodiment of the invention, such as hereinafter described, the dispensing mechanism operates through relative movement between the dispenser and the package when the dispenser is fixedly secured in the outer structure.

In an embodiment of the invention, such as hereinafter described, the dispenser has a delivery nozzle through which the contents of the package are dischargeable.

In an embodiment of the invention, such as hereinafter described, the dispenser is an intranasal dispenser.

The package and dispenser may form a dispenser assembly with the package containing multiple doses of the contents and the dispenser assembly having a dose counter for counting the number of doses dispensed from the package, the dose counter being aligned with the reading feature when the
5 dispenser assembly is secured in the container. The dose counter may be united with the package, as in the embodiment hereinafter described.

The package may be an aerosol canister with fluidic contents and having a
10 valve openable by the dispensing mechanism on relative movement of the canister to the dispenser for release of a dose of the fluidic contents from the dispenser. As an example, the valve may have a stem through which the fluidic contents is dispensed from the dispenser on relative movement thereof to the canister and the dispenser has a stand adapted to receive the stem in static
15 relation thereto whereby the canister is able to be moved relative to the stem (and the dispenser) when the stem is received in the stand for dispensing of the fluidic contents.

The contents of the package may be a pharmaceutical composition, for
20 example a pharmaceutical composition for the treatment or prophylaxis of a respiratory disease or disorder, for instance rhinitis.

According to the present invention there is also provided a medicament
dispensing system having the container of the invention.
25

Non-limiting exemplary embodiments of the invention will now be described with reference to the accompanying FIGURES of drawings.

Brief Description of the Drawings of the Exemplary Embodiments

30

FIGURE 1 is a schematic view of a patient using an intranasal device having an outer casing part in accordance with the invention.

FIGURE 2 is a side view of the intranasal device showing the outer casing part which comprises cover and container members and a hinge therebetween, the outer casing part in a closed state to protect inner parts of the device.

5 FIGURE 3 is a side view of the intranasal device with the outer casing part hinged to an open state to allow access to the inner parts.

FIGURE 4A is a side view of the intranasal device in its open state with the cover member pivoted behind the container member

10

FIGURE 4B corresponds to FIGURE 4A, but with the container and cover members nested.

15 FIGURE 5 is a rear view of the device with the outer casing part in its closed state.

FIGURE 6 is an exploded perspective view of the intranasal device with the outer casing part in its nested state.

20 FIGURE 7 is a schematic, partial sectional side view of an inner actuating part of the intranasal device mounted in the outer casing part .

FIGURE 8 is a enlarged fragmentary view of an alternative hinge construction for the outer casing part.

25

FIGURE 9 is a cross-sectional side view of the alternative hinge construction along line IX-IX in FIGURE 8.

30 FIGURE 10A is a perspective view of a canister unit of the intranasal device comprising a canister and a dose counter head mounted on the canister.

FIGURE 10B is a plan view of the dose counter head.

FIGURE 10C is a side view of the dose counter head.

FIGURE 10D is a rear view of the dose counter head.

5 FIGURE 11 is schematic side view, partly in section, of the inner actuating part of the intranasal device.

FIGURE 12 is an opposite side view of the inner actuating part with the canister unit shown mounted therein in ghost.

10

FIGURE 13 is a plan view of the inner actuating part.

FIGURE 14 is a rear view of the inner actuating part with the canister unit mounted therein.

15

FIGURE 15A is a schematic side view, partly in cross section, of the canister unit mounted in the inner actuating part in an inoperative position.

20 FIGURE 15B corresponds to FIGURE 15A, but with the canister unit in an operative position relative to the inner actuating part.

Detailed Description of the Exemplary Embodiment

25 In the FIGURES of drawings there is shown a drug delivery device 1 in accordance with the present invention, the device 1 in this particular non-limiting embodiment being an intranasal drug delivery device, as shown graphically in FIGURE 1.

30 As best shown in FIGURE 6, the intranasal drug delivery device 1 comprises as component parts the following:-

- an outer casing part 3;

- a one-piece inner actuating part 5 which is releasably securable in the outer casing part 3; and
- a canister unit 7 releasably securable in the inner actuating part 5.

5

Outer Casing Part

Referring to FIGURES 2 to 7, the outer casing part 3 of the intranasal device 1 is formed from two shell-like members, namely a container member 9 and a cover member 11, which are connected to one another through a hinge 13. The container and cover members 9, 11 each respectively present a cavity 17a; 17b having a mouth bound by a lip surface 2a; 2b (FIGURE 6).

Both the container member 9 and the cover member 11 are formed from a plastics material by injection moulding, although other types of moulding processes can, of course, be used. The container and cover members 9, 11 are preferably both formed from polypropylene with the container member 11 being opaque, but with the cover member 11 being transparent or semi-transparent. Other plastics material combinations are possible, although it is preferable for the cover member 11 to be transparent/semi-transparent for reasons which will become apparent hereinafter.

As shown in FIGURE 7, for example, the cover member 11 is integrally formed with the hinge 13, colloquially known as a "living hinge", and the hinge 13 includes a knob 15.

Turning to FIGURES 6 and 7, on an inner surface 19 of the cavity 17a of the shell-like container member 9 there is formed a pair of protrusions or ribs 21a, 21b to co-operate with complementary surfaces of the inner actuating part 5 to form a snap-fit connection between the outer casing part 3 and the inner actuating part 5, as will also be discussed in more detail hereinafter. A first one of the ribs 21a is disposed towards an upper end 23 of the container member 9,

whereas the other rib 21b is disposed towards a lower end 25 of the container member 9.

Also formed on the inner surface 19 of the cavity 17a of the container member 9 are longitudinally extending ribs 27a, 27b. The longitudinal ribs 27a, 27b are disposed on opposing sides of the container member 9 and act as anti-rotational retainers on the inner actuating part 5 in the cavity 17a.

At the upper end 23 of the container member 9 there is formed a bevel 29 through which an aperture 31 extends from an outer surface 33 of the container member 9 to the inner surface 19 of the cavity 17a. From FIGURE 7 it will be seen that the aperture 31 is adapted to receive the knob 15 on the hinge 13. Although the diameter of the knob 15 is greater than the diameter of the aperture 31, the knob 15 is able to be pushed through the aperture 31 for capture therein due to the container and cover members 9, 11 being sufficiently resiliently deformable due to their shell-like nature and the materials used. Moreover, the knob 15 is able to be withdrawn from the aperture 31 upon application of a sufficient pulling force thereto for separation of the container and cover members 9, 11.

20

As shown in FIGURES 2 to 5, the mounting of the knob 15 of the hinge 13 in the aperture 31 of the container member 9 enables two degrees of movement of the cover member 11 on the container member 9 as follows:-

(1) Hinging of the cover member 11 from a closed position shown in FIGURES 2 and 5, in which the respective lip surfaces 2a, 2b of the cavities 17a, 17b of the container and cover members 9, 11 abut one another at an interface 2c to form an enclosed internal space 8 (see FIGURE 7), to an open position shown in FIGURE 3, in which the cavity 17a of the container member 9 is accessible. As will be understood from FIGURES 6 and 7, the lip surfaces 2a, 2b are each provided with detent elements 4, 6 which engage with one another in the closed position to

30

provide a releasable snap-fit fastening of the container and cover members 9, 11 in the closed position.

- 5 (2) Rotary or pivotable movement of the cover member 11 about the aperture 31 (pivot axis A-A) from a first angular position corresponding to the open position shown in FIGURE 3 to a second angular position shown in FIGURE 4A in which the cover member 11 is located behind the container member 9. The cover member 11 is not able to be pivoted about the pivot axis A-A from its closed position due to the interengagement of the lip
10 surfaces 2a, 2b.

As shown in FIGURE 4B, when the cover member 11 is in the second angular position it is able to nest with the container member 9 by forward movement in the direction of arrow B. In other words, the concave cavity 17b of the shell-like cover member 11 is able to slidingly receive the convex rear surface
15 of the container member 9. In the nesting position, an interference fit is formed between the container and cover members 9, 11 to releasably fasten them in the nesting position.

20 When the container and cover members 9,11 adopt the nesting configuration, an ergonomic unit is formed which is able to be easily, and comfortably, held by a hand 90 of a patient 92, as shown in FIGURE 1. In this mode, the outer casing part 3 is able to act as a holder or applicator of the drug delivery device 1.

25 As shown in FIGURE 5, for example, the outer surface 33 at the rear side of the container member 9 is provided with a window 35. As will be understood from FIGURES 4A and 4B, the window 35 is covered by the cover member 11 when in its second angular position. If the cover member 11 is transparent or semi-transparent, the window 35 is then visible through the cover member 11
30 when in its second angular position.

If need be, an indexing or detent mechanism could be provided for indexing the cover member 11 in one or more predetermined angular positions about the pivot axis A-A, for instance the first and/or second angular positions and/or angular positions therebetween. The user would then have a tactile
5 feedback indicating that the cover member 11 is in the correct angular position, e.g. for nesting with the container member 9. One way of achieving the indexing mechanism would be a male-and-female arrangement in which male (or female) surface features are formed in the outer surface 33 of the container member 9 at the required angular dispositions about the pivot axis A-A and one or more
10 complementary female (or male) surface features are correspondingly arranged on the inner surface of the hinge 13 about the knob 15. When the male feature is located in the, or one of the, female features (or vice-versa), the cover member 11 is indexed in a predetermined angular position. To move the cover member 11 to a new angular position, rotation of the cover member 11 about the pivot
15 axis A-A causes disconnection of the first indexing connection until the male and female features re-engage at a new angular position of the cover member 11

By way of example, a "ball-and-socket" indexing mechanism is shown in FIGURES 8 and 9 in which a circular array of protrusions 80 is formed on the
20 inner surface of the hinge 13 co-axially with the knob 15, and a complementary circular array of sockets 82 is formed in the outer surface 33 of the bevel 29 on the container member 9 co-axially with the pivot axis A-A. When the protrusions 80 are located in the complementary sockets 82, the cover member 11 is indexed in one of a plurality of different predetermined angular positions it can adopt
25 about the pivot axis A-A, for instance the first angular position of FIGURES 2 and 3 or the second angular position of FIGURES 4A and 4B. The cover member 11 is then able to be indexed in a new predetermined angular position by pivoting it about the pivot axis A-A to disconnect and re-engage the protrusions 80 and sockets 82, e.g. from the first angular position to the second angular position and
30 vice-versa.

In an alternative embodiment, an indexing mechanism may be provided which indexes the cover member 11 in an end angular position between the first

and second angular positions mentioned previously such that the cover member 11 does not cover the window 35 in the container member 9, thereby allowing the window 35 to be viewed by a user of the intranasal device 1.

5 Canister Unit

Turning attention now to FIGURES 10A to 10D, the canister unit 7 comprises an aerosol canister 10 of standard type which contains a drug formulated in a fluid propellant, e.g. a liquefied gas propellant such as a hydrofluoro alkane (HFA), for instance 1,1,1,2-tetrafluoroethane ($\text{CF}_3\text{CH}_2\text{F}$) (known as "HFA 134a") or 1,1,1,2,3,3,3-heptafluoro-n-propane ($\text{CF}_3\text{CHF}_2\text{CF}_3$) (known as "HFA 227") or a mixture thereof. The drug is typically for the treatment or prophylaxis of respiratory diseases or disorders, for example rhinitis. The drug may also be for the treatment or prophylaxis of other types of disease or disorder through systemic action of the drug. The canister unit 7 further comprises a dose counter head 12.

The canister 10 has a metal canister body 14 which, as known in the art, e.g. from metered dose inhalers (MDIs), has an open end which is capped by a valve assembly including a valve stem 16 which is mounted so it is movable relative to the canister body 14, between a retracted or open position relative to the canister body 14 in which the drug formulation is discharged from the canister 10 through the valve stem 16, and an extended or closed position relative to the canister body 14 in which the drug formulation is prevented from being discharged from the canister 10.

As known in the art, the valve assembly includes a biasing mechanism such as a spring (not shown) for biasing the valve stem 16 to the closed position. The valve assembly may be such as to further include a metering mechanism which operates so that a metered dose of the drug formulation is discharged when the valve stem 16 is in its open position. Typically, the valve assembly will have a metering chamber of fixed volume which in the closed position of the valve stem 16 is sealed from the external environment but in fluid communication

with the canister body 14 whereby the metering chamber is filled with the drug formulation, and which in the open position of the valve stem is sealed from the canister body 14 and its contents, but placed in fluid communication with the external environment so that the metered dose of the drug formulation in the chamber is discharged to the external environment through the valve stem 16.

In this embodiment of the invention the valve assembly is a metering valve which dispenses a metered dose of the drug formulation per actuation thereof. A suitable metering valve is disclosed in WO98/29321, the content of which is hereby incorporated herein by reference.

The dose counter head 12 of the canister unit 7 has a hollow plastics body 18 of a plastics material which is fixedly secured to the canister 10 over the outlet end of the canister 10 having the valve assembly. The dose counter body 18 is fixed to the canister 10 to prevent it being taken off the canister 10, although it is free to rotate about a longitudinal axis D-D of the canister unit 7. The dose counter body 18 may be fixed to the canister 10 in the manner described and shown in WO01/28887 (Glaxo/Brand *et al*), the content of which is hereby incorporated herein by reference.

As best shown in FIGURE 10D, the dose counter body 18 is formed with a display window 20. The dose counter head 12 further includes a dose counting mechanism (not shown) in the body 18 which, when actuated, advances a counter 22 thereof located in the window 20. When the counter 22 is advanced it results in the dose count shown thereby in the window 20 either being incremented to indicate the number of doses dispensed or, more preferably, decremented to show the number of doses left in the canister 10. The dose counter mechanism can take one of the forms described and shown in WO98/56444 (Glaxo/Rand *et al*) or Applicant's co-pending International patent application No. PCT/EP03/06466 (Applicant's Ref: PB60210), the contents of which are incorporated herein by reference.

An aperture 24 is provided in the outer surface of the dose counter body 18 to enable a driver to engage with the dose counting mechanism to advance the counter 22 when a dose of the drug formulation is dispensed from the canister 10 by the inner actuating part 5, as will be described in more detail hereinafter.

As shown in FIGURES 10A and 10B, the dose counter body 18 comprises a skirt-like lower section 26 and a U-shaped upper section 28. The dose counter body 18 also has a central opening 13 to the U-shaped upper section 28 through which the valve stem 16 protrudes. It will further be seen from FIGURES 10C and 10D that the dose counter window 20 is formed in a protrusion 32 in the outer peripheral surface of the U-shaped upper section 28.

Inner Actuating Part

Attention is now turned to FIGURES 11 to 15B which show the inner actuating part 5. The inner actuating part 5 is of a plastics material, preferably polypropylene, made by a moulding process, preferably by injection moulding.

As will be seen, the inner actuating part 5 is of tubular construction having a main body 37 defining an axially-oriented cavity 38. The main body 37 has an outer surface 39 having a rear section 40 of shape and size which is complementary to the shape and size of the inner surface 19 of the container member cavity 17a, thereby enabling the inner actuating part 5 to fit snugly in the container member cavity 17a, as shown in FIGURES 3 and 7, for example. More particularly, the rear section 40 of the main body outer surface 39 is provided with a series of axially-spaced, circumferential ribs 41a-c which act as spacers to position the inner actuating part 5 along a vertical axis C-C in the container member 9, as shown in FIGURES 6 and 7. Moreover, as further shown in FIGURE 7, the uppermost circumferential rib 41a is adapted to be snap fit underneath the locking rib 21a on the inner surface 19 of the container member 9.

FIGURES 11 to 13 show that the circumferential ribs 41a-c are intersected by longitudinal slots 42, 44. The longitudinal slots 42, 44 are positioned and sized so as to co-operate with the longitudinal ribs 27a, 27b on the inner surface 19 of the container member 9 of the outer casing part 3 to prevent rotation of the inner actuating part 5 in the container member 9 of the outer casing part 3.

It will further be seen that the inner actuating part 5 has a foot structure 43 which, as shown in FIGURE 7, stands on a base surface 60 of the cavity 17a of the container member 9. The foot structure 43 includes a notch 45 on its forwardmost surface 47 which engages with the locking rib 21b at the lower end 25 of the cavity 17a of the container member 9. When the locking features 21a, 21b; 41a, 45 of the container member 9 and the inner actuating part 5 respectively engage with one another, the inner actuating part 5 is releasably fixed in place in the container member 9. Only when a sufficient separation force is applied is the inner actuating part 5 released from the container member 9.

The rear section 40 of the main body 37 of the inner actuating part 5 has a longitudinally extending guide slot 49. The guide slot 49 is sized to slidably receive the protrusion 32 on the dose counter body 18. The canister unit 7 can only be inserted into the inner actuating part 5 when the protrusion 32 is aligned with the guide slot 49 in the inner actuating part 5, as shown in FIGURE 6. Thus, the guide slot 49 acts as a track along which the protrusion 32 slidably moves to insert the canister unit 7 into the inner actuating part 5 and retract it therefrom. The guide slot 49 also co-operates with the protrusion 32 to act as an anti-rotation feature which prevents rotation of the dose counter head 12 in the inner actuating part 5, as will be understood by reference to FIGURES 12 and 13.

As shown in FIGURE 13, the inner actuating part 5 also has longitudinal spacers 50 arranged circumferentially about the inner surface of the cavity 38 so that the canister unit 7 is generally co-axially mounted in the inner actuating part 5.

At the base of the cavity 38 of the inner actuating part 5 there is provided a hollow support 51 (so-called "stem block") having a sleeve 52 with a bore 53 sized to receive the valve stem 16 of the canister 10. It will be appreciated that when the canister unit 7 is inserted axially into the cavity 38, the U-shaped upper section 28 of the dose counter head 12 encloses the support 51 on three sides thereof. The hollow support 51 includes a hollow extension 55 which extends outwardly at an acute angle α to the outer periphery of the sleeve 52. The extension 55 has a bore 57 which opens into the bore 53 of the sleeve 52.

The bore 57 of the extension 55 is co-axial with a longitudinal axis E-E of a nozzle 59 which extends forwardly and upwardly at an acute angle β to the outer peripheral surface of the body 37 of the inner actuating part 5. The acute angles α , β may be the same, or substantially the same. As shown in FIGURE 1, the nozzle 59 is shaped and sized to be received in a nostril 94 of a nose 96 of the patient 92.

FIGURE 15A shows the canister unit 7 mounted in the inner actuating part 5 with the valve stem 16 held in the bore 53 of the sleeve 52 of the hollow support 51. As will be understood by comparing FIGURES 15A and 15B, in operation the canister body 14 (and counter head 12) is depressed in the direction of arrow F relative to the inner actuating part 5 and the valve stem 16, the stem 16 being held stationary in the hollow support 51. This relative movement of the canister body 14 to the valve stem 16 causes a metered dose of the drug formulation to be discharged through the valve stem 16 into the bore 53 of the sleeve 52. The drug formulation is then channeled by the extension 55 into the nozzle 59 for delivery to the patient's nostril 94. The biasing mechanism in the valve assembly causes the canister body 14 to re-adopt the inoperative position shown in FIGURE 15A on release of the depressing force F ready for the next actuation cycle.

30

It can therefore be seen from the above that the inner actuating part 5 contains all of the actuating elements for causing actuation of the canister 10 so that the drug formulation is discharged therefrom into the patient 92. In other

words, the inner actuating part 5 is adapted to actuate the canister 10 when separate from the outer casing part 3.

Moreover, the base of the cavity 38 of the inner actuating part 5 carries a
5 rack-like post 61 having a serrated outer profile 63 (teeth) which co-operates with
the dose counter mechanism such that on depression of the canister body 14 in
the inner actuating part 5 to its operative position shown in FIGURE 15B, the
rack-like post 61 drives a cog system in the dose counter mechanism (see
WO98/56444 and PCT/EP03/06466 *supra*) so that the counter 22 in the display
10 20 is advanced to reflect that the canister 10 has been actuated to dispense a
dose of the drug formulation.

It will be observed from FIGURES 11 to 13, for example, that the main
body 37 of the inner actuating part 5 has an aperture 100 through a side thereof
15 which is aligned with the rack-like post 61. The aperture 100 is left by that
member of the inner actuating part mould assembly used to form the post 61. In
this regard, it will be gathered from FIGURE 13 that the post 61 does not register
with the nozzle 59. That is to say, the post 61 is offset to the nozzle axis E-E
such that it would not be possible to have the mould member for the post 61
20 extracted through the nozzle 59. This is because the nozzle diameter has to be
small enough to be insertable into the patient's nostril 94 and the post 61 is
positioned to one side of the hollow support 51 which is in registration with the
nozzle 59 for fluid communication therebetween.

As will be realised, the rack-like post 61 can be replaced by any other
25 dose counter mechanism driver structure as dictated by the form of the dose
counter mechanism. Accordingly, the dose counter mechanism driver can take
the form of another type of mechanical element or a non-mechanical element, for
example. Again, reference may be had to WO98/56444 *supra*.

30

It can be seen from FIGURE 2 that once the canister unit 7 is assembled
with the inner actuating part 5 and this assembly snap-fitted into the outer casing
part 3, the outer casing part 3 acts as a protective casing for the canister unit 7

when in its closed state as it prevents actuation of the canister unit 7 and shields the nozzle 59 of the inner actuating part 5.

Operation

5

To use the intranasal device 1, the patient 92 moves the cover member 11 of the outer casing part 3 from the closed position shown in FIGURE 2 to the open position shown in FIGURE 3. The cover member 11 is then pivoted to the second angular position shown in FIGURE 4A and then nested with the container member 9, as shown in FIGURE 4B. Then, as shown in FIGURE 1, the patient 10 92 grips the outer casing member 3 in one hand 90 and inserts the nozzle 59 into the nostril 94. The patient 92 then actuates the device 1 by depressing the canister body 14 into the inner actuating part 5 relative to the valve stem 16 with the index finger 98. This results in a metered dose of the drug formulation being 15 delivered to the nostril.

Actuation of the device 1 can be confirmed by the patient 92 observing whether the dose counter 22 has been advanced (decremented/incremented). The patient 92 then closes the outer casing part 3 to protect the inner actuating 20 part 5 and canister unit 7 until the next dose is required to be dispensed.

As will be seen from FIGURE 1, when the outer casing part 3 is in its open state it acts as a holder/applicator for the patient 92 in the sense that the patient 92 is able to grip the outer casing part 3 in one hand 90 and to depress the 25 canister body 14 (and counter head 12) into the inner actuating part 5 with the index finger 98 to cause a dose of the drug formulation to be dispensed through the nozzle 59 and the counter 20 to be incremented/decremented.

One of the numerous advantages of the intranasal device 1 is the use of 30 separable outer casing and inner actuating parts 3, 5. Recalling that the inner actuating part 5 contains all of the functional features for actuating the canister unit 7, both from a drug delivery and dose counting point of view, this is the only part which needs to be tested and submitted for regulatory approval. The outer

casing part 3 does not affect the performance of the inner actuating part 5 in any way. This would be in contrast to the case where the outer and inner parts 3, 5 are integrally formed. In this instance, any change to the external shape and configuration after approval would necessitate a new application for approval since the alteration may have an adverse effect on the internal functional features, especially if the component is moulded from a plastics material.

So, the inner actuating part 5 is able to be designed first and then the decorative outer protective casing part 3 designed afterwards. In this way, the inner actuating part 5 can be tested and submitted for regulatory approval before the outer casing part 3 is finalised. This shortens the lead time for developing an approved drug delivery device. Moreover, the outer casing part 3 can be re-designed to maintain a contemporary appearance etc. without requiring a new round of regulatory tests.

Appropriate drugs (or medicaments) for use in the present invention, for instance forming part of a pharmaceutical aerosol formulation having a fluid propellant, e.g. a HFA propellant, such as HFA 134a or HFA 227, may be selected from, for example, analgesics, e.g., codeine, dihydromorphine, ergotamine, fentanyl or morphine; anginal preparations, e.g., diltiazem; antiallergics, e.g., cromoglycate (e.g. as the sodium salt), ketotifen or nedocromil (e.g. as the sodium salt); antiinfectives e.g., cephalosporins, penicillins, streptomycin, sulphonamides, tetracyclines and pentamidine; antihistamines, e.g., methapyrilene; anti- inflammatories, e.g., beclomethasone (e.g. as the dipropionate ester), fluticasone (e.g. as the propionate ester), flunisolide, budesonide, rofleponide, mometasone (e.g. as the furoate ester), ciclesonide, triamcinolone (e.g. as the acetonide), 6 α , 9 α -difluoro-11 β -hydroxy-16 α -methyl-3-oxo-17 α -propionyloxy-androsta-1,4-diene-17 β -carbothioic acid S-(2-oxo-tetrahydro-furan-3-yl) ester or 6 α , 9 α -Difluoro-17 α -[(2-furanylcarbonyl)oxy]-11 β -hydroxy-16 α -methyl-3-oxo-androsta-1,4-diene-17 β -carbothioic acid S-fluoromethyl ester; antitussives, e.g., noscapine; bronchodilators, e.g., albuterol (e.g. as free base or sulphate), salmeterol (e.g. as xinafoate), ephedrine,

adrenaline, fenoterol (e.g. as hydrobromide), formoterol (e.g. as fumarate), isoprenaline, metaproterenol, phenylephrine, phenylpropanolamine, pirbuterol (e.g. as acetate), reproterol (e.g. as hydrochloride), rimiterol, terbutaline (e.g. as sulphate), isoetharine, tulobuterol or 4-hydroxy-7-[2-[[2-[[3-(2-phenylethoxy)propyl]sulfonyl]ethyl]amino]ethyl-2(3H)-benzothiazolone; PDE4 inhibitors e.g. cilomilast or roflumilast; leukotriene antagonists e.g. montelukast, pranlukast and zafirlukast; [adenosine 2a agonists, e.g. 2R,3R,4S,5R)-2-[6-Amino-2-(1S-hydroxymethyl-2-phenyl-ethylamino)-purin-9-yl]-5-(2-ethyl-2H-tetrazol-5-yl)-tetrahydro-furan-3,4-diol (e.g. as maleate)]; [α 4 integrin inhibitors e.g. (2S)-3-[4-({[4-(aminocarbonyl)-1-piperidiny]carbonyl}oxy)phenyl]-2-(((2S)-4-methyl-2-[[2-(2-methylphenoxy) acetyl]amino]pentanoyl)amino) propanoic acid (e.g. as free acid or potassium salt)], diuretics, e.g., amiloride; anticholinergics, e.g., ipratropium (e.g. as bromide), tiotropium, atropine or oxitropium; hormones, e.g., cortisone, hydrocortisone or prednisolone; xanthines, e.g., aminophylline, choline theophyllinate, lysine theophyllinate or theophylline; therapeutic proteins and peptides, e.g., insulin or glucagons. It will be clear to a person skilled in the art that, where appropriate, the medicaments may be used in the form of salts, (e.g., as alkali metal or amine salts or as acid addition salts) or as esters (e.g., lower alkyl esters) or as solvates (e.g., hydrates) to optimise the activity and/or stability of the medicament and/or to minimise the solubility of the medicament in the propellant.

Preferably, the medicament is for the treatment of inflammatory and/or allergic conditions of the nasal passages such as rhinitis, e.g. seasonal and perennial rhinitis as well as other local inflammatory conditions such as asthma, COPD and dermatitis. Preferably, the medicament is an anti-inflammatory compound for the treatment of asthma or rhinitis.

It is to be understood that the exemplary embodiments of the present invention outlined above are for the purposes of illustration only, and that the invention can be modified, varied and take on other guises within the scope of the appended claims. Mindful of this, the use of reference numerals in the claims is not to be taken as having a limiting effect on the scope of the claims.

For the avoidance of doubt, the use herein of terms such as "generally", "substantially", "about" and the like when referring to a parameter of the invention is meant to include the absolute parameter.

CLAIMS

1. A container (3) having a first part (11), a second part (9) and a hinge (13) through which the first and second parts are hingeably connected so that the parts are hingeable relative to one another between a first position which places the container in a closed state and a second position which places the container in an open state, and wherein the first and second parts are pivotally connected (15, 31) so that the parts are able to be pivoted relative to one another to different angular positions.
2. The container of claim 1 adapted such that the first and second parts are not pivotal relative to one another when the container is in the closed state.
3. The container of claim 2 wherein in the closed state the first and second parts interengage one another so as to prevent pivotal movement therebetween.
4. The container of claim 3 wherein the interengagement is between respective lip structures (2a, 2b) of the first and second parts.
5. The container of any one of the preceding claims wherein the hinge is a living hinge.
6. The container of any one of the preceding claims wherein the first and second parts have locking elements (4,6) which interengage in the closed state of the container to lock the container in the closed state.
7. The container of claim 6 wherein the locking elements form a snap fit connection of the first and second parts in the closed state of the container.
8. The container of any one of the preceding claims wherein the hinge is pivotally mounted (15, 31) to the second part for enabling the relative pivotal movement of the first and second parts.

9. The container of any one of the preceding claims wherein the hinge is statically mounted to the first part.
10. The container of claims 8 and 9 wherein the hinge forms an integral part of the first part and is pivotally mounted to the second part.
11. The container of any one of the preceding claims wherein the first part is pivotal to a first angular position disposed behind the second part.
12. The container of claim 11 wherein the first part is pivotal to the first angular position after the container is in the open state.
13. The container of claim 11 or 12 wherein in the first angular position the first and second parts are adapted to nest together in a nesting state.
14. The container of any one of claims 11 to 13 wherein the second part has a rear surface in which is provided a reading feature (35), the first part covers the reading feature in the first angular position and has a viewing feature to enable the reading feature to be viewed through the first part when in the first angular position.
15. The container of claim 14 wherein the first part is at least in part made from a material sufficiently transparent to enable the reading feature to be viewed therethrough when the first part is in the first angular position.
16. The container of any one of the preceding claims further having a detent mechanism (80, 82) for detenting the first and second parts in different angular positions.
17. The container of claims 11 and 16 wherein the second part has a rear surface in which is provided a reading feature (35) and the detent mechanism is adapted to detent the first part in the first angular position, which first angular position provides an unimpeded view of the reading feature on the second part.

18. The container of any one of claims 14, 15 or 17 wherein the reading feature is a window for viewing the contents of the container.
- 5 19. The container of any one of the preceding claims wherein the first and second parts form an enclosing structure when in the closed state.
20. The container of claim 19 wherein the enclosing structure is an outer structure (3) and wherein the container includes an inner part (5) releasably,
10 fixably securable in one of the first and second parts so as to be enclosed by the outer structure.
21. The container of claim 20 wherein the inner part is adapted to be snap-fitted in one of the first and second parts.
- 15 22. The container of claim 20 or 21 in which the inner part is securable in the second part.
23. The container of claim 20, 21 or 22 in which the inner part is adapted to
20 hold a product (7) in the container.
24. The container of claim 23 in which the product is a package with contents to be dispensed.
- 25 25. The container of claim 24 in which the inner part is a dispenser with a dispensing mechanism (51) for dispensing the contents of the package.
26. The container of claim 25 in which the dispensing mechanism operates through relative movement between the dispenser and the package when the
30 dispenser is fixedly secured in the outer structure.
27. The container of claim 25 or 26 in which the dispenser has a delivery nozzle (59) through which the contents of the package are dischargeable.

28. The container of any one of claims 25 to 27 in which the dispenser is an intranasal dispenser (1).
- 5 29. The container of any one of claims 25 to 28 when appendant on claim 14, 15 or 17 including the package, the package and dispenser forming a dispenser assembly, the package containing multiple doses of the contents and the dispenser assembly having a dose counter (12) for counting the number of doses
10 feature when the dispenser assembly is secured in the container.
30. The container of any one of claims 25 to 28 wherein the package is an aerosol canister with fluidic contents and having a valve (16) openable by the dispensing mechanism on relative movement of the canister to the dispenser for
15 release of a dose of the fluidic contents from the dispenser.
31. The container of claim 30 in which the valve has a stem (16) through which the fluidic contents is dispensed from the dispenser on relative movement thereof to the canister and in which the dispenser has a stand (51) adapted to
20 receive the stem in static relation thereto whereby the canister is able to be moved relative to the stem when received in the stand for dispensing of the fluidic contents.
32. The container of any one of claims 24 to 28, 30 and 31 including the
25 package.
33. The container of claim 32 in which the contents of the package is a pharmaceutical composition.
- 30 34. A container substantially as hereinbefore described with reference to, and as illustrated by, the accompanying FIGURES of drawings.

35. A medicament dispensing system having the container of any one of the preceding claims.

Fig. 1

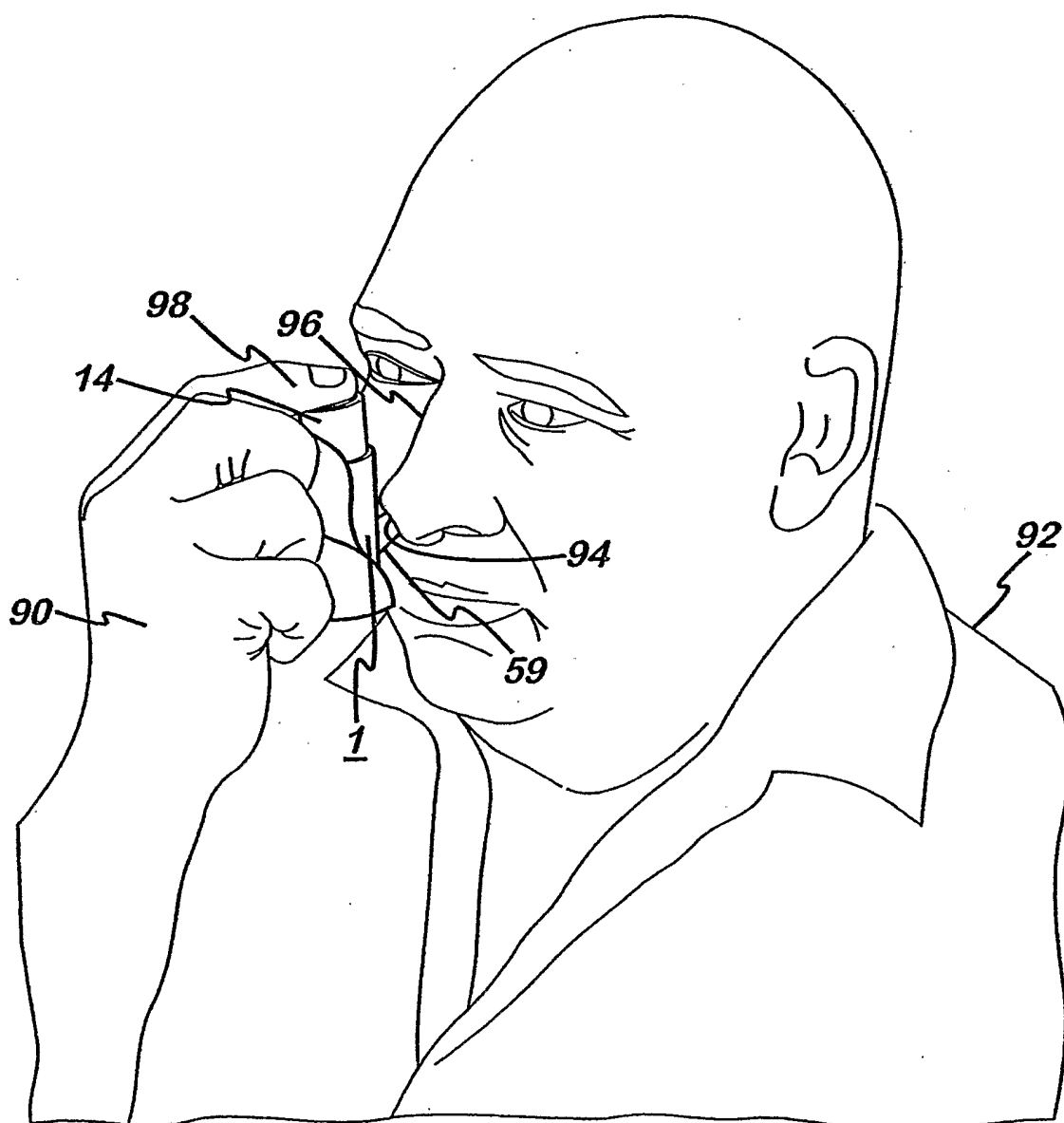

Fig. 3

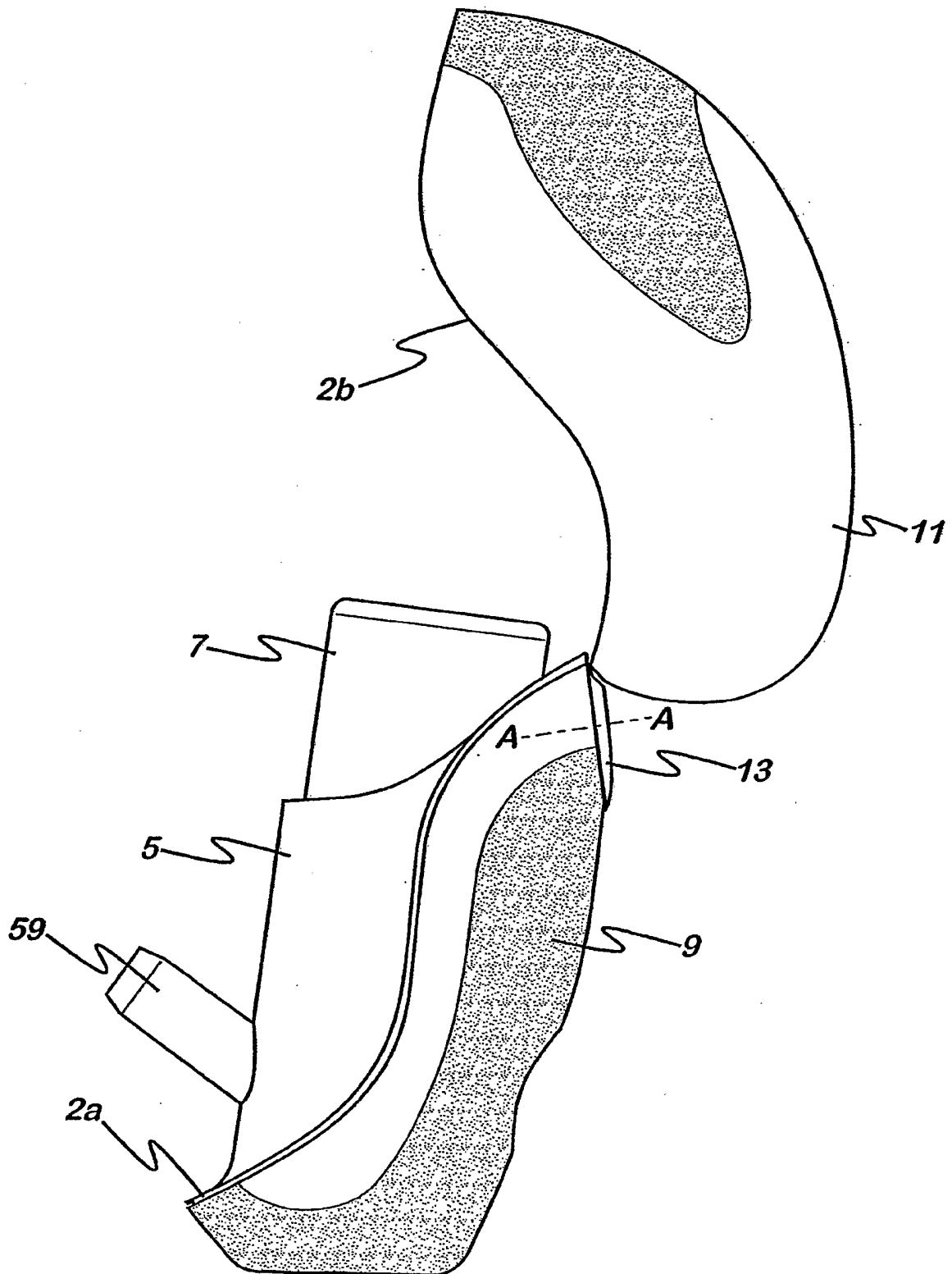

Fig. 4A

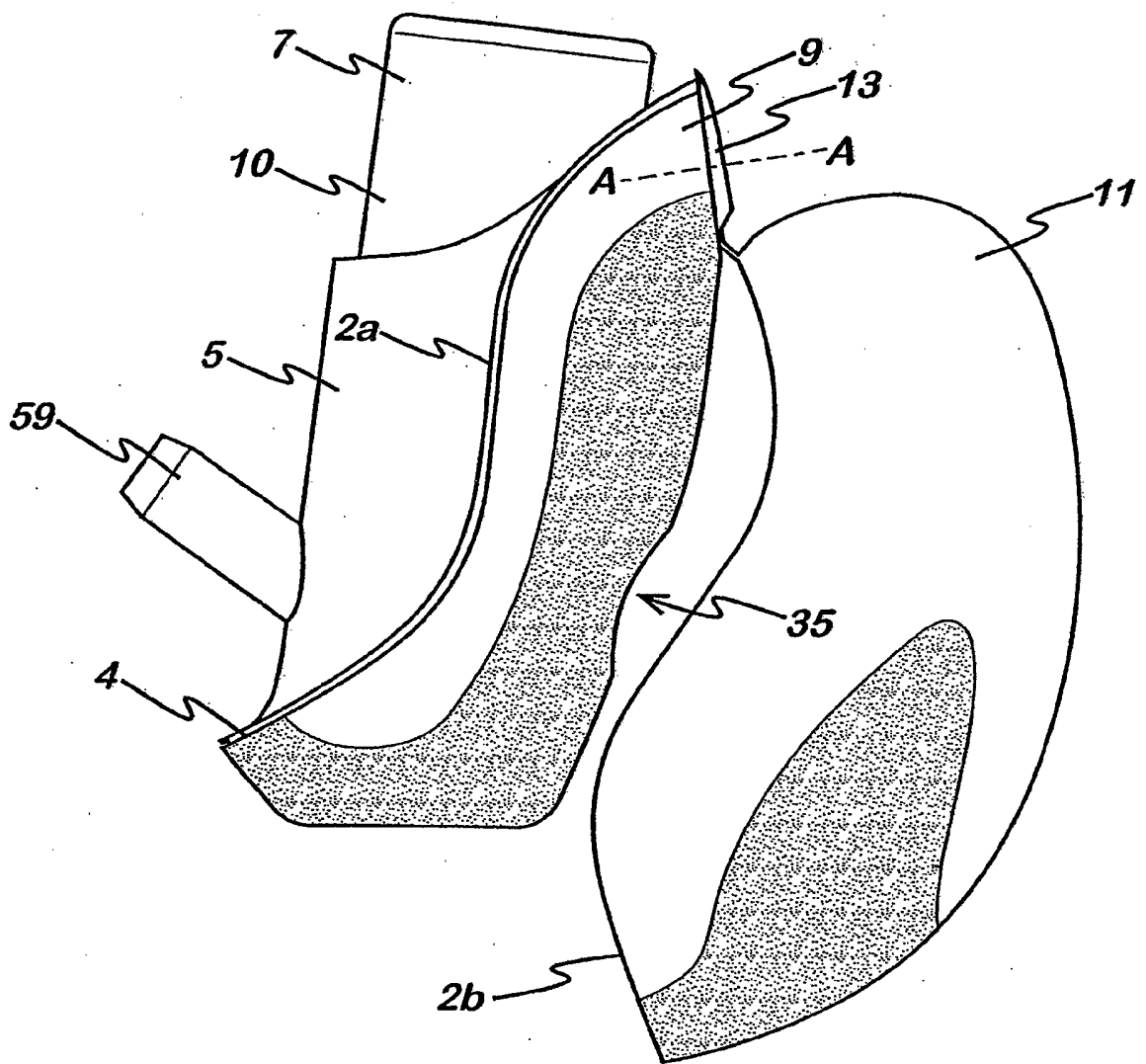

Fig. 4B

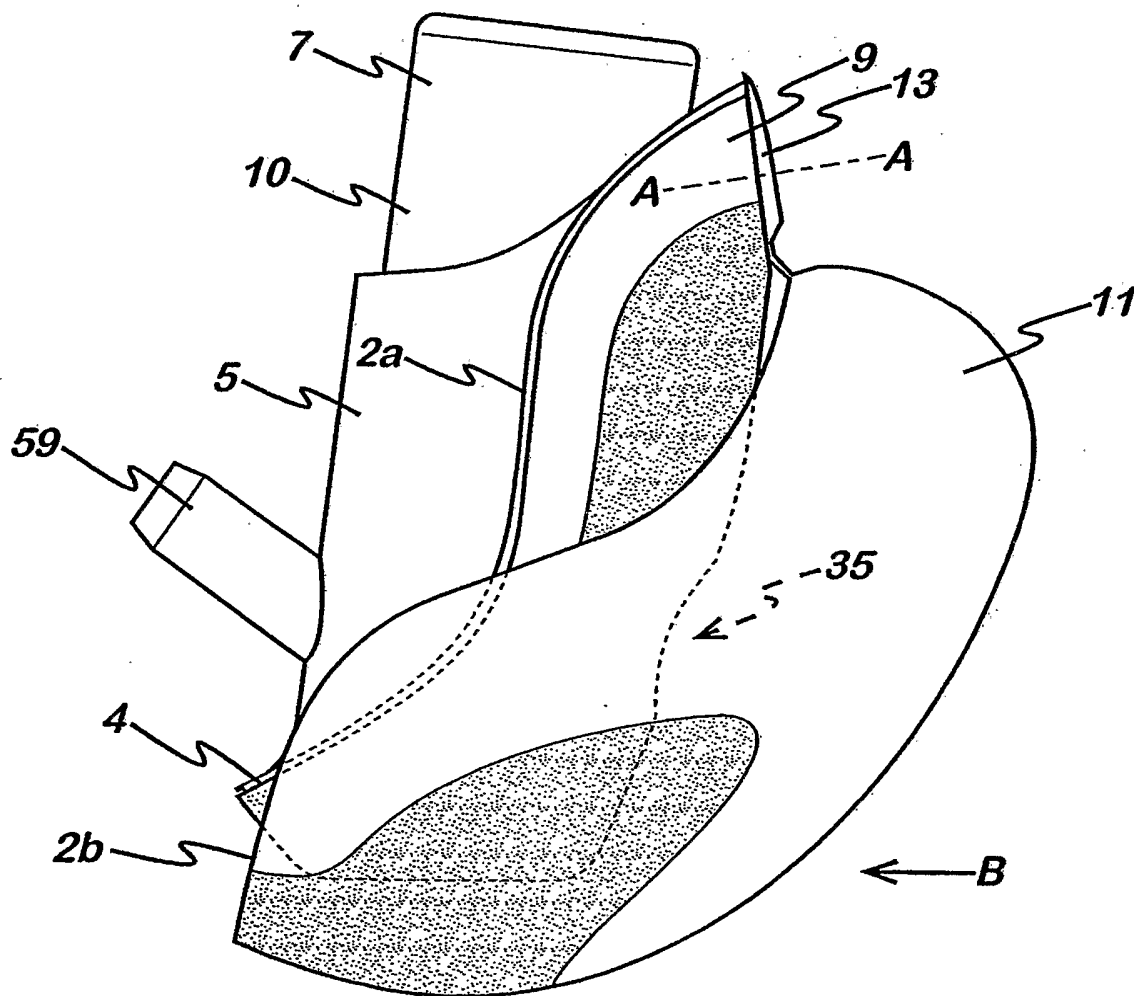
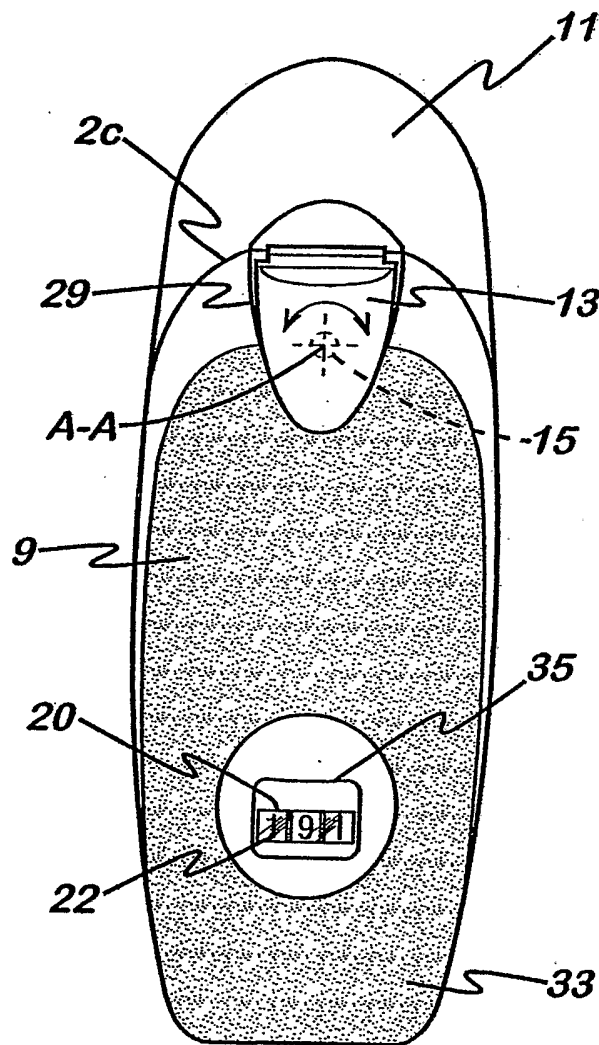

Fig. 5



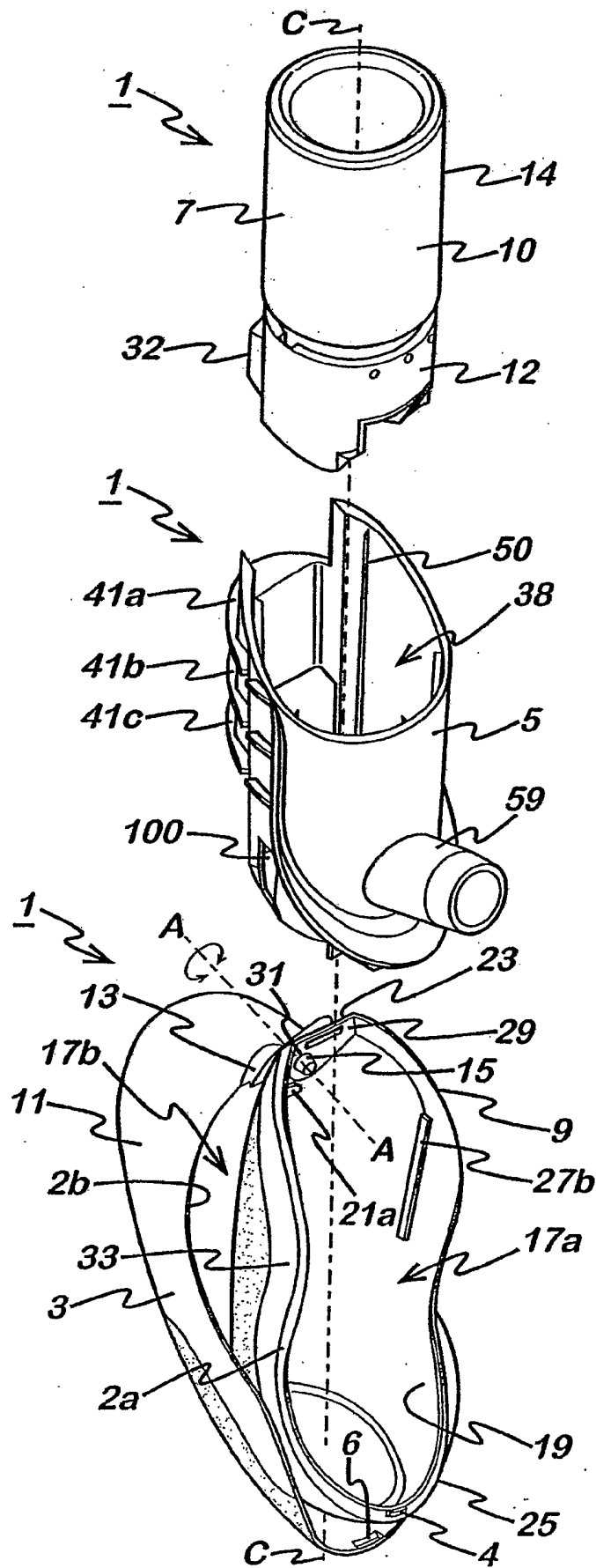

Fig. 6

Fig. 7

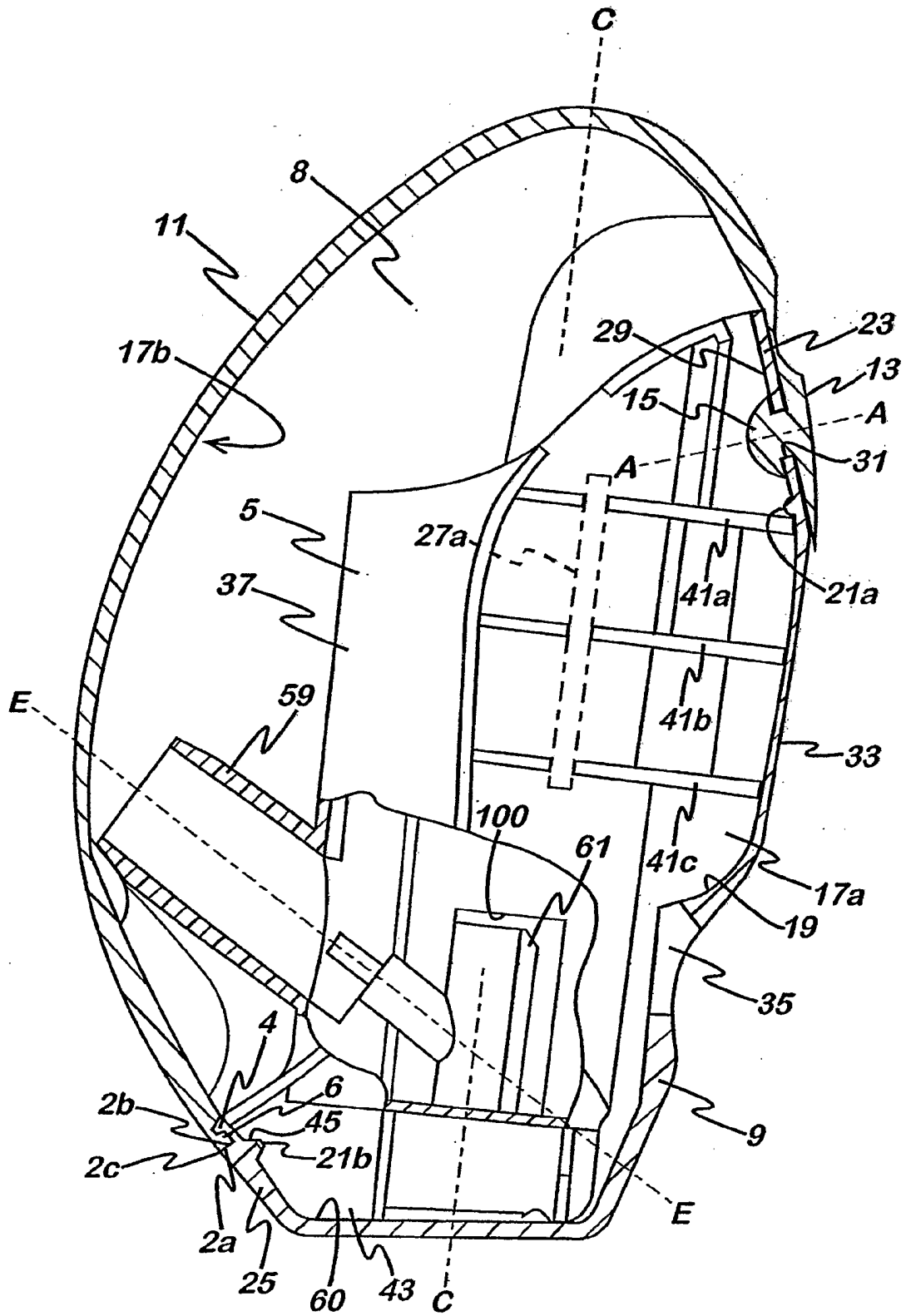

Fig. 8

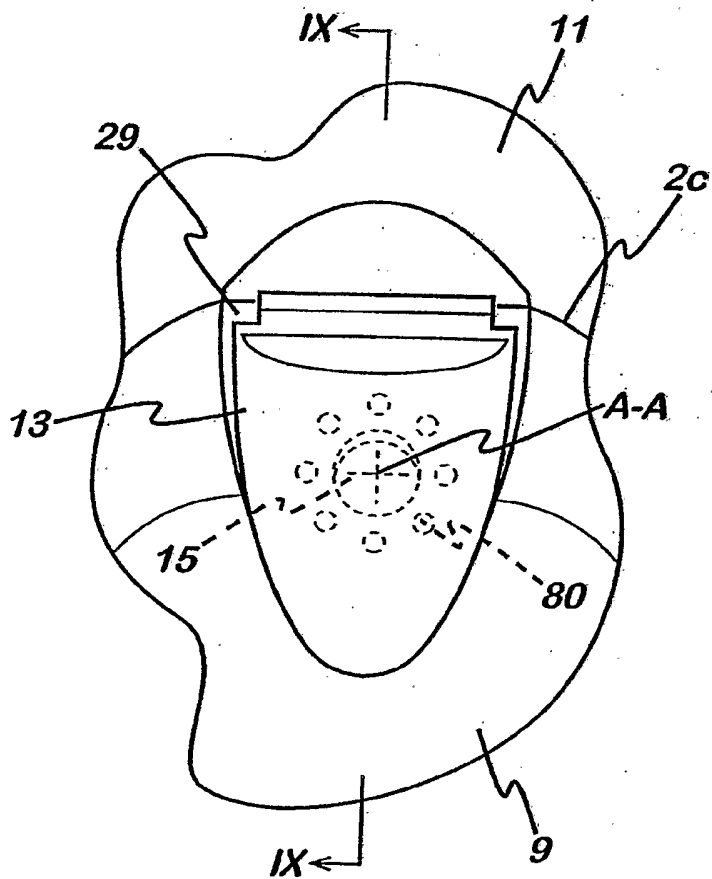

Fig. 9

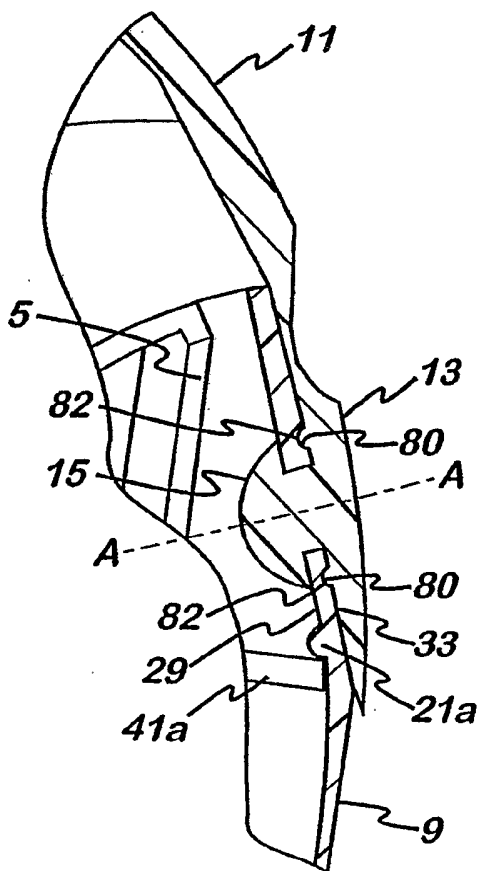
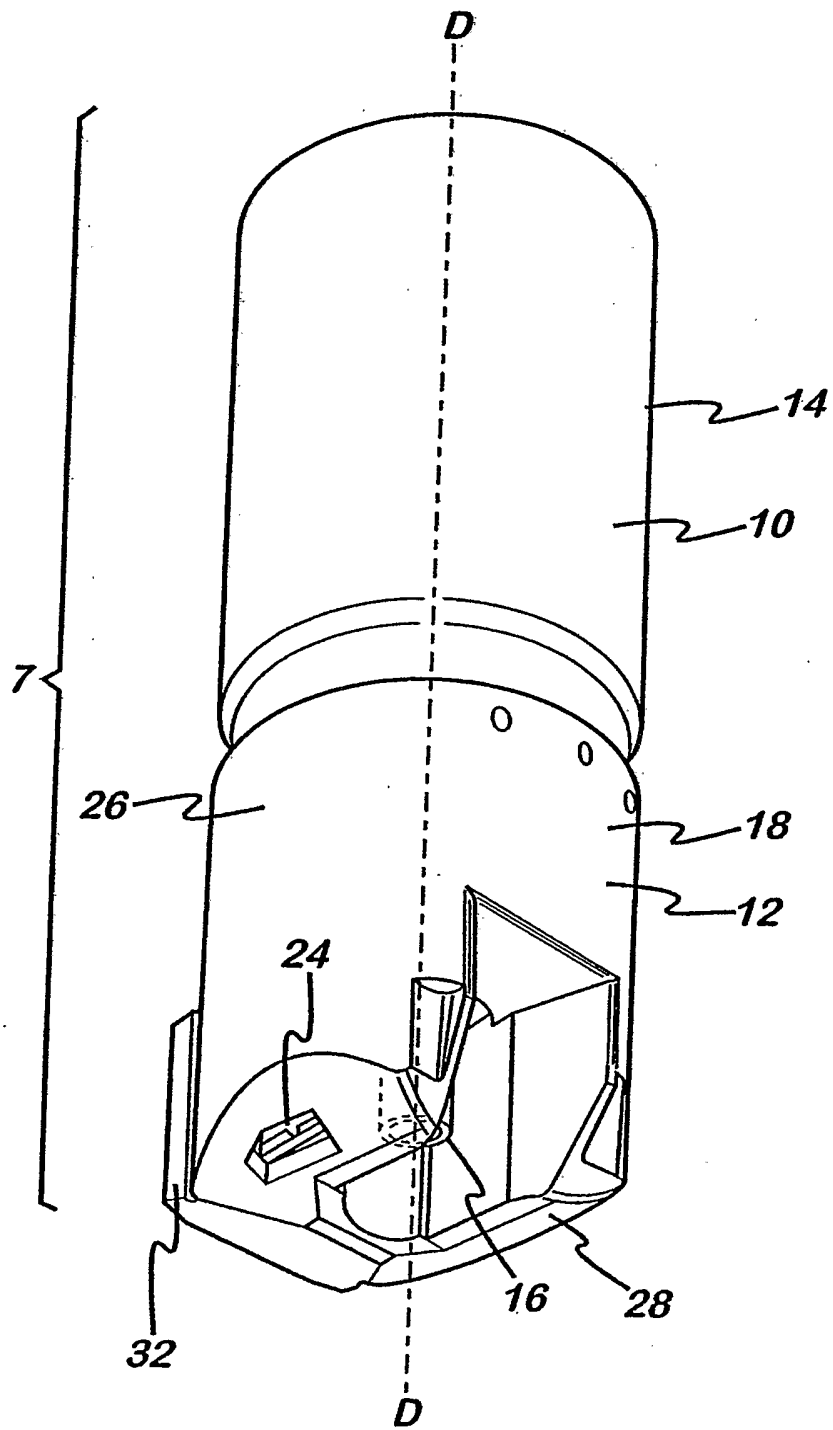

Fig. 10A



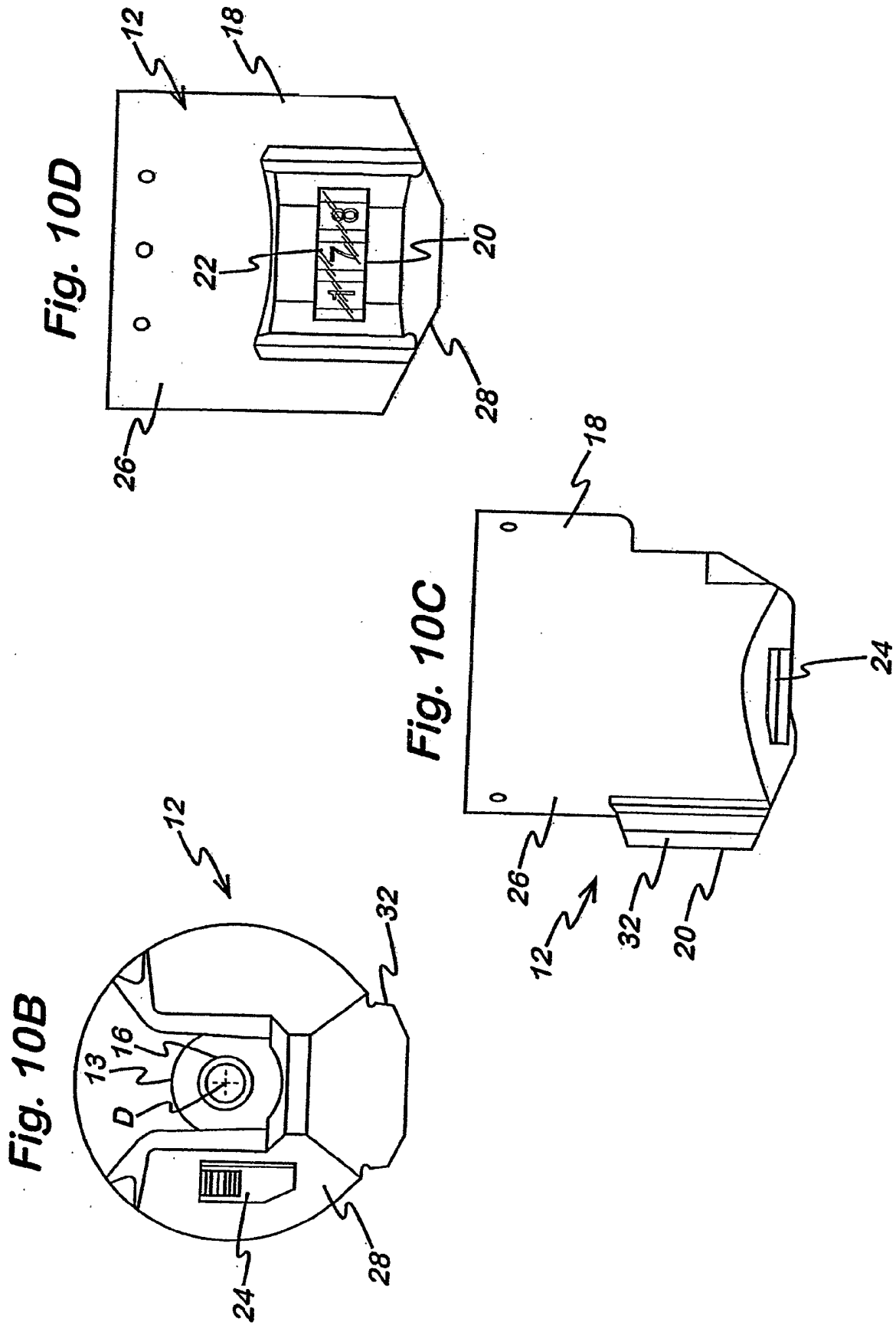

Fig. 12

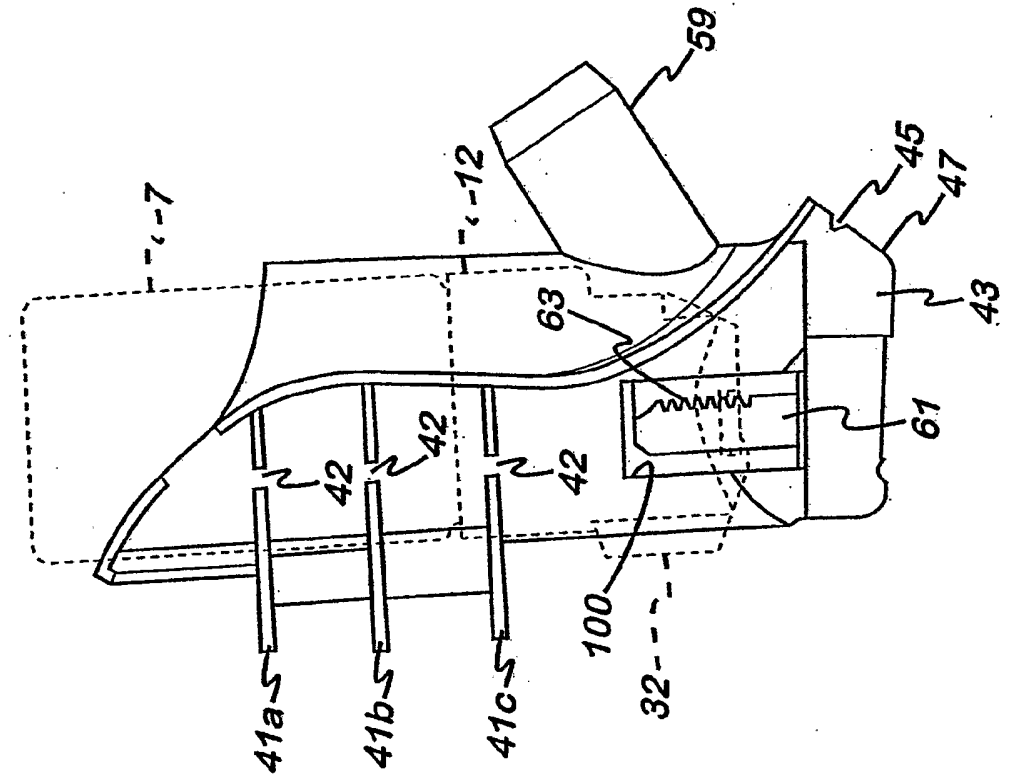

Fig. 11

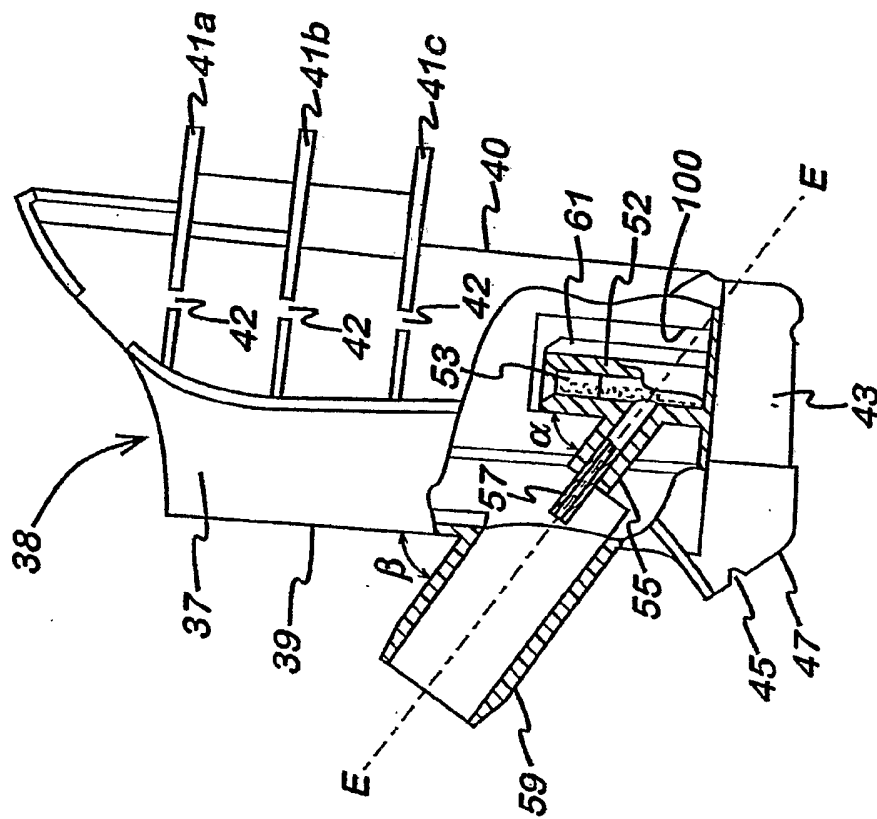

Fig. 13

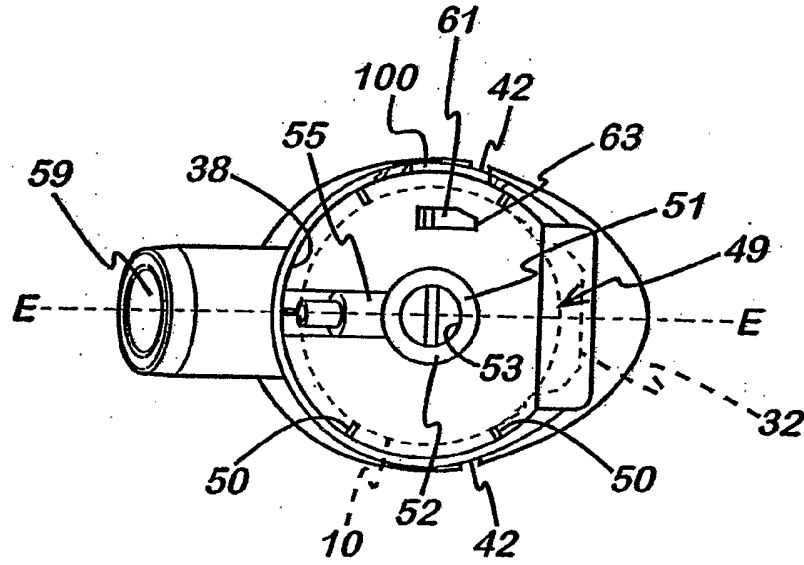

Fig. 14

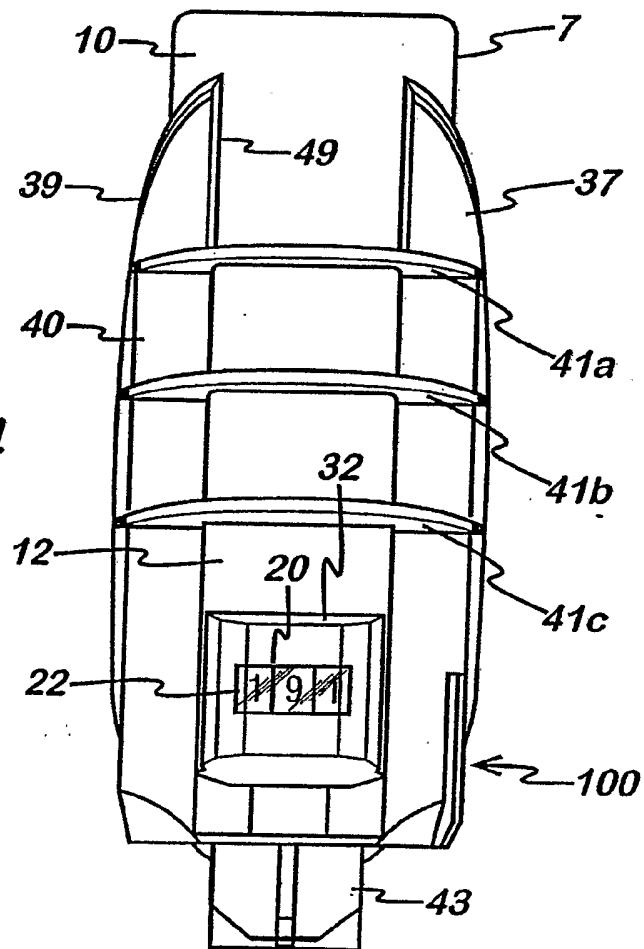

Fig. 15A

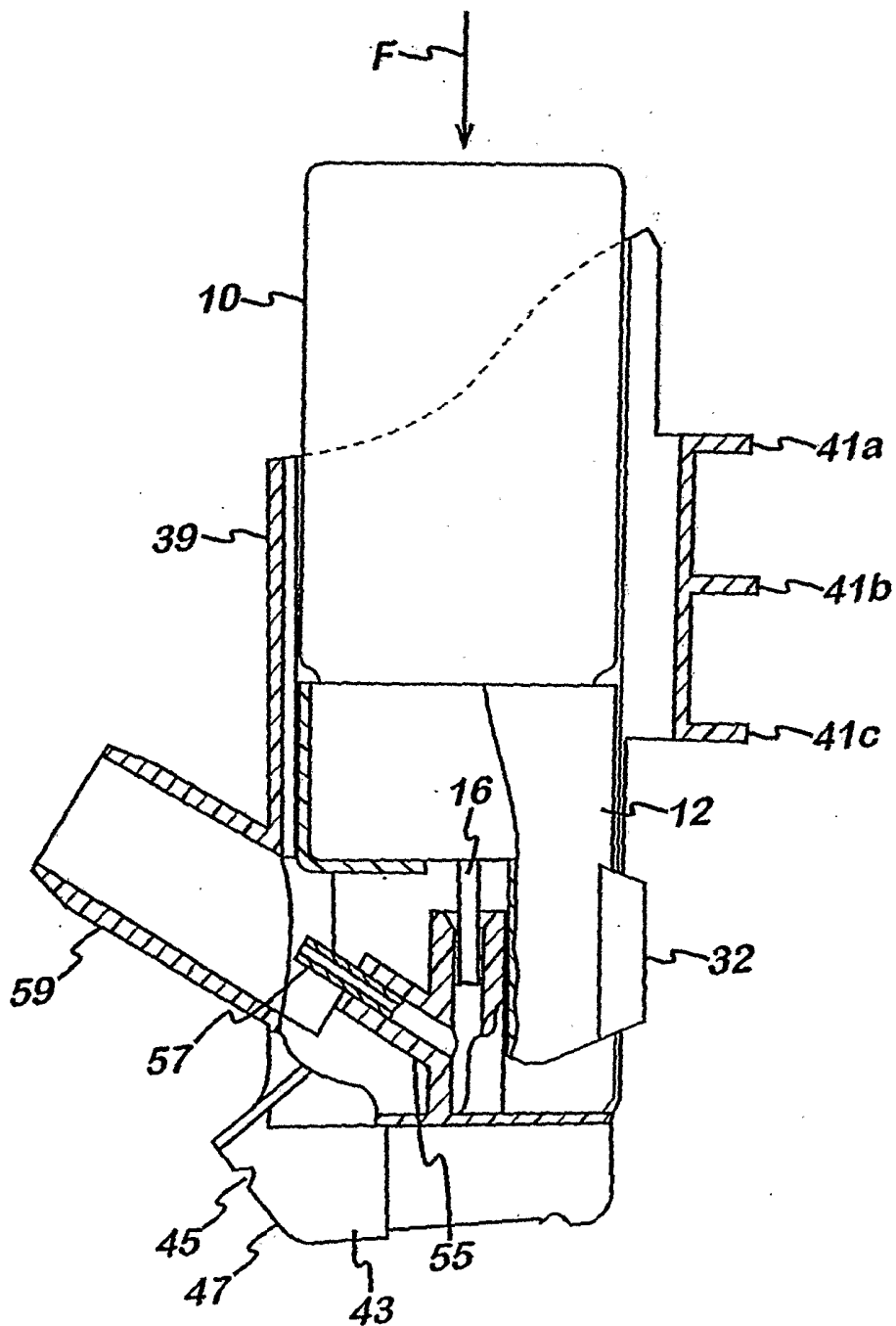
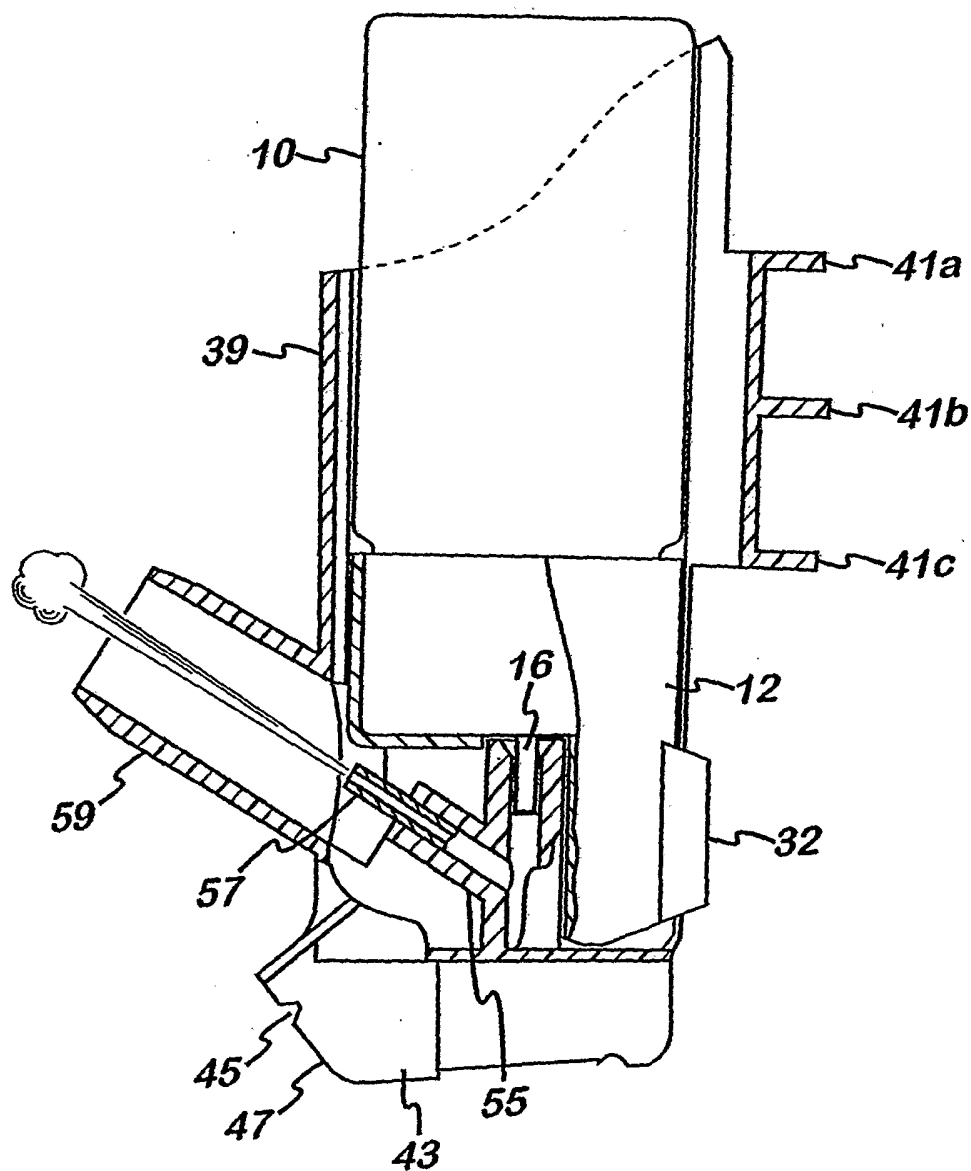

Fig. 15B



INTERNATIONAL SEARCH REPORT

International Application No
PCT/EP 03/12435

A. CLASSIFICATION OF SUBJECT MATTER
IPC 7 B65D43/16 B65D83/14

According to International Patent Classification (IPC) or to both national classification and IPC

B. FIELDS SEARCHED

Minimum documentation searched (classification system followed by classification symbols)
IPC 7 B65D A61M A45C E05D

Documentation searched other than minimum documentation to the extent that such documents are included in the fields searched

Electronic data base consulted during the international search (name of data base and, where practical, search terms used)

EPO-Internal

C. DOCUMENTS CONSIDERED TO BE RELEVANT

Category *	Citation of document, with indication, where appropriate, of the relevant passages	Relevant to claim No.
A	US 3 865 279 A (JAMES MICHAEL) 11 February 1975 (1975-02-11) figures <p style="text-align: center;">-----</p>	1

Further documents are listed in the continuation of box C.

Patent family members are listed in annex.

* Special categories of cited documents :

- *A* document defining the general state of the art which is not considered to be of particular relevance
- *E* earlier document but published on or after the international filing date
- *L* document which may throw doubts on priority claim(s) or which is cited to establish the publication date of another citation or other special reason (as specified)
- *O* document referring to an oral disclosure, use, exhibition or other means
- *P* document published prior to the international filing date but later than the priority date claimed

- *T* later document published after the international filing date or priority date and not in conflict with the application but cited to understand the principle or theory underlying the invention
- *X* document of particular relevance; the claimed invention cannot be considered novel or cannot be considered to involve an inventive step when the document is taken alone
- *Y* document of particular relevance; the claimed invention cannot be considered to involve an inventive step when the document is combined with one or more other such documents, such combination being obvious to a person skilled in the art.
- *&* document member of the same patent family

Date of the actual completion of the international search

23 March 2004

Date of mailing of the international search report

31/03/2004

Name and mailing address of the ISA
 European Patent Office, P.B. 5818 Patentlaan 2
 NL - 2280 HV Rijswijk
 Tel. (+31-70) 340-2040, Tx. 31 651 epo nl,
 Fax: (+31-70) 340-3016

Authorized officer

 Bridault, A

INTERNATIONAL SEARCH REPORT

International application No.
PCT/EP 03/12435

Box I Observations where certain claims were found unsearchable (Continuation of item 1 of first sheet)

This International Search Report has not been established in respect of certain claims under Article 17(2)(a) for the following reasons:

1. Claims Nos.:
because they relate to subject matter not required to be searched by this Authority, namely:

2. Claims Nos.: 34
because they relate to parts of the International Application that do not comply with the prescribed requirements to such an extent that no meaningful International Search can be carried out, specifically:
see FURTHER INFORMATION sheet PCT/ISA/210

3. Claims Nos.:
because they are dependent claims and are not drafted in accordance with the second and third sentences of Rule 6.4(a).

Box II Observations where unity of invention is lacking (Continuation of item 2 of first sheet)

This International Searching Authority found multiple inventions in this international application, as follows:

1. As all required additional search fees were timely paid by the applicant, this International Search Report covers all searchable claims.

2. As all searchable claims could be searched without effort justifying an additional fee, this Authority did not invite payment of any additional fee.

3. As only some of the required additional search fees were timely paid by the applicant, this International Search Report covers only those claims for which fees were paid, specifically claims Nos.:

4. No required additional search fees were timely paid by the applicant. Consequently, this International Search Report is restricted to the invention first mentioned in the claims; it is covered by claims Nos.:

Remark on Protest

- The additional search fees were accompanied by the applicant's protest.
- No protest accompanied the payment of additional search fees.

FURTHER INFORMATION CONTINUED FROM PCT/ISA/ 210

Continuation of Box I.2

Claims Nos.: 34

The claim does not comply with Rule 6.2.a PCT.

The applicant's attention is drawn to the fact that claims relating to inventions in respect of which no international search report has been established need not be the subject of an international preliminary examination (Rule 66.1(e) PCT). The applicant is advised that the EPO policy when acting as an International Preliminary Examining Authority is normally not to carry out a preliminary examination on matter which has not been searched. This is the case irrespective of whether or not the claims are amended following receipt of the search report or during any Chapter II procedure. If the application proceeds into the regional phase before the EPO, the applicant is reminded that a search may be carried out during examination before the EPO (see EPO Guideline C-VI, 8.5), should the problems which led to the Article 17(2) declaration be overcome.

INTERNATIONAL SEARCH REPORT

Information on patent family members

International Application No
PCT/EP 03/12435

Patent document cited in search report		Publication date	Patent family member(s)	Publication date
US 3865279	A	11-02-1975	GB 1402638 A	13-08-1975
			AU 5744373 A	09-01-1975
			BE 801453 A1	26-12-1973
			CA 995540 A1	24-08-1976
			CH 553700 A	13-09-1974
			DE 2332076 A1	03-01-1974
			DK 146675 B	05-12-1983
			ES 416301 A1	01-03-1976
			FI 59337 B	30-04-1981
			FR 2190478 A1	01-02-1974
			IE 38017 B1	07-12-1977
			IT 985757 B	20-12-1974
			JP 49064286 A	21-06-1974
			JP 54056993 U	19-04-1979
			LU 67886 A	31-08-1973
			NL 7308470 A , B,	02-01-1974
			NO 137481 B	28-11-1977
			ZA 7304105 A	25-09-1974
