

No. 657,III.

Patented Sept. 4, 1900.

E. K. HAYES.
SWING.

(Application filed Sept. 23, 1899.)

(No Model.)

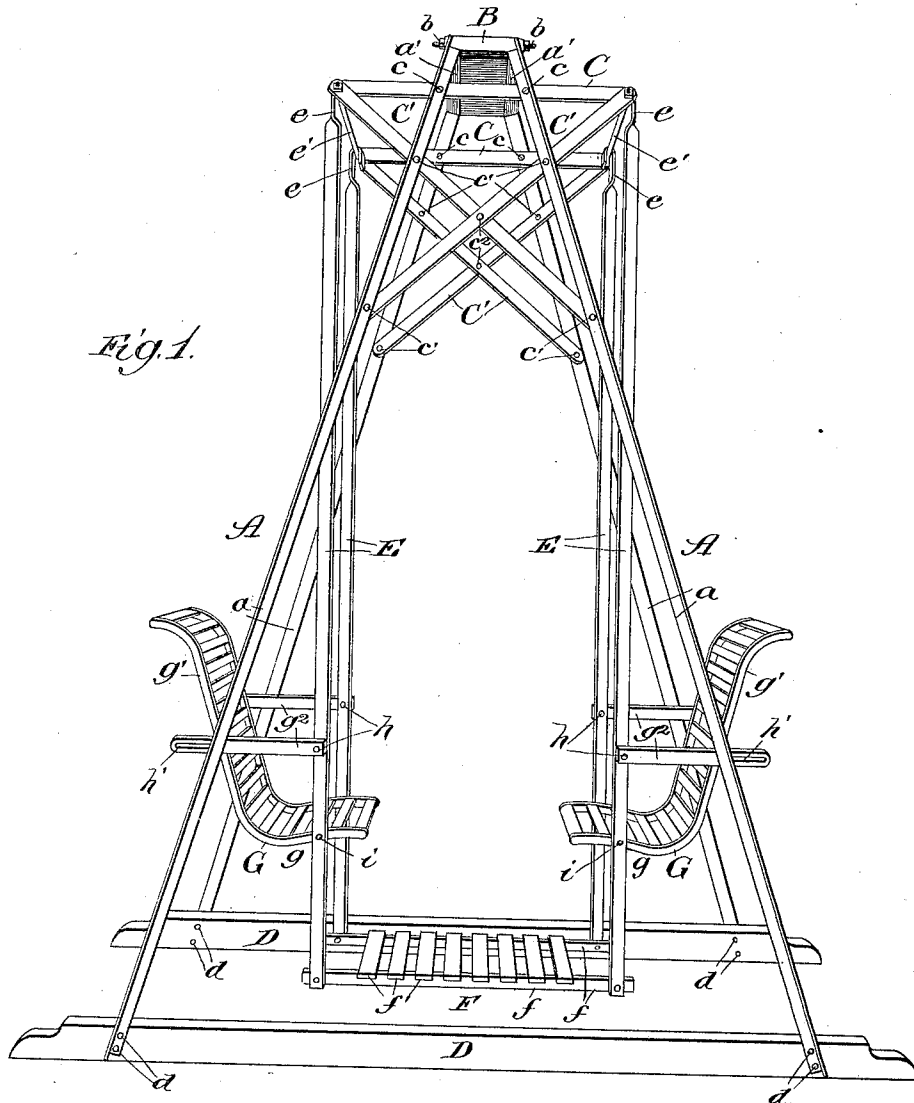
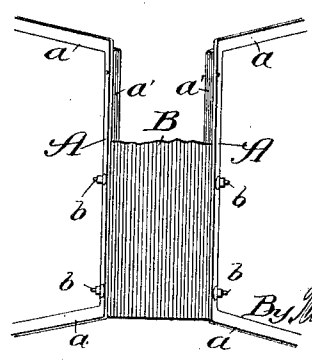

Fig. 1.

Fig. 2.



Witnesses:
Carl C. Gaylord,
Lute S. Allen

Inventor:
Eugenio H. Hayes,
 By *William W. Dunning* & *William W. Sheridan*
Attys

UNITED STATES PATENT OFFICE.

EUGENIO K. HAYES, OF GALVA, ILLINOIS.

SWING.

SPECIFICATION forming part of Letters Patent No. 657,111, dated September 4, 1900.

Application filed September 23, 1899. Serial No. 731,413. (No model.)

To all whom it may concern:

Be it known that I, EUGENIO K. HAYES, a citizen of the United States, residing at Galva, in the county of Henry and State of Illinois, have invented a certain new and useful Improvement in Swings, of which the following is a specification.

My invention relates, primarily, to portable swings or swings which after being set up can be moved around or changed as to location in the yard or other place where set up without the necessity of taking the swing down. Swings of this class require to be strong and rigid to withstand the usage to which they are subjected, and they should also be light and compact in order to be easily and quickly handled.

The principal object of my invention is to construct a swing that will be strong, rigid, and durable and at the same time symmetrical and light, employing in the construction light material without sacrificing the strength and rigidity of the parts.

The invention consists in the features, combinations, and details of construction herein-after described and claimed.

In the drawings illustrating my invention, Figure 1 is an elevation in perspective showing the swing set up; and Fig. 2 a top or plan view of the upper end of the supporting-frame standards and the bridge or block, showing the latter partly broken away.

In constructing my invention and applying the same to a swing I make a frame of two standards or uprights A. Each standard or upright is made from a single piece of metal, preferably high-carbon steel, rolled or otherwise formed into shape to have a right-angle conformation in cross-section, presenting a lateral or side flange or wing and a transverse or edge flange or wing when set up for use. Each standard has side pieces or legs *a* and a top or cross piece *a'*, formed by bending the single piece of material into a yoke or U shape. The legs of the standards have an outward or transverse spread at the bottom and are to be set inclined to each other and connected at their upper end by a bridge or tie piece B, preferably a block of wood, held in place by tie-bolts *b*. A cross-arm C is secured to each standard at the upper end thereof by bolts *c*, and running from the end of

each cross-piece is a diagonal support C', secured to the side wings of the pieces or legs of the standards by bolts *c'* and secured together at the crossing-point, which is the central vertical line between the standards, by a bolt *c²*. The cross pieces or arms and the diagonal supports form the head from which the swing-bars are suspended, and the construction of this head and the manner of attaching it to the standards is such that the push and pull in swinging and the thrust of the movement of the swing is received and borne by the cross arms or pieces and the diagonal supports and transmitted uniformly to and carried by the supporting frame-pieces or standards, so that the weight of the occupants and the movements of the swing are uniformly and evenly borne and distributed on the head and the supporting-frame, rendering it practically impossible for the swing to tip endwise in ordinary use. The frame-pieces or standards are secured at their lower ends to side timbers or supports D by bolts *d*, so as to have a lateral inclination by which, in connection with the transverse spread of the side pieces or legs and the head-blocks, the standards brace each other both laterally and transversely against strain in use. The suspension or swing bars E, two for each side of the swing, are mounted or suspended by eyes or hooks *e* on a cross rod or bar *e'* at the outer ends of the cross-arms C, which rod also secures together the outer ends of the cross and diagonal arms. The platform F, composed of side rails *f* and cross-pieces *f'*, is pivotally connected to and between the lower ends of the suspension or swing bars E, and the transverse spread of the standards and timbers or supports D is sufficient to leave a clear space between the standards and the platform and seats for the swinging movements without danger to the occupant of a seat. The seats G, one for each side of the swing, are each formed with a seat portion *g* and a back *g'*, and the seat portion is supported between the swing-bars by pins or pivots *i*. Each seat has an arm or side bar *g²*, attached by a pin or pivot *h* to the bar of the swing and having at the rear end a slot *h'*, by means of which and a suitable bolt and thumb-nut on the back of the seat or other suitable adjusting device the in-

clination of the seat as a whole can be adjusted and the seat locked in its adjusted position.

The standards or supports A can be made of exceedingly light material, having a right-angle formation, as such formation gives great strength and rigidity thereto, one wing or flange supporting the other. The two standards, made of right-angle material set at a lateral inclination to each other and having a transverse spread, form a wide base bolted to the timbers or supports at the bottom. The bridge or piece at the top or apex rests against and is braced by the angle portion of the standards, as well as bracing the standards. The framework thus provided is exceedingly light in construction and at the same time has great strength and rigidity, owing to the inclined bracing formation both laterally and transversely and the bridging-support at the top, which dispenses with other bracing than that had by the set of the standards and the bridge at the top.

The head formed of the cross-pieces and diagonal supports secured to the frame-pieces or standards enables light material to be used for the head, and by the arrangement of the cross arms or pieces and the diagonal supports a head-bearing of great rigidity and strength is provided, and the head is so constructed and secured in place to the side wings of the standards that the push and pull and the thrust from the movements of the swing are carried equally and uniformly, so that no strain will be had on one portion more than on another.

By my invention a light, compact, and simple frame is provided, which will be found exceedingly substantial and very durable and strong in use. A head is furnished, by which the strain and thrust in use is not on one part more than on the other, and the swing as a whole is constructed of light material, not heavy and cumbersome, and can be easily and readily handled.

The construction preferred is one having the frame or standard pieces made of a continuous piece; but it is evident such pieces could be divided at the top portion centrally, and rigidity would be had by the bridging block or piece, and while the construction and arrangement are more specially designed for portable swings it is evident that they are adapted for and can be used for swings which are anchored or set permanently in a fixed position and attain the same results of strength and rigidity and a uniform and equal distribution of the push and pull and strain. The parts are fitted accurately, so that they can be easily put together at the place for use without employment of skilled labor, as all that is required is to set up and bolt the

standards to the lower timbers or supports and bolt the block or bridge piece at the upper end and attach the cross-pieces and diagonal supports by bolting the same to the side wings of the standard or frame pieces, suspending the swing-bars from their rods and attaching the platform and seats in place between the swing-bars, which sets up the swing as a whole ready for use.

What I regard as new, and desire to secure by Letters Patent, is—

1. In a swing, the combination of two standards, each having a body of right-angle shape in cross-section bent into a yoke or U form to have side pieces or legs and a cross-piece or top, a bridge for the top of the standards, and a base for the bottom of the standards for the bridge and base to set and hold the standards at an inclination, substantially as described.

2. In a swing, the combination of two standards, each having a body of right-angle shape in cross-section bent into a yoke or U form to have side pieces or legs and a cross-piece or top, a bridge for the top of the standards, a base for the bottom of the standards, and a head supported at the upper end of the standards, substantially as described.

3. In a swing, the combination of two standards, each having a body of right-angle shape in cross-section bent into a yoke or U form to have side pieces or legs and a cross-piece or top, a transverse bridge for the top of the standards, a base for the bottom of the standards, a head supported at the upper end of the standards with its ends projected beyond the standards, and a swing-frame carried by the head, substantially as described.

4. In a swing, the combination of two standards, each having a body of right-angle shape in cross-section bent into a yoke or U form to have side pieces or legs and a cross-piece or top, a bridge for the top of the standards, a base for the bottom of the standards, and cross-arms and diagonal supports secured to the standards at the upper end and forming a head for the swing-frame, substantially as described.

5. In a swing, the combination of two standards or supports set at an inclination and transversely bridged at the top, and a head secured to the upper part of the standards or supports and consisting of cross-arms projected at each end beyond the standards or supports and diagonal supports extending from the ends of the cross-arms and across each other and attached to the standards, substantially as described.

E. K. HAYES.

Witnesses:

JOHN H. BEST,
N. F. ANDERSON.