

12 **EUROPEAN PATENT APPLICATION**

21 Application number: 90104459.4

51 Int. Cl.⁵: **H01H 83/20**

22 Date of filing: 08.03.90

30 Priority: 10.03.89 JP 58530/89
13.03.89 JP 60213/89
13.03.89 JP 60214/89

43 Date of publication of application:
12.09.90 Bulletin 90/37

84 Designated Contracting States:
CH DE FR GB IT LI

71 Applicant: MITSUBISHI DENKI KABUSHIKI
KAISHA
2-3, Marunouchi 2-chome
Chiyoda-ku Tokyo-to, 100(JP)

72 Inventor: Matsumoto, Shigeru
c/o Fukuyama Seisakusho, Mitsubishi Denki
K.K. 1-8, Midorimachi, Fukuyama-shi, 720(JP)
Inventor: Sato Eiichi
c/o Fukuyama Seisakusho, Mitsubishi Denki
K.K. 1-8, Midorimachi, Fukuyama-shi, 720(JP)
Inventor: Akiyama, Toshihiro
c/o Fukuyama Seisakusho, Mitsubishi Denki
K.K. 1-8, Midorimachi, Fukuyama-shi, 720(JP)

74 Representative: Kuhnen, Wacker & Partner
Schneggstrasse 3-5 Postfach 1553
D-8050 Freising(DE)

54 **Circuit device having circuit breaking and leakage current detecting functions.**

57 A circuit device including a leakage alarm function by incorporating in the breaker case a zero-phase current transformer for detecting a leakage current and a leakage relay for issuing leakage alarm at reception of detection signal from said zero-phase

current transformer which is mounted at a remote location from main parts of the circuit breaker of the casing. Provision is also made for a particularly advantageous arrangement of indicators and switch actuating mechanism.

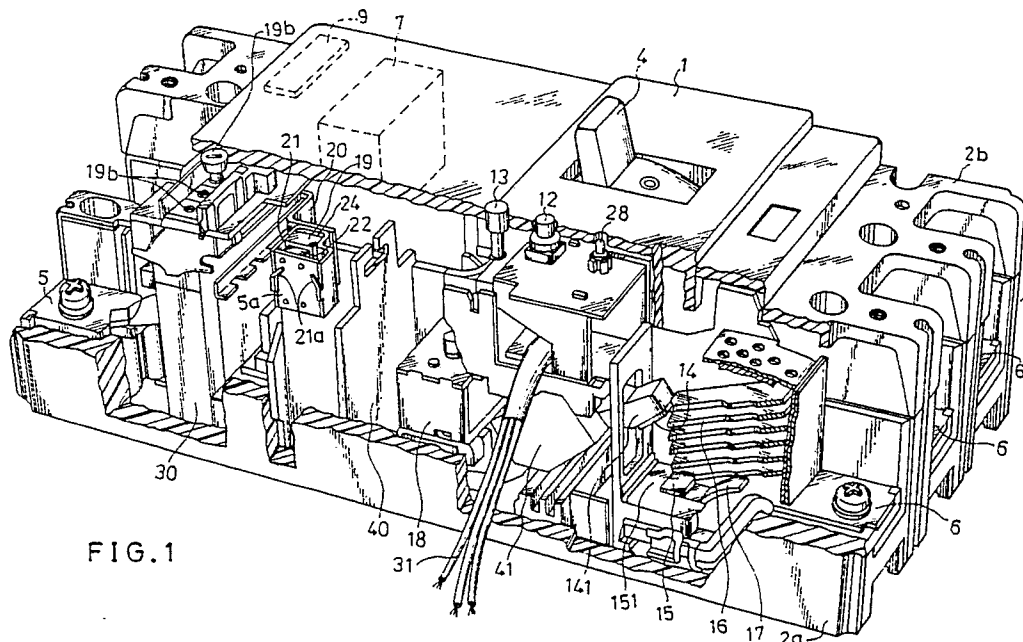

EP 0 386 768 A2

BACKGROUND OF THE INVENTION

1. Field of the Invention

The present invention relates to an improvement in a circuit device which is suitable for use in a circuit having a critical load which should not be cut off from a power source at leakage current levels not likely to result in significant damage. The present invention relates particularly to a molded case circuit breaker with provision for a leakage current alarm and having a particularly advantageous arrangement of indicators and switch actuators.

2. Description of the Related Art

Hitherto, in a power circuit in which interruption of current is not desirable, such as for a computer circuit, a circuit breaker has been used in combination with a zero-current transformer and a leakage relay. In such a combination of devices, the leakage current in the circuit is constantly monitored by the leakage relay, and in case of an occurrence of a tolerable leakage in the circuit, only a leakage alarm is issued without breaking the power circuit. Of course, the circuit breaker cuts out or interrupts the power circuit when a definite overcurrent or short circuit condition occurs.

In such conventional use of a circuit breaker combined with the zero phase current transformer and the leakage relay, there is a problem that a considerable amount of space is needed to accommodate the circuit breaker, the zero phase current transformer, and the leakage relay, since these members are provided in their individual casings. Further, bundles of interconnecting wires are needed. Also, such a system necessitates a considerable area on a switchboard for mounting, and further, mounting the combination of devices and interconnecting them necessitates considerable time, skill and labor.

SUMMARY OF THE INVENTION

The object of the present invention is to provide an improved circuit device which provides a circuit breaking function and a leakage alarm yet requires only a small mounting space in and a small mounting area on a switchboard.

The object of the present invention is achieved by a circuit device, comprising:
a casing;

5 a circuit breaker part contained in the casing and including at least a fixed contact, at least a moving contact which is movable to make and break contact with the fixed contact, a contact driving mechanism for driving the movable contact, a trip mechanism for tripping the contact driving mechanism in response to a predetermined current state such as an overload current or a short circuit condition, and a handle connected to the contact driving mechanism for manually driving the contact driving mechanism,
10 a zero-phase current transformer contained in the casing for detecting a leakage current and for generating an output signal indicative of detected leakage current, and
15 a leakage relay contained in the casing for issuing a leakage alarm signal on the basis of the output signal of the zero-phase current transformer.

In a further aspect of the invention, the leakage relay is mounted at a location in the casing sufficiently separated from a location of the circuit breaker part to isolate the leakage relay from mechanical shock or magnetic flux caused by the circuit breaker part.

25 A further technical advantage of the circuit device in accordance with the present invention is achieved by a circuit which has been set forth above and further wherein the leakage relay is mounted in a shield casing which is held by a fixing frame of magnetically soft (low coercivity) material.

A still further technical advantage of the circuit breaker in accordance with the present invention is achieved by a circuit device with a leakage current detection function which has been set forth above and further comprises:

35 a leakage current indicator for indicating detection of the leakage current by energization of the leakage relay,
40 a reset button for resetting energization state of the leakage relay, and
a test button for simulatngly forming a testing circuit thereby to check function of leakage detection operation of the leakage relay,
45 the leakage current indicator, the reset button and the test button being disposed in the neighborhood of each other and of the handle, on a face panel on a top face of the casing.

50

BRIEF DESCRIPTION OF THE DRAWINGS

FIG. 1 is a partially cut away perspective view of an embodiment of the present invention.

FIG. 1A is a perspective view of the embodiment of FIG. 1.

FIG. 2 is a circuit diagram of the embodi-

ment of FIG. 1.

FIG. 3 is an enlarged perspective view showing a mounting arrangement for a leakage relay in the embodiment of FIG. 1.

DESCRIPTION OF THE DETAILED EMBODIMENTS

Preferred embodiments in accordance with the present invention are elucidated with reference to FIG. 1 through FIG. 3.

As shown in FIG. 1, a casing 2 comprises a base part 2a and a cover part 2b. The base part 2a comprises a circuit breaker part of a known configuration including fixed contacts 15 provided on fixed conductor 151, a moving contact 14 provided on moving conductor 141, arc suppressing devices 16, a contact driving mechanism 41, a known trip mechanism 35, 36 (shown schematically in FIG. 2) for tripping the contact driving mechanism in response to an overload current state or a short circuit to break the circuit, and a handle 4 connected to the contact driving mechanism 41 for manually driving the contact driving mechanism. The base part 2a further comprises input side terminals 5 and output side terminals 6 at the input side and the load side, respectively.

The base part 2a further comprises a leakage relay 22, an amplifier 9 and a zero-phase current transformer 7. The leakage relay 22 is disposed at a location which is sufficiently removed from the location of the circuit breaker part to avoid electrical and mechanical interference from the circuit breaker part. The circuit breaker part comprises the moving contact 14 provided on the moving conductor, the fixed contact 15 provided on the fixed conductor, an arc runner 17 and the driving mechanism 41.

Furthermore, the leakage relay 22 is enclosed in a shield case 19 made of magnetically soft (low coercivity) material such as iron sheet which is formed in a ring or as a pipe of round or square shape to encircle the leakage relay 22. The shield case 19 is further mounted in a mounting frame 21 made of magnetically soft material such as iron sheet, and the mounting frame 21 is fixed to the base part 2a by a fixing frame 20 made of magnetically soft material such as iron sheet.

As shown in FIG. 1 and FIG. 3, the leakage relay 22 is mounted in the mounting frame 21, abutting on a foamed rubber pad or similarly resilient pad member 24 by fixing a printed circuit substrate 5a to close the front opening of the mounting frame 21 and bending a pair of pins 21a, 21a to hold the face of the printed circuit substrate 5a.

As a result of the above-mentioned disposition

and mounting of the leakage relay 22, mechanical vibration or shock of the driving mechanism 41 and trip mechanism (shown schematically in FIG. 2) does not have a substantial adverse effect on the function of the leakage relay 22. Furthermore, the magnetic flux of the current flowing through the moving conductor 141 and fixed conductor 151 also does not adversely affect the function of the leakage relay 22. That is, by selecting the disposition of the leakage relay 22 apart from the circuit breaker part and mounting it in the shield case 19 and the mounting frame 21 and by constructing the fixing frame 20 made of magnetically soft materials, the mechanical and magnetical causes of chattering of the leakage relay 22 are substantially removed, thereby assuring stable functioning and operation of leakage relay 22.

The arrangement shown also includes a barrier 40. This barrier 40, together with associated structure of the bottom part 2a and cover part 2b, defines two internal compartments. The front internal compartment contains the leakage relay 22 and associated components. The rear compartment contains the circuit breaker part. The rear compartment is dimensioned to be small enough that hot gases generated during a breaking operation are effectively exhausted, yet not so small that the compartment will explode. The front compartment serves to isolate the leakage relay 22 and associated components from exposure to the exhaust gases generated by breaking operations.

The circuit device according to the present invention is integrated into an electrical power distribution system as shown in FIG. 2. The amplifier 9 derives power directly from the system power source 50 through the input side 5, lines 32, and lines 33. The zero-phase current transformer 7, which is inductively coupled to the conductors 32, produces an output signal when the vector sum of the currents passing through the conductors 32 does not cancel. Each conductor 32 then connects with its associated overcurrent detector 35, and an associated short circuit detector 36, both of conventional design. The current then passes out of the circuit device through the load side 6 to a load or the system.

Usually the lid or cover of the switchboard has windows for each handle, wherein the size of the window is just large enough to expose a handle flange cover 1. As shown in FIG. 1, however, the cover part 2b in a preferred embodiment of the present invention has a handle flange cover 1 having a square hole 49 providing access to the handle 4. A leakage indication lamp 28 is also viewable through a hole in the handle flange cover 1 positioned near the handle 4. A reset button 12 and a test button 13 also protrude through holes in the handle flange cover 1 near the handle 4 and the

leakage indication lamp 28.

Since all the three members, namely the leakage indication lamp 28, the reset button 12 and the test button 13, are provided in the vicinity of the handle 4 on the same handle flange cover 1, only one window for the handle flange cover 1 is sufficient to provide access to the handle 4 as well as the leakage indication lamp 28, the reset button 12 and the test button 13. Therefore there is no need to bore three additional holes to expose the leakage indication lamp 28, and to provide access to the reset button 12 and the test button 13 on the lid or cover of the switchboard.

The operation of the invention is as follows.

When a leakage in the circuit connected to the load side terminals 5 takes place, the zero-phase current transformer 7 detects the leakage current. The output signal of the zero-phase current transformer 7 is amplified by the amplifier 9 to provide an amplified signal. The amplified signal drives the leakage relay 22, which issues an alarm signal through the leakage alarm output lines 31, to an alarm 39 as shown schematically in FIG. 2. At the same time the leakage indication lamp or LED 28 lights to indicate the existence of leakage. The leakage relay 22 and the leakage indication lamp 28 are latched or held in the leakage detection state by means of known latching circuitry. The latched leakage state of the leakage relay 22 and the leakage indication lamp 28 are reset by pushing the reset button 12.

In order to check the leakage alarm function of this circuit breaker, the test button may be pushed. Then, by known test circuit configuration, the leakage state is simulated to check the function of the leakage relay, the leakage indication lamp, and associated circuitry.

Although the invention has been described in terms of a particular preferred form, it is understood that details of construction and the combination and arrangement of parts may be resorted to without departing from the spirit and the scope of the invention as hereinafter claimed.

Claims

1. A circuit device, comprising:
 a casing;
 a circuit breaker part contained in said casing and including at least a fixed contact, at least a moving contact which is movable to make and break contact with said fixed contact, a contact driving mechanism for driving said movable contact, a trip mechanism for tripping said contact driving mechanism in response to a predetermined current state and a handle connected to the contact driving mechanism for manually driving the contact driving

mechanism;

a zero-phase current transformer contained in said casing, for detecting a leakage current as output signal thereof; and

a leakage relay contained in said casing for issuing a leakage alarm signal on the basis of said output signal of said zero-phase current transformer.

2. A circuit device in accordance with claim 1, which further comprises:

a leakage current indicator for indicating detection of said leakage current by energization of said leakage relay;

a reset button for resetting said leakage relay; and a test button for simulating a leakage state thereby to check the function of leakage detection operation of said leakage relay;

said leakage current indicator, said reset button and said test button being disposed in mutual proximity and in proximity to said handle, on a flange cover on a top face of said casing.

3. A circuit device in accordance with claim 1, wherein said leakage relay is mounted in a shield casing which is held by a fixing frame of magnetically soft material.

4. A circuit device in accordance with claim 1 wherein said leakage relay being mounted at a location in said casing in a corner part which is sufficiently separated from said circuit breaker part to prevent mechanical shock or magnetic flux generated by said circuit breaker part from interfering with operation of said leakage relay.

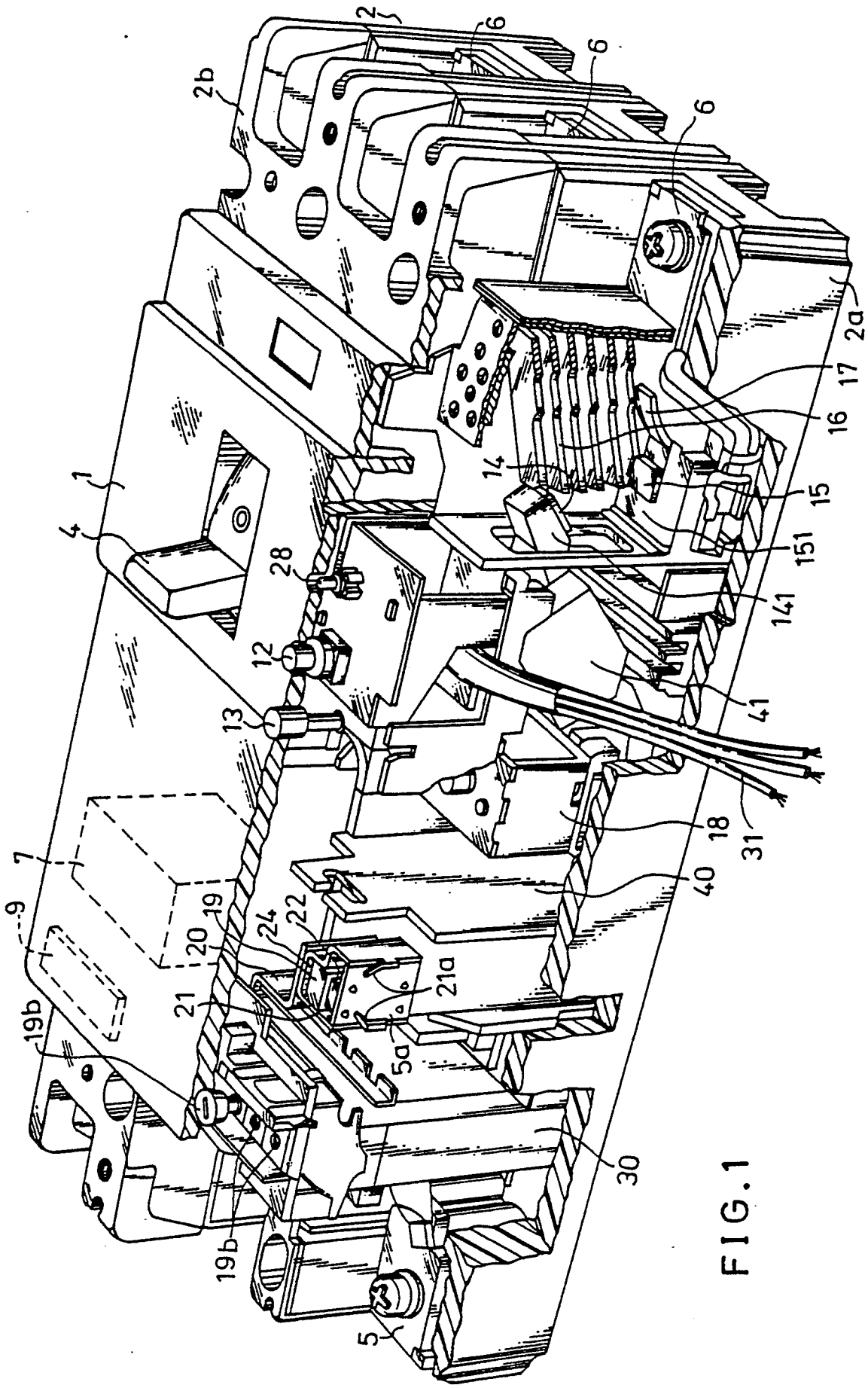

FIG. 1

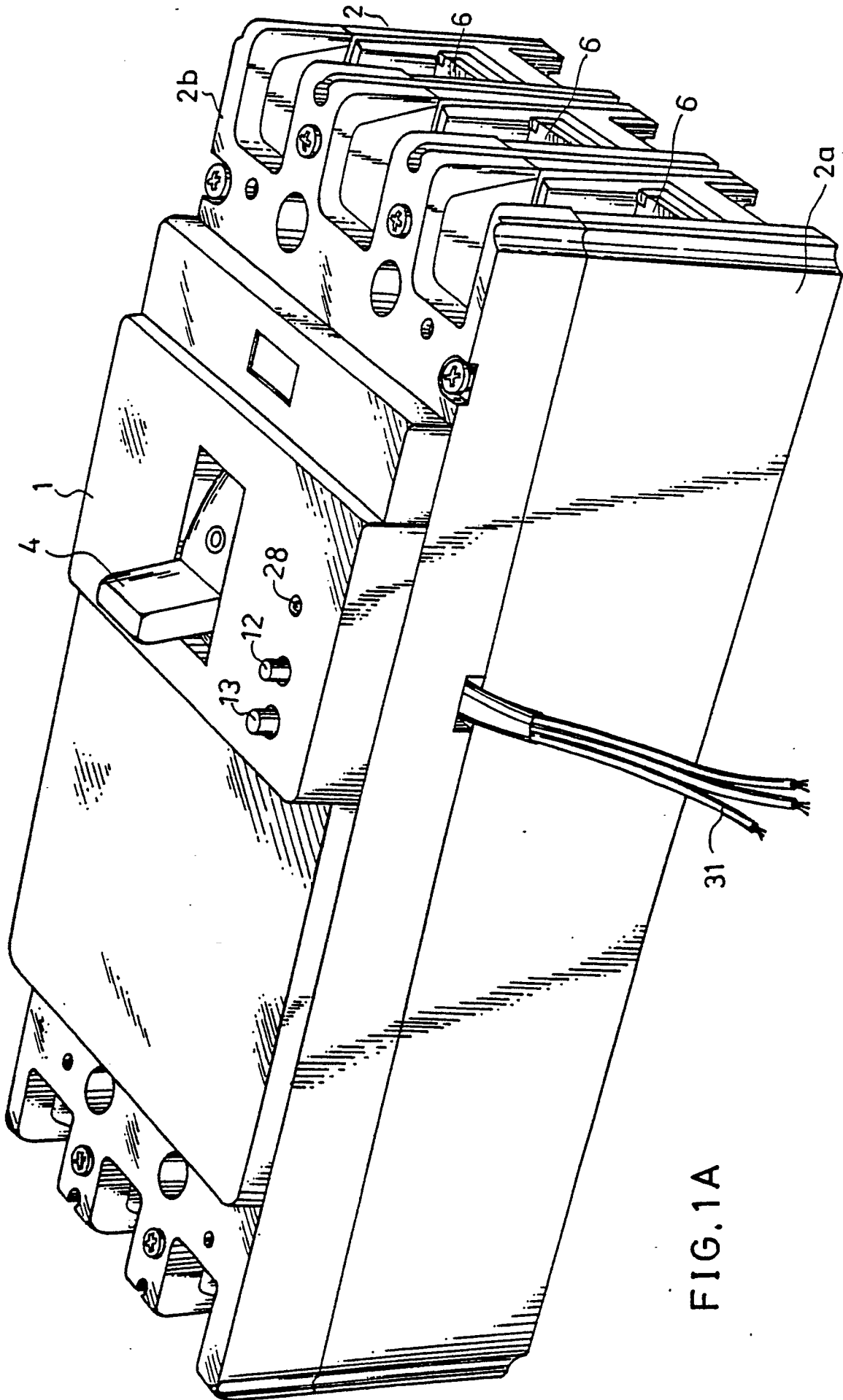

FIG. 1A

FIG. 2

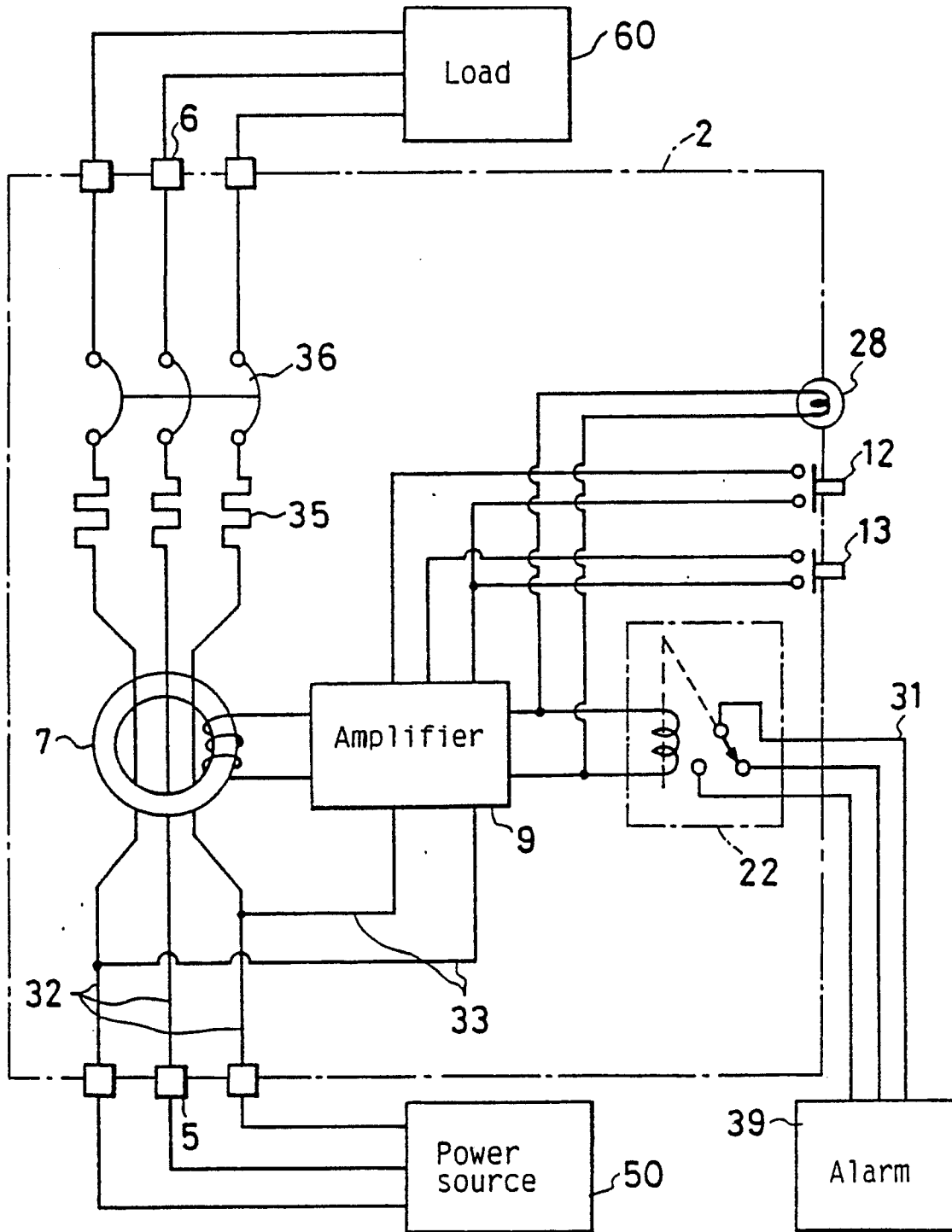

FIG. 3

