



INTERNATIONAL APPLICATION PUBLISHED UNDER THE PATENT COOPERATION TREATY (PCT)

<p>(51) International Patent Classification ⁵ : E05D 15/10</p>	<p>A1</p>	<p>(11) International Publication Number: WO 93/18261 (43) International Publication Date: 16 September 1993 (16.09.93)</p>
<p>(21) International Application Number: PCT/NO93/00041 (22) International Filing Date: 12 March 1993 (12.03.93) (30) Priority data: 920988 13 March 1992 (13.03.92) NO (71) Applicant (for all designated States except US): A/S GRO-RUD JERNVAREFABRIK [NO/NO]; Østre Aker vei 243, N-0977 Oslo (NO). (72) Inventor; and (75) Inventor/Applicant (for US only) : STRANDENGÉN, Einar [NO/NO]; Hestehagen 17, N-0956 Oslo (NO). (74) Agent: LANGFELDT, Jens, F., C.; Bryns Patentkontor A/S, P.O. Box 765, Sentrum, N-0106 Oslo (NO).</p>		<p>(81) Designated States: AT, AU, BB, BG, BR, CA, CH, CZ, DE, DK, ES, FI, GB, HU, JP, KP, KR, LK, LU, MG, MN, MW, NL, NO, NZ, PL, PT, RO, RU, SD, SE, SK, UA, US, VN, European patent (AT, BE, CH, DE, DK, ES, FR, GB, GR, IE, IT, LU, MC, NL, PT, SE), OAPI patent (BF, BJ, CF, CG, CI, CM, GA, GN, ML, MR, SN, TD, TG).</p> <p>Published With international search report. In English translation (filed in Norwegian).</p>
<p>(54) Title: SLIDING DOOR ARRANGEMENT</p>		
<p>(57) Abstract</p> <p>An arrangement for a sliding door, where the frame (19) of the sliding door has an upper sliding rail (1) and a lower sliding rail (2) for the sliding door, and where the sliding door has two vertically disposed sliding door fittings, where each fitting has an upper guide (3) which partly engages with the upper sliding rail (1) and a lower guide (4) which partly engages with the lower sliding rail (2), said lower guide (4) having a caster (6) which can roll along the back (2') of the lower sliding rail and where said upper and lower guides are connected to one another via a mechanism (10, 11, 16) which operates the position of the sliding door fitting. In the operational position of the sliding door said upper and lower guides (3, 4) are lying vertically. On manipulating the sliding door fitting to the locked position the guides (3, 4) come to lie at an inclination relative to the vertical, said sliding door on the transverse rotational turning to the locked position forming a sealing abutment with the frame (19) of the sliding door.</p>		

FOR THE PURPOSES OF INFORMATION ONLY

Codes used to identify States party to the PCT on the front pages of pamphlets publishing international applications under the PCT.

AT	Austria	FR	France	MR	Mauritania
AU	Australia	GA	Gabon	MW	Malawi
BB	Barbados	GB	United Kingdom	NL	Netherlands
BE	Belgium	GN	Guinea	NO	Norway
BF	Burkina Faso	GR	Greece	NZ	New Zealand
BG	Bulgaria	HU	Hungary	PL	Poland
BJ	Benin	IE	Ireland	PT	Portugal
BR	Brazil	IT	Italy	RO	Romania
CA	Canada	JP	Japan	RU	Russian Federation
CF	Central African Republic	KP	Democratic People's Republic of Korea	SD	Sudan
CG	Congo	KR	Republic of Korea	SE	Sweden
CH	Switzerland	KZ	Kazakhstan	SK	Slovak Republic
CI	Côte d'Ivoire	LI	Liechtenstein	SN	Senegal
CM	Cameroon	LK	Sri Lanka	SU	Soviet Union
CS	Czechoslovakia	LU	Luxembourg	TD	Chad
CZ	Czech Republic	MC	Monaco	TG	Togo
DE	Germany	MG	Madagascar	UA	Ukraine
DK	Denmark	ML	Mali	US	United States of America
ES	Spain	MN	Mongolia	VN	Viet Nam
FI	Finland				

SLIDING DOOR ARRANGEMENT

The present invention relates to an arrangement for sliding doors, where the frame of the sliding door has an upper sliding rail and a lower sliding rail for the sliding door, and where
5 the sliding door has two vertically disposed sliding door fittings, where each fitting has an upper guide which partly engages with the upper sliding rail, and a lower guide which partly engages with the lower sliding rail, said lower guide having a caster which can roll along the back of the lower
10 sliding rail, and where said upper and lower guides are connected to one another via a mechanism which operates the position of the sliding door fitting.

The purpose of the present invention is to depart from such
15 raising and lowering of the sliding door, namely in that instead the sliding door is caused to move transversely between the operational position and the locked position. Thus an enhanced sealing abutment is achieved, and there is no possibility of the sliding door being lifted from the outside
20 by means of e.g. a crowbar, hand jack, or similar.

Moreover, the present invention aims to provide an arrangement where the forces required to operate the position of the fitting of the sliding door will not be as great as those
25 normally needed, as there will no longer be a need to raise and lower a sliding door which may be very heavy because it contains large panes of glass.

According to the invention, the arrangement is characterized
30 in that in the operational position of the sliding door a first portion of said upper and lower guides is lying vertically, and that said first guide portions will, on manipulation of the door fitting to locked position, come to lie at an inclination relative to the vertical, the sliding door on its transverse
35 turning movement to the locked position forming a sealing abutment with the frame of the sliding door.

According to further embodiments of the arrangement, a first profile portion of each of said sliding rails which engages with said guides has a greater cross-section than the remaining second profile portion of the sliding rail. Each guide consists of said first portion which has a recess that engages with said first profile portion of the sliding rail and a second portion which is rigidly connected to the first portion via a shaft which is located in the frame or the door leaf of the sliding door, the actuating mechanism having at each end a guide plate which interacts with a pin on the free end of the second portion of the guide, and said guide plate having a groove which has a vertical portion and a portion which forms an angle with the vertical. In a first end position between said groove and pin, the sliding door is in locking position and in a second end position the sliding door is in operational position.

Said actuating mechanism has at least one locking pin which projects from the vertical end edge of the door frame or the door leaf, and which on movement of the mechanism and the simultaneous transverse movement of the sliding door is brought into engagement and out of engagement, respectively, with a strike plate in the frame of the sliding door.

The invention will now be described in more detail in the following specification with reference to the attached drawings.

Fig. 1 illustrates the arrangement according to the invention where the sliding door is in the operational position.

Fig. 2 illustrates the arrangement according to the invention where the sliding door is in the locked position.

Fig. 3 illustrates a section through the arrangement as shown in figure 2.

Figs. 4 and 5 show the arrangement, according to the invention, seen from above in the operational position and the locked

position, respectively.

In fig. 1 the arrangement is shown with two sliding rails 1, 2 at the top and the bottom, respectively, of the frame of the sliding door. The arrangement has an upper rail guide 3 and a lower rail guide 4, where said guides 3, 4 engage partly with a first profile portion 1' and 2', respectively of said upper and lower sliding rails 1 and 2. The upper guide 3 has a recess 3' and the lower guide 4 has a recess 4', said recesses engaging respectively with said first profile portion of the adjacent sliding rails 1 and 2. The lower rail guide has in addition a caster 5 which is rotatably arranged on the lower guide via a shaft 6. The upper rail guide 3 consists of a first portion 3'' and a second portion 3'''. Said two portions are rigidly connected to one another via a common shaft 7 which is located in the frame or door leaf 8 of the sliding door. In a similar way the lower rail guide is also provided with a first portion 4'' and a second portion 4''' and where these two portions are rigidly connected to one another via a shaft 9 which is located in the frame or door leaf of the sliding door. The actuating mechanism has, at each end, a guide plate or ram slide 10, 11, at the top and bottom, respectively. Said guide plate interacts with a pin 12 which is equipped with caster 12' for the upper rail guide and in a similar way with a pin 13 equipped with a caster 13' for the lower rail guide.

As can be seen from figures 1 and 2, respectively, said guide plate or ram slide 10, 11 has a groove 14, 15, respectively, for guiding said respective pin with caster 12, 12' and 13, 13', respectively, said groove 14, 15 having a vertical portion and a portion that forms an angle with the vertical.

To connect said guide plates or ram slides 10, 11, a connector rail 16 is positioned therebetween.

The actuating mechanism is preferably at least at one end of the sliding door, i.e., in one of the two fittings of the sliding door, provided with at least one locking pin 17 which is placed in the connector rail 16, preferably by means of

riveting or by welding. When the actuating mechanism is moved from the position shown in figure 1 to the position shown in figure 2, the locking pin or locking rivet 17 will move into the recess 18' in a strike plate 18 which is located in the frame 19 of the sliding door. In the locked position of the sliding door, as is shown in figure 2, the locking pin or rivet 17 will engage with the narrower portion 18'' of the opening 18' in the strike plate 18, thereby preventing the sliding door from being moved in that it is physically locked to the door frame. Since said first and second portions of the respective rail guides 3 and 4 form an angle with one another and because of the respective form of the grooves 14, 15 in the guide plates or ram slides 10, 11, the sliding door, as a result of the rotation of the rail guides 3, 4, will not be lowered when being locked, as happens in the prior art, but will be displaced sideways with a light turning movement to a sealing abutment with the door frame 19 via a seal 20.

It will be understood immediately that the two shafts 7 and 9 run the full length of the sliding doors so that the fittings at each end of the sliding door are actuated evenly and simultaneously. In order to ensure a stable movement of the shafts 7 and 9, they should be mounted on two or more bearings 7' and 9', respectively, of which only one is shown for each shaft 7, 9.

In order to delimit the front portion of the fitting, a front edge rail 21, for example, can be provided. By means of an expedient design, said front edge rail can optionally extend along the full height of the door leaf.

In order to connect the first portion of the rail guide to the corresponding shaft, the shaft is provided with a recess 7'' and 9'', respectively, said first portion of the guide having a corresponding recess so that it forms a direct engagement with the shaft. In a corresponding way, the second portion of the guide also has a recess which is such that it engages directly with the shaft. In order to lock the shaft against longitudinal movement in one direction or another, the second

end of the guide is provided with a set screw or a locking pin which forms engagement between the shaft and the second end of the guide. Said set screw or locking pin is denoted by means of the reference numerals 22 and 23, respectively, in figure 3.

5 In figure 4, the arrangement according to the invention is seen from above, where the sliding door is in the operational position, whilst figure 5 depicts the door in the locked position. In order to keep the figures as simple as possible, the door frame has not been drawn in on these two figures. The
10 same reference numerals are used in figures 4 and 5 as were used in figures 1 to 3. A more detailed explanation of these two figures 4 and 5 is therefore considered to be superfluous. For the record, it is pointed out that the sliding rail 1 has
15 not been drawn in on figures 4 and 5 for reasons of clarity.

Even though it is not shown in the drawings, it will be understood immediately that the inner rail 16 should be
20 considered as an espagnolette inner rail which interacts with a known mechanism per se in order to move the inner rail either up or down via a twist handle and a gear. A mechanism of this kind is considered as belonging to the state of the art and thus does not need any further explanation.

25

30

35

C L A I M S

1.

An arrangement for a sliding door, where the frame of the sliding door has an upper sliding rail and a lower sliding rail for the sliding door, and where the sliding door has two vertically disposed sliding door fittings, where each fitting has an upper guide which partly engages with the upper sliding rail and a lower guide which partly engages with the lower sliding rail, said lower guide having a caster which can roll along the back of the lower sliding rail, and where said upper and lower guides are connected to one another via a mechanism which operates the position of the sliding door fitting, characterized in that in the operational position of the sliding door, a first portion of said upper and lower guides is lying vertically, and that said first guide portions, on manipulating the sliding door fitting to locked position, come to lie at an inclination relative to the vertical, said sliding door on its transverse turning movement to the locked position forming a sealing abutment with the frame of the sliding door.

2.

An arrangement as disclosed in claim 1, characterized in that a first profile portion of each of said sliding rails which comes into engagement with said guides has a larger cross-section than the remaining second profile portion of the sliding rail.

3.

An arrangement as disclosed in claim 1 or claim 2, characterized in that each guide consists of said first portion which has a recess which engages with said first profile portion of the sliding rail and a second portion that is rigidly connected to the first portion via a shaft which is located in the sliding door frame or the sliding door leaf, said actuating mechanism having at each end a guide plate which

interacts with a pin on the free end of the second portion of the guide, and said guide plate having a groove which has a vertical portion and a portion that forms an angle with the vertical.

5 4.

An arrangement as disclosed in claim 3, characterized in that in a first end position between said groove and pin, the sliding door is in the locked position and in a second end position the sliding door is in the operational position.

10

5.

An arrangement as disclosed in one or more of the preceding claims, characterized in that the actuating mechanism has at least one locking pin which projects from the vertical end edge of the door frame or the door leaf, and which, on the movement of the mechanism and the simultaneous movement of the sliding door, is brought into engagement and out of engagement, respectively, with a strike plate in the frame of the sliding door.

20

25

30

35

1/2

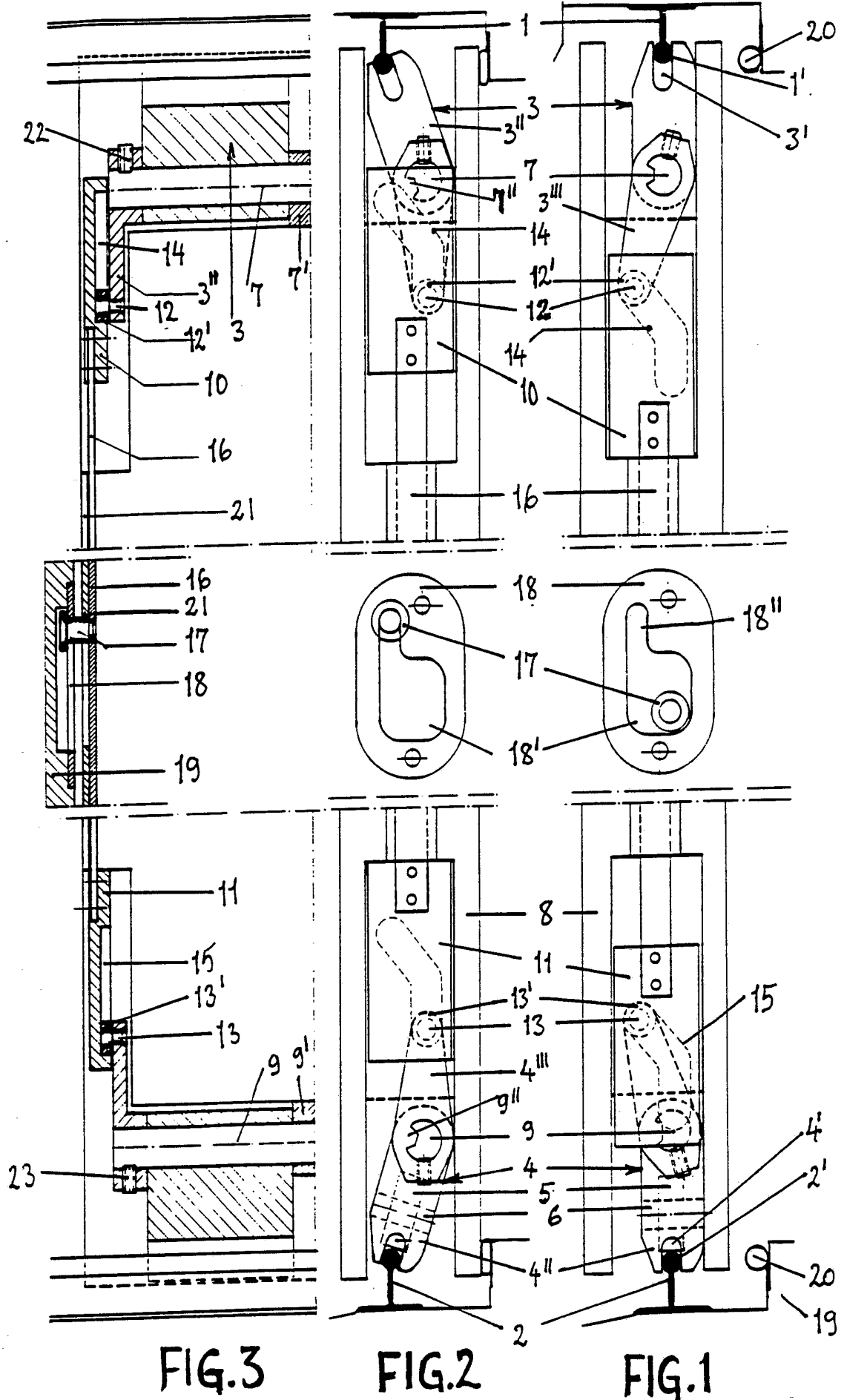

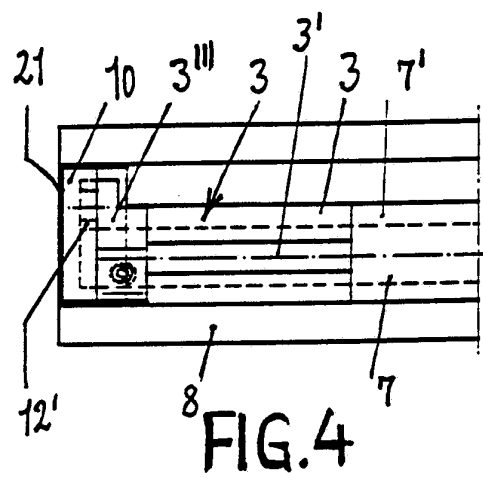
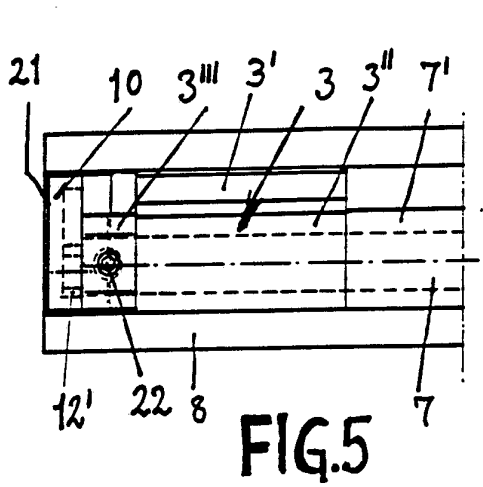

INTERNATIONAL SEARCH REPORT

International application No.

PCT/NO 93/00041

A. CLASSIFICATION OF SUBJECT MATTER		
IPC5: E05D 15/10 According to International Patent Classification (IPC) or to both national classification and IPC		
B. FIELDS SEARCHED		
Minimum documentation searched (classification system followed by classification symbols)		
IPC5: E05D		
Documentation searched other than minimum documentation to the extent that such documents are included in the fields searched		
SE,DK,FI,NO classes as above		
Electronic data base consulted during the international search (name of data base and, where practicable, search terms used)		
C. DOCUMENTS CONSIDERED TO BE RELEVANT		
Category*	Citation of document, with indication, where appropriate, of the relevant passages	Relevant to claim No.
X	US, A, 2570563 (R. KREIMENDAHL), 9 October 1951 (09.10.51)	1
Y	--	2-5
X	US, A, 2774998 (F.W. KIKERT), 25 December 1956 (25.12.56)	1
Y	--	2-5
X	US, A, 2199182 (D.C.E. LEONARD), 30 April 1940 (30.04.40)	1
Y	--	2-5
<input checked="" type="checkbox"/> Further documents are listed in the continuation of Box C. <input checked="" type="checkbox"/> See patent family annex.		
* Special categories of cited documents: "A" document defining the general state of the art which is not considered to be of particular relevance "E" earlier document but published on or after the international filing date "L" document which may throw doubts on priority claim(s) or which is cited to establish the publication date of another citation or other special reason (as specified) "O" document referring to an oral disclosure, use, exhibition or other means "P" document published prior to the international filing date but later than the priority date claimed "T" later document published after the international filing date or priority date and not in conflict with the application but cited to understand the principle or theory underlying the invention "X" document of particular relevance: the claimed invention cannot be considered novel or cannot be considered to involve an inventive step when the document is taken alone "Y" document of particular relevance: the claimed invention cannot be considered to involve an inventive step when the document is combined with one or more other such documents, such combination being obvious to a person skilled in the art "&" document member of the same patent family		
Date of the actual completion of the international search		Date of mailing of the international search report
8 June 1993		10 -06- 1993
Name and mailing address of the ISA/ Swedish Patent Office Box 5055, S-102 42 STOCKHOLM Facsimile No. +46 8 666 02 86		Authorized officer Christer Wendenius Telephone No. +46 8 782 25 00

INTERNATIONAL SEARCH REPORT

International application No.

PCT/NO 93/00041

C (Continuation). DOCUMENTS CONSIDERED TO BE RELEVANT		
Category*	Citation of document, with indication, where appropriate, of the relevant passages	Relevant to claim No.
Y	DE, C2, 2941109 (STRAUB, T.), 4 August 1983 (04.08.83), column 5, line 7 - line 28, figure 4 --	2-4
Y	DE, A1, 2536089 (GRETSCH-UNITAS GMBH BAUBESCHLAGFABRIK), 17 February 1977 (17.02.77), figures 7-10 -----	4-5

INTERNATIONAL SEARCH REPORT
Information on patent family members

30/04/93

International application No.
PCT/NO 93/00041

Patent document cited in search report	Publication date	Patent family member(s)	Publication date
US-A- 2570563	09/10/51	NONE	
US-A- 2774998	25/12/56	BE-A- 496663 FR-A- 1029605 NL-C- 78444 NL-B- 156516	00/00/00 00/00/00 00/00/00 00/00/00
US-A- 2199182	30/04/40	NONE	
DE-C2- 2941109	04/08/83	AT-T- 3571 EP-A,B- 0027261 SE-T3- 0027261	15/06/83 22/04/81
DE-A1- 2536089	17/02/77	AT-B- 364272 BE-A- 845118 CH-A- 599441 FR-A,B- 2321030 NL-A- 7608955	12/10/81 01/12/76 31/05/78 11/03/77 15/02/77