

No. 770,838.

PATENTED SEPT. 27, 1904.

H. N. WHITTELSEY.
VESSEL HULL.

APPLICATION FILED SEPT. 11, 1903.

NO MODEL.

3 SHEETS—SHEET 1

Fig. 1.

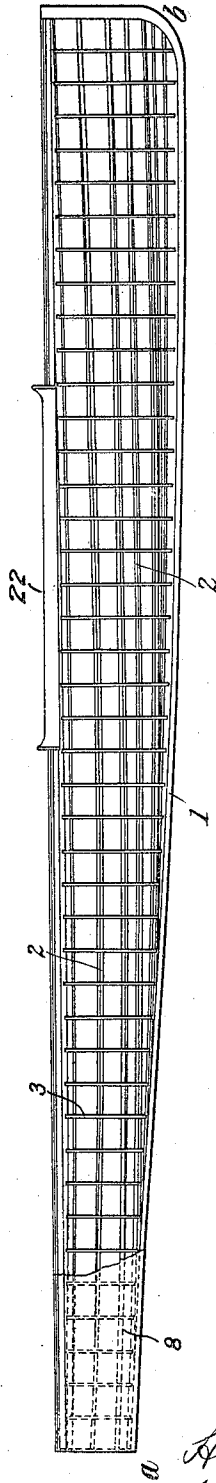

Witnesses:
John J. Holup
Geo. Robt. Taylor

Inventor:
Henry Newton Whittelsey
by *Wm. W. W. W. W. W.* Att'ys.

No. 770,838.

PATENTED SEPT. 27, 1904.

H. N. WHITTELSEY.
VESSEL HULL.

APPLICATION FILED SEPT. 11, 1903.

NO MODEL.

3 SHEETS—SHEET 2.

Fig. 2.

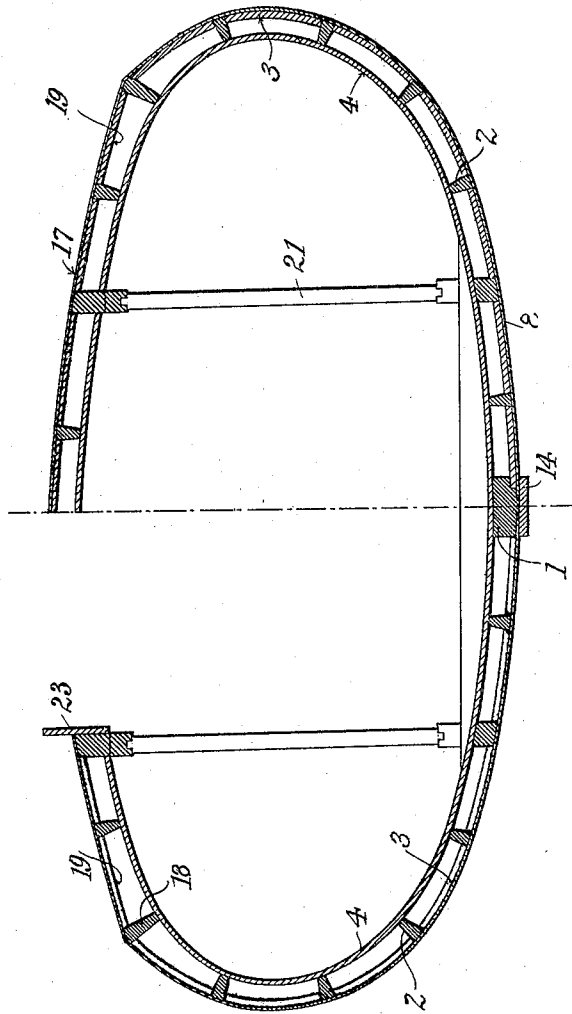

Witnesses:
John H. Pritch
Geo Robt Saylor

Inventor:
Henry Newton Whitelsey
by *Wm Wm Atty's.*

No. 770,838.

PATENTED SEPT. 27, 1904.

H. N. WHITTELSSEY.
VESSEL HULL.

APPLICATION FILED SEPT. 11, 1903.

NO MODEL.

3 SHEETS—SHEET 3.

Fig. 3.

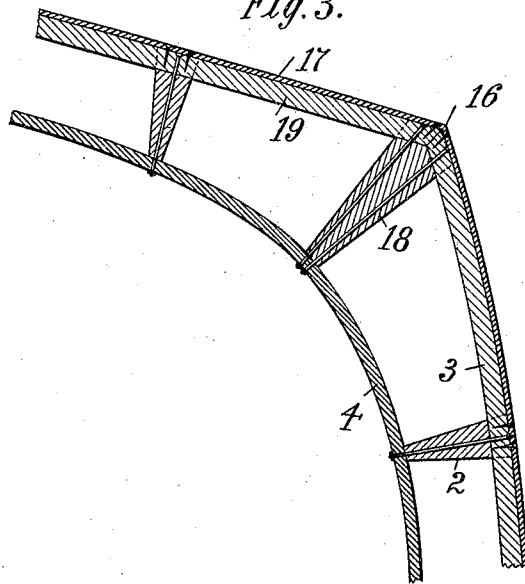

Fig. 4.

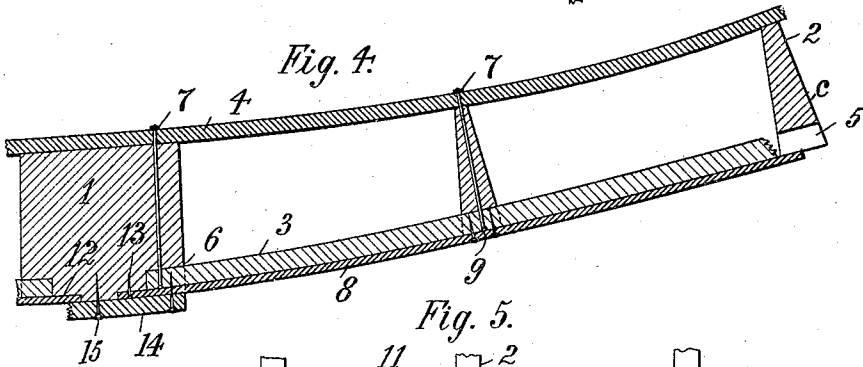
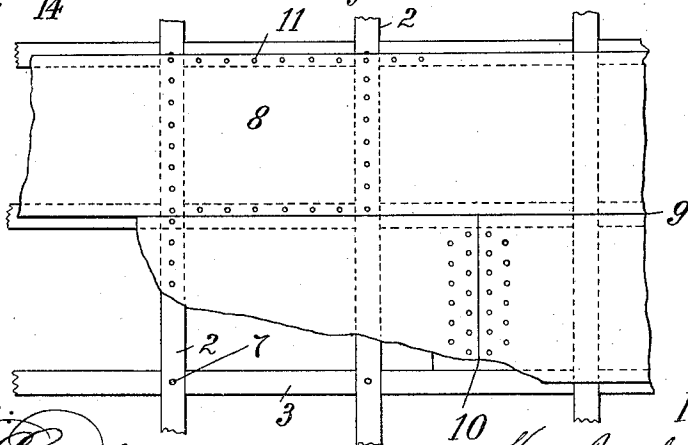

Fig. 5.



Witnesses:
John Patsch
Geo. Robt Taylor

Inventor:
Henry Newton Whittelsey
 by *D. J. ...* Attys.

UNITED STATES PATENT OFFICE.

HENRY NEWTON WHITTELTSEY, OF NEW YORK, N. Y.

VESSEL-HULL.

SPECIFICATION forming part of Letters Patent No. 770,838, dated September 27, 1904.

Application filed September 11, 1903. Serial No. 172,716. (No model.)

To all whom it may concern:

Be it known that I, HENRY NEWTON WHITTELTSEY, a citizen of the United States, residing in the borough of Richmond, city of New York, State of New York, have invented a certain new and useful Improvement in Vessel-Hulls, of which the following is a description.

In the construction of vessel-hulls built of wood it has heretofore been the custom to construct the framing of solid bent or sawed timbers with the outside planking or skin fastened to the same. This has been rendered water-tight by calking the plank edges, which necessitates that the plank must be of a certain minimum thickness. In vessels in which it has been necessary to reduce the weight two thicknesses of much thinner planking have been used, a construction which does not require calking. The tendency in very light vessels constructed in this manner is to wring, and such vessels also have a general lack of stiffness and inability to resist strains.

It is the object of my invention to produce a single-planked wood hull which has all the essential strength and water-tightness of the ordinary construction and with the lightness of the double-plank method, but with much greater rigidity than such method will permit. A further object of the invention is to reduce the amount of labor required as compared with other special forms of light construction.

Briefly stated, the invention comprises outside wooden frames of the molded transverse shape of the vessel and to which are fastened the outside planking or skin. Connecting the outside frames are longitudinal members, which preferably extend the entire length of the vessel and may be secured to the stem and stern post or transom. Connecting the longitudinal members are inner frames which correspond to and are arranged parallel with the outer frames. These inside frames are preferably continuous—that is, they pass under the deck, around the sides of the vessel, and over the keel. In connection with the

outside frames suitable deck frames or carlines are used for supporting the deck, and other longitudinal members extend under the deck and are arranged similarly to those on the side. The frames and carlines are thoroughly tied to the longitudinal members by means of suitable rivets. The outside frames and deck-carlines are so notched in the longitudinal members as to make the outside of the framework flush. This construction produces a series of sections, each formed of two longitudinal members and an inner and outside frame. The planking is made the same width as these sections and extends from center to center of contiguous longitudinal members. The plank edges are fastened to the longitudinal members by fastenings spaced sufficiently close together to make a water-tight joint. This is possible owing to the location of the longitudinal members behind the seam. The planks are also secured to the outside frames by suitable fastenings. By fastening the planks transversely to the outside frames and longitudinally along the plank edges upon the longitudinal members the plank is supported by a system of fastenings arranged in the form of comparatively small squares. This supporting feature allows a very thin outside planking to be used.

In order to better understand the nature of the invention, attention is directed to the accompanying drawings, which form one embodiment of my invention.

Figure 1 represents a side view of the frame of a vessel; Fig. 2, a section thereof, somewhat enlarged; Fig. 3, a section of the gunwale construction, somewhat enlarged; Fig. 4, a section of the keel and lower part of the frame, and Fig. 5 a side view of part of the planking and frame.

In all the several views like parts are indicated by the same numerals and letters of reference.

The frame of the vessel is composed of a keel, as 1, to which are attached the stem *b* and the stern-post or transom *a* in any well-known manner. Running fore and aft and spaced at

intervals around the entire hull are longitudinal members 2, which are preferably as wide as the keel is deep. Suitable outside frames 3, which may be continuous from one side of the keel to the other, but in the illustration extend from the keel to the gunwale only, are secured to the outside edges of the longitudinal members, and continuous inside frames 4 are secured to the inner edges of the longitudinal members. The inside frames are shown as extending entirely around the inside of the hull and are made each in a single piece; but this is not essential, as they may be non-continuous and made in several pieces.

The outside frames 3 are preferably mortised or notched into the longitudinal members, as shown at 5, and their lower ends may rest in notches 6 within the keel, so as to make a smooth outside surface for the attachment of the plank. The inside and outside frames are secured to the longitudinal members and the whole framework strongly tied together, preferably by means of through-fastenings, which may consist of rivets.

The plank or skin 8, which covers the sides and deck, is formed in pieces as wide as the space which separates the center line of adjoining longitudinal members. The plank edges 9 are arranged along the middle of the outer faces of the longitudinal members, while butts, if any be required, are located between the outside frames, as at 10. Suitable fastenings 11—such as screws, nails, or rivets—secure the plank to the outside frames and longitudinal members, thus supporting the plank by a system of comparatively small squares. The fastenings 11 are spaced sufficiently close to draw the edges of the plank against the longitudinal members, and thereby form a watertight joint, thus avoiding the necessity of calking the seam.

For the purpose of reducing weight and to give a large bearing-surface for the edges of the plank the longitudinal members may be tapered in cross-section, as at *c*, Fig. 4. The keel may be rabbeted at 12 to form a surface for the lowermost plank, which may be secured in place by additional fastenings 13, driven into the keel. A false keel or chafing-piece 14 may be applied after the plank has been placed in position and secured by fastenings, as at 15, driven into the keel or into the plank and lower extremities of the outside frames.

In order to produce a more or less level deck 17, which can be walked upon and at the same time allow the inner frames 4 to be continuous, the structure illustrated in Figs. 2 and 3 may be employed. The outer frames 3 in this case are not continuous, but end at the gunwale, as at 16, where they join the deck beams or carlines 19, where the sides

and deck form an obtuse angle. The inner frames are continuous, as shown, and are bent around in the form of a curve of sufficiently large radius to avoid injury to the fiber of the wood. In order to admit of the greater separating interval between the inner and outer frames at this point necessitated by the design, the longitudinal member immediately adjacent thereto may be somewhat wider than the others, as shown at 18. This longitudinal member should also be sufficiently thick so that it may take the double fastenings required for the ends of the frames 3 and 19.

If it is desired, for the purpose of giving additional strength to the structure vertical stanchions 21 may be arranged at intervals to connect the top and bottom of the frame. One or more cockpits 22, having coamings 23, may be arranged in any suitable manner, and the necessary engine-foundations and other structures may be built within the boat.

It will be noted that the arrangement of the outside frame and the inside frame with the longitudinal members between forms a truss, which mechanically is the strongest arrangement for stiffness for a given amount of material. It is also to be noted that by the arrangement of securing the plank to the frames in comparatively small squares a skin of very light thickness may be used, and owing to the longitudinal members this skin does not have to be calked. It has been found in practice that a skin of about one-third the thickness of that used in the ordinary single-plank construction or about the same thickness as one layer of plank in double-plank construction may be used. It is also to be noted that by means of the arrangement of inner and outer frames and longitudinal separating members riveted at short intervals all the members are brought into tension, which members in tension almost entirely absorb the vibrations of the machinery from a practical standpoint.

What I claim is—

1. In a vessel-hull, the combination with longitudinal members, outside frames and inner frames, said outside frames being substantially flush with the outer edges of the longitudinal members, of planking of substantially the same width as the spacing of the longitudinal members and fastened along its abutting edges to such longitudinal members, substantially as described.

2. In a vessel-hull, the combination of the keel outside frames secured thereto on each side thereof, continuous inner frames passing over the keel, longitudinal members between the frames, and planking the same width as the spacing of the longitudinal members fastened along its abutting edges to said longitudinal members, substantially as described.

3. In a vessel-hull, the combination of lon-

5 longitudinal members, continuous inner frames curving from the sides to the deck, outside frames and deck-carlines meeting at an angle at the gunwale, and a longitudinal member supporting the joints and of greater depth than those immediately above and below it, substantially as described.

10 4. In a vessel-hull, the combination with longitudinal members, outside frames and inner frames, said outside frames being notched

into the longitudinal members, of planking fastened along its abutting edges to such longitudinal members, substantially as described.

This specification signed and witnessed this 4th day of September, 1903.

HENRY NEWTON WHITTELSEY.

Witnesses;

LEONARD H. DYER,
JOHN L. LOTSCH.