

J. Scott.
Refrigerator.

N^o 1684.

Patented Jul. 10. 1840.

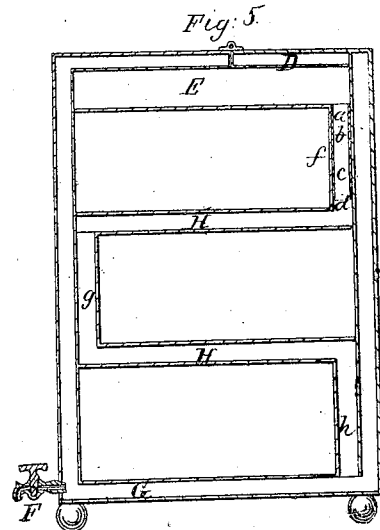
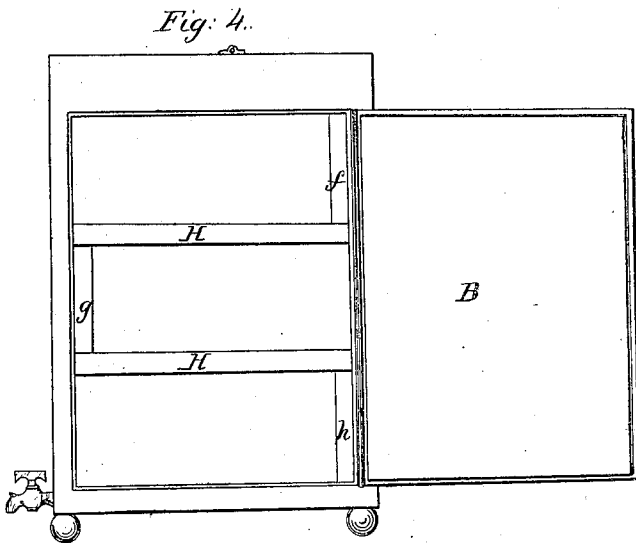
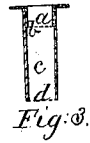
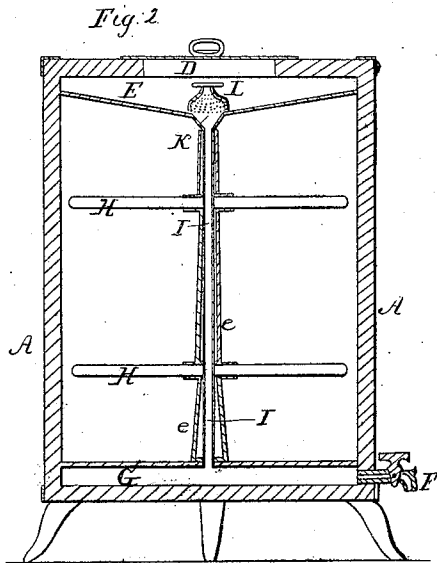
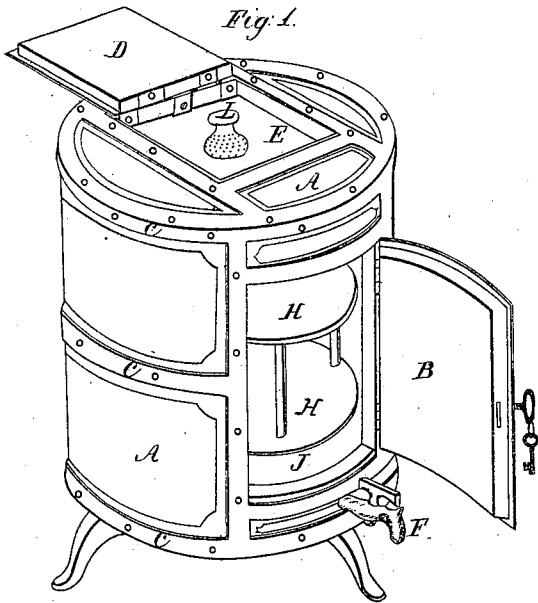

UNITED STATES PATENT OFFICE.

JOHN SCOTT, OF PHILADELPHIA, PENNSYLVANIA.

CONSTRUCTION OF REFRIGERATORS.

Specification of Letters Patent No. 1,684, dated July 10, 1840.

To all whom it may concern:

Be it known that I, JOHN SCOTT, of the city of Philadelphia, in the State of Pennsylvania, have invented certain improvements in the manner of constructing refrigerators for the purpose of cooling, and thus preserving, articles of food of various kinds during the warm season of the year; and I do hereby declare that the following is a full and exact description thereof.

I construct my refrigerators principally, or entirely, of sheet metal, and make them either in the form of a parallelogram, a vertical cylinder, or oval, or in any other shape that may be preferred. In whatever form I make them, they are to consist of two cases of sheet metal, one placed within the other, so as to leave a space of an inch, more or less, between the two, which space may be occupied by air, or may be filled in with any fibrous, or pulverized, bad conductor of heat. Where there are openings through this double case, the two bodies are to be united by sheet metal, or, in preference, by wood, formed into strips, so as to be interposed between, and connected with, the two casings, at the edges of such openings. The tops and bottoms of these refrigerators, as well as the sides, are to be double.

My principal improvement in such refrigerators consists in my forming a chamber for receiving ice, in the upper part thereof; and a second chamber for the reception of the water produced by the melting of the ice, in the lower part, with suitable openings for the passage of the water from one chamber to the other by the descent of which cold water every part of the apparatus is cooled.

In the accompanying drawing, Figure 1, is a perspective view of the refrigerator, in the form of a vertical cylinder; Fig. 2, a vertical section of the same through its center.

In Fig. 1, A, A, is the cylindrical case; B, a door opening into its interior; C, C, bands of metal for strengthening the case; D, a door at the top, opening into the upper chamber E, within which the ice is to be placed; F, is a cock for drawing off the water from the lower chamber, when necessary. This lower chamber is shown at G, Fig. 2; similar parts in both figures being designated by the same letters of reference.

H, H, are shelves, which in this form of the apparatus are made to revolve around a

center tubular shaft I, I, Fig. 2, this being necessary to afford convenient access to them; J, J, is the plate which forms the bottom of the interior of the refrigerator, and constitutes the top of the lower chamber; K, is a cavity on the top of the tube I, within which a sponge is to be placed to prevent the passing down of any foreign matter; and to this cavity is adapted a perforated cover L. Instead of making the depression K, in the plate forming the bottom of the chamber E, I prefer to employ a filtering tube, such as is shown in section in Fig. 3, an enlargement adapted to its reception being formed in the upper part of the tube I. The part *a*, of the filtering tube, is to contain a piece of sponge; the dotted line *b*, shows the perforated bottom of this compartment; below this, in the cavity *c*, I put coarse sand, or fine gravel, below which there is a perforated bottom *d*, the action of which needs no further illustration.

In Fig. 2, *e, e*, are tubes which support the shelves, and revolve around I, I.

Fig. 4, is a front view of my refrigerator, made square, and with fixed shelves; and Fig. 5, a vertical section through it, from side to side. In this form, the shelves H, H, are stationary, and each consists of two sheets of metal between which the water is to pass in its passage from the ice chamber E, to the water chamber G. From the chamber E, a flat tube, or channel, *f*, allows a passage for the water to the interior of the upper shaft, along which it passes, and then through a similar passage *g*, to the second shelf, and thence through *h*, to the water chamber G. A filterer, different in form but the same in construction with that shown in Fig. 3, is inserted in the tube, or cavity, *f*, as will be seen by the letters of reference.

Having thus fully described the manner in which I construct my refrigerator, what I claim as new therein, and as of my invention, is—

The forming it with an upper and lower chamber, in the manner described, the upper chamber being intended to contain ice, and the lower to receive the water produced by the melting thereof, said water descending from the upper to the lower chamber through tubes, or channels constructed substantially in the manner set forth, so as in its descent to exert its refrigerating influence within the refrigerator.

In the construction of this kind of apparatus I do not mean to confine myself to the use of any particular kind of metal, but my practice is to make the exterior case of sheet-
5 iron, and the interior one of zinc; and I intend sometimes to coat the latter with tin, which will protect it from oxidation.

In testimony that the foregoing is a true

specification of my invention, I have here-
unto set my hand in presence of two wit- 10
nesses, this eighth day of June 1840.

JOHN SCOTT.

Witnesses:

THOS. P. JONES,

GEO. WEST.