

G. BUTLER.
Car-Coupling.

No. 213,974.

Patented April 8, 1879.

Fig. 1.

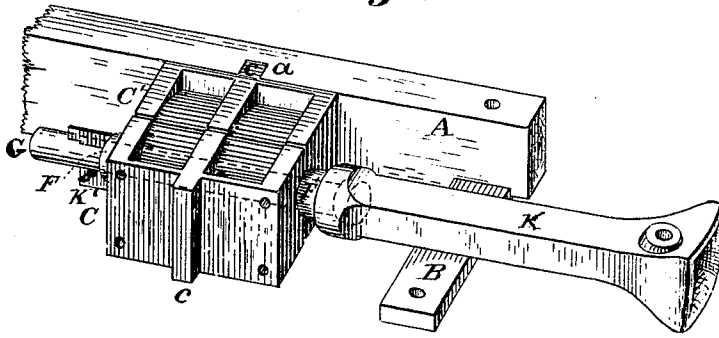

Fig. 2.

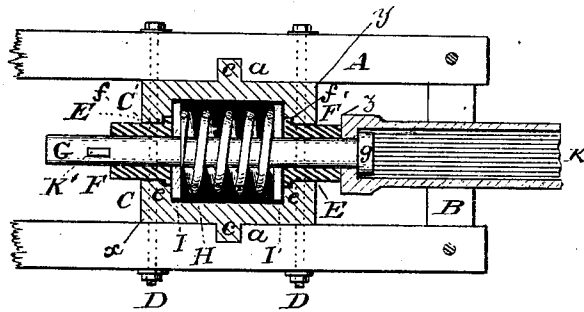
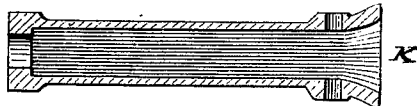

Fig. 3.



Fig. 4.



Attest.
Walter Knight
Harry Knight

Inventor:
George Butler
By Knight Bros
Atty.

UNITED STATES PATENT OFFICE.

GEORGE BUTLER, OF CINCINNATI, OHIO.

IMPROVEMENT IN CAR-COUPINGS.

Specification forming part of Letters Patent No. 213,974, dated April 8, 1879; application filed September 2, 1878.

To all whom it may concern:

Be it known that I, GEORGE BUTLER, of Cincinnati, Hamilton county, Ohio, have invented a new and useful Improvement in Draw-Bars, of which the following is a specification:

My invention relates to improvements in those draw-bars for railway-cars which are held to their proper protruded position by a suitable spring secured to the bed or body frame.

The draw-bar consists of a housing formed in two parts, and having in its front wall orifices to receive sleeves or thimbles, said orifices being counterbored to receive the flanged necks of said sleeves, which necks operate against washers at each end of the housing, to compress a spiral spring sliding on the draw-bar, which extends through said housing and sleeves.

In the accompanying drawings, Figure 1 is a perspective view of a draw-bar embodying my invention. Fig. 2 is a horizontal section of the same, a portion of the head being omitted. Figs. 3 and 4 are, respectively, a side view of the tail-bar, and a longitudinal section of the head separated from the housing and from each other.

A B may represent, respectively, portions of the draft-timbers and the carry-iron of a car-body. C C' represent the two members of a stout cast-iron box, of rectangular external and cylindrical internal conformation.

Tongues *a*, that project from the box, occupy jogs *a* in the draft-timbers, to which the box is further secured by through-bolts D.

The front and back walls of the box have in their parting-line circular orifices E, counterbored at *e*, for the reception of correspondingly-formed sleeves or thimbles F F', which receive the tail rod or bar G.

A spiral spring, H, being inserted in the box between a pair of washers, I I', operates to hold the flanged necks *f* of the sleeves snugly within the counterbores, as clearly shown in Fig. 2.

The rod G has a head, *g*, so that after said rod has been inserted in the draw-head K said rod is securely retained therein, as seen in Fig. 2.

After such insertion said rod may be passed entirely through the spring-box, as seen in Fig. 2, and be retained therein by a key, K'.

The substitution of a new head for a broken or damaged one can be made at any moment by one man, by simply reversing and repeating the above-described manipulations.

In the event of a violent collision the burden of resistance is distributed between the rear wall, *x*, and the front wall, *y*, of the box, in consequence of the rear extremity, *z*, of the head colliding with the front wall, *y*; and hence the housing, with its spring mechanism, is less liable to derangement or fracture.

It is apparent that any stress upon the draw-head, whether of thrust or draft, will result in pressing the forward or hindward thimble, as the case may be, which, in turn, pressing on its washer, must operate to compress the spring in that direction until the active and resisting forces are *in equilibrio*.

The spring-housing may be withdrawn for repair or inspection by first removing the draw-bar and screw-bolts, and then withdrawing the box vertically from its place between the draft-timbers. After liberation, as above, the two halves of the box may be separated, so as to fully expose the spring and other contents.

I claim as new and of my invention—

The draw-bar herein described, consisting of the housing C C', having at its front walls circular orifices counterbored at *e*, sleeves or thimbles F F', having flanged necks *f*, fitting in said counterbores *e*, and operating against washers I I' at each end of a spiral spring, H, draw-head K, carrying the draw-bar G, upon which said sleeves and spring slide, and operating to press said thimbles, compress the spring, and distribute the pressure evenly within and without the housing, substantially as set forth.

In testimony of which invention I hereunto set my hand.

GEORGE BUTLER.

Attest:

WALTER KNIGHT,
GEO. H. KOLKER.