

Feb. 14, 1933.

W. I. STAAF, SR

1,897,962

ROTARY INTERNAL COMBUSTION ENGINE

Filed March 20, 1929

5 Sheets-Sheet 1

Fig. 1.
II

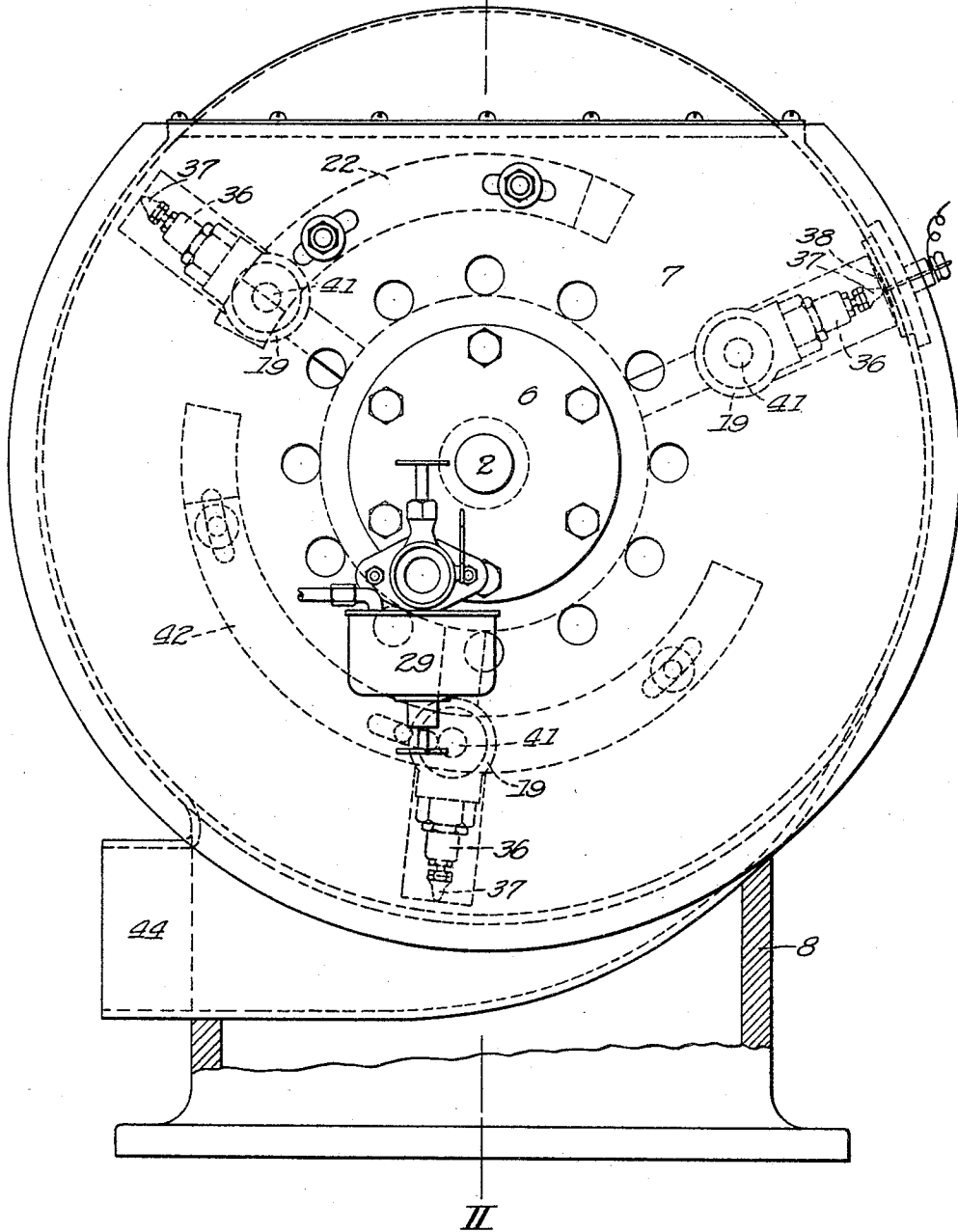

INVENTOR
Werner I. Staaf, Sr.
by C. M. ...
attorney

Feb. 14, 1933.

W. I. STAAF, SR

1,897,962

ROTARY INTERNAL COMBUSTION ENGINE

Filed March 20, 1929

5 Sheets-Sheet 2

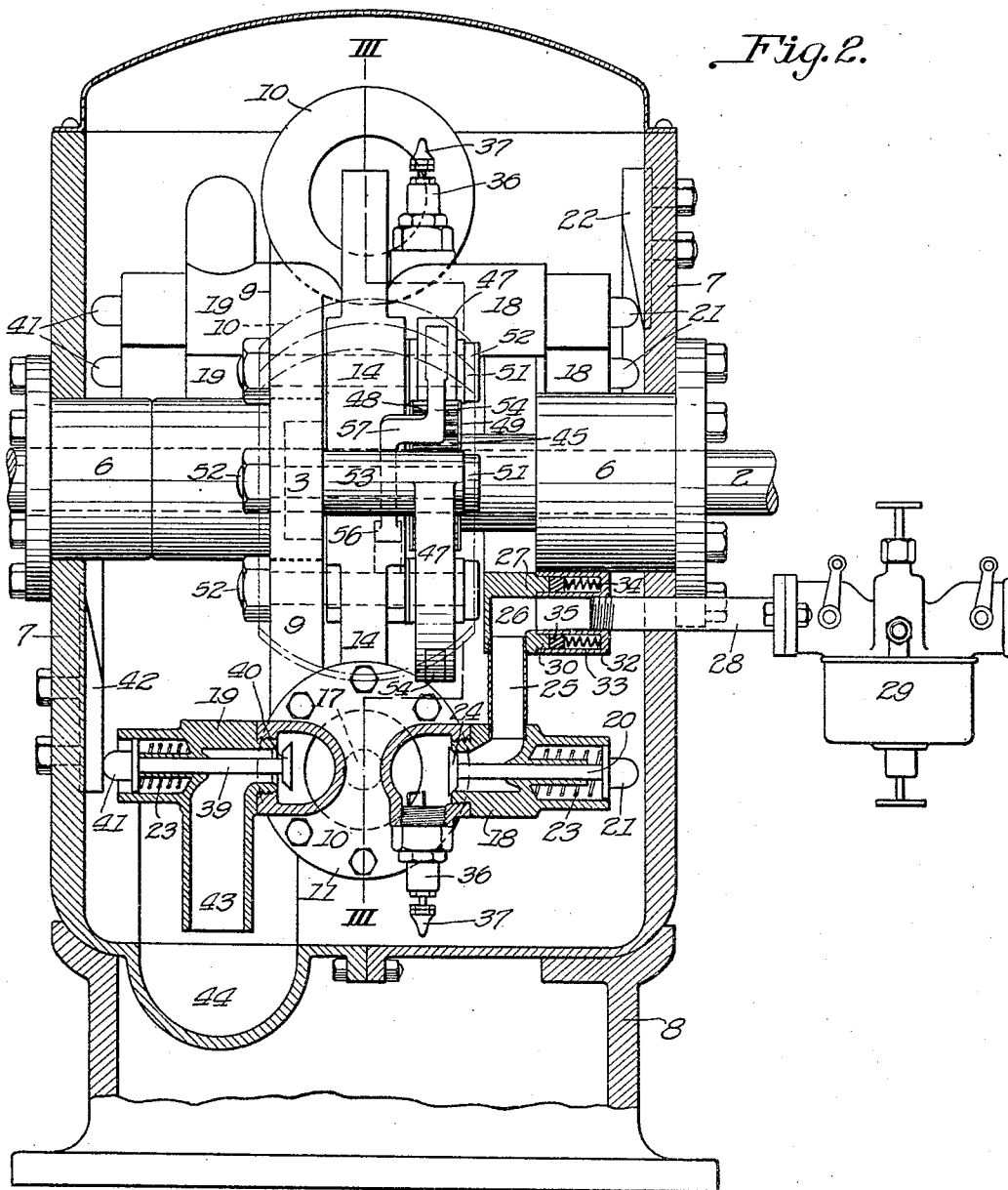

INVENTOR
Werner I. Staaf, Sr.
by *W. M. Clark*
Attorney

Feb. 14, 1933.

W. I. STAAF, SR

1,897,962

ROTARY INTERNAL COMBUSTION ENGINE

Filed March 20, 1929

5 Sheets-Sheet 3

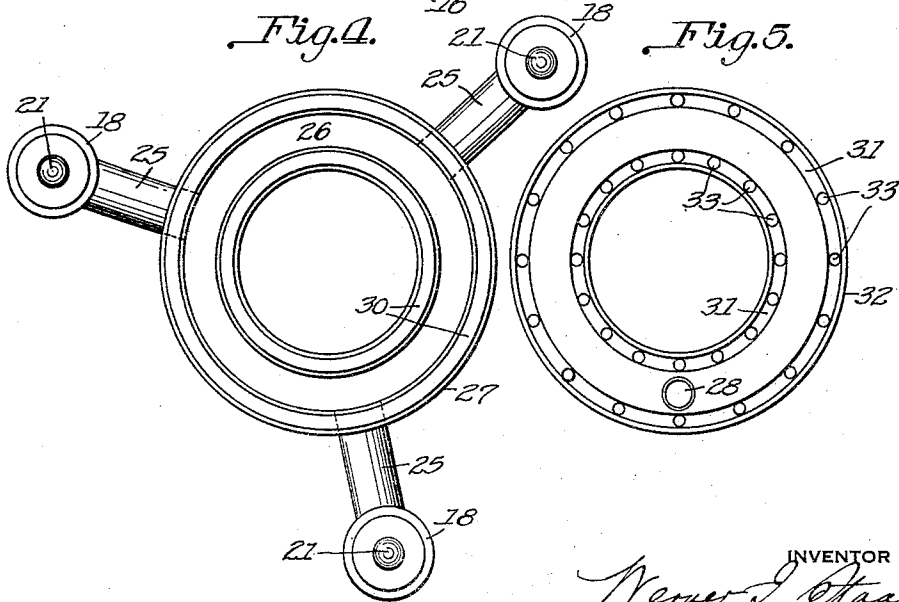
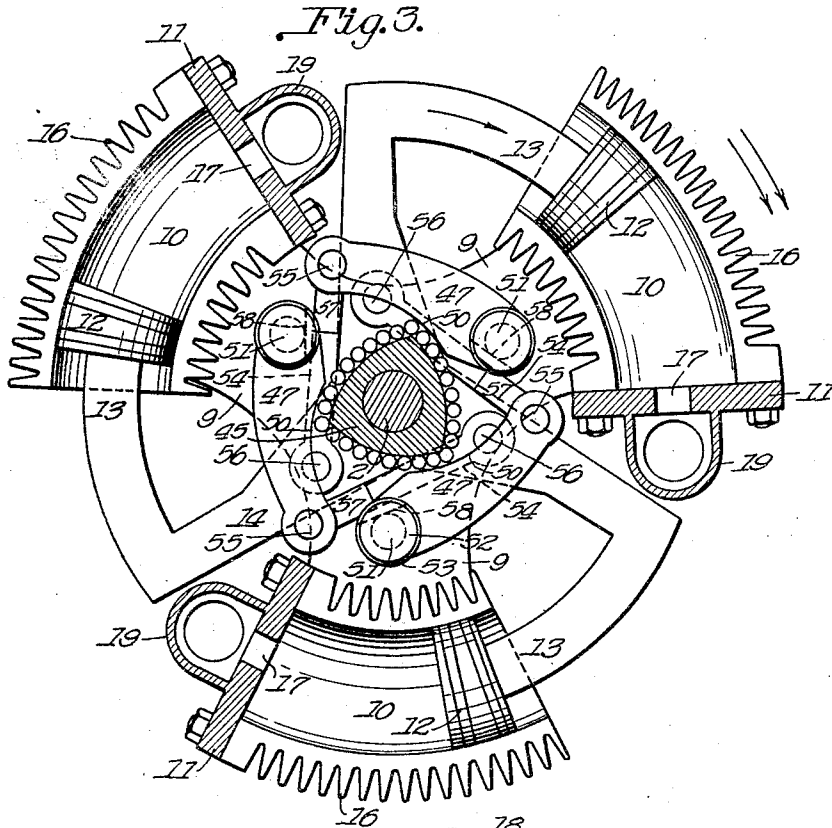

INVENTOR
Kerner J. Staaf, Sr.
by *C. M. Clark*
Attorney

Feb. 14, 1933.

W. I. STAAF, SR

1,897,962

ROTARY INTERNAL COMBUSTION ENGINE

Filed March 20, 1929

5 Sheets-Sheet 5

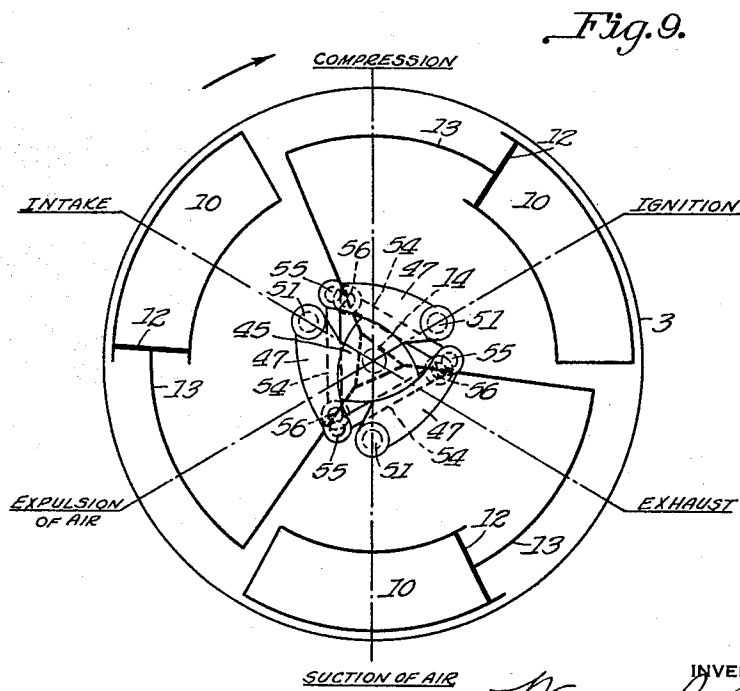
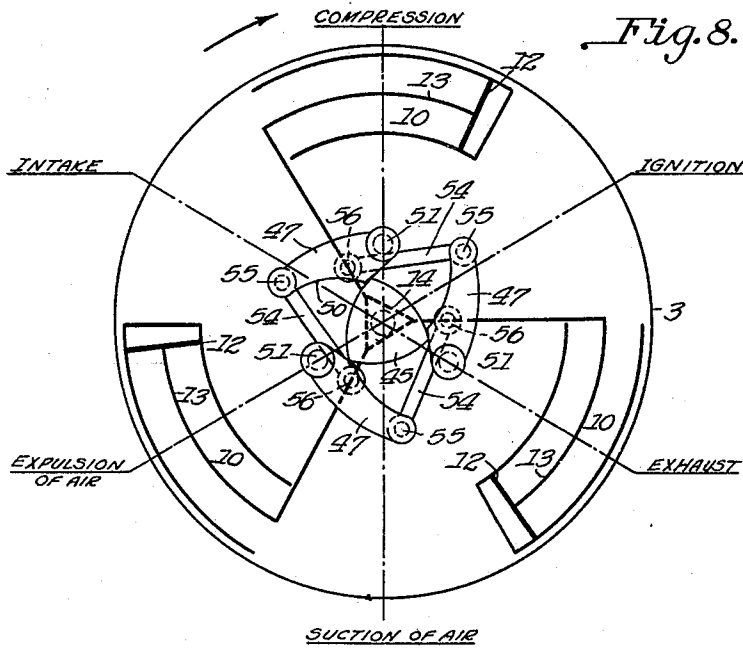

INVENTOR
Werner I. Staaf
by *Chas. M. Clark*
attorney

UNITED STATES PATENT OFFICE

WERNER I. STAAF, SR., OF PITTSBURGH, PENNSYLVANIA, ASSIGNOR OF FIFTY-ONE ONE-HUNDREDTHS TO WILLIAM W. MARTIN, OF PITTSBURGH, PENNSYLVANIA; HANNAH STAAF, ADMINISTRATRIX OF SAID WERNER I. STAAF, SR., DECEASED

ROTARY INTERNAL COMBUSTION ENGINE

Application filed March 20, 1929. Serial No. 348,460.

My invention refers to improvements in rotary engines of the internal combustion type and operating on the six-cycle principle. It has in view to provide a construction whereby the efficient force or power of an explosive mixture may be utilized for direct transmission of power to a main shaft, without the use of intervening connecting rods, but with relative reciprocation of plungers and cylinders.

The invention comprises a main rotatable frame keyed to or otherwise secured to the main power imparting shaft having one or a series of annularly arranged curvilinear cylinders, together with one or more reciprocating co-operating plunger heads or pistons, and means controlling their movement. The movement of the plunger heads is alternately retarded and accelerated relative to the uniform movement of the cylinders, both plungers and cylinders moving around the shaft center with such variable relative speeds and with complete compensation for the alternating differentials, throughout each complete cycle of operation.

The cylinders are made as fixed portions of the main rotatable frame and impart to it annular movement at each explosion for transmission of power to the connected shaft, while the plunger heads and their holding frame are freely rotatable around the shaft, with their resisting mechanism, and at reduced speed, and act as receding abutments against which the expanding gases act. The plungers are also alternately caused to reverse their movements after each explosion with accelerated movement, to expel the waste gases, then at reduced speed to effect suction of scavenging air, then at increased speed to expel such air and remaining products of combustion, then at reduced speed to effect suction of the new charge of explosive mixture, then at increased speed to effect compression, when the mixture is ignited with resulting explosion and propulsion of the cylinder and head, completing the cycle.

The engine is provided, as to each cylinder, with an admission or inlet and an exhaust valve each having a cam-actuated stem, the inlet valve being in constant communica-

tion through a hollow rotatable ring with the mixture supply. The exhaust outlet for waste gases opens into the interior of a surrounding casing adjacent a suitable exhaust conduit thereof.

The casing as a whole provides bearings at each end for the main shaft and is provided at one end with an inwardly extending support for a stationary cam element around and against which the controlling arms for the plunger heads are arranged and bear. These arms are pivotally connected at one end with the main rotatable frame and by links with the plunger head arms, as hereinafter described.

The engine as a whole and its several parts in one preferred embodiment of the invention are illustrated in the accompanying drawings, in which:

Fig. 1 is a view of the engine in end elevation;

Fig. 2 is a vertical section on the line II—II of Fig. 1, with the middle portion in elevation;

Fig. 3 is a vertical section on the line III—III of Fig. 2, showing the relative arrangement of the cylinders and plungers in open position;

Fig. 4 is a detail view of the rotatable hollow supply ring for the fuel;

Fig. 5 is a similar view of the relatively stationary bearing ring therefor;

Fig. 6 is a view like Fig. 3 showing the relative arrangement of the cylinders and plungers in closed position;

Fig. 7 is a partial sectional view on the line VII—VII of Fig. 6;

Figs. 8 and 9 are diagrammatic views illustrating the successive relative positions of the cylinders and plungers throughout one complete cycle.

Referring to the drawings, 2 is the main power imparting shaft through and from which by suitable means as a pulley or the like, rotative movement is imparted from the cylinder supporting frame 3 which is keyed to the shaft, as at 4.

Shaft 2 is mounted in suitable bearings 5, the hubs 6 of which are mounted upon and extend inwardly from the main surrounding

casing or frame 7. Casing 7 is of generally cylindrical form mounted upon a suitable supporting base 8 of any desired design, and encloses the operative elements of the engine except the carburetor, as shown in Figs. 1 and 2.

The cylinder-supporting frame 3 is preferably in the form of a single casting having the radially disposed portions 9, carrying the several cylinders 10. Said cylinders as shown, are arranged annularly of the shaft center and, for purposes of facilitating their manufacture, are preferably made in two halves. One such half is made as an integral portion of frame 9 and the other half is bolted or otherwise secured thereto, and to the closing head 11 of each cylinder.

By such construction the halves of the cylinder may be machined so as to result in a continuously smooth interior, similar to the usual straight cylinder, but conforming to the arc of curvature from one end to the other, for reception and reciprocable operation of plunger 12.

Said plunger is also machined to make a tight sliding fit within the cylinder, having suitable packing rings as shown, and capable of movement therein forwardly and backwardly with relation to head 11, as hereinafter described.

Plunger or piston head 12 is secured to the end of arcuate arm 13 of the spider frame 14, which is freely journalled around shaft 2, preferably with an intervening bushing 15 for easy movement thereon. The walls of cylinders 10 are fluted or ribbed, as at 16, providing for rapid radiation of heat and cooling of the several cylinders and each head 11 is provided with an inlet and outlet port 17, communicating with the casing or shell of inlet valve 18 and of outlet valve 19.

Inlet valve 18 is provided with a stem 20 having a terminal button 21 for engagement against an actuating cam 22 annularly arranged around the adjacent inner side of the casing 7. A retracting spring 23 normally holds stem 20 extended and closes the valve 24 of the valve casing against its seat, as in Fig. 2, until the valve is opened by action of cam 22 at the proper time, for supply of explosive mixture. Such supply is furnished through conduit or pipe 25 by which each valve shell 18 is connected with the annular interior space 26 of a hollow ring 27, in constant communication with the fuel.

Ring 27, as shown, is thus fixedly connected with each of the several supply valve casings 18 and rotates therewith during operation of the engine. Cavity 26 is open at one side entirely around the face of the ring and in register with supply conduit or pipe 28 leading from the carburetor 29 of any suitable construction, mounted on the outside of the main casing, as shown.

For the purpose of providing a mounting

ring 27, interfits by extended ring-terminals or tongues 30 in corresponding receiving grooves 31 of the fixed ring 32, mounted around one of the hubs 6.

For the purpose of packing the joint between said rings, ring 32 is provided with annular series of sockets 33 in which are mounted springs 34 and annular bearing rings 35. The latter bear against the edges of ring extensions 30, and provide a sufficient packing to ensure against leakage of the gaseous mixture being supplied to the several inlet valves from the carburetor during operation of the engine.

Each inlet valve 18 is provided with a suitable ignition device, as a spark-plug 36, or such plug may be suitably located at any point in the path of the mixture to the explosive chamber of each cylinder 10. Each spark-plug is provided with a terminal 37 adapted to come into contact with circuit terminal 38, located at the proper position for ignition of the compressed mixture, as shown in Fig. 1.

At the opposite side of each cylinder head, the exhaust valve 19 is constructed and operates in a generally similar manner, for outlet of the waste gases, and discharge thereof to the exterior of casing 7. For such purpose the steam 39 of opening and closing valve 40 is similarly spring-retracted, and is provided with a terminal button 41 adapted to be depressed by engagement against the annular face of cam 42, secured to the inner face of the opposite side of casing 7, as in Fig. 2.

Valve casing 19, as thus constructed, is in open communication with the interior of each cylinder through port 17 so that at the proper time the waste gases may be discharged through a discharge conduit 43.

The lower side of the casing, at one side and in register with conduit 43, is provided with an outlet shell or conduit 44 opening to the atmosphere for discharge of the waste gases. Cam 42, as indicated in Fig. 1, is of considerable length so that the valve 40 will be maintained open for such exhaust of waste products, and for intake of scavenging air and for discharge thereof at periods of each cycle, as indicated in Figs. 8 and 9, and as hereinafter more fully described.

It will be understood therefore that by such continuity of the flat face of the cam, valve 40 is held open for such purpose, and thereafter closed by its retracting spring 23, during intake, compression and explosion of the gaseous mixture, being open thereafter for exhaust, suction of air, and expulsion of air, as stated.

As before mentioned, the several cylinders and their several plungers rotate together, the rotation of the cylinders being at a uniform speed while the accompanying rotation of the plungers is at a variable speed, in the same direction, alternately accelerated and

retarded with relation to the normal speed of the cylinders. Such operation is due to the controlling action of a centrally arranged cam member 45 which is held in a rigid stationary position by neck 46 of bearing 6, surrounding shaft 2, as in Fig. 7.

Cam 45 is approximately triangular in form, but with its sides outwardly bowed or of arcuate form, for co-operation with the several controlling links 47. Cam 45, as thus constructed, is provided with a plurality of high or extended terminal points, corresponding in number to the number of the cylinders, as three, with an intermediate low point, half-way between such high points or at the middle of the arcuate portion, where link 47 is at its innermost position, as in Fig. 9.

Arms 47 when bearing on the high points of the cam are at their outermost position, corresponding to the terminal position of the plungers on inward movement, as in Fig. 8.

For the purpose of providing rolling bearings for the inner edges or faces of arms 47, cam 45 is provided with a continuous annularly arranged series of rollers 48 retained on the cam by side plates 49, as in Fig. 7. The inner face 50 of each arm 47 is curved approximately to the curvature of the arcuate surface of such rollers, around the cam, so that it may lie snugly thereon when in innermost position, and will ride upwardly away therefrom in outermost position, when the arm is riding over the extended corner portion of such series, around the triangular-shaped cam.

Each arm 47, as thus made, is pivotally connected, at 51, by a bolt 52 extending through hub 53 of the arm and through the web portion 9 of frame 3 forming an integral or fixed connecting frame between the several cylinders 10. Each such arm 47 is connected by link 54 with arm 14 by pivotal connections 55 and 56 respectively, the links being off-set as at 57 for clearance, allowing for under-lapping with relation to arms 47, while hubs 53 may be cut out for clearance of the edges of the links 54, as at 58, avoiding interference, as in their extended position when the plungers are inserted in the cylinders, as in Fig. 6.

By such construction and arrangement it will be seen that as each cylinder 10 with its mixture compressed at the extreme inner movement of its plunger, and with the ignition effected through the spark-plug, and with lever 47 just riding over the high point of the cam toward its receding face, plunger 12 will be maintained through connections 13, 14, 56, 54, 55 and 51 as an abutment opposing action of the exploded gases, which thereby exert their propelling force against head 11 of the cylinder and utilizing such force to propel frame 9 around the shaft cen-

ter, with such movement or power transmitted to the shaft.

As the frame 9, under such impulse, moves around the stationary cam, arms 47 are constantly held inwardly against the cam due to the re-active action of the gases, at which time exhaust valve 19 is opened by cam 42 for exhaust. At the same time the other cylinders being carried around by frame 9 are effecting their functions as to suction and expulsion of air, intake of the new mixture, and compression, successively, so that when the next oncoming cylinder arrives at the ignition station the preceding cylinder which has just been exhausted, is then in position for suction of air, at the moment of ignition of its next following cylinder.

Such ignition, in the same manner, effects reverse pressure against its plunger, and the several plungers being connected by the spanner frame 14, the other plungers 12 effect their functions by corresponding retarded movement, i. e., at retarded speed so as to effect such suction of air and of intake of the new mixture at the proper stations of the cycle, as in the diagrams, Figs. 8 and 9.

It will thus be seen that such relative movement of the plungers not subject at the moment to explosive action of the gases, are controlled by the action of the particular plunger which is so subject at the ignition station. Also, that, due to the re-active action of each plunger at the point of ignition, the several spider arms 14 operate together, maintaining the several links 47 in close operative contact against the rollers of the cam, throughout each entire revolution.

As indicated in Figs. 3 and 6, the normal speed of the rotatable frame 9 and its pistons is indicated by double arrows.

The relatively reduced speed of the plungers and their connecting spider frame 14, when under explosive action upon ignition, in effecting suction of air and intake of the mixture, is indicated by a single arrow, as in Fig. 3, while the relatively increased speed of the plungers and their spider frame in compression, exhaust and air expulsion positions respectively, is indicated by triple arrows, as in Fig. 6.

From the foregoing it will be seen that the engine as a whole functions on a six-cycle or station operation throughout each complete revolution. Thus, upon ignition of the compressed mixture, the several cylinders advance beyond their plungers upon explosion, followed by exhaust of the burned gases from the active cylinder, then followed by suction of air, then by expulsion of air, then by intake of the explosive mixture, and then by compression thereof, prior to the next ignition, as clearly illustrated in Figs. 8 and 9.

While I have not shown any means for lubricating the working parts of the engine, it will be understood that usual or suitable

means are to be used for supplying oil, grease or other suitable lubricant to all friction producing surfaces.

The frame 9 and its cylinders when in motion also operate as a fly wheel and tend to equalize and regulate the torque of the drive shaft 2. If desired, however, an ordinary fly wheel may be also mounted on the shaft for advantage of its momentum.

The construction and operation of the engine will be readily understood and appreciated from the foregoing description by those skilled in the art. While I have shown and described one preferred embodiment of the invention, it will be understood that various changes or modifications may be made by the skilled mechanic in detail construction within the scope of the following claims.

What I claim is:—

1. In an internal combustion rotary engine having a rotatable drive shaft, a surrounding rotatable frame fixed to said shaft having a series of curvilinear cylinders concentric with the shaft, and a rigid frame freely journalled around the shaft having a corresponding series of cylinder plungers and connecting arms therefor; mechanical movement means controlling relative movement of the cylinders and plungers consisting of a fixed cam surrounding the shaft having a series of arcuate roller bearing faces corresponding in number to the number of cylinders and plungers, a link pivotally connected with each plunger arm, and cam-engaging arms therefor pivoted on the cylinder frame and to each of said links, each arm having an arcuate face conforming to the arcuate roller bearing faces of the cam.

2. In an internal combustion rotary engine having a rotatable drive shaft, a surrounding rotatable frame fixed to said shaft having a series of curvilinear cylinders concentric with the shaft, and a rigid frame freely journalled around the shaft having a corresponding series of cylinder plungers and connecting arms therefor; mechanical movement means controlling relative movement of the cylinders and plungers consisting of a fixed cam surrounding the shaft having a series of arcuate faces corresponding in number to the number of cylinders and plungers, a link pivotally connected with each plunger arm, and cam-engaging arms therefor pivoted on the cylinder frame and to each of said links, each arm having an arcuate face conforming to the arcuate face of the cam terminating at a maximum distention point engageable with the outermost of the several cam terminals between its arcuate faces.

3. An internal combustion rotary engine comprising a rotatable drive shaft, a surrounding rotatable frame fixed to said shaft having a series of three equally spaced curvilinear cylinders concentric with the shaft, a rigid frame freely journalled around the

shaft having a corresponding series of cylinder plungers and pivoted connecting arms therefor, a fixed cam surrounding the shaft having three equal arcuate faces, a link pivotally connected with each plunger arm, and a cam-engaging arm for each plunger pivoted to one of said links and to the cylinder frame and having an arcuate face conformable to the arcuate faces of the cam.

4. An internal combustion rotary engine comprising a rotatable drive shaft, a surrounding rotatable frame fixed to said shaft having a series of three equally spaced curvilinear cylinders concentric with the shaft, a rigid frame freely journalled around the shaft having a corresponding series of cylinder plungers and pivoted connecting arms therefor, a fixed cam surrounding the shaft having three equal arcuate faces terminating at equal maximum distances from the shaft center, a link pivotally connected with each plunger arm, and a cam-engaging arm for each plunger pivoted to one of said links and to the cylinder frame and having an arcuate face conformable to the arcuate faces of the cam terminating in a shoulder engageable with the maximum distance terminals of the arcuate faces of the cam.

In testimony whereof I hereunto affix my signature.

WERNER I. STAAF, Sr.