

(19)



(11)

EP 2 601 111 B1

(12)

EUROPEAN PATENT SPECIFICATION

(45) Date of publication and mention of the grant of the patent:
08.10.2014 Bulletin 2014/41

(51) Int Cl.:
B65D 41/30 (2006.01) B65D 51/18 (2006.01)
B65D 81/24 (2006.01)

(21) Application number: **11743930.7**

(86) International application number:
PCT/US2011/046641

(22) Date of filing: **04.08.2011**

(87) International publication number:
WO 2012/019039 (09.02.2012 Gazette 2012/06)

(54) CONTAINER CAP AND SEAL ASSEMBLIES

VERSCHLUSS- UND DICHTUNGSANORDNUNGEN FÜR EINEN BEHÄLTER
ENSEMBLES RÉCIPIENT, BOUCHON ET OPERCULE

(84) Designated Contracting States:
AL AT BE BG CH CY CZ DE DK EE ES FI FR GB GR HR HU IE IS IT LI LT LU LV MC MK MT NL NO PL PT RO RS SE SI SK SM TR

- **TSE, Kieron H.**
Chicago, Illinois 60642 (US)
- **GROCHOWSKI, Jason Paul**
Crown Point, Indiana 46307 (US)

(30) Priority: **05.08.2010 US 371080 P**

(74) Representative: **f & e patent**
Fleischer, Engels & Partner mbB, Patentanwälte
Braunsberger Feld 29
51429 Bergisch Gladbach (DE)

(43) Date of publication of application:
12.06.2013 Bulletin 2013/24

(73) Proprietor: **PRC-Desoto International, Inc.**
Sylmar, California 91342 (US)

(56) References cited:
GB-A- 2 026 995 US-A- 4 383 619
US-A- 4 386 712 US-A- 4 394 923

(72) Inventors:
• **PEREZ, Daniel**
Chicago, Illinois 60609 (US)

Note: Within nine months of the publication of the mention of the grant of the European patent in the European Patent Bulletin, any person may give notice to the European Patent Office of opposition to that patent, in accordance with the Implementing Regulations. Notice of opposition shall not be deemed to have been filed until the opposition fee has been paid. (Art. 99(1) European Patent Convention).

EP 2 601 111 B1

Description

FIELD OF THE INVENTION

[0001] The present invention relates to container closures, and more particularly relates to container, cap and seal assemblies for pastes, liquids and other materials according to the preamble of claim 1; to a cap and seal assembly according to the preamble of claim 10; and to a method of sealing a container according to the preamble of claim 11.

BACKGROUND INFORMATION

[0002] Various types of container closures are known. For example, conventional solder paste jars have a base, a cap and a separate seal for minimizing air contact with the paste contained in the jar. Such seals are in the form of either a slidable piston that is pressed down in the base of the jar against the upper surface of the solder paste, or top seal installed in the region between the cap and the upper rim of the base. Although such standard seals may effectively prevent air from contacting the solder paste, they require additional steps during the manufacturing process in order to separately install the seal in the jar after the jar is filled but before the cap is secured to the base of the jar.

SUMMARY OF THE INVENTION

[0003] An aspect of the present invention is to provide a container, cap and seal assembly comprising a container base according to claim 1.

[0004] Another aspect of the present invention is to provide a cap and seal assembly for a container according to claim 10.

[0005] A further aspect of the present invention is to provide a method of sealing a container according to claim 11.

[0006] These and other aspects of the present invention will be more apparent from the following description.

BRIEF DESCRIPTION OF THE DRAWINGS

[0007]

Fig. 1 is a cutaway isometric view illustrating a container base, cap and seal arrangement in accordance with an embodiment of the present invention. Fig. 2 is an exploded cutaway isometric view of the container assembly of Fig. 1.

Fig. 3 is a cutaway isometric view of the cap and seal arrangement of the solder paste container assembly of Fig. 1, illustrating how the cap and seal are attached together as a single unit when they are initially installed on the base of the container.

Fig. 4 is a cutaway isometric view of the seal secured on the base of the container with the cap removed,

illustrating how the seal is disengaged from the cap when the cap is removed from the base of the container.

Fig. 5 is an isometric view of a container base in accordance with an embodiment of the present invention.

Fig. 6 is a side view of the container base of Fig. 5. Fig. 7 is another side view of the container base of Fig. 5.

Fig. 8 is a cross sectional view taken through line 8-8 of Fig. 7.

Fig. 9 is a longitudinal sectional view taken through line 9-9 of Fig. 7.

Fig. 10 is an isometric view of a container cap in accordance with an embodiment of the present invention.

Fig. 11 is a sectional view of the container cap of Fig. 10.

Fig. 12 is an enlarged view of a portion of the container cap of Fig. 11.

Fig. 13 is a sectional view of a container seal in accordance with an embodiment of the present invention.

Fig. 14 is an enlarged view of a portion of the container seal of Fig. 13.

DETAILED DESCRIPTION

[0008] As shown in Figs. 1-4, a container assembly 10 in accordance with an embodiment of the present invention includes a container base 20, a cap 30 and a seal member 40. An additional piston seal 50 is shown installed in the base 20 of the container 10. However, it is to be understood that the piston seal 50 may be optional when the seal member 40 is used. In certain embodiments of the invention, the container assembly 10 may be used to contain solder paste. However, it is to be understood that other types of pastes, liquids and flowable materials may be contained in the container assembly 10.

[0009] As shown in Figs. 1-9, the base 20 is generally cylindrical, with a rounded interior bottom portion 21 which facilitates removal of solder paste or other materials from the bottom of the container base 20. A threaded closure 22 is provided at the upper edge 24 of the base 20. An annular rim 25 surrounds the base 20. Ridged stop members 26 are spaced 180 degrees around the outer circumference of the base 20 and extend radially outward from the base 20 adjacent to the annular rim 25. In the embodiment shown, the threaded closure 22 is in the form of a quarter-turn closure which requires the cap to be turned only 90 degrees to close the container. However, any other suitable closure arrangement may be used, such as other threaded closures, snap-fit caps, etc.

[0010] As shown in Figs. 1-4 and 10-12, the cap 30 includes quarter-turn threads 32 that engage the respective quarter-turn threads 22 of the base 20. It is noted that the quarter-turn threads 32 may be replaced with any other threaded arrangement, as well as any other

suitable closure arrangement such as a snap-fit cap as described above. The cap 30 includes a downwardly extending annular ring 34 with a beveled edge 35. As more fully described below, the seal member 40 is temporarily held on the cap 30 through engagement with the ring 34. Ridged stop members 36 are spaced 90 degrees around the inner circumference of the lid 30 and extend radially inward from the lid to engage the ridged stop members 26 of the base 20. When the cap 30 is secured on the base 20, two of the ridged stop members 36 engage the opposing ridged stop members 26 of the base 20 to provide tactile feedback when the cap 30 is hand-tightened. Although two ridged stop members 26 are shown on the base 20, and four ridged stop members 36 are shown on the cap 30, any other suitable number and shapes of tactile stop members may be used.

[0011] As shown in Figs. 1-4, 13 and 14, the seal member 40 has a generally cylindrical sidewall 42 and an annular rim 43 that extends radially outward from the sidewall 42. A lower surface of the annular rim 43 contacts the upper edge 24 of the base 20. The generally cylindrical sidewall 42 is connected to a radially inwardly extending rim 44 with a circular flange 45. In the embodiment shown, the inwardly extending rim 44 has a generally conical shape, however, any other suitable shape may be used.

[0012] At least a portion of the outer surface of the cylindrical sidewall 42 contacts the inner surface of the upper portion of the base 20 to form a seal therebetween, e.g., by means of an interference fit. At least one raised ring 46 extending a short radial distance outward from the outer surface of the cylindrical sidewall 42 may be used to provide the desired fit and sealing properties between the seal member 40 and the base 20. In the embodiment shown, two such rings 46 are used, however, any other suitable number of rings may be provided. Thus, when the seal member 40 is installed on the base 20, air is prevented from entering the interior of the base 20 due to contact between the outer surface of the sidewall 42 and the inner surface of the base 20. Additional sealing may be provided by contact between the lower surface of the annular rim 43 and the upper edge 24 of the base 20.

[0013] As shown in Figs. 1, 3 and 11-14, the circular flange 45 of the seal member 40 has an inner surface that contacts an outer surface of the downwardly extending ring 34 of the cap 30. In certain embodiments, at least one raised ring 48 extending radially inward from the inner surface of the flange 45 may be used to provide a desired fit between the seal member 40 and the annular ring 34 of the cap 30. Contact between the inner edge of the circular flange 45 or the raised ring 48 and the outer diameter of the downwardly extending ring 34 retains the seal member 40 on the cap 30 when the cap 30 is initially installed on the base 20 during production. Thus, after the container base 20 has been filled with solder paste, a single operation is required to mount the seal member 40 and cap 30 together as a unit on the base 20. In the

embodiment shown, the downwardly extending ring 34 of the cap 30 is beveled 35 in order to facilitate initial mounting of the seal member 40 on the cap 30.

[0014] The base 20, cap 30 and seal member 40 may be made of any suitable materials such as polyethylene, polypropylene or the like. For example, the components may be made of polyethylene. In one embodiment, the base 20 and cap 30 are made of high density polyethylene, while the seal member 40 is made of low density polyethylene. If a piston seal 50 is used, it may be made of polyethylene, e.g., low density polyethylene.

[0015] In one embodiment, the dimensions of the rim 44, flange 45 and raised ring 48, as well as the dimensions of the downwardly extending ring 34, are selected such that a slight interference fit or press fit is provided, e.g., a slight amount of outward radial deformation of the flange 45 and/or inward radial deformation of the ring 34 may occur when the seal member 40 is installed on the cap 30. Such a fit or contact holds the seal member 40 in place on the cap 30 until the cap 30 is initially installed on the base 20. Similarly, the dimensions of the outer diameter of the seal sidewall 42 or raised ring(s) 46 and the inner diameter of the base 20 are selected such that sufficient contact or interference fit is provided between the contact surfaces of the base 20 and seal member 40 in order to prevent air from entering the interior of the base 20, while allowing the seal member 40 to be removed from the base 20 by hand without undue force. The degree of contact or interference fit between the respective parts may be selected by routine experimentation by those skilled in the art.

[0016] In accordance with an embodiment of the invention, the force necessary to remove the seal member 40 from the cap 30 due to the contact between the flange 45 and ring 34 is less than the force necessary to remove the seal member 40 from the base 20 due to contact between the outer surface of the seal sidewall 42 or raised ring(s) 46 and the inner surface of the base 20. In this manner, during initial filling and production of the container assembly 10, the cap 30 and seal member 40 may be installed on the base 20 as a single unit without the necessity of extra production steps conventionally required for separately installing seals and caps on standard containers. However, when the container assembly 10 is first opened by a user by removing the cap 30 from the base 20, the seal member 40 disengages from the cap 30 and remains secured to the base 20 due to the contact between the sidewall 42 or raised ring(s) 46 of the cap and the inside of the base 20. When the seal member 40 is subsequently removed from the base 20 by the user, it can optionally be pressed on to the cap 30 for convenience or safekeeping, in which case the seal member 40 will be automatically reinstalled on the base 20 when the cap 30 is secured to the base 20.

[0017] In addition to allowing the cap 30 and seal member 40 to be installed on the base 20 together as a single unit during production, the radially inwardly extending rim 44 of the seal member 40 provides a finger grip for re-

removal of the seal member 40 from the base 20. Since the outer surface of the seal sidewall 42 or raised ring(s) 46 press against the inner surface of the base 20, a certain amount of force is required to remove the seal member 40 from the base 20, and the radially inwardly extending rim 44 provides a gripping surface to facilitate removal of the seal member 40 against such force.

[0018] For purposes of this detailed description, it is to be understood that the invention may assume various alternative variations except where expressly specified to the contrary. It will be readily appreciated by those skilled in the art that modifications may be made to the invention without departing from the concepts disclosed in the foregoing description. Such modifications are to be considered as included within the following claims unless the claims, by their language, expressly state otherwise. Accordingly, the particular embodiments described in detail herein are illustrative only and are not limiting to the scope of the invention which is to be given the full breadth of the appended claims.

Claims

1. A container, cap and seal assembly comprising:

a container base (20) having an internal volume; a cap (30) movable from an open position to a closed position on the container base; and a seal member (40) having a sealing surface engagable with a surface of the container base to thereby provide a seal for the internal volume of the container base, wherein the seal member is temporarily held on the cap when the cap is initially moved from the open position to the closed position and wherein the seal member is temporarily held on the cap by pressing a portion of the seal member against a portion of the cap,

characterized in that the seal member comprises a radially inwardly extending rim (44), the cap comprises a downwardly extending annular ring (34), and the seal member is temporarily held on the cap by contact between the radially inwardly extending rim and the downwardly extending annular ring.

2. The container, cap and seal assembly of Claim 1, wherein the seal member comprises a generally cylindrical sidewall (42) and the radially inwardly extending rim comprises a generally conical portion (44) connected to the sidewall and a radially inwardly extending circular flange in contact with the downwardly extending annular ring (34) of the cap, the radially inwardly extending circular flange preferably including a raised ring (48) in contact with the downwardly extending annular ring.

3. The container, cap and seal assembly of Claim 1,

wherein the seal member comprises a circular outer surface contacting a generally cylindrical inner surface of the container base to provide the seal.

4. The container, cap and seal assembly of Claim 3, wherein the outer surface of the seal member is generally cylindrical.

5. The container, cap and seal assembly of Claim 3, wherein the outer surface of the seal member comprises at least one raised ring (46) contacting the inner surface of the container base.

6. The container, cap and seal assembly of Claim 3, wherein the seal member further comprises a radially outwardly extending flange (43) having a surface contacting an upper edge of the container base.

7. The container, cap and seal assembly of Claim 1, wherein the container base and cap comprise engagable threads (32) for securing the cap in the closed position.

8. The container, cap and seal assembly of Claim 7, wherein the engagable threads are quarter-turn threads.

9. The container, cap and seal assembly of Claim 7, further comprising engagable tactile stop members (26, 36) on the container base and cap that engage each other when the cap is moved to the closed position, said engagable tactile stop members preferably opposing radially extending ridges.

10. A cap and seal assembly for a container comprising:

a cap (30) comprising at least one thread (32) engagable with a base (20) of the container; and a seal member (40) held on the cap,

wherein the cap and seal member are structured and arranged to temporarily hold the seal member on the cap until the cap is secured on the base of the container, and wherein the seal member is temporarily held on the cap by pressing a portion of the seal member against a portion of the cap, **characterized in that** the seal member comprises a radially inwardly extending rim (44), the cap comprises a downwardly extending annular ring (34), and the seal member is temporarily held on the cap by contact between the radially inwardly extending rim and the downwardly extending annular ring.

11. A method of sealing a container comprising:

at least partially filling a container base (20) with a flowable material; and installing a cap (30) and seal member (40) to-

gether onto the container base, wherein the cap and seal member are structured and arranged to disengage from each other when the cap is subsequently removed from the container base, and wherein the seal member is temporarily held on the cap by pressing a portion of the seal member against a portion of the cap, **characterized in that** the seal member comprises a radially inwardly extending rim (44), the cap comprises a downwardly extending annular ring (34), and the seal member is temporarily held on the cap by contact between the radially inwardly extending rim and the downwardly extending annular ring.

12. The method of Claim 11, wherein the seal member is removable by hand from the container base after the cap is removed.
13. The method of Claim 12, wherein the seal member can be reinstalled on the container base after it has been removed from the container base.
14. The method of Claim 12, wherein the seal member can be reengaged on the cap after the cap has been removed from the container base.
15. The method of Claim 11, wherein the flowable material comprises a paste, said paste preferably comprising solder paste.

Patentansprüche

1. Eine Behälter-, Deckel- und Dichtungsanordnung, umfassend:

ein Behälterunterteil (20) mit einem inneren Volumen;
 einen Deckel (30), welcher auf dem Behälterunterteil von einer geöffneten Position in eine geschlossene Position bewegt werden kann; und
 ein Dichtungselement (40) mit einer dichtenden Oberfläche, welche mit einer Oberfläche des Behälterunterteils verbunden werden kann, um dadurch eine Abdichtung für das innere Volumen des Behälterunterteils bereitzustellen, wobei das Dichtungselement temporär an dem Deckel gehalten wird, wenn der Deckel zu Beginn von der geöffneten Position in die geschlossene Position bewegt wird und wobei das Dichtungselement durch Andrücken eines Teils des Dichtungselements gegen einen Teil des Deckels temporär an dem Deckel gehalten wird, **dadurch gekennzeichnet, dass** das Dichtungselement eine sich radial nach innen erstreckende Lippe (44) umfasst, der Deckel einen sich nach unten erstreckenden kreisförmigen

Ring (34) umfasst und das Dichtungselement durch den Kontakt zwischen der sich radial nach innen erstreckenden Lippe und dem sich nach unten erstreckenden kreisförmigen Ring temporär an dem Deckel gehalten wird.

2. Die Behälter-, Deckel- und Dichtungsanordnung gemäß Anspruch 1, in welcher das Dichtungselement eine im Allgemeinen zylindrische Seitenwand (42) umfasst und die sich radial nach innen erstreckende Lippe einen im Allgemeinen konischen Teil (44) umfasst, welcher mit der Seitenwand verbunden ist und einen sich radial nach innen erstreckenden kreisförmigen Flansch in Kontakt mit dem sich nach unten erstreckenden kreisförmigen Ring (34) des Deckels, wobei der sich radial nach innen erstreckende kreisförmige Flansch vorzugsweise einen erhabenen Ring (48) in Kontakt mit dem sich nach unten erstreckenden kreisförmigen Ring umfasst.
3. Die Behälter-, Deckel- und Dichtungsanordnung gemäß Anspruch 1, in welcher das Dichtungselement eine kreisförmige äußere Oberfläche umfasst, welche eine im Allgemeinen zylindrische innere Oberfläche des Behälterunterteils berührt, um die Dichtung bereitzustellen.
4. Die Behälter-, Deckel- und Dichtungsanordnung gemäß Anspruch 3, wobei die äußere Oberfläche des Dichtungselements im Allgemeinen kreisförmig ist.
5. Die Behälter-, Deckel- und Dichtungsanordnung gemäß Anspruch 3, in welcher die äußere Oberfläche des Dichtungselements mindestens einen erhabenen Ring (46) umfasst, welcher die innere Oberfläche des Behälterunterteils berührt.
6. Die Behälter-, Deckel- und Dichtungsanordnung gemäß Anspruch 3, in welcher das Dichtungselement weiterhin einen sich radial nach außen erstreckenden Flansch (43) mit einer Oberfläche, welche eine obere Kante des Behälterunterteils berührt, umfasst.
7. Die Behälter-, Deckel- und Dichtungsanordnung gemäß Anspruch 1, in welcher das Behälterunterteil und der Deckel verbindbare Gewinde (32) umfassen, um den Deckel in der geschlossenen Position zu sichern.
8. Die Behälter-, Deckel- und Dichtungsanordnung gemäß Anspruch 7, in welcher die verbindbaren Gewinde Vierteldrehungsgewinde sind.
9. Die Behälter-, Deckel- und Dichtungsanordnung gemäß Anspruch 7, weiterhin umfassend ineinandergreifbare, ertastbare Stoppelemente (26, 36) an dem Behälterunterteil und dem Deckel, die ineinandergreifen, wenn der Deckel in die geschlossene Position

tion gedreht wird, wobei besagte ineinandergreifbare, ertastbare Stoppelemente vorzugsweise gegenüberliegende, sich radial erstreckende Erhöhungen umfassen.

10. Eine Deckel- und Dichtungsanordnung für einen Behälter, umfassend:

einen Deckel (30), umfassend mindestens ein Gewinde (32), welches mit einem Unterteil (20) des Behälters verbindbar ist, und ein Dichtungselement (40), welches an dem Deckel gehalten wird, wobei der Deckel und das Dichtungselement so ausgebildet und angeordnet sind, dass sie das Dichtungselement temporär an dem Deckel halten, bis der Deckel auf dem Unterteil des Behälters gesichert ist und in welchem das Dichtungselement durch Anpressen eines Teils des Dichtungselements gegen einen Teil des Deckels temporär auf dem Deckel gehalten wird,

dadurch gekennzeichnet, dass das Dichtungselement eine sich radial nach innen erstreckende Lippe (44) umfasst, der Deckel einen sich nach unten erstreckenden kreisförmigen Ring (34) umfasst und das Dichtungselement durch den Kontakt zwischen der sich radial nach innen erstreckenden Lippe und dem sich nach unten erstreckenden kreisförmigen Ring temporär an dem Deckel gehalten wird.

11. Ein Verfahren zum Abdichten eines Behälters, umfassend:

zumindest teilweises Füllen eines Behälterunterteils (20) mit einem fließfähigen Material und Anbringen eines Deckels (30) und eines Dichtungselements (40) gemeinsam auf dem Behälterunterteil, wobei der Deckel und das Dichtungselement so ausgebildet und angeordnet sind, dass sie sich voneinander lösen, wenn der Deckel nachfolgend von dem Behälterunterteil entfernt wird und wobei das Dichtungselement durch Anpressen eines Teils des Dichtungselements gegen einen Teil des Deckels temporär auf dem Deckel gehalten wird,

dadurch gekennzeichnet, dass das Dichtungselement eine sich radial nach innen erstreckende Lippe (44) umfasst, der Deckel einen sich nach unten erstreckenden kreisförmigen Ring (34) umfasst und das Dichtungselement durch den Kontakt zwischen der sich radial nach innen erstreckenden Lippe und dem sich nach unten erstreckenden kreisförmigen Ring temporär an dem Deckel gehalten wird.

12. Das Verfahren gemäß Anspruch 11, in welchem das Dichtungselement per Hand von dem Behälterunter-

teil entfernt werden kann, nachdem der Deckel entfernt wurde.

13. Das Verfahren gemäß Anspruch 12, wobei das Dichtungselement wieder auf dem Behälterunterteil angebracht werden kann, nachdem es von dem Behälterunterteil entfernt worden ist.

14. Das Verfahren gemäß Anspruch 12, wobei das Dichtungselement wieder mit dem Deckel verbunden werden kann, nachdem der Deckel von dem Behälterunterteil entfernt worden ist.

15. Das Verfahren gemäß Anspruch 11, wobei das fließfähige Material eine Paste umfasst, wobei besagte Paste vorzugsweise eine Lötpaste umfasst.

Revendications

1. Ensemble récipient, bouchon et opercule comprenant :

une base de récipient (20) ayant un volume interne ;

un bouchon (30) mobile d'une position ouverte à une position fermée sur la base de récipient ; et un organe d'opercule (40) ayant une surface d'étanchéité pouvant être enclenchée avec une surface de la base de récipient afin de fournir ainsi un opercule pour le volume interne de la base de récipient, dans lequel l'organe d'opercule est temporairement maintenu sur le bouchon lorsque le bouchon est initialement déplacé de la position ouverte à la position fermée et dans lequel l'organe d'opercule est temporairement maintenu sur le bouchon en pressant une portion de l'organe d'opercule contre une portion du bouchon,

caractérisé en ce que l'organe d'étanchéité comprend une bordure s'étendant radialement vers l'intérieur (44), le bouchon comprend une bague annulaire s'étendant vers le bas (34), et l'organe d'opercule est temporairement maintenu sur le bouchon par un contact entre le bord s'étendant radialement vers l'intérieur et la bague annulaire s'étendant vers le bas.

2. Ensemble récipient, bouchon et opercule selon la revendication 1, dans lequel l'organe d'opercule comprend une paroi latérale généralement cylindrique (42) et la bordure s'étendant radialement vers l'intérieur (44) comprend une portion généralement conique raccordée à la paroi latérale et une bride circulaire s'étendant radialement vers l'intérieur en contact avec la bague annulaire s'étendant vers le bas (34) du bouchon, la bride circulaire s'étendant radialement vers l'intérieur comprenant de préféren-

ce une bague surélevée (48) en contact avec la bague annulaire s'étendant vers le bas.

3. Ensemble récipient, bouchon et opercule selon la revendication 1, dans lequel l'organe d'opercule comprend une surface externe circulaire en contact avec une surface interne généralement cylindrique de la base de récipient pour fournir l'opercule. 5
4. Ensemble récipient, bouchon et opercule selon la revendication 3, dans lequel la surface externe de l'organe d'opercule est généralement cylindrique. 10
5. Ensemble récipient, bouchon et opercule selon la revendication 3, dans lequel la surface externe de l'organe d'opercule comprend au moins une bague surélevée (46) en contact avec la surface interne de la base de récipient. 15
6. Ensemble récipient, bouchon et opercule selon la revendication 3, dans lequel l'organe d'opercule comprend en outre une bride s'étendant radialement vers l'extérieur (43) ayant une surface en contact avec un bord supérieur de la base de récipient. 20
7. Ensemble récipient, bouchon et opercule selon la revendication 1, dans lequel la base de récipient et le bouchon comprennent des filetages enclenchables (32) pour arrimer le bouchon dans la position fermée. 25
8. Ensemble récipient, bouchon et opercule selon la revendication 7, dans lequel les filetages enclenchables sont des filetages quart de tour. 30
9. Ensemble récipient, bouchon et opercule selon la revendication 7, comprenant en outre des organes de butée tactiles enclenchables (26, 36) sur la base de récipient et le bouchon qui s'enclenchent les uns les autres lorsque le bouchon est déplacé vers la position fermée, lesdits organes de butée tactiles enclenchables étant de préférence en regard de rainures s'étendant radialement. 35
10. Ensemble bouchon et opercule pour un récipient comprenant : 40
 - un bouchon (30) comprenant au moins un filetage (32) enclenchable avec une base (20) du récipient ; et
 - un organe d'opercule (40) maintenu sur le bouchon, dans lequel les organes de bouchon et d'opercule sont structurés et agencés pour maintenir temporairement l'organe d'opercule sur le bouchon jusqu'à ce le bouchon soit arrimé sur la base du récipient, et dans lequel l'organe d'opercule est temporairement maintenu sur le bou-

chon en pressant une partie de l'organe d'opercule contre une partie du bouchon,

caractérisé en ce que l'organe d'opercule comprend une bordure s'étendant radialement vers l'intérieur (44), le bouchon comprenant une bague annulaire s'étendant vers le bas (34), et l'organe d'opercule étant temporairement maintenu sur le bouchon par contact entre la bordure s'étendant radialement vers l'intérieur et la bague annulaire s'étendant vers le bas.

11. Procédé d'étanchéification d'un récipient comprenant :

le remplissage au moins partiel d'une base de récipient (20) avec un matériau coulant ; et l'installation d'un bouchon (30) et d'un organe d'opercule (40) ensemble sur la base du récipient, où le bouchon et l'organe d'opercule sont structurés et agencés pour se désenclencher l'un de l'autre lorsque le bouchon est ensuite enlevé de la base de récipient, et dans lequel l'organe d'opercule est temporairement maintenu sur le bouchon en pressant une partie de l'organe d'opercule contre une partie du bouchon,

caractérisé en ce que l'organe d'opercule comprend une bordure s'étendant radialement vers l'intérieur (44), le bouchon comprenant une bague annulaire s'étendant vers le bas (34), et l'organe d'opercule étant temporairement maintenu sur le bouchon par contact entre la bordure s'étendant radialement vers l'intérieur et la bague annulaire s'étendant vers le bas.

12. Procédé selon la revendication 11, dans lequel l'organe d'opercule peut être enlevé à la main de la base de récipient après que le bouchon est enlevé. 35
13. Procédé selon la revendication 12, dans lequel l'organe d'opercule peut être réinstallé sur la base de récipient après qu'il a été enlevé de la base de récipient. 40
14. Procédé selon la revendication 12, dans lequel l'organe d'opercule peut être réenclenché sur le bouchon après que le bouchon a été enlevé de la base de récipient. 45
15. Procédé selon la revendication 11, dans lequel le matériau coulant comprend une pâte, ladite pâte comprenant de préférence une pâte à braser. 50

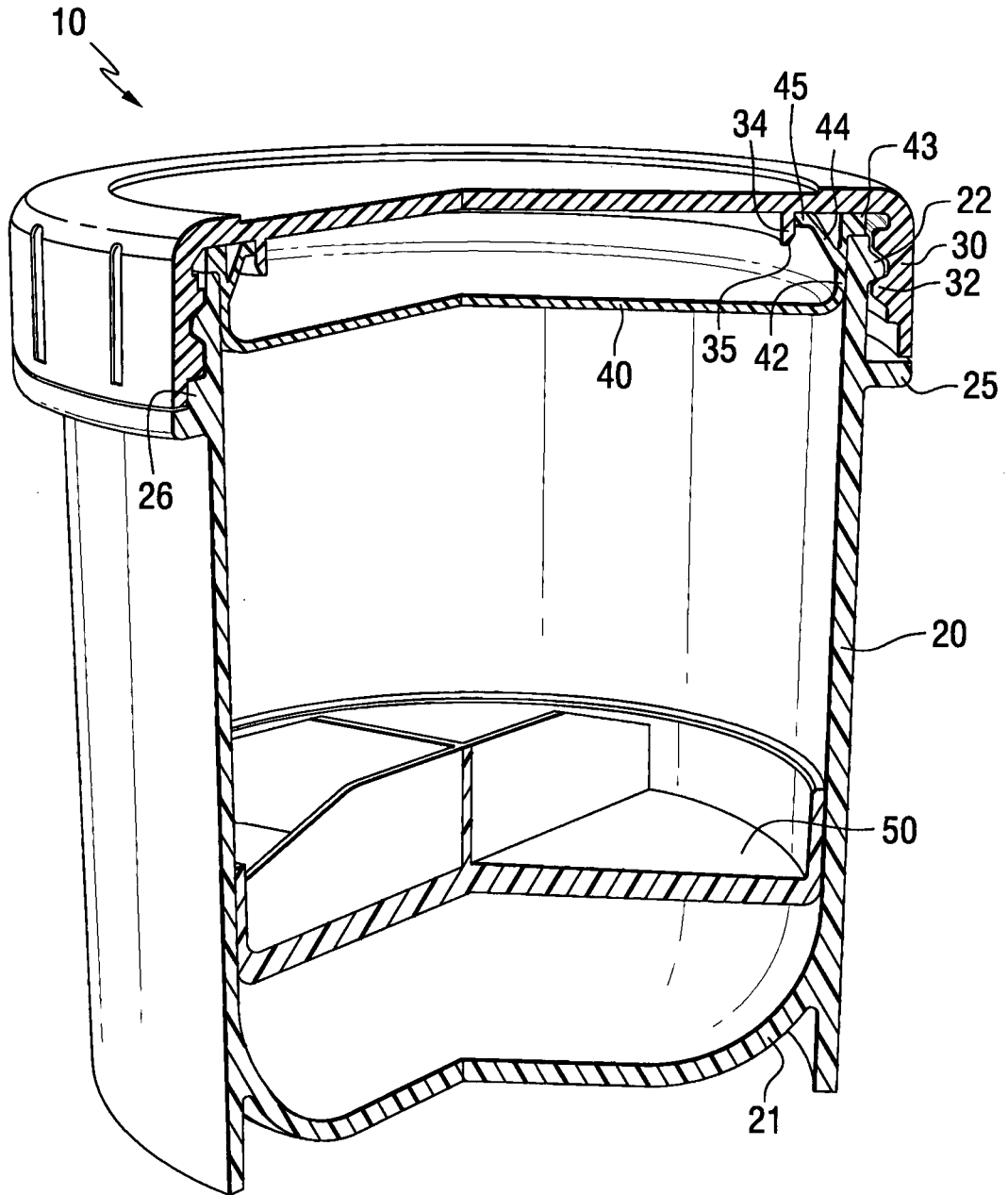

FIG. 1

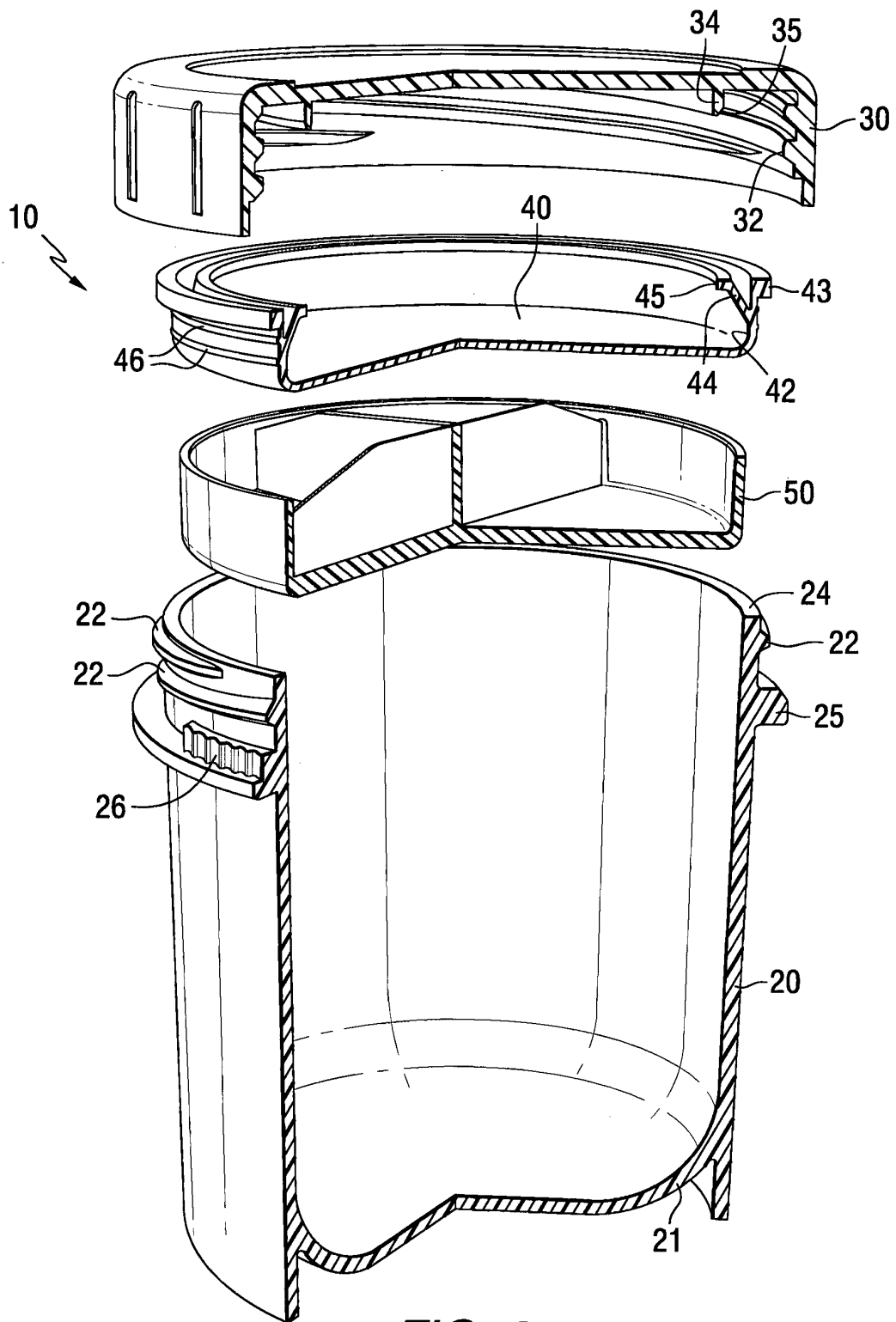

FIG. 2

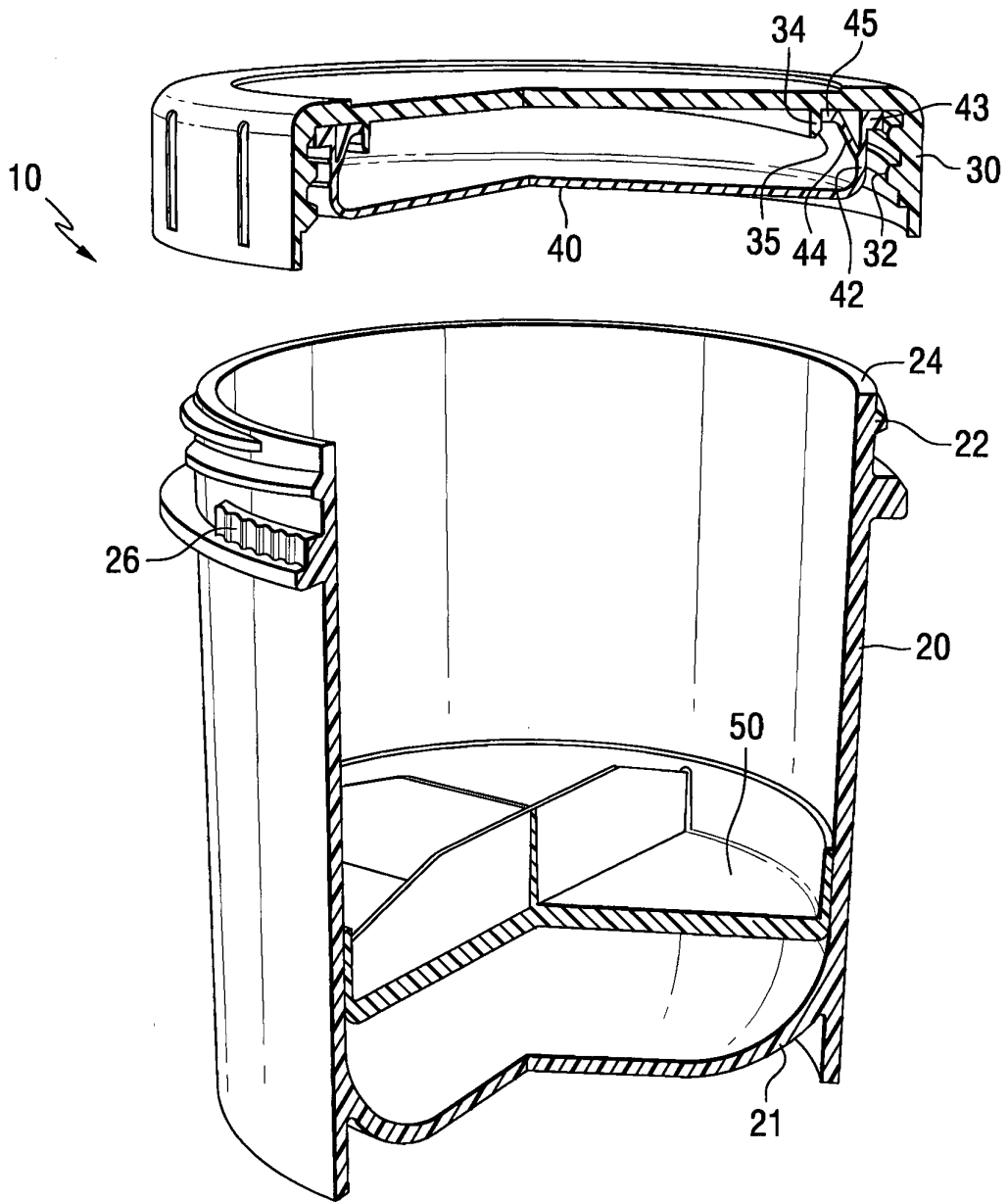

FIG. 3

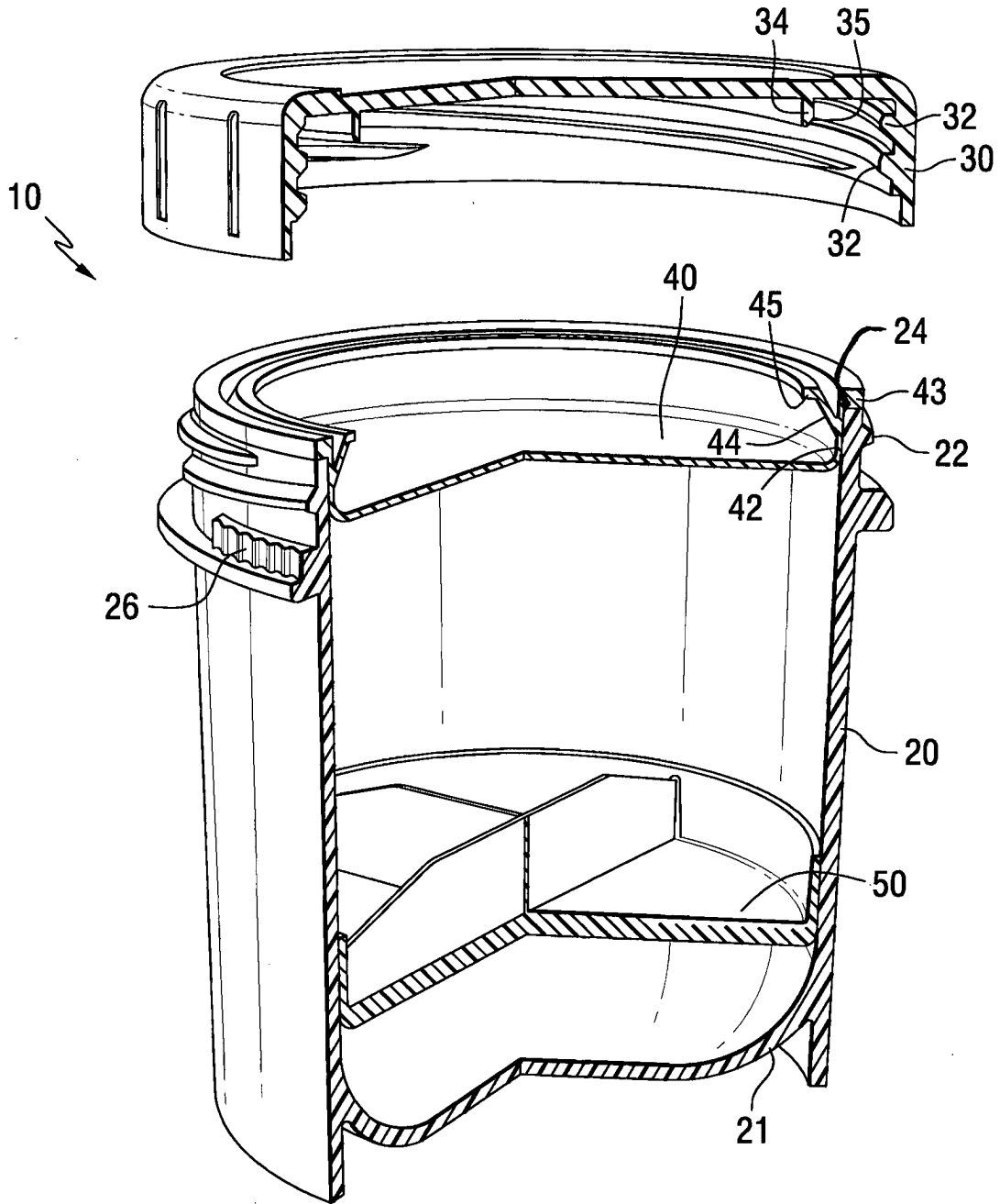

FIG. 4

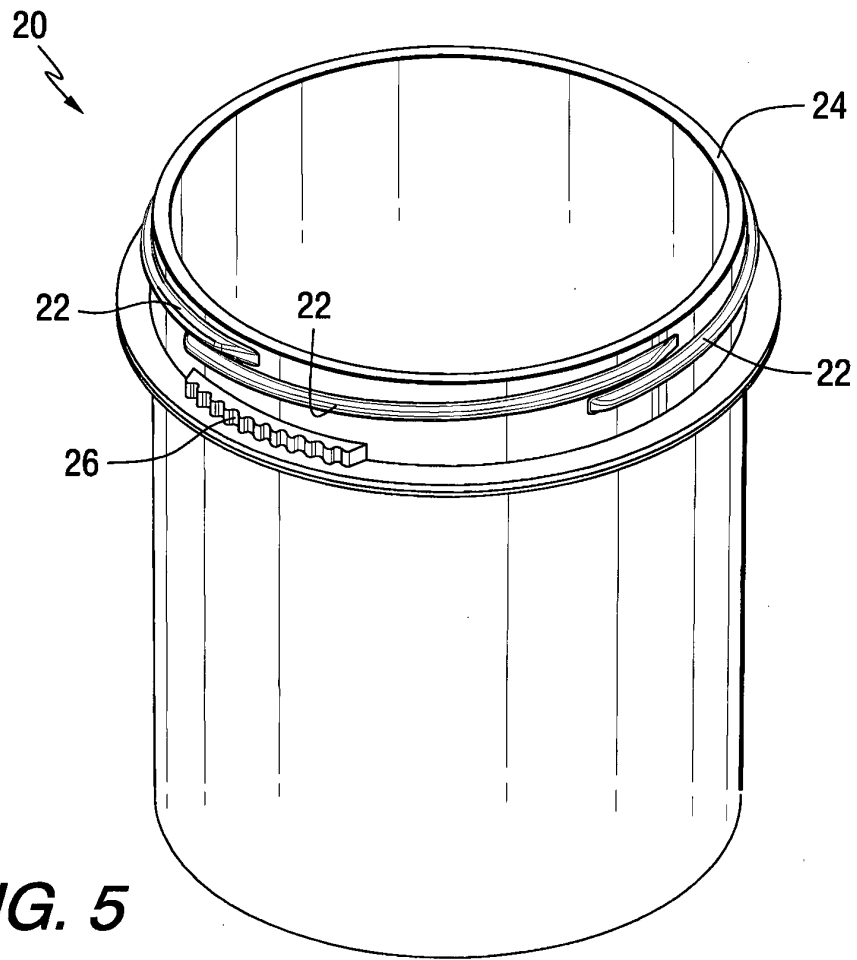

FIG. 5

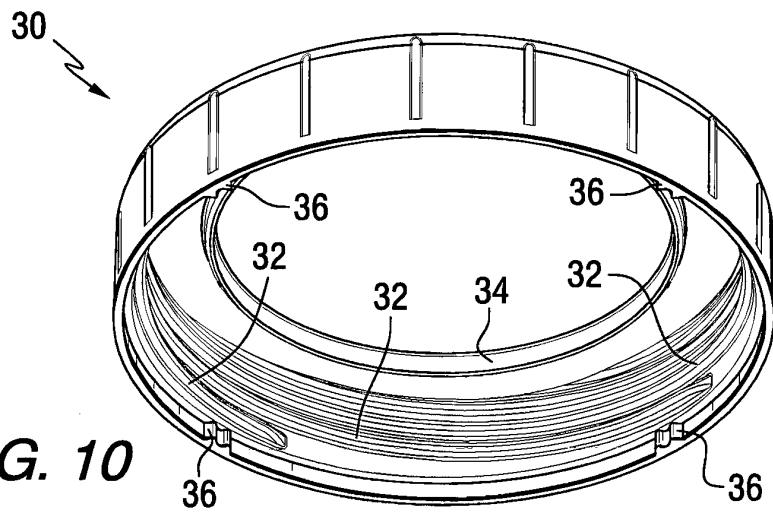

FIG. 10

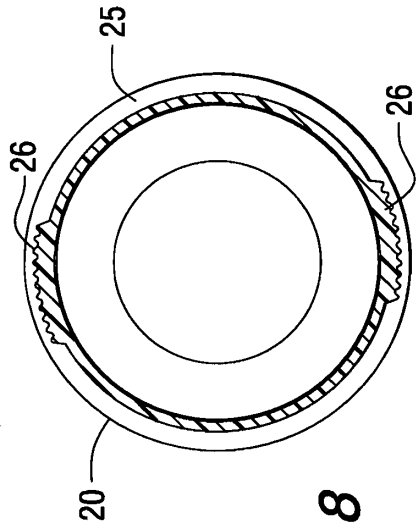

FIG. 8

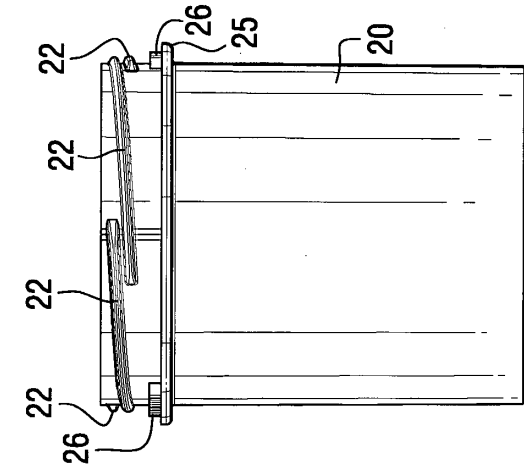

FIG. 6

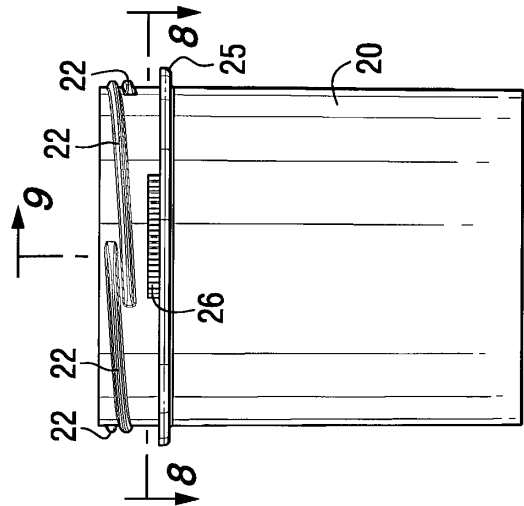

FIG. 7

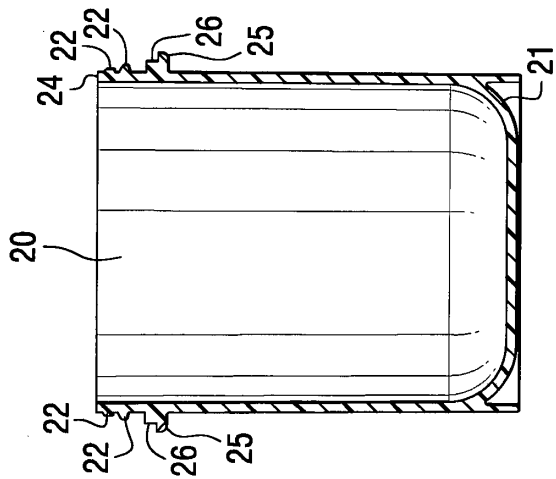

FIG. 9

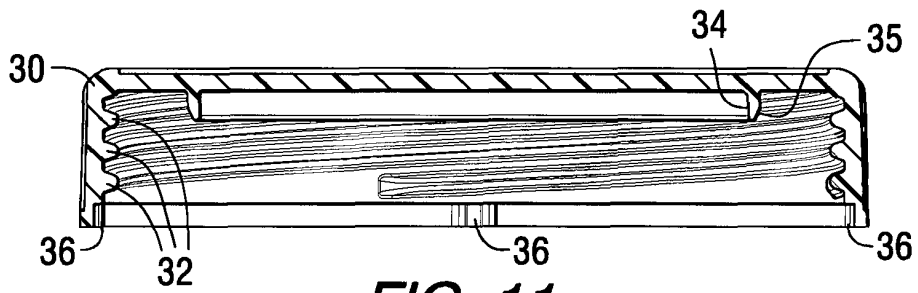

FIG. 11

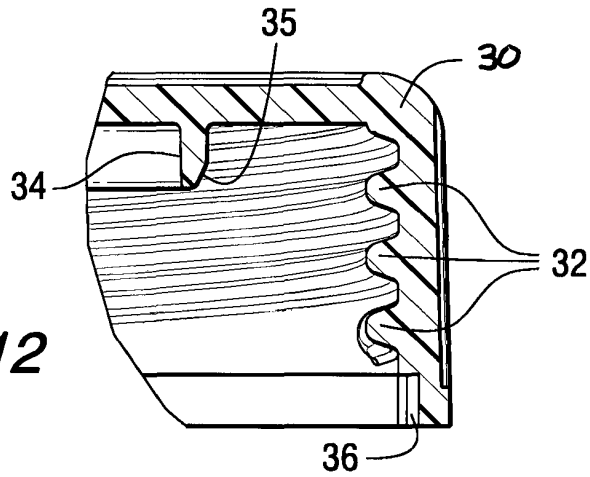

FIG. 12

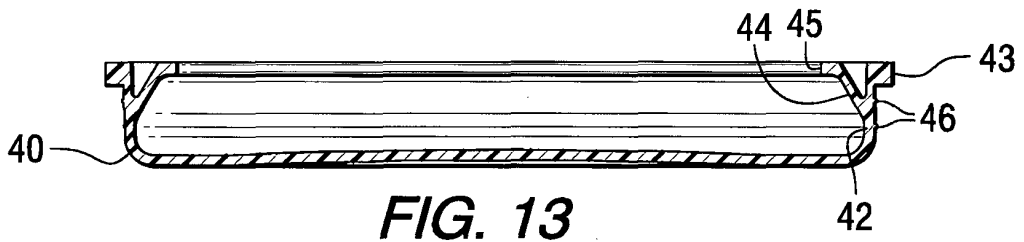

FIG. 13

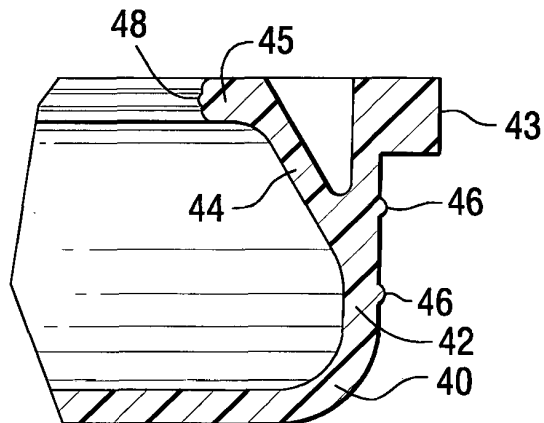

FIG. 14