

M. L. EDWARDS.
Hollow Augers.

No. 133,573.

Patented Dec. 3, 1872.

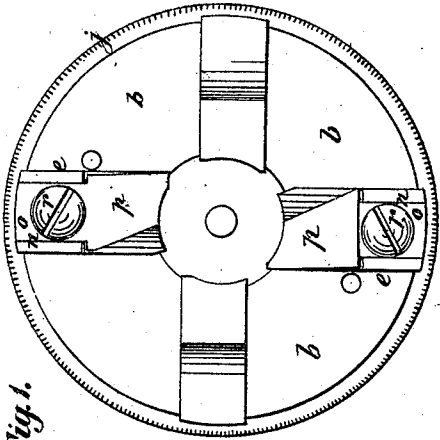

Fig. 1.

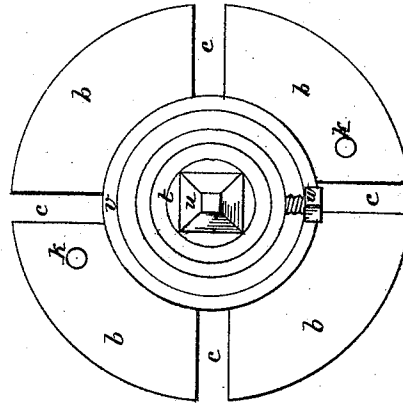

Fig. 3.

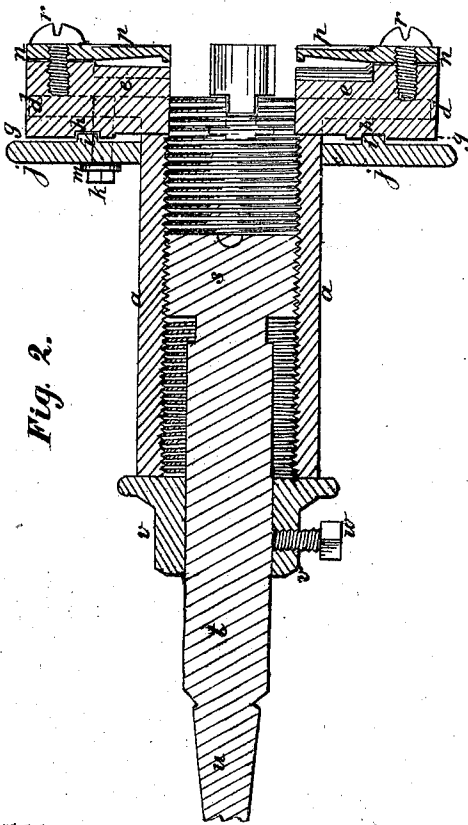

Fig. 2.

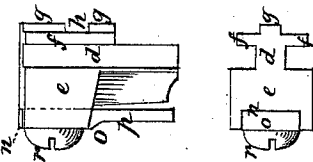

Fig. 5.

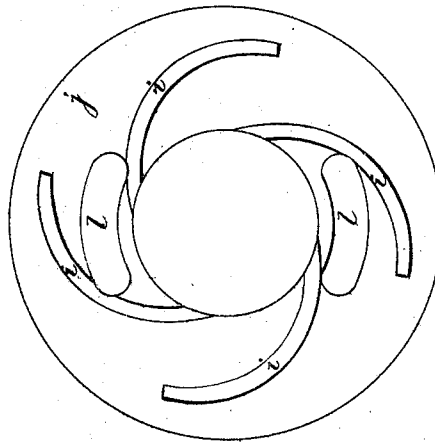

Fig. 4.

Witnesses:

A. O. W. Johnson
Alex. S. O. Klaucke.

Inventor:

Martin L. Edwards

by

Edward B. Stanton,
his Attorney.

UNITED STATES PATENT OFFICE.

MARTIN L. EDWARDS, OF SALEM, OHIO.

IMPROVEMENT IN HOLLOW AUGERS.

Specification forming part of Letters Patent No. 133,573, dated December 3, 1872.

To all whom it may concern:

Be it known that I, MARTIN L. EDWARDS, of Salem, in the county of Columbiana and State of Ohio, have invented new and useful Improvements in Hollow Augers for Cutting Tenons, of which the following is a specification:

My invention has for its object the cutting of tenons of different diameters on wood by a tool, the knives of which are adjustable concentrically to cut a larger or smaller tenon; and my said invention consists in the construction, arrangement, and combination of the several parts of the said tool, as hereinafter more fully described.

In the accompanying drawing, Figure 1 represents a front elevation or face view of my improved hollow auger for cutting tenons; Fig. 2 represents a longitudinal section of the same, the line of section passing through the cutters in the head-flange; Fig. 3 represents a view of the rear side of the head-flange, the plate for adjusting the knives and guides being removed; Fig. 4 represents an inside face view of the plate which adjusts the knives and guides; and Fig. 5, a side and end view of one of the cutters.

The hollow auger for cutting tenons consists of a hollow shank, *a*, provided with an internal screw-thread, and at one end with a head consisting of a flange, *b*, which flange is provided with four equidistant slots, *c*, extending from the central opening of the shank *a* to the periphery of the flange *b*. These slots are not exactly radial—that is to say, each two opposite slots are not in the same diametrical line—their inner ends not being exactly opposite each other; but each slot has the same relative position to the center as the others. In these slots *c* the longitudinal tongues *d*, formed on the inner side of sliding blocks *e*, have a free movement toward and from the center, being prevented from moving out of the slots *c* by means of short plates *f* extending from the outer end of the tongues *d* inwardly to about half their lengths, and which bear against the rear side of the head-flange *b*. On the outside of the plates *f* tongues *g* are formed, which have concentric grooves or ways *h* cut across them to receive corresponding concentric ribs *i* formed on the inner surface of an adjusting-plate, *j*. This plate *j* is provided with a cen-

tral opening to admit of its being passed over the shank *a*, on which it may be moved at pleasure. The ribs *i* on its inner surface are eccentrically curved or inclined, and each one bears the same relative position to its corresponding groove *h* on the tongue *g*, and to the center of the hollow shank *a*, so that if the plate *j* is turned one way or the other its ribs *i*, operating the blocks *e* through the grooves *h* in their tongues *g*, will force the sliding blocks *e* either toward or from the center in their slots *c* to perfectly equal distances, and the inner ends of the blocks will therefore be always concentric and equidistant in whatever position they may have been placed by the plate *j*. This adjusting-plate *j* is held to the flange *b*, and in any desired position relatively to the distance of the sliding blocks *e* from the center by means of set-screws *k*, which pass through curved concentric slots *l*, formed at opposite sides in the plate *j*, and which set-screws pass into screw-holes formed in the flange *b*, shoulders *m* formed on them near their outer ends bearing against the outer face of the plate *j* and holding it firmly in place. The inner ends of the four sliding blocks *e* are cut out to conform to the periphery of the central opening of the shank *a*, and two of them on opposite sides have slots *n* cut in the surface of their outer ends, in which slots the square shanks *o* of the cutting-knives *p* fit snugly, screws *r* passing through said shanks into the sliding blocks, rigidly securing the knives in their respective blocks *e*. A portion of the sliding blocks *e* under the knives *p* is cut away to leave a space for the free passage of chips, which thereby will be prevented from clogging the knives. Into the hollow shank *a*, from its near end, screws the screw-head *s* of the mandrel *t*, which mandrel is provided with a square end, *u*, by means of which it may be attached to a lathe or other machine for revolving the tool. By means of this mandrel the length of the tenon is determined; for when it is secured into the shank *a* to such a distance that the distance from the surface of its screw-head *s* to the edge of the knives *p* is equal to the desired length of the tenon to be cut, the mandrel is kept in such position by means of a shouldered sleeve, *v*, which has a free movement on the smooth, round shank of the mandrel, and which is then moved on said shank until its shoulder firmly

bears against the end of the hollow shank *a*, and secured by a set-screw, *w*. When the end of the tenon which is being cut reaches the surface of the said screw-head *s* of the mandrel the tool can cut no further, and thus the length of the tenon can be determined and regulated by the mandrel *t*.

My improved tenon-cutter can be made of any desired size, and may be applied to machines operated either by hand or power.

The knives, which are rigidly held in the sliding blocks *e*, may be readily adjusted for any

size of tenon by means of the plate *j*, which is released or held in position merely by the set-screws *k*, thus rendering the tool simple, and easily handled and adjusted.

Having described my invention, I claim—

The hollow auger for cutting tenons, all its parts being arranged and constructed as described.

MARTIN L. EDWARDS.

Witnesses:

B. S. AMBLER,

PETER AMBLER.