

(No Model.)

E. J. WOOD.

REDUCING PRESSURE VALVE AND REGULATOR.

No. 527,575.

Patented Oct. 16, 1894.

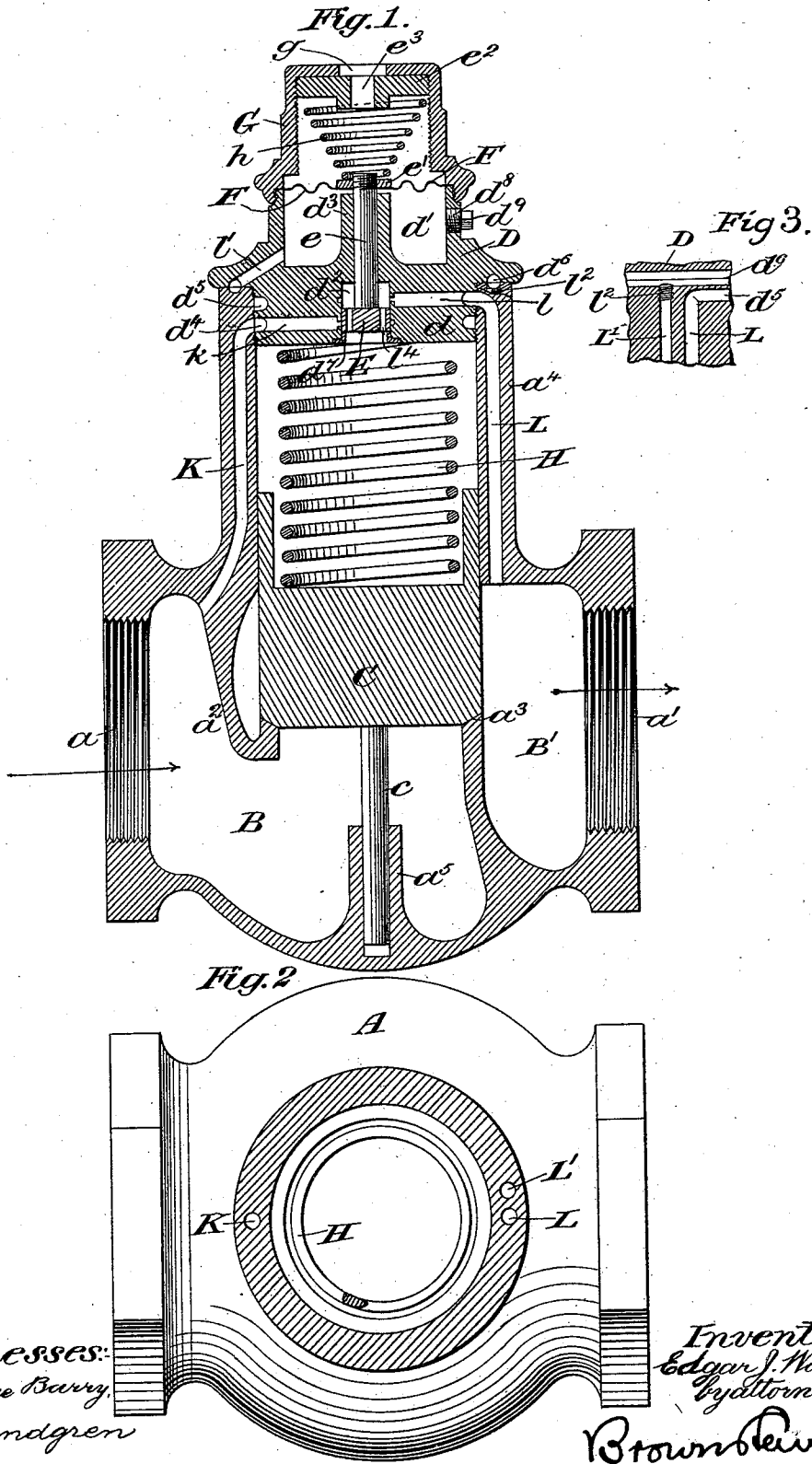

Witnesses:
George Barry,
O. Sundgren

Inventor,
Edgar J. Wood
By Attorneys
Brown & Howard

UNITED STATES PATENT OFFICE.

EDGAR J. WOOD, OF BROOKLYN, NEW YORK.

REDUCING-PRESSURE VALVE AND REGULATOR.

SPECIFICATION forming part of Letters Patent No. 527,575, dated October 16, 1894.

Application filed February 13, 1894. Serial No. 500,065. (No model.)

To all whom it may concern:

Be it known that I, EDGAR J. WOOD, of Brooklyn, in the county of Kings and State of New York, have invented a new and useful
5 Improvement in Reducing-Pressure Valves and Pump-Regulators, of which the following is a specification.

My invention relates to an improvement in reducing pressure valves and pump regulators in which provision is made for transmitting an abnormal pressure on the low pressure side of the valve to a diaphragm which controls a valve for the admission of pressure from the high pressure side to the back of
15 the main valve, to throw the same toward its seat and thereby reduce the pressure on the low pressure side.

A practical embodiment of my invention is represented in the accompanying drawings,
20 in which—

Figure 1 is a view of the valve in longitudinal section, the wall being partially broken away in proximity to the head piece to show the upper portion of the second passageway.

25 Fig. 2 is a view of the same in transverse section, through line x, x of Fig. 1. Fig. 3 is a detail sectional view.

My invention contemplates a valve which may be utilized either in connection with the supply of a fluid under pressure as simply a reducing valve and also with a pump for the purpose of regulating the pressure in the compression chamber.

A pipe section A, provided—as is usual—at its opposite ends with screw threaded sockets a and a' for the purpose of connecting therewith transmitting pipes, is provided with an interior diaphragm a^2 for separating the high pressure chamber B from the low pressure chamber B'. The diaphragm a^2 is provided with an opening around which is formed a valve seat a^3 on which a main valve C is adapted to seat. The section A is provided with an extended hollow neck a^4 within
45 which the valve C is fitted to reciprocate toward and away from its seat a^3 .

The valve C is provided at its face with an extended guide stem c adapted to fit and slide in a socket a^5 projecting inwardly from the
50 wall of the section A.

A head piece D is provided with a screw

threaded extension d adapted to screw into the outer end of the neck a^4 and form a closure for the same. The said head piece is also provided with a hollow outer portion d' forming a chamber for the reception of the fluid
55 which is to operate the valve controlling diaphragm, and in its inner face the said head piece D is provided with a socket or chamber d^2 for the reception of the auxiliary piston
60 valve E. The stem e of the valve E extends outwardly through the bore in a central bearing d^3 of the head piece and through the diaphragm F with which it is connected by a nut e' screwed onto the threaded outer end of the
65 stem.

The diaphragm F is held in position at the outer end of the head piece D over the chamber D' by means of a cap piece G screwed onto the outer end of the head piece.
70

The auxiliary valve E is returned to its normal position (shown in Fig. 1) by means of a spring h inserted between the nut e' and the adjusting end e^2 , having a screw threaded engagement with the interior of the cap piece
75 G and, for purposes of increasing or diminishing the tension of the spring h upon the valve E, I leave an opening g in the top of the cap piece in order that a tool may be inserted into a recess e^3 in the end e^2 for turning it toward
80 or away from the end e' , according as it is desired to increase or diminish the tension.

The valve C is returned toward its seat by means of a spring H inserted between its back and the inner end of the head piece D.
85

A small conduit K leads from the high pressure chamber B along, up within the wall of the neck a^4 to a point opposite an annular groove d^4 around the exterior of the screw threaded extension d of the head piece, which
90 groove d^4 connects, by a passageway k , with the socket or chamber d^2 in which the auxiliary valve E reciprocates.

Passageways L and L' extend from the low pressure chamber B' along within the wall of the neck a^4 , the former communicating with an annular groove d^5 on the exterior of the extension d which groove connects, by a passageway l , with the socket or chamber d^2 and the latter L' connects with a groove d^6 on the
95 under side of the flange of the head piece D which extends over the end of the neck a^4 ,
100

said groove d^6 connecting by a passageway l' with the interior of the chamber d' beneath the diaphragm.

The auxiliary valve E is provided with 5 ports l^4 through it and its movement within the socket or chamber d^2 is such that when it is in its normal position, (as shown in Fig. 1) it will close communication between the chamber at the back of the main valve C and 10 the passageway K leading to the high pressure chamber, but will leave free communication from the chamber at the back of the main valve, through its ports l^4 , to the pas- 15 sageway L, leading to the low pressure chamber. When the said auxiliary valve E, under pressure within the chamber d' , is lifted by means of the diaphragm F so as to open communication between the chamber back of the 20 main valve C and the high pressure chamber B, it will—at the same time—close the communication between said chamber back of the main valve C and the passageway L leading to the low pressure chamber B'. The valve E 25 is limited in its downward stroke by means of an annular seat d^7 , fixed at the open end of the chamber d^2 .

I provide the passageway L' at the outer end of the neck a^4 with an internal screw threaded portion l^2 for the purpose of receiving 30 a screw plug to stop the channel L' when the valve is to be employed as a pump regulator or governor and I further provide the head piece D with a screw threaded opening d^8 for receiving a screw plug d^9 , so that when 35 used as simply a reducing valve, the opening d^8 may be closed and when used as a pump governor it may be opened for the purpose of connecting the chamber d' beneath the diaphragm with the compression chamber of the 40 pump instead of directly with the low pressure chamber B'.

The screw plug may be inserted into and removed from the screw threaded portion 45 l^2 of the channel L' by removing the head piece D.

In operation, suppose the valve to be employed as simply a reducing pressure valve, the plug d^9 closing the opening d^8 and the plug for closing the passageway L' removed. 50 Whenever the pressure upon the low pressure side of the main valve exceeds the predetermined limit, its pressure underneath the diaphragm F, communicated to the chamber d' through the passageway L' and l' will lift the 55 diaphragm F and with it the auxiliary valve E, opening communication through the passageway K and the high pressure side of the main valve to the chamber at the back of the main valve and at the same time close the 60 communication between the chamber at the back of the main valve and the passageway L leading to the low pressure side of the valve. The pressure upon the opposite sides of the main valve C will thereby become balanced 65 and the valve C will be thrown by its own weight or by the spring H, or by both, toward its seat shutting off the supply of fluid and

thereby reducing the pressure on the low pressure side. As soon as this pressure is reduced to the predetermined limit, the dia- 70 phragm F will return to its normal position, carrying with it the auxiliary valve E and thereby closing communication between the chamber at the back of the main valve C and the high pressure side and permitting the ex- 75 haust of the fluid at the back of the main valve out through the passageway L to the low pressure side.

It will be observed that the auxiliary valve E, by means of its ports l^4 , is at all times bal- 80 anced—so far as pressure from within the chamber at the back of the valve C is concerned.

If it be desired to use the valve as a pump governor, the passageway L' will be closed by 85 the plug inserted in the screw-threaded portion l^2 and the chamber d' beneath the diaphragm will be placed in communication with the compression chamber of the pump by removing the plug d^9 . The operation of the 90 valve will be in all respects quite similar under these circumstances to that hereinbefore described, the diaphragm F being under the control of the fluid in the compression chamber on the low pressure side of the main valve 95 and serve, when it exceeds the predetermined limit, to open communication between the back of the main valve and the high pressure side and thereby reduce the supply of actuating fluid. 100

It is obvious that slight changes might be resorted to in the construction and arrangement of the several parts herein described without departing from the spirit and scope 105 of my invention. Hence I do not wish to limit myself strictly to the structure herein set forth, but

What I claim is—

1. In combination, a casing, a main valve for controlling the passage of a fluid under 110 pressure from a supply to the point where it is to be utilized, an auxiliary valve seated in a chamber in communication with the space back of the main valve, a flexible diaphragm for transmitting motion to the auxiliary valve, 115 a passageway leading from the high pressure chamber in which the auxiliary valve moves, passageways leading from the opposite or low pressure side of the main valve, one to the said auxiliary valve chamber and one to the 120 diaphragm chamber, the movement of the auxiliary valve in one direction serving to open the high pressure passageway and close the low pressure passageway and the movement of the valve in the opposite direction 125 serving to close the high pressure passageway and open the low pressure passageway, substantially as set forth.

2. In combination, a casing, a main valve for controlling the transmission of a fluid under 130 pressure, an auxiliary valve provided with a port extending through from its face to its back and seated in a chamber in communication with the back of the main valve,

a flexible diaphragm for transmitting motion to the auxiliary valve, independent passageways leading from the low pressure side of the main valve along the wall of the casing, the one to the diaphragm chamber and the other to the auxiliary valve chamber, a third passageway leading from the high pressure side of the main valve along the wall of the valve casing to the said auxiliary valve chamber, the movement of the auxiliary valve in one direction serving to open the high pressure passageway and close the low pressure passageway and its movement in the opposite direction serving to open the low pressure passageway and close the high pressure passageway, substantially as set forth.

3. The valve casing, provided with a diaphragm chamber, an auxiliary valve chamber, a main valve chamber, a partition provided with an opening for the passage of a fluid under pressure, passageways connecting the interior of the casing upon one side of the partition with the auxiliary valve chamber and with the diaphragm chamber, the diaphragm chamber having a second opening through its wall independent of the aforesaid passageway, means for opening and closing either of said passageways, an opening leading to the diaphragm chamber at pleasure, and a passageway leading from the opposite side of the said partition to the auxil-

iary valve chamber, in combination with the main valve, the auxiliary valve, the diaphragm and the actuating springs, substantially as set forth.

4. The combination with the valve casing provided with a partition having an opening for the transmission of fluid under pressure and further provided with a hollow neck, of a head piece provided with an auxiliary valve chamber and adapted to form a closure for the end of the said neck, a cap piece fitted to the top of said head piece, a flexible diaphragm secured between the cap and head pieces, an auxiliary valve seated in the said chamber in the head piece and having its stem connected with the flexible diaphragm, a traveling nut located within the cap piece, a spring interposed between the said nut and the diaphragm, a main valve seated within the hollow neck, a spring inserted between the said valve and head piece, passageways leading from the opposite sides of the partition to the auxiliary valve chamber and a passageway leading from one side of said partition to the diaphragm chamber, substantially as set forth.

EDGAR J. WOOD.

Witnesses:

FREDK. HAYNES,
GEORGE BARRY.