

(No Model.)

C. J. EHBETS.

2 Sheets—Sheet 1.

MAGAZINE FIRE ARM.

No. 343,800.

Patented June 15, 1886.

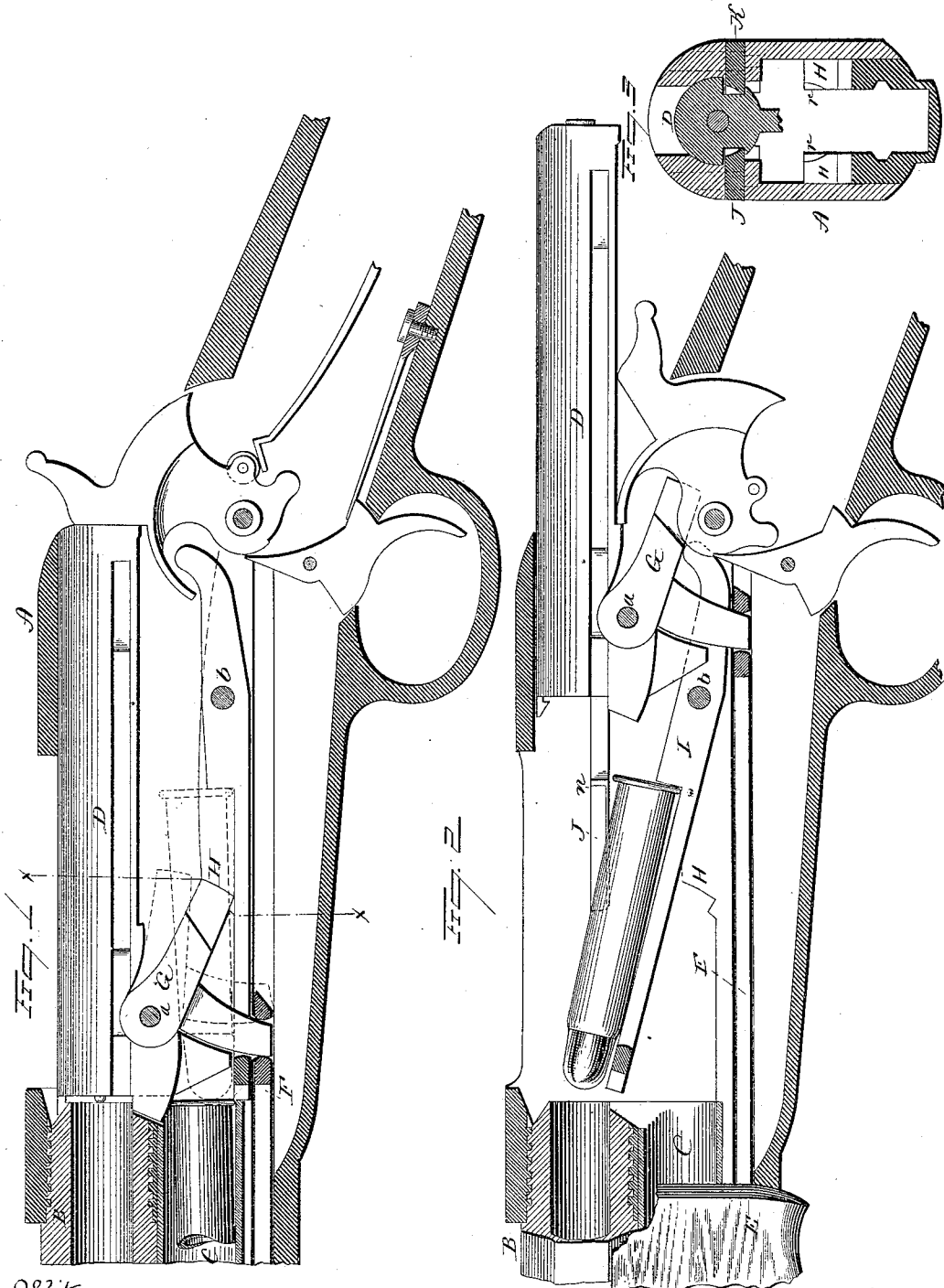

Witnesses.
John H. Shumway
Frederick C. Earle

Carl J. Ehbets.
Inventor.
By Atty.
Frederick C. Earle

(No Model.)

2 Sheets—Sheet 2.

C. J. EHBETS.
MAGAZINE FIRE ARM.

No. 343,800.

Patented June 15, 1886.

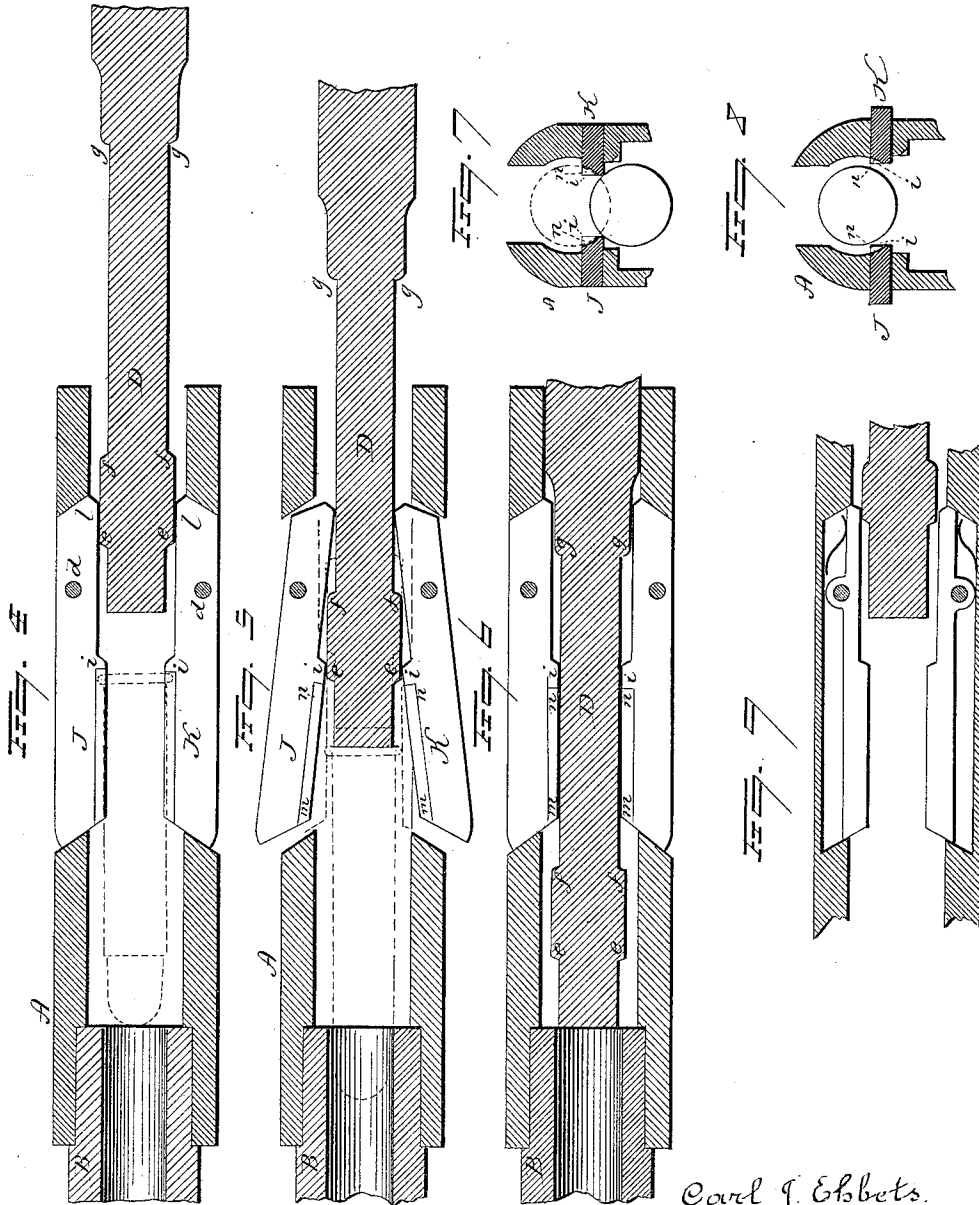

Witnesses.

J. A. Shumway
Fred C. Carl

Carl J. Ehbets.
Inventor.

By *Atty.*

Fred C. Carl

UNITED STATES PATENT OFFICE.

CARL J. EHBETS, OF HARTFORD, CONNECTICUT, ASSIGNOR TO COLTS PATENT FIRE ARMS MANUFACTURING COMPANY, OF SAME PLACE.

MAGAZINE FIRE-ARM.

SPECIFICATION forming part of Letters Patent No. 343,800, dated June 15, 1886.

Application filed April 5, 1886. Serial No. 197,778. (No model.)

To all whom it may concern:

Be it known that I, CARL J. EHBETS, of Hartford, in the county of Hartford and State of Connecticut, have invented a new Improvement in Magazine Fire-Arms; and I do hereby declare the following, when taken in connection with accompanying drawings, and the letters of reference marked thereon, to be a full, clear, and exact description of the same, and which said drawings constitute part of this specification, and represent, in—

Figure 1, a sectional side view showing the parts in the closed position; Fig. 2, the same view showing the parts in the open position, the carrier raised; Fig. 3, a transverse section through Fig. 1 on line $x x$; Figs. 4, 5, and 6, horizontal sectional views to illustrate the operation of the ribs; Fig. 7, a transverse section through the ribs in the closed position, showing the cartridge as below the ribs; Fig. 8, the same section, showing the ribs in the open position and the cartridge as having been raised between them; Fig. 9, a modification.

This invention relates to an improvement in that class of magazine fire-arms in which the magazine is arranged longitudinally beneath the barrel and so as to open into the receiver directly below the barrel, and in which a carrier is hung in the receiver at the rear, and onto which a cartridge may pass from the magazine, and so that as the carrier is turned upward upon its pivot it will present the forward or ball end of the cartridge in line with the barrel, and so that the head will come into the path of the breech-piece as it advances toward the barrel. The cartridge with this class of carrier necessarily stands in an inclined position on the carrier, and after the ball enters the barrel the rear end of the cartridge is brought up into line with the barrel, because of the action of the forward part of the cartridge in the barrel.

To prevent the displacement of the cartridge on the carrier during its rising movement and before it has been entered into the barrel, some device is necessary. In the patent of Elliot, No. 285,020, and on which this invention is an improvement, the device to thus prevent the displacement of the cartridge consists of two longitudinal ribs, one at each side of the carrier, upon the inside, and which extend

forward of the breech-piece, when in its open position, and beyond the head of the cartridge so far as to control the cartridge during the first part of its advance under the forward movement of the breech-piece, but so that the head of the cartridge will escape from the forward end of the ribs when the cartridge has so far entered the barrel that the barrel controls its further movement, and in thus escaping from the end of the ribs the cartridge may rise into the axial line of the barrel. With stationary ribs or guards, as in the Elliot patent, they can extend forward of the breech-piece only to a certain proportion of the length of the cartridge, for so soon as the cartridge has fairly entered in the barrel it must rise from its inclined position beneath the ribs into the horizontal position or axial line of the barrel. With a short cartridge the stationary ribs offer no obstacle to the operation or working of the arm, but in the case of a long cartridge, in order to accomplish their object and properly guard the cartridge while on the carrier, to prevent its accidental displacement, the ribs must extend farther forward in proportion to the length of the cartridge, but as soon as the long cartridge has entered into the barrel to the same extent as the shorter cartridge it must come into that same axial line; hence the long ribs will stand in the way of the rise of the rear end of the cartridge.

The object of my invention is principally to adapt the guard-ribs of the said Elliot patent to the use of an arm constructed to use a long cartridge; and it consists in arranging the ribs so as to swing outward and inward in a horizontal plane, and constructing the breech-piece so as to impart such outward and inward movement to the said ribs, whereby after the cartridge has passed so far forward beneath the ribs as to have proportionately entered the barrel the ribs will be opened to permit the rear end of the cartridge to rise between them, and then the ribs be closed or returned, and as more fully hereinafter described.

The general construction of the arm in which my invention is illustrated is substantially the same as that in the Elliot patent before referred to, and only requires a brief description.

A represents the receiver, to the forward end of which the barrel B is attached, and beneath the barrel is the magazine C, opening into the receiver beneath the barrel; D, the breech-piece, which is moved backward and forward by means of a handle, E, surrounding the magazine, and from which a slide, P, extends into connection with a locking-brace, G, hung to the breech-piece D near its forward end, as at *a*, and so that when the breech-piece is in its closed position the said locking-brace G will bear against abutments H, prepared for it in the receiver. These abutments are arranged each at one side of the center of the receiver, and so as to leave a passage between them, but so that as the handle E is moved rearward the brace will be raised, as indicated in broken lines, Fig. 1, so as to escape the abutment, and then, continuing the movement of the handle, the breech-piece will be thrown to its open position, as seen in Fig. 2. I, the carrier, hung in the receiver in rear of the abutments H and below the breech-piece, as upon a pivot, *b*, is adapted to be raised as the breech-piece approaches its open position and turned downward as the breech-piece approaches its closed position, substantially the same as in the said Elliot patent, it moving freely in the passage between the abutments H H. When the carrier is in its down position, it receives a cartridge from the magazine, as seen in Fig. 1; but when the carrier is raised the forward end of the cartridge is brought directly in rear of the open end of the barrel, the cartridge itself standing in a position inclined downward and rearward from the barrel, and from which position it must be raised into a horizontal position in line of the barrel before it can fully pass into the barrel.

In each side of the receiver, and in substantially a horizontal plane, two ribs, J K, are arranged through openings in the receiver, and hung therein upon pivots *d*, so as to swing outward and inward in a horizontal plane, as from the position in Fig. 4 to that seen in Fig. 5, and return. These ribs lie above the carrier, as seen in Fig. 3, and the distance between them when in the closed position, as seen in Figs. 4 and 7, is less than the diameter of the head and the rear portion of the body of the cartridge, and so that the cartridge on the carrier lies beneath the ribs, and as the carrier rises the ribs will prevent the cartridge from being thrown from the carrier or displaced. The forward end of the ribs extends so far forward that were they immovable they would interfere with the rise of the cartridge into line with the barrel.

The breech-piece D carries upon its sides cams *e e*, *f f*, and *g g*, at different points, adapted to act upon corresponding shoulders, *i*, on the ribs forward of the pivots, or upon the rear extensions, *l*, of the ribs, as the case may be.

To illustrate the operation of this invention, I refer to Figs. 4, 5, 6, 7, and 8. In Fig. 4 the

breech-piece is shown in its extreme open position and with the cartridge as beneath the ribs J K. The ribs are held in their closed position by the part of the breech-piece which extends from the cams *e* to the cams *f*—this part then standing between the rear projections or tails of the ribs, and they will be thus held during the first part of the forward movement of the breech-piece. As the breech-piece advances—say to the position seen in Fig. 5—it forces the cartridge forward and enters it into the barrel, and after such entrance has been accomplished, the cams *e e* on the breech-piece, strike the corresponding shoulders, *i*, on the ribs J K, and turns the ribs outward, as seen in Figs. 5 and 8, opening them to a sufficient extent to permit the cartridge to rise between them. The ribs are permitted to open by the escape of the tails of the ribs in rear of the cams *f f*. The breech-piece now continues its forward movement, to complete the insertion of the cartridge into the barrel, and as it approaches its closed position the cams *g g* on the breech-piece strike the tail ends of the ribs and turn them inward to their closed position, as seen in Fig. 6, where they will be held by the cams until the breech-piece is next retracted. In the forward position the cams *f f* have passed forward of the forward end, *m*, of the ribs, so as to permit the ribs to escape therefrom. As the breech-piece is drawn rearward to extract the shell, or the cartridge if it be not exploded, the cams *f f* will strike the forward end of the ribs, and will open the ribs so that the cams may pass rearward between them, and until the cams *e* shall escape from the shoulders *i* on the ribs. Then the cams *f* come against the inner surface of the rib in rear of the pivots and return the ribs, as indicated in broken lines, Fig. 5, and this occurs before the forward end of the breech-piece shall have reached the shoulders *i i*, and so that the ribs will turn inward beneath the cartridge, as indicated in broken lines, Fig. 7, and so that the head of the cartridge or shell will ride upon the upper surface of the ribs in completing its rear movement on the upper surface of the ribs; and at a proper position with relation to the forward end of the breech-piece a shoulder, *n*, is formed, against which the rear end of the cartridge will strike before the breech-piece completes its rear position, and as in the Elliot patent before referred to, and so that the lower side of the head of the shell, meeting these shoulders as an obstruction to its further rear movement, will be held while the breech-piece retreats, carrying the upper edge of the cartridge with it, and thereby turning up the forward end and producing an ejection of the shell from the arm. By this construction the ribs may be made to extend so far forward over the long cartridge as to form a secure guard to prevent the accidental displacement of the cartridge under the movement of the carrier or otherwise. When the ribs are in their closed position, they are sub-

stantially flush with the outer surface of the receiver, and do not interfere with the convenient manipulation of the arm. It will be observed that they are in the open position only during a small part of the movement of the breech-piece, and are closed in both the open and closed position of the breech-piece.

In the use of a long cartridge, such as described, it is necessary that the head of the cartridge shall pass to a considerable extent in rear of the abutment against which the locking-brace rests, for if the arm be not so constructed as to permit this movement of the cartridge to the rear of the abutment the brace would require to be hung to a considerable distance in rear of the front end of the breech-piece, and the abutment accordingly, and such rear position of the abutment would necessarily increase the length of the receiver to the extent to which the brace and abutment were thus moved rearward.

The abutment is formed in two parts—one at each side of the center, as before described—so that the arm of the brace may work backward and forward between the two parts. These parts are seen in Fig. 3. In order to permit the cartridge to pass rearward between them, they are constructed with a recess, *r*, upon their inner sides, (see Fig. 3,) these recesses being to a sufficient extent to permit the cartridge to pass between them.

I have represented the ribs as positively turned inward by the cams on the breech-piece, and this I prefer, for the reason that it makes the movement positive and avoids the use of springs; but the movement in one direction may be made positive by the breech-piece, and in the opposite direction by springs—say, as seen in Fig. 9—the cams acting to impart a positive inward movement and the springs to cause the outward movement; and while I prefer to make the recesses in which the ribs work entirely through the receiver, they may be made upon the inside of the receiver without cutting through to the outside, as seen in Fig. 9. So far as the ribs and up and down swinging carrier are concerned, the mechanism by which the breech-piece is thrown backward and forward and the carrier raised is immaterial to this invention, and is applicable to various constructions of arms. This part of my invention is not to be understood as limited to the particular mechanism herein shown and described.

I claim—

1. In a magazine fire-arm, the combination of the magazine beneath the barrel and opening into the receiver at the rear, a longitudinal reciprocating breech-piece, a carrier hung at the rear and adapted to receive a cartridge from the magazine and present it in a position forward of the front face of the breech-piece, the ribs *J K*, hung longitudinally in the receiver above the carrier and so as to swing outward and inward in a horizontal plane, and the breech-piece provided with cams adapted to open and close the said ribs in the longitudinal movement of the breech-piece, substantially as described.

2. In a magazine fire-arm, the combination of the magazine beneath the barrel and opening into the receiver at the rear, a longitudinal reciprocating breech-piece, a carrier hung at the rear and adapted to receive a cartridge from the magazine and present it in a position forward of the front face of the breech-piece, the ribs *J K*, hung longitudinally in the receiver above the carrier and so as to swing outward and inward in a horizontal plane, the said ribs constructed with an extension in rear of their pivot and with shoulders *i* forward of their pivot, and the breech-piece provided with cams corresponding to the said shoulders and extensions of the ribs, substantially as described, and whereby in the opening and closing movements of the breech-piece the ribs will be correspondingly opened and closed by said cams, for the purpose specified.

3. The combination, in a magazine fire-arm, of the receiver, the barrel, the magazine located longitudinally beneath the barrel and opening into the receiver at the rear, a longitudinally-reciprocating breech-piece, a locking-brace, *G*, hung near the forward end of the breech-piece, the abutments *H* in the receiver, against which the said brace may stand when the breech-piece is in its closed position, a carrier hung in the receiver below the breech-piece and adapted to work up and down between said abutments *H H*, the said abutments being forward of the place of rest for the rear end of the cartridge on the carrier, and the said abutments each constructed with a recess, *r*, to permit the rear end of the cartridge to pass between them, substantially as described.

CARL J. EHBETS.

Witnesses:

EDWD. J. MURPHY,
FRANKLIN F. KNOUS.