

(19) World Intellectual Property Organization
International Bureau



(43) International Publication Date
13 October 2011 (13.10.2011)

(10) International Publication Number
WO 2011/127436 A3

- (51) **International Patent Classification:**
A61B 19/00 (2006.01) G08B 21/02 (2006.01)
A61B 1/04 (2006.01)
- (21) **International Application Number:**
PCT/US2011/031832
- (22) **International Filing Date:**
8 April 2011 (08.04.2011)
- (25) **Filing Language:** English
- (26) **Publication Language:** English
- (30) **Priority Data:**
61/322,049 8 April 2010 (08.04.2010) US
- (71) **Applicant (for all designated States except US):**
HEMOSONICS, LLC [US/US]; 310 4th Street NE,
Suite 104, Charlottesville, Virginia 22902 (US).
- (72) **Inventors; and**
- (71) **Applicants :** **VIOLA, Francesco** [—/US]; 745 Walker
Square, #3C, Charlottesville, Virginia 22903 (US).
WALKER, William F. [—/US]; 778 Belvedere Boule-
vard, Charlottesville, Virginia 22901 (US). **BROWNE,**
Gregory V. [—/CA]; 617 Pine Street, Victoria, British
Columbia V8V 2P6 (CA). **LOOKER, Adam** [—/CA];

1-146 Clarence Street, Victoria, British Columbia V8V 2J2 (CA). **ROY, Bryan** [—/CA]; 709 Aros Road, Cobble Hill, British Columbia V0R 1L4 (CA). **HANSEN, Bjarne** [—/CA]; 1000 DeCosta Place, Victoria, British Columbia V9A 6Y3 (CA).

(74) **Agents:** **CARLIN, Gregory J.** et al.; McKeon, Meunier, Carlin & Curfman, LLC, Suite 900, 817 W. Peachtree Street NW, Atlanta, Georgia 30308 (US).

(81) **Designated States** (unless otherwise indicated, for every kind of national protection available): AE, AG, AL, AM, AO, AT, AU, AZ, BA, BB, BG, BH, BR, BW, BY, BZ, CA, CH, CL, CN, CO, CR, CU, CZ, DE, DK, DM, DO, DZ, EC, EE, EG, ES, FI, GB, GD, GE, GH, GM, GT, HN, HR, HU, ID, IL, IN, IS, JP, KE, KG, KM, KN, KP, KR, KZ, LA, LC, LK, LR, LS, LT, LU, LY, MA, MD, ME, MG, MK, MN, MW, MX, MY, MZ, NA, NG, NI, NO, NZ, OM, PE, PG, PH, PL, PT, RO, RS, RU, SC, SD, SE, SG, SK, SL, SM, ST, SV, SY, TH, TJ, TM, TN, TR, TT, TZ, UA, UG, US, UZ, VC, VN, ZA, ZM, ZW.

(84) **Designated States** (unless otherwise indicated, for every kind of regional protection available): ARIPO (BW, GH, GM, KE, LR, LS, MW, MZ, NA, SD, SL, SZ, TZ, UG, ZM, ZW), Eurasian (AM, AZ, BY, KG, KZ, MD, RU, TJ,

[Continued on next page]

(54) **Title:** HEMOSTATIC PARAMETER DISPLAY

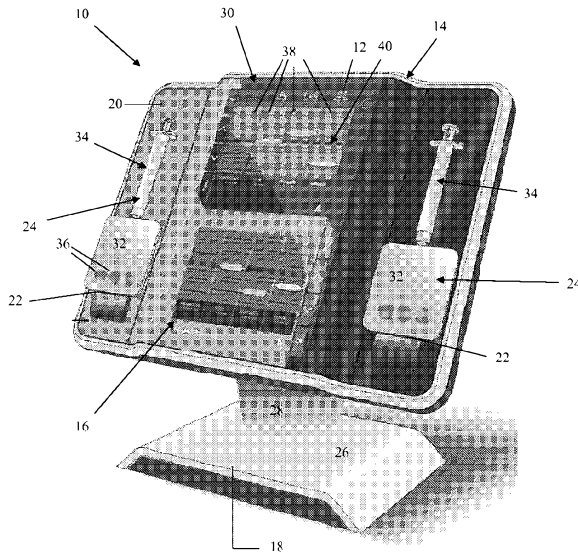

Fig. 1

(57) **Abstract:** A system for displaying a plurality of hemostatic indexes is disclosed. The system includes a communication receiver configured to receive the hemostatic indexes and a graphical user interface (GUI) connected to the communication receiver and configured to simultaneously display the hemostatic indexes. The hemostatic indexes are derived from a plurality of independent measurements, such as the mechanical measurements determined using the sonorheometry systems and processes.



WO 2011/127436 A3



TM), European (AL, AT, BE, BG, CH, CY, CZ, DE, DK, EE, ES, FI, FR, GB, GR, HR, HU, IE, IS, IT, LT, LU, LV, MC, MK, MT, NL, NO, PL, PT, RO, RS, SE, SI, SK, SM, TR), OAPI (BF, BJ, CF, CG, CI, CM, GA, GN, GQ, GW, ML, MR, NE, SN, TD, TG).

— *before the expiration of the time limit for amending the claims and to be republished in the event of receipt of amendments (Rule 48.2(h))*

(88) Date of publication of the international search report:

2 February 2012

Published:

— *with international search report (Art. 21(3))*

HEMOSTATIC PARAMETER DISPLAY

CROSS-REFERENCE TO RELATED APPLICATIONS

[0001]The present application claims priority to and hereby incorporates by reference in its entirety U.S. provisional patent application no. 61/322,049 entitled “Novel Technology for Point-of-Care Assessment of Hemostasis” and filed on April 8, 2010.

FIELD OF THE INVENTION

[0002]The present invention relates to displays for physiologic parameters and more particularly displays with graphical user interfaces (GUI) for intuitively presenting physiologic parameters for easy use and interpretation by healthcare personnel.

BACKGROUND

[0003]The formation of a blood clot and its successive dissolution, referred to as the hemostatic process, is required to arrest blood loss from an injured vessel. This process is the result of a delicate functional balance between plasma coagulation factors (including fibrinogen), platelets, and fibrinolytic proteins. Each of these elements plays an important role in activating/deactivating the others, and the appropriate stimuli are necessary to prevent excessive blood loss without causing inappropriate thrombosis, see Laposata M., et al., *The Clinical Hemostasis Handbook*, Year Book Medical Publisher 1989.

[0004]The hemostatic process is initiated by the activation and subsequent adhesion of platelets to the site of injury within the vessel wall. Activated platelets recruit other platelets and interact with fibrinogen in the blood plasma via the glycoprotein IIb/IIIa receptor to form a platelet-plug that serves as the initial response to stop blood loss. Hemostasis then proceeds with a cascade of proteolytic reactions of the plasma coagulation proteins that ultimately form a three-dimensional network of fibrin that strengthens the platelet-plug. The fibrin chains are cross-linked and stabilized by the plasma factor XIIIa (FXIIIa). Platelets also have a central role in regulating the process of fibrin polymerization. The final step of hemostasis (i.e., fibrinolysis) involves the activation of the plasma protein plasmin, which dissolves the blood clot when its useful life is over. This cell-based model of hemostasis closely reflects the in vivo physiological process, e.g., see Hoffman et al., “A cell-based model of hemostasis;” *Thromb. Haemost.* 2001; 85:958-965 and Becker, “Cell-Based Models

of Coagulation: A Paradigm in Evolution;” J. Thromb. Thrombolysis 2005; 20:65-68.

[0005]The mechanical properties of blood clots have implications for its function of stopping blood loss. Alterations in clot structure and its underlying mechanical properties have been implicated in thrombotic disease and other life threatening pathologies, see Weisel, J.W., “Enigmas of Blood Clot Elasticity;” Science 2008; 320:456. Recently, it was shown that fibrin clots of patients affected by premature coronary artery disease have a different structure and higher stiffness compared to the fibrin clots of healthy age-matched controls, see Collet et al, “Altered Fibrin Architecture is Associated with Hypofibrinolysis and Premature Coronary Atherothrombosis;” Arterioscler. Thromb. Vasc. Biol. 2006; 26:2567-2573.

[0006]The mechanics of fibrin networks have been studied extensively at the macroscopic level see Ryan et al., “Structural Origins of Fibrin Clot Rheology”; Biophys. J. 1999; 77:2813-2826 and Jen et al., “The Structural Properties and Contractile Force of a Clot;” Cell Motil. 1982; 2:445-455. The viscoelastic properties of individual fibrin strands have also been investigated by means of AFM (see Liu et al., “Fibrin Fibers Have Extraordinary Extensibility and Elasticity;” Science 2006; 313:634) and “optical tweezers,” see Collet et al., “The elasticity of an individual fibrin fiber in a clot;” Proc. Natl. Acad. Sci. USA 2005; 102:9133-9137.

[0007]Disruption of the hemostatic balance plays a role in the onset of potentially fatal conditions, including myocardial infarction, stroke, deep vein thrombosis, pulmonary embolism, and excessive bleeding, see Hoyert et al., “Deaths: preliminary data for 2003”, Natl. Vital Stat. Rep. 2005; 53:1-48 and Hambleton et al., “Coagulation: Consultative Hemostasis”; Hematology 2002; 1:335-352. These conditions account for over 30% of all deaths in the developed world. The ability to recognize and quantify defects of the hemostatic process may reduce mortality and implement appropriate treatment.

[0008]Further improvements in the detection and treatment of hemostatic defects are therefore desired.

SUMMARY

[0009]In one embodiment, the present invention includes a system for displaying one or more of a plurality of hemostatic indexes, the system having a communication receiver and a GUI. The communication receiver is configured to receive the hemostatic indexes. The GUI is connected to the communication receiver and configured to display one, or simultaneously at least two, of the hemostatic indexes.

The hemostatic indexes are derived from one or more of a plurality of independent measurements.

[0010] In one example, one of the indexes may be calculated from two of the independent measurements, such as from ultrasound measurements on two sample wells containing different reagents.

[0011] The hemostatic indexes may include a coagulation factor function, a fibrinogen concentration, a fibrinogen function, a platelet function and a fibrinolysis function. The coagulation factor may include at least one of an intrinsic activation factor or an extrinsic activation factor. The GUI may be further configured to display hematocrit, hemoglobin concentration and red cell count simultaneously with the two hemostatic indexes.

[0012] Also, the GUI may be configured to display the functional hemostasis indexes as a numerical score or a graphical depiction or with varying colors.

[0013] In another embodiment, the GUI is further configured to display a history of the hemostatic indexes and clinical interventions overlaid on the history. At least one portion of the history may include an array of graphical indicators, with each of the graphical indicators representing one of the hemostatic indexes at some time in the history. The graphical indicators may have a relative positioning configured to communicate a hemostatic condition of the subject at that time in history.

[0014] In yet another embodiment, the GUI may be further configured to display a treatment recommendation based on the at least two hemostatic indexes. For example, the treatment recommendation may be guiding transfusion of platelets, cryoprecipitate, plasma, red cells or antifibrinolytics. Or, the treatment recommendation is for guiding therapies of at least one of an anti-platelet drug, anti-coagulant drug or pro-fibrinolysis drug.

[0015] In another embodiment, a method includes deriving a plurality of hemostatic indexes from a plurality of independent measurements and displaying at least two of the hemostatic indexes.

[0016] In another embodiment, a system for measuring hemostatic characteristics of a blood sample includes a processor and a GUI. The processor is configured to receive a data stream of stiffness measurements of the blood sample and to estimate a possible range of a functional hemostatic index based on the data stream. The GUI is connected in communication with the processor and is configured to display the possible range of the functional hemostatic index.

[0017]Also, the processor may be configured to determine changes in the possible range as new data is received from the data stream and the GUI is configured to dynamically adapt a graphical element to express those changes.

[0018]Advantages of embodiments of the present invention include the ability to show two or more hemostatic indexes at the same time wherein the prior art is limited to serial tests. Another advantage is the ability for healthcare personnel to see the past history of various hemostatic indexes and the impact of various treatments. Additionally, healthcare personnel may benefit from display of trends in the hemostatic indexes and are able to more quickly apply preventive treatment in urgent care situations.

BRIEF DESCRIPTION OF THE SEVERAL VIEWS OF THE DRAWINGS

[0019]Fig. 1 is a perspective view of a functional hemostatic index determination and display system;

[0020]Figs. 2A and 2B are diagrams of sonorheometry to determine the hemostatic indexes displayed in Fig. 1;

[0021]Figs. 3A-3F show a plurality of GUI display configurations of the system of Fig. 1 indicating different patient conditions;

[0022]Fig. 4 shows a historical display of test results with multiple hemostatic indexes at various points in history;

[0023]Fig. 5 shows a historical display with a single functional hemostatic index as it changes during the history;

[0024]Fig. 6 is a perspective view of a functional hemostatic index determination and display system testing two subjects in parallel;

[0025]Fig. 7 is a perspective view of a functional hemostatic index determination and display system operating a surface activation test;

[0026]Fig. 8 is a GUI showing use of color to indicate normal and abnormal test results;

[0027]Fig. 9 is a method for determining and displaying a plurality of hemostatic indexes;

[0028]Figs. 10-18 show a graphical display of a graphical element (a bar) that dynamically shrinks as measurement confidence increases during determination of a functional hemostatic index; and

[0029] Fig. 19 is a schematic of a functional hemostatic index determination and display system as a network entity.

DETAILED DESCRIPTION

[0030] The inventors have made the following observations. Unregulated hemostasis, manifested either as thrombotic disease or excessive bleeding, represents one of the leading causes of morbidity and mortality in the developed world. For example, millions of patients in the United States are currently prescribed anti-platelet medications (such as aspirin or clopidogrel) or anti-coagulation drugs (such as coumadin, heparin or direct thrombin inhibitors) to prevent the occurrence of thrombotic conditions. However, it has been estimated that 5-60% of these patients may not respond adequately to aspirin and 4-30% to clopidogrel, for example, leading to higher risks of recurring thrombotic events or excessive bleeding.

[0031] Excessive bleeding often occurs during trauma, major surgical procedures, and on the battlefield. In these cases, transfusion of blood and its derived products are used in clinical practice to manage excessive bleeding. Generally, there are four treatment options available, each corresponding to a specific hemostatic defect: (a) fresh frozen plasma (FFP) to restore the plasma coagulation proteins, (b) platelet concentrate to restore platelets, (c) cryoprecipitate to restore fibrinogen, and (d) anti-fibrinolytics to slow the activity of the clot-dissolving proteins. Additionally, packed red blood cells (RBCs) are administered if hematocrit or hemoglobin falls within a certain threshold level.

[0032] While transfusions of blood products have had a great impact in saving lives, blood and its derived products are scarce and have to be carefully optimized. Furthermore, transfusion therapies carry the risks of possible allergic reactions, a variety of viral and bacterial infections, and worsened outcomes. The use of blood products is particularly intensive in cardiac surgery involving cardio-pulmonary bypass (CPB), where over 60% of patients experience excessive intra and post-operative bleeding.

[0033] It has been estimated that CPB surgeries account for roughly 20% of the total blood products used in the United States, with significant variations in protocols and guidelines among different institutions. Intra- and post-operative bleeding in CPB is often the result of blood being heavily anti-coagulated and exposed to the foreign surfaces of the extracorporeal circuitry. Loss of platelets, abnormal platelet function,

hemodilution, inadequate function of the fibrinolytic system, and patients' cooling/warming also contribute to failure of the hemostatic system, which has to be corrected with allogenic blood products.

[0034]Several protocols and guidelines have been developed in the past years to optimize transfusion therapies in order to minimize the likelihood of negative outcomes, save valuable resources, and generate financial savings to the healthcare systems. Chief among those is a recent report from The Society of Thoracic Surgeons Blood Conservation Guideline Task Force in combination with The Society of Cardiovascular Anesthesiologists Special Task Force on Blood Transfusions. One of the key components of these protocols regards the use of POC diagnostic tests of coagulation and platelet function to recognize abnormalities of the hemostatic process. In clinical practice, however, empirical approaches are often used, and transfusions are administered with little or no quantitative guidance. Table I below summarizes some of the available treatments.

Table I

	<i>Bleeding Patient</i>	<i>Clotting Patient</i>
Problem with Coagulation Factors	Transfuse Fresh Frozen Plasma	Administer Anti-coagulant (coumadin, heparin, direct thrombin inhibitor, etc)
Problem with Fibrinogen	Transfuse Cryoprecipitate	N/A
Problem with Platelets	Transfuse Platelets	Administer Anti-platelet therapy (aspirin, Plavix, etc)
Problem with Fibrinolysis	Administer Anti-fibrinolytic (aminocaproic acid or tranexamic acid, etc)	Administer Pro-fibrinolysis (tissue plasminogen activator, etc)

[0035]Current tests of hemostasis can be divided into three broad categories: endpoint biochemical assays, mechanical/viscoelastic analyzers, and platelet-specific tests. Endpoint assays are traditionally performed on blood plasma and include such tests as the pro-thrombin time (PT/INR), activated partial thromboplastin time (aPTT), and the activated clotting time (ACT). A variety of methodologies, ranging from optical detection to flow impediment, are employed to determine the time required to reach a

pre-defined endpoint that represents the clotting time. The output of these tests is generally the clotting time expressed in seconds (or minutes) or a single number selected from an arbitrary scale such as in the case of the INR (International Normalized Ratio).

[0036] While each of these assays measures a different aspect of the coagulation factors, even in combination they do not provide a complete representation of overall hemostasis. See, Gravlee et al., "Predictive value of blood clotting tests in cardiac surgical patients"; *Ann. Thorac. Surg.* 1994; 58:216-221 and Bajaj et al., "New insights into how blood clots: Implication for the use of APTT and PT as coagulation screening tests and in monitoring anticoagulant therapy"; *Semin. Thromb. Hemost.* 1999; 25:407-418.

[0037] Fibrinogen level, for example, is typically measured using the standard Clauss method, another end-point assay. The clotting time of platelet free plasma is measured in the presence of thrombin and compared to a calibration curve to determine fibrinogen level. The output of this test is the concentration of fibrinogen, typically expressed in units of mg/dl. The end point tests are further limited by the absence of active platelets.

[0038] In contrast, mechanical methods, such as the TEG[®] (Haemoscope), ROTEM[®] (Pentapharm), HAS (Hemodyne) and SonoClot[®] (Sienco), measure the contribution of all the components of hemostasis in whole blood. These methods have been widely studied and shown to offer valuable clinical and scientific insights, see Ganter et al., "Coagulation Monitoring: Current Techniques and Clinical Use of Viscoelastic Point-of-Care Coagulation Devices"; *Anesth. Analg.* 2008; 106:1366-1374.

[0039] Existing mechanical methods, however, utilize complex and expensive mechanical transducers, resulting in instruments that are difficult to operate and to interpret. The output of these systems is generally a curve that describes the overall hemostatic process along with some numerical scores. Further, the large mechanical strains (in the range of 8% to 16%) applied to the blood samples have been shown to interfere with clot formation and limit sensitivity and speed of the measurements, see Evans et al., "Rheometry and associated techniques for blood coagulation studies"; *Med. Eng. Phys.* 2008; 30:671-679 and Burghardt et al., "Nonlinear viscoelasticity and thromboelastograph: Studies on bovine plasma clots"; *Biorheology* 1995; 32:621-630.

[0040] The most common platelet tests are the platelet count and platelet aggregation. In a healthy patient, platelet count is between 150K and 400K platelets per mm³. Platelet aggregation measures the ability of platelets to stick together and form small clumps. These tests are typically performed in central laboratories using platelet rich plasma (PRP), even though whole blood assays have recently emerged. Limitations include the necessity to perform the measurements with anticoagulated blood, which does not represent actual physiology, and the long turn-around-times (>45 minutes) to obtain results from the central lab.

[0041] Embodiments of the present invention disclosed herein include systems and methods for intuitively displaying a plurality of functional hemostasis indexes that are directly related to the therapies available for both the hypo-coagulable (i.e., bleeding) and hyper-coagulable (i.e., clotting) patient. The term "hemostasis indexes" as used herein indicates a series of measures that are related to physiological components or parameters involved directly or indirectly in the physiological process of hemostasis (as opposed to raw mechanical parameters). Knowledge of the function of these physiological components of hemostasis can enable diagnostic decisions by healthcare professionals. For example, these functional hemostasis indexes may include: (1) coagulation factor function, (2) fibrinogen concentration and/or function, (3) platelet function and (4) fibrinolytic function. As discussed above, the inventors have also recognized that transfusion of packed red cells is common in a bleeding patient. Therefore, an additional hemostasis index represented by the hematocrit, hemoglobin concentration or red cell count so that the system can provide information about additional possible transfusion products.

[0042] In one embodiment, the hemostatic indexes are determined using sonorheometry. Coagulation factor function (when determined by sonorheometry) is the time at which significant fibrin formation occurs which is measured as the time at which clot stiffening starts. It is determined by finding the point on the time-stiffness curve where stiffness rises by an order of magnitude above baseline. Normal values are about 3.5 minutes with +/- 10% or .35 minutes. Pathological values can fall as low as 1 minute.

[0043] Fibrinogen function (when determined by sonorheometry) is the maximum clot stiffness in the absence of platelet function. Either stiffness units or traditional mg/dL units may be used. It is determined as the maximum stiffness in a test well having kaolin plus ReoPro[®]. Normal values are 10⁴ in stiffness which corresponds to about

300 mg/dL. Normal variation is about +/- 5%. Pathological values range from 15 mg/dL to above 450 mg/dL.

[0044]Platelet function (when determined by sonorheometry) is the multiplicative increase in clot stiffness that is attributed to platelets. It is determined by dividing the maximum stiffness in a test well with kaolin by the test well with kaolin plus ReoPro. It yields a dimensionless number that normally is 10 +/- 1 with pathological values ranging as low as 1.

[0045]Fibrinolytic function (when determined by sonorheometry) is the time at which fibrinolysis begins, and in some cases may include the effect of an accelerant. Without an accelerant, it is determined to be the point on the time-stiffness curve where stiffness falls by 50%. Normal is generally defined as 90 minutes with pathological values ranging as low as 10 minutes. An expected range is about 60 to 120 minutes based on prior experience.

[0046]With reference now to Fig. 1, embodiments of the present invention include a system 10 for displaying a plurality of hemostatic indexes 12. The system includes a communication receiver 14 configured to receive the hemostatic indexes 12 and a graphical user interface (GUI) 16 connected to the communication receiver 14 and configured to display one, or simultaneously at least two, of the hemostatic indexes 12. The hemostatic indexes 12 are derived from a plurality of independent measurements, such as the mechanical measurements determined using the sonorheometry systems and processes described in more detail below.

[0047]The term "GUI" or "graphical user interface" as used herein includes any hardware, software, firmware or combination thereof, or even non-electronic interfaces, capable of generating graphical depictions such as liquid-crystal displays, computer monitors, cell phone or PDA screens, televisions, tablet computers etc.

[0048]The term "independent measurement" as used herein refers to separate tests, sonorheometry or otherwise, which may be performed on a single sample, such as a series ultrasound tests using the same instrument, or on multiple samples, such as parallel tests by multiple instruments or sensors.

[0049]The terminology used herein is for the purpose of describing particular embodiments only and is not intended to be limiting of the invention. As used herein, the singular forms "a", "an" and "the" are intended to include the plural forms as well, unless the context clearly indicates otherwise. It will be further understood that the terms "comprises" and/or "comprising," when used in this specification, specify the

presence of stated features, integers, steps, operations, elements, and/or components, but do not preclude the presence or addition of one or more other features, integers, steps, operations, elements, components, and/or groups thereof.

[0050]The corresponding structures, materials, acts, and equivalents of all means or step plus function elements in the claims below are intended to include any structure, material, or act for performing the function in combination with other claimed elements as specifically claimed. The description of the present invention has been presented for purposes of illustration and description, but is not intended to be exhaustive or limited to the invention in the form disclosed. Many modifications and variations will be apparent to those of ordinary skill in the art without departing from the scope and spirit of the invention. The embodiment was chosen and described in order to best explain the principles of the invention and the practical application, and to enable others of ordinary skill in the art to understand the invention for various embodiments with various modifications as are suited to the particular use contemplated.

[0051]Any combination of one or more computer readable medium(s) may be utilized. The computer readable medium may be a computer readable signal medium or a computer readable storage medium. A computer readable storage medium may be, for example, but not limited to, an electronic, magnetic, optical, electromagnetic, infrared, or semiconductor system, apparatus, or device, or any suitable combination of the foregoing. More specific examples (a non-exhaustive list) of the computer readable storage medium would include the following: an electrical connection having one or more wires, a portable computer diskette, a hard disk, a random access memory (RAM), a read-only memory (ROM), an erasable programmable read-only memory (EPROM or Flash memory), an optical fiber, a portable compact disc read-only memory (CD-ROM), an optical storage device, a magnetic storage device, or any suitable combination of the foregoing. In the context of this document, a computer readable storage medium may be any tangible medium that can contain, or store a program for use by or in connection with an instruction execution system, apparatus, or device.

[0052]A computer readable signal medium may include a propagated data signal with computer readable program code embodied therein, for example, in baseband or as part of a carrier wave. Such a propagated signal may take any of a variety of forms, including, but not limited to, electro-magnetic, optical, or any suitable combination

thereof. A computer readable signal medium may be any computer readable medium that is not a computer readable storage medium and that can communicate, propagate, or transport a program for use by or in connection with an instruction execution system, apparatus, or device.

[0053] Program code embodied on a computer readable medium may be transmitted using any appropriate medium, including but not limited to wireless, wireline, optical fiber cable, RF, etc., or any suitable combination of the foregoing.

[0054] Computer program code for carrying out operations for aspects of the present invention may be written in any combination of one or more programming languages, including an object oriented programming language such as Java, Smalltalk, C++ or the like and conventional procedural programming languages, such as the "C" programming language or similar programming languages. The program code may execute entirely on the user's computer, partly on the user's computer, as a stand-alone software package, partly on the user's computer and partly on a remote computer or entirely on the remote computer or server. In the latter scenario, the remote computer may be connected to the user's computer through any type of network, including a local area network (LAN) or a wide area network (WAN), or the connection may be made to an external computer (for example, through the Internet using an Internet Service Provider).

[0055] Aspects of the present invention are described below with reference to flowchart illustrations and/or block diagrams of methods, apparatus (systems) and computer program products according to embodiments of the invention. It will be understood that each block of the flowchart illustrations and/or block diagrams, and combinations of blocks in the flowchart illustrations and/or block diagrams, can be implemented by computer program instructions. These computer program instructions may be provided to a processor of a general purpose computer, special purpose computer, or other programmable data processing apparatus to produce a machine, such that the instructions, which execute via the processor of the computer or other programmable data processing apparatus, create means for implementing the functions/acts specified in the flowchart and/or block diagram block or blocks.

[0056] These computer program instructions may also be stored in a computer readable medium that can direct a computer, other programmable data processing apparatus, or other devices to function in a particular manner, such that the instructions stored in the computer readable medium produce an article of

manufacture including instructions which implement the function/act specified in the flowchart and/or block diagram block or blocks.

[0057] The computer program instructions may also be loaded onto a computer, other programmable data processing apparatus, or other devices to cause a series of operational steps to be performed on the computer, other programmable apparatus or other devices to produce a computer implemented process such that the instructions which execute on the computer or other programmable apparatus provide processes for implementing the functions/acts specified in the flowchart and/or block diagram block or blocks.

[0058] Some embodiments of the present invention use an ultrasound-based technology (“sonorheometry”) to quantify the dynamic changes in mechanical properties of whole blood during the process of coagulation and clot dissolution. This provides information about the role of the coagulation factors, fibrinogen, platelets, and fibrinolytic proteins to overall hemostatic function.

[0059] Sonorheometry uses the phenomenon of acoustic radiation force to make repeated viscoelastic measurements of a whole blood sample. Acoustic radiation force can be described as the transfer of momentum between an acoustic wave (or pulse) and a reflection or absorbing target. As a result of the transferred momentum, the target experiences a small unidirectional force in the direction of the wave (or pulse) propagation. For a perfect absorber, this can be mathematically defined as follows:

$$|\bar{F}| = \frac{2\alpha \langle I(t) \rangle}{c} = \frac{2\alpha PII}{c} PRF \quad (1)$$

[0060] where $|\bar{F}|$ is acoustic radiation force (in units of m^{-1}), α is the attenuation coefficient of the medium, c (in units of m/s) is the speed of sound in the medium, $I(t)$ (in units of W/m^2) is the instantaneous intensity of the beam (e.g., ultrasound beam), PII is pulse intensity integral, and PRF is pulse repetition frequency (typically measured in hertz), which characterizes the time interval between pulse or wave firings.

[0061] In order to exploit the acoustic radiation force phenomenon as a means to discern material properties of tissue, sonorheometry can be performed as a series of pulses transmitted so that the temporal characteristic of the acoustic radiation force approximates a step-function. In this step-wise radiation force that is applied, the resultant displacement profiles mimic responses observed in viscoelastic creep tests

and can be described by viscoelastic models such as the Voigt or Kelvin models. Parameters such as steady-state displacement or time constants can be extracted which characterize material properties of the tissue that the acoustic force radiation is applied to. When the target tissue is whole blood, sonorheometry as described herein can be used to monitor coagulation and clot dissolution properties (i.e., the hemostatic process).

[0062] Sonorheometry is performed using acoustic radiation force as a means to generate small and localized displacements within a sample, e.g., a whole blood sample. Returned echoes are processed to measure the induced displacements and determine viscoelastic properties of the sample. In at least one embodiment, displacements are quantified using a principal component-based estimator technique, such as is described in Mauldin, Jr. et al., "Reduction of echo decorrelation via complex principal component filtering," *Ultrasound Med. Biol.*, vol. 35, no. 8, pp. 1325-1343, 2009 and in U.S. Application Serial No.12.467,216 filed May 15, 2009 and titled "Reduction of Echo Decorrelation in Ultrasonic Motion Estimation."

[0063] In performing sonorheometry according to the present invention, for each measurement a series of N ultrasound pulses (where N =a positive integer) are fired toward a specified location within a blood sample at time intervals ΔT , e.g., see Figure 2A. Each pulse generates radiation force as energy is absorbed and reflected during propagation. This radiation force induces displacements within the blood sample that depend upon local force application and mechanical properties of the blood. Each pulse also returns an echo as a portion of its energy is reflected from cell/plasma interfaces within the blood. Because the tissue (blood) moves slightly from one transmission to the next, the path length between the ultrasound transducer and any given region within the target (blood) changes with pulse number. This change in path length can be readily estimated from differences in the arrival times of echoes from the same region, thereby accomplishing motion tracking of the sample. The series of N acoustic pulses are sent into the blood sample at a specified pulse repetition frequency (PRF). These pulses generate acoustic radiation force that induces a deformation field within the sample. The deformation field can be estimated from the time delays of the N returning echoes.

[0064] The ensemble of the time delays forms a time-displacement curve that describes the viscoelastic properties of the sample being analyzed. This process is then repeated M times (where M is a positive integer), with intervening relaxation

periods, to provide data about the dynamics of clot formation and dissolution. As blood coagulates reduction in displacement is observed. The values of the M steady-state displacements are combined to form a relative stiffness curve that is representative of the hemostatic process, e.g., see Figure 2B. The stiffness parameter is referred to as “relative” since the absolute magnitude of the radiation force is unknown due to its dependency on blood acoustic properties which change throughout coagulation. Alternatively the changes in acoustic properties (i.e., changes in acoustic attenuation α and speed of sound c) can be measured using a known reflector so that acoustic radiation force can be calculated and absolute stiffness values can be calculated.

[0065] In Figure 2B, the relative stiffness curve shows characteristic features labeled Time to Clot (TC1), Time to Final Clot (TC2), Angle (Θ), Final Stiffness (S), Beginning of Fibrinolysis (TL1) and End of Fibrinolysis (TL2). The hemostasis parameters indicated in Figure 2B are calculated by first fitting the sonorheometry relative stiffness data to a modified sigmoidal function such as, for example, the following model (although other models may be alternatively used to accomplish these calculations, such as a combination of linear trends or a combination of skewed error functions):

$$f(t) = \alpha \frac{t^{\beta}}{1 + e^{-\frac{(t-\gamma)}{\delta}}} + \epsilon \quad (2)$$

[0066] where t is experimental time (in seconds) and α , β , γ , δ and ϵ are parameters determined to best fit the model curve to the data.

[0067] The parameter TC1 corresponds to the rapid increase in relative stiffness, indicating the beginning of fibrin polymerization. Similarly, the parameter TC2 represents the ending of fibrin polymerization. TC1 and TC2 are calculated based on a threshold value of the derivative curve of the relative stiffness (20% of the minimum value). The angle Θ is the slope of the relative stiffness during fibrin polymerization, which extends generally between TC1 and TC2. The angle, defined as the slope of the line between TC1 and TC2, is indicative of the rate of fibrin polymerization. The final stiffness S (maximum stiffness) corresponding to the maximum stiffness of the clot. The maximum stiffness S depends upon platelet function and the stiffness of the fibrin network. The times TL1 and TL2 can be defined to represent the initial and final

phases of the fibrinolytic process and the consequent dissolution of the fibrin network (time to lysis). TL1, indicating the “lysis initiation time”, and TL2, indicating the “end of lysis time”, can be calculated by defining a new sigmoidal curve similar to that defined by equation (2), calculating the curve derivative, and estimating the times corresponding, for example, to twenty percent of the minimum of the derivative. A summary of the parameters generated is presented in Table II below:

Table II

TC ₁ , TC ₂	Measure initial and final fibrin formation	Function of fibrinogen and other coagulation factors
S	Fibrin and platelet activity	Function of fibrin network and platelet aggregation
⊖	Rate of fibrin polymerization	Function of fibrinogen and other coagulation factors
TL ₁ , TL ₂	Clot dissolving process	Function of fibrinolytic proteins of the plasma

[0068] In order to isolate the four main components of hemostasis, four sonorheometry measurements can be performed in parallel using a combination of agonists and antagonists reagents. In a possible embodiment, test well 1 may have kaolin powder to activate coagulation through the intrinsic pathway. Test well 2 may have a combination of kaolin and abciximab (ReoPro) to inhibit platelet aggregation. Test well 3 may have abciximab and thrombin to activate coagulation through the common pathway. Test well 4 may have tissue factor to activate coagulation through the extrinsic pathway. In one embodiment, the measurements in each well can be combined to form hemostatic indexes as shown in the Table III below:

Table III

Coagulation factors function (Intrinsic Pathway)	Time to clot TC ₁ in well #1
Coagulation factors function (Extrinsic Pathway)	Time to clot TC ₁ in well #4
Platelets function	Stiffness S differential between well #1 and well #2
Fibrinogen function	Stiffness S in well #3
Fibrinolysis function	Time to lysis TL ₁ in well #4

[0069] The measurements of hematocrit (HCT), hemoglobin concentration (HGB) and red cell count (RBC) can be performed using ultrasound signals by methods such as those disclosed in U.S. Prov. Pat. App. No. 61/443,084 filed on February 15th, 2011

and entitled "CHARACTERIZATION OF BLOOD PARAMETERS INCLUDING HEMATOCRIT AND HEMOSTASIS," and hereby incorporated in its entirety by reference.

[0070] In other embodiments, the hemostatic indexes may be obtained for display from one or more diagnostic devices that provide information regarding the process of coagulation and fibrinolysis (i.e., the hemostatic process). Such devices include, for example, methods based on direct measurements of blood viscoelasticity such as the TEG® (Haemoscope), ROTEM® (Pentapharm), HAS (Hemodyne) and SonoClot® (Sienco).

[0071] Referring again to Fig. 1, the system 10 of the present invention includes a base 18, a housing 20 containing various electronic components and software such as the communication receiver 14, a pair of consumable receptacles 22 holding consumables 24, and the GUI 16.

[0072] The base 18 is constructed of a molded plastic and includes a foot 26 or flange for resting upon a flat surface, such as a patient's bedside, and a post 28 extending upwards therefrom to support the housing 20. Advantageously, the space between the bottom edge of the housing 20 and the top of the foot 26 provides room for resting a storage container of the consumables 24. The base 18 may also function as a passage for wiring, power, communication or otherwise, connecting to the electronics within the housing 20 or the GUI 16.

[0073] The housing 20 includes a plurality of walls in a rectangular arrangement that is supported by the post 28 of the base 18 in an inclined, near vertical orientation for easy viewing by and interaction with healthcare personnel. Contained within the housing 20 may be various combinations of hardware, software, firmware and other electronics to support the application of sonorheometry to the consumables 24, operation of the GUI 16 (such as through a video card or driver) and other functions.

[0074] For example, selected components of Fig. 19 (described in more detail below) may be included within the housing 20 to enable the functions and processes described herein. Alternatively, the housing 20 may only contain very basic components for displaying the results of sonorheometry. For example, the communication receiver 14 may be a video card or video driver, a wireless receiver or basic hardware and software for communicating with cloud-based or other distributed processing power to receive the hemostatic indexes 12 and other information.

[0075] The housing 20 includes a front screen 30 comprised of a transparent plastic

that includes a central raised portion and a pair of lateral portions. The portions define planar surfaces. The lateral portions are on either side of the central raised portion and are recessed or spaced behind the central raised portion. The recessed position of the lateral portions provides clearance for the consumables 24 and defines the consumable receptacles 22, as shown in Fig. 1. The pair of consumable receptacles 22 are defined by the lateral portions of the front screen 30 and generally are slots or openings sized to receive the consumables 24 to provide testing access (such as by sonorheometry) to one or more blood samples.

[0076]The central portion houses a display or other screen or device upon which the GUI is presented.

[0077]For example, the consumables 24 may include a cartridge or card 32 connected to a syringe 34. The card 32 includes an array of multiple chambers or wells 36 in a side-by-side or serial relationship that are accessible by the syringe 34 via an inlet and channels defined in the card 32 that distribute portions of the blood into the wells. Within each of the wells 36 is a blood sample dispensed by the syringe 34 and usually one or more reagents, such as is described in U.S. Prov. Pat. App. No. 61/443,088 filed on February 15, 2011 and entitled, "Devices, Systems and Methods for Evaluation of Hemostasis," hereby incorporated in its entirety herein by reference. Different numbers of wells are possible, such as 2, 3 or 4 wells.

[0078]The term "blood sample" as used herein should be construed broadly to include such things as plasma or whole blood or some component of whole blood. For example, a blood sample may include blood, platelet poor plasma (PPP) or platelet rich plasma (PRP). If PPP or PRP are used for sonorheometry, however, ultrasound scattering material may be used in order to provide adequate ultrasound scattering to perform the measurements. For example, polystyrene beads can be used as they have neutral buoyancy in plasma.

[0079]Generally, when used herein the term "array" refers to spaced objects extending in a particular direction. The array configuration, however, could be any cluster or arrangement of the wells 36, not necessarily a linear one, wherein spacing along one axis is generally regular. Thus, the other axes could be somewhat offset from each other wherein the objects in the array extend in a common direction on one axis but are staggered above and below that axis. In the embodiment of Fig. 1, the wells 36 are in a serial array where they are not only regularly spaced, but in a straight line.

[0080]Disposed on one side of each of the wells 36 is a lens for coupling with and focusing sound or sonic energy emitted by corresponding sensors with operation supported by the electronics of the housing 20. This sonic energy is used to detect the mechanical parameters of the blood samples in the wells 36 which in turn are used to determine the hemostatic indexes using the principals described hereinabove.

[0081]In some embodiments of the present invention the GUI 16, includes a plurality of display portions 38 that are adjacent to and in a similar orientation to the sample wells 36. For example, the hemostatic indexes 12 may be depicted by an array of a similar number and orientation of graphical elements.

[0082]Each of the display portions 38 is configured to readily depict for easy interpretation, such as through numbers, colors or images, one of the hemostatic indexes 12. For example, the display portions 38 may include horizontal colored bars and percentage numbers that show parameters that include a coagulation factor function, a fibrinogen function (or concentration), a platelet function and/or a fibrinolysis function.

[0083]The colors of the colored bars may be used as a theme throughout the display and accompanying instructions and/or written documentation to associate information on a single one of the hemostatic indexes 12. For example, all items and documentation regarding the coagulation factor could be shown in red, the fibrinogen function in yellow, platelet function in purple and fibrinolytic function in light blue. In this manner, a healthcare person has a way to quickly associate various display items and documentation with the single function under stressful and fast-moving conditions.

[0084]The GUI 16 may also include a normal line 40 that when reached by the display portion visual indicator evidences a normal condition of the sample being tested.

[0085]Advantageously, the GUI is configured, through its display of the relative positioning of multiple (such as four) hemostatic indexes 12, to characterize hemostatic function and guide medical treatment. Fig. 3A, for example, shows a GUI from a hypothetical normal patient with no hemostatic defect. All of the hemostatic indexes 12 are at the same 100% (middle) level.

[0086]Fig. 3B shows a GUI from a hypothetical patient with reduced function of the coagulation factors (below 100%). This could be the consequence of anti-coagulation drugs, for example. Otherwise, in the case of a bleeding patient, fresh-frozen plasma

can be administered to restore function of the coagulation factors.

[0087]Fig. 3C shows a GUI of a hypothetical patient with reduced platelet function, such as in the case of the patient receiving clopidogrel (Plavix®) or aspirin therapy. Otherwise, in the case of a bleeding patient, this readout indicates that platelet concentrates should be administered to restore platelet number and function to the patient.

[0088]Fig. 3D shows a GUI of a hypothetical patient with increased fibrinolytic function. In this case, a bleeding patient should be administered an anti-fibrinolytic drug such as aminocaproic acid or tranexamic acid.

[0089]Fig. 3E shows a GUI of a hypothetical patient with reduced function of both coagulation factors and platelets. The reduction in platelet function is more severe than that showed previously in Fig. 3C. In the case of a bleeding patient, the GUI of Fig. 3E indicates the need to transfuse fresh frozen plasma along with platelet concentrates.

[0090]Fig. 3F shows a GUI of a hypothetical patient with an increased function of the coagulation factors. The GUI is thus indicating a need for administration of anti-coagulant drugs such as coumadin, heparin, or direct thrombin inhibitors, for example, to restore normal function.

[0091]In another potential embodiment, the display of coagulation factors is divided into intrinsic and extrinsic coagulation factors to indicate defects that are specific to each activation pathway. The function of the intrinsic and extrinsic coagulation factors would be displayed along with the function of platelets, fibrinogen and fibrinolysis.

[0092]Figs. 6 and 7 show other embodiments in which numerical scores are presented to quantify the function of the hemostatic components. Numerical scores can be presented as an arbitrary percentage or on an arbitrary numerical scale. In Figs. 6 and 7, for example, the GUI displays 100% for normal physiological function. Also shown (except for fibrinogen) is display of an arbitrary scale going from 0 to 10 with 5.0 representing normal physiological function. Also, a light gray bar across the display represents the line 40 of normal physiological hemostasis.

[0093]Units of measure could also be used to quantify the absolute concentration or number of some of the output parameters. In Figs. 6 and 7, functional fibrinogen concentration is quantified in units of mg/dl, for example.

[0094]The GUI 16 may also be configured to display the type of test administered to

the blood samples. In Fig. 7, a Surface Activation Test is performed with the use of kaolin or celite, for example, to activate coagulation through the intrinsic (i.e., contact) activation pathway. Different types of tests and activations can be performed by selecting the appropriate reagent set which is detected by the system 10 from the pre-loaded consumables 24, such as through an RFID tag, and then communicated through the GUI 16.

[0095]Fig. 6 shows an embodiment simultaneously using two consumable receptacles 22 for parallel testing of blood samples. As in prior embodiments, the solid normal line 40 across the GUI 16 indicates normal physiological conditions.

[0096]The GUI 16 may also be configured to dynamically change colors depending upon the status of the various hemostatic indexes 12. As shown in Fig. 8 for example, the graphical elements and numbers are color-coded with green representing normal, red representing increased function, and yellow representing reduced function.

[0097]In yet another embodiment, the GUI 16 may be configured to display additional hemostatic parameters such as: hematocrit (HCT), hemoglobin concentration (HGB) and/or red cell count (RBC). Display of the HCT, HGB or RBC values may inform the healthcare personnel to transfuse packed red blood cell units into a bleeding patient. Therefore, combining HCT, HGB, or RBC with the hemostatic indexes 12 can provide information about every possible transfusion product.

[0098]In other embodiments, the GUI 16 may be configured to display temporal progression of the hemostatic parameters. Such a display illustrates the progression of each hemostatic parameter as a function of procedure time, administered treatment (transfusions) and other landmark events.

[0099]Fig. 4, for example, shows three tests performed at three times (9:32 AM; 10:17 AM and 10:51 AM) during an hypothetical procedure in which both consumable receptacles (A and B) are used. Time relative to the beginning of the procedure is shown in the bottom scale, whereas absolute time is on the top scale. For each test performed there is an array of four color-coded symbols representing the four hemostatic indexes 12.

[00100]Fig. 5 shows an embodiment wherein a single hemostatic parameter can be selected for temporal display by the GUI 16. In this case fibrinogen in mg/dL is shown as a function of procedure time.

[00101]In another embodiment, as shown in Fig. 9, the present invention includes a

method for deriving and displaying hemostatic indexes. Mechanical properties of blood samples are measured 100 to generate independent measurements. The hemostatic indexes are derived 110 from the independent measurements. For example, one or more of a coagulation factor function, a fibrinogen concentration, a fibrinogen function, a platelet function and a fibrinolysis function may be derived in step 110. Also derived 110 from the independent measurements may be a hematocrit, hemoglobin concentration and/or red cell count.

[00102]Deriving 110 may also include deriving each of the hemostatic indexes from a plurality of the independent measurements. Also, deriving 110 may include deriving each of the hemostatic indexes from a corresponding one of the independent measurements.

[00103]The method may also include displaying 120 the hemostatic indexes, such as by using the GUI 16. For example, displaying 120 may include displaying a numerical score and/or a graphical element for the hemostatic indexes. Also, displaying 120 may include displaying a changing color to indicate dynamic changes in the hemostatic indexes or a same color to associate the hemostatic indexes with other information.

[00104]The method may also include estimating or calculating 125 and displaying 130 hematocrit, hemoglobin concentration and/or red cell count simultaneously with the at least two hemostatic indexes.

[00105]The method may also include displaying 140 a history of the hemostatic indexes and overlaying 150 one or more clinical interventions on the history. For example, displaying 140 the history may include displaying an array of graphical indicators each representing one of the hemostatic indexes at some time in the history. The graphical indicators may be positioned relative to each other to communicate a hemostatic condition of a subject at that point in time.

[00106]The method may also include displaying 160 a treatment recommendation based on the at least two hemostatic indexes. For example, the GUI 16 could display information guiding transfusion of at least one of platelets, cryoprecipitate, plasma, red cells or antifibrinolytics, or guiding therapies using an anti-platelet drug, anti-coagulant drug or pro-fibrinolysis drug.

[00107]In another embodiment, the system 10 is configured to determine a range of possible values given the current results of the measurements of the blood sample. In this manner, the healthcare personnel may receive early indication of trend without

having to wait the fully elapsed time. For example, as shown by the progression from Figs. 10-18, determination of coagulation factor function becomes progressively more confident as indicated by the vertical bar displayed by the GUI 16 on the right and the associated numerical information.

[00108] Each of the figures is a 60 second interval, starting with time zero in Fig. 10 wherein a zero to infinite range of the possible 100% normalized index is shown. As each time interval passes, the range and accompanying height of the bar shrinks to express increasing certainty around the projected result. At 1 minute the range is 0-300; at 2 minutes 0-200; at 3 minutes 0-100 (since normal is 3.5 minutes +/- 10% CF will definitely not be high with no change in the stiffness); at 4 minutes 0-75 (now the patient must be in low territory because they're outside the normal range at the 3.85 minute high end); at 5 minutes the range drops to 0-60; at 6 minutes 0-50; at 7 minutes 0-43 and with the final result at 8 minutes of 38.

[00109] Notably, the GUI 16 is configured to continuously shrink the height of the bar (or other visual characteristic) to show increasing confidence with the final minimum thickness and a white line indicating the final result.

[00110] Referring now to Fig. 19, a schematic diagram of a central server 500, or similar network entity, configured to implement a VPD system, according to one embodiment of the invention, is provided. As used herein, the designation "central" merely serves to describe the common functionality the server provides for multiple clients or other computing devices and does not require or infer any centralized positioning of the server relative to other computing devices.

[00111] As may be understood from Fig. 19, in this embodiment, the central server 500 may include a processor 510 that communicates with other elements within the central server 500 via a system interface or bus 545. Also included in the central server 500 may be a display device/input device 520 for receiving and displaying data, such as via the GUI 16 described above. This display device/input device 520 may be, for example, a keyboard or pointing device that is used in combination with a monitor. The central server 500 may further include memory 505, which may include both read only memory (ROM) 535 and random access memory (RAM) 530. The server's ROM 535 may be used to store a basic input/output system 540 (BIOS), containing the basic routines that help to transfer information across the one or more networks.

[00112] In addition, the central server 500 may include at least one storage device 515, such as a hard disk drive, a floppy disk drive, a CD Rom drive, or optical disk drive, for storing information on various computer-readable media, such as a hard disk, a removable magnetic disk, or a CD-ROM disk. As will be appreciated by one of ordinary skill in the art, each of these storage devices 515 may be connected to the system bus 545 by an appropriate interface. The storage devices 515 and their associated computer-readable media may provide nonvolatile storage for a central server. It is important to note that the computer-readable media described above could be replaced by any other type of computer-readable media known in the art. Such media include, for example, magnetic cassettes, flash memory cards and digital video disks.

[00113] A number of program modules may be stored by the various storage devices and within RAM 530. Such program modules may include an operating system 550 and a plurality of one or more (N) modules 560. The modules 560 may control certain aspects of the operation of the central server 500, with the assistance of the processor 510 and the operating system 550. For example, the modules may include a measurement module 562 for measuring mechanical properties of a blood sample, a hemostatic index determination module 564 and a display module 566.

[00114] The flowchart and block diagrams, such as in Figs. 9 and 19, illustrate the architecture, functionality, and operation of possible implementations of systems, methods and computer program products according to various embodiments of the present invention. In this regard, each block in the flowchart or block diagrams may represent a module, segment, or portion of code, which comprises one or more executable instructions for implementing the specified logical function(s). It should also be noted that, in some alternative implementations, the functions noted in the block may occur out of the order noted in the figures. For example, two blocks shown in succession may, in fact, be executed substantially concurrently, or the blocks may sometimes be executed in the reverse order, depending upon the functionality involved. It will also be noted that each block of the block diagrams and/or flowchart illustration, and combinations of blocks in the block diagrams and/or flowchart illustration, can be implemented by special purpose hardware-based systems that perform the specified functions or acts, or combinations of special purpose hardware and computer instructions.

[00115]The corresponding structures, materials, acts, and equivalents of all means or step plus function elements in the claims below are intended to include any structure, material, or act for performing the function in combination with other claimed elements as specifically claimed. The description of the present invention has been presented for purposes of illustration and description, but is not intended to be exhaustive or limited to the invention in the form disclosed. Many modifications and variations will be apparent to those of ordinary skill in the art without departing from the scope and spirit of the invention. The embodiment was chosen and described in order to best explain the principles of the invention and the practical application, and to enable others of ordinary skill in the art to understand the invention for various embodiments with various modifications as are suited to the particular use contemplated.

CLAIMS

1. A system for displaying a hemostatic index, the system comprising:
a communication receiver configured to receive the hemostatic index; and
a graphical user interface (GUI) connected to the communication receiver and
configured to display a hemostatic index;
wherein the hemostatic index is derived from a plurality of independent
measurements.
2. A system of Claim 1, wherein the communication receiver is
configured to receive at least two hemostatic indexes and the GUI is configured to
display the at least two hemostatic indexes simultaneously.
3. A system of Claim 2, wherein at least one of the hemostatic indexes is
derived from a combination of at least two of the independent measurements.
4. A system of Claim 2, wherein each of the hemostatic indexes is
derived from a corresponding one of the independent measurements.
5. A system of Claim 2, wherein the independent measurement is a
measurement of mechanical properties.
6. A system of Claim 5, wherein the functional hemostasis indexes
include at least one of a group consisting of a coagulation factor function, a fibrinogen
concentration, a fibrinogen function, a platelet function and a fibrinolysis function.
7. A system of Claim 6, wherein the functional hemostasis indexes
include a numerical score.
8. A system of Claim 6, wherein the functional hemostasis indexes
include a graphical depiction.
9. A system of Claim 6, wherein the coagulation factor function includes
at least one of an intrinsic activation factor or an extrinsic activation factor.
10. A system of Claim 6, wherein the GUI is further configured to display
at least one of a group consisting of a hematocrit, hemoglobin concentration and red
cell count.
11. A system of Claim 10, wherein the GUI is further configured to
display the at least one of the group consisting of the hematocrit, hemoglobin
concentration and red cell count simultaneously with the at least two hemostatic
indexes.

12. A system of Claim 2, further comprising a consumable receptacle configured to receive a consumable holding at least two blood samples, wherein the blood samples are used to generate the independent measurements.
13. A system of Claim 12, wherein each of the blood samples is used to generate a corresponding one of the independent measurements.
14. A system of Claim 10, wherein the consumable receptacle is configured to position the at least two blood samples in a spatial arrangement corresponding to the display of the at least two hemostatic indexes.
15. A system of Claim 12, wherein the corresponding spatial arrangement includes a side-by-side serial arrangement of both the blood samples and the hemostatic indexes.
16. A system of Claim 2, wherein the GUI further comprises a visual element associating the display of each of the at least two hemostatic indexes with the at least two blood samples.
17. A system of Claim 14, wherein the visual element includes at least one of lines or colors.
18. A system of Claim 2, wherein the GUI is further configured to display a history of the hemostatic indexes.
19. A system of Claim 18, wherein the GUI is further configured to display a clinical intervention overlaid on the history.
20. A system of Claim 18, wherein at least one portion of the history includes an array of graphical indicators, each of the graphical indicators representing one of the hemostatic indexes at some time in the history.
21. A system of Claim 20, wherein the graphical indicators have relative positioning configured to communicate a hemostatic condition of a subject.
22. A system of Claim 2, wherein the GUI is further configured to display a treatment recommendation based on the at least two hemostatic indexes.
23. A system of Claim 22, wherein the treatment recommendation is for guiding transfusion of at least one of platelets, cryoprecipitate, plasma, red cells or antifibrinolytics.
24. A system of Claim 22, wherein the treatment recommendation is for guiding therapies of at least one of anti-platelet drug, anti-coagulant drug or pro-fibrinolysis drug.
25. A system of Claim 2, wherein GUI is configured to display

information for guiding transfusion or therapy.

26. A method comprising:
deriving a plurality of hemostatic indexes from a plurality of independent measurements; and
simultaneously displaying at least two of the hemostatic indexes.
27. A method of Claim 26, wherein deriving further comprises deriving at least one of the hemostatic indexes from a combination of at least two of the independent measurements.
28. A method of Claim 26, wherein deriving further comprises deriving each of the hemostatic indexes from a corresponding one of the independent measurements.
29. A method of Claim 26, further comprising measuring mechanical properties of a blood sample to generate the independent measurements.
30. A method of Claim 29, wherein deriving further comprises deriving at least one of a group consisting of a coagulation factor function, a fibrinogen concentration, a fibrinogen function, a platelet function and a fibrinolysis function.
31. A method of Claim 29, further comprising displaying a numerical score for the hemostatic indexes.
32. A method of Claim 30, further comprising displaying a graphical element for the hemostatic indexes.
33. A method of Claim 30, further comprising displaying at least one of an intrinsic activation factor or an extrinsic activation factor.
34. A method of Claim 33, further comprising displaying the at least one of a group consisting of the hematocrit, hemoglobin concentration and red cell count simultaneously with the at least two hemostatic indexes.
35. A method of Claim 26, further comprising displaying a history of the hemostatic indexes.
36. A method of Claim 35, further comprising displaying a clinical intervention overlaid on the history.
37. A method of Claim 35, wherein displaying the history includes displaying an array of graphical indicators, each of the graphical indicators representing one of the hemostatic indexes at some time in the history.
38. A method of Claim 35, further comprising positioning the graphical indicators relative to each other to communicate a hemostatic condition of a subject.

39. A method of Claim 26, further comprising displaying a treatment recommendation based on the at least two hemostatic indexes.
40. A method of Claim 39, further comprising guiding transfusion of at least one of platelets, cryoprecipitate, plasma, red cells or antifibrinolytics.
41. A method of Claim 39, further comprising guiding therapies of at least one of anti-platelet drug, anti-coagulant drug or pro-fibrinolysis drug.
42. A method of Claim 26, further comprising displaying information for guiding transfusion.
43. A system for measuring hemostatic characteristics of a blood sample, the system comprising:
- a processor configured to receive a data stream of measurements from a blood sample and to estimate a possible range of a functional hemostatic index based on the data stream; and
 - a graphical user interface (GUI) connected in communication with the processor and configured to display the possible range of the functional hemostatic index.
44. A system of Claim 43, wherein the measurements are measurements of stiffness.
45. A system of Claim 43, wherein the processor is configured to determine changes in the possible range as new data is received from the data stream.
46. A system of Claim 45, wherein the GUI is configured to dynamically adapt a graphical element to express the changes in the possible range.
47. A system of Claim 46, wherein the GUI is configured to expand or shrink the graphical element to express the changes in the possible range.
48. A system of Claim 47, wherein the GUI is configured to display a final indicator that shows a final value for the functional hemostatic index.

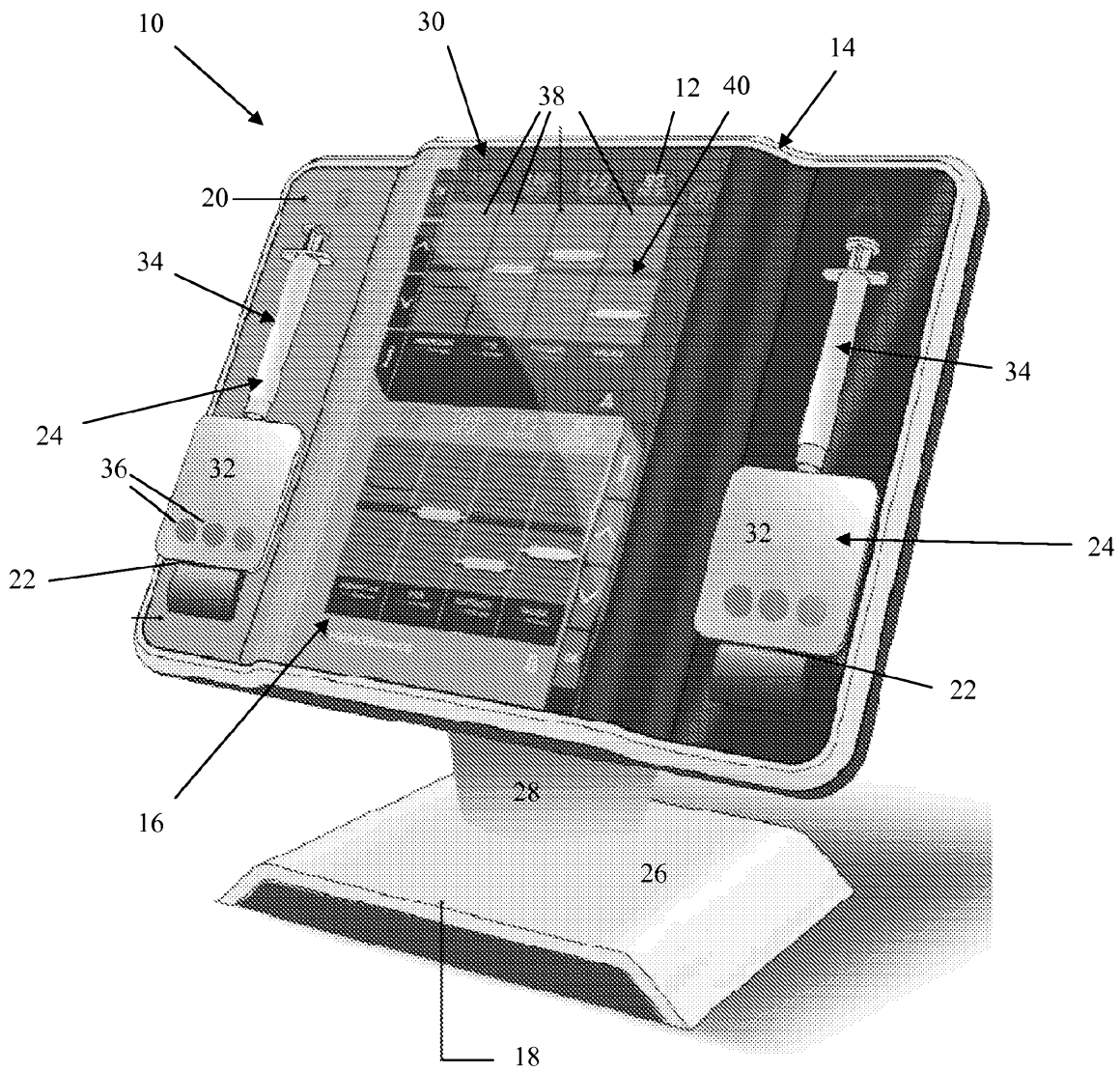

Fig. 1

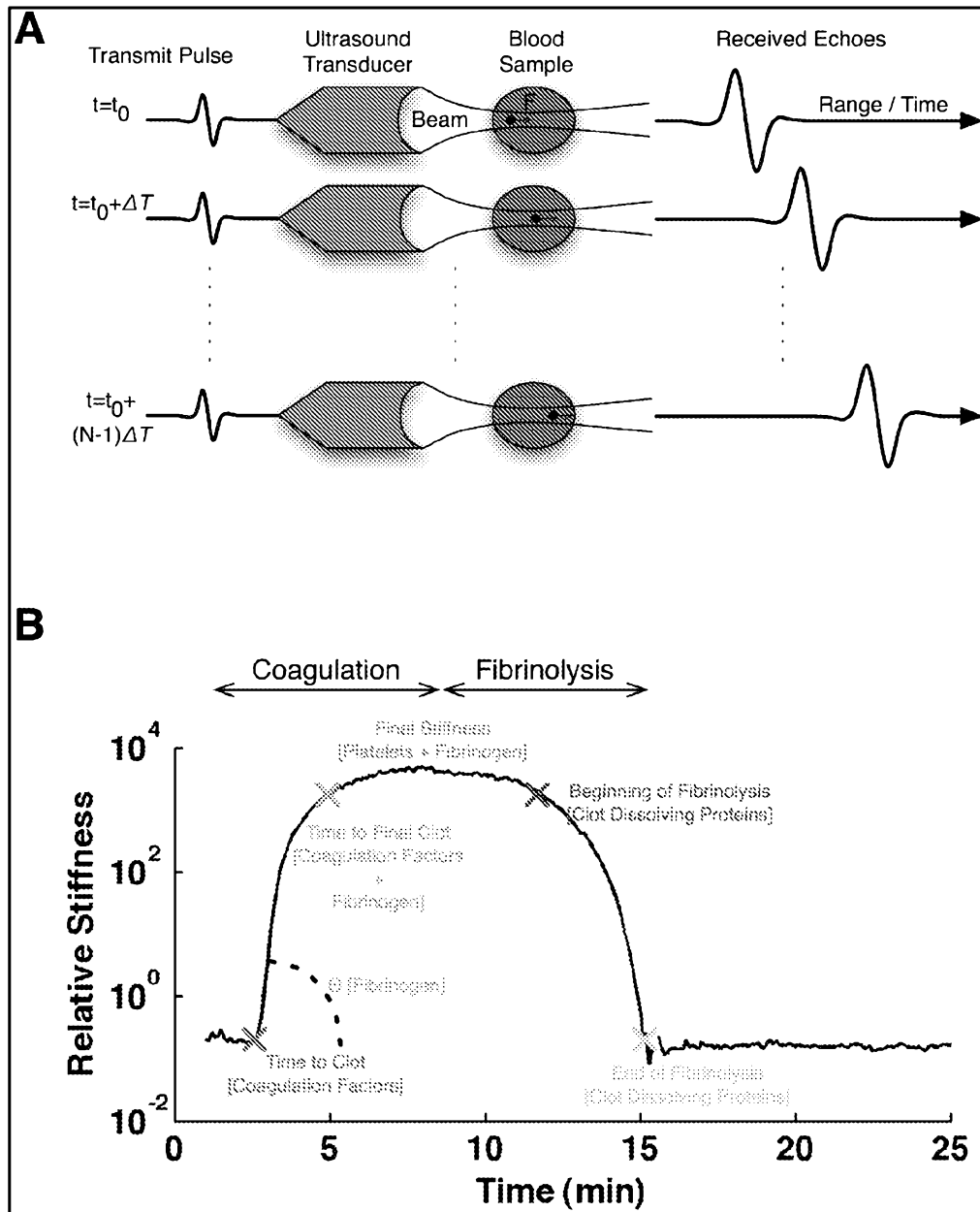
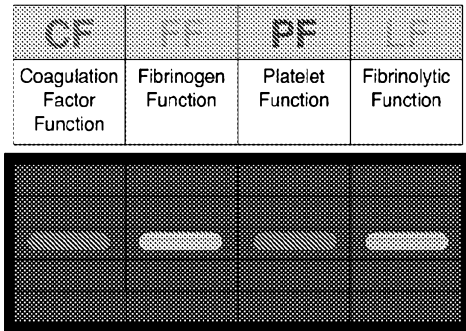
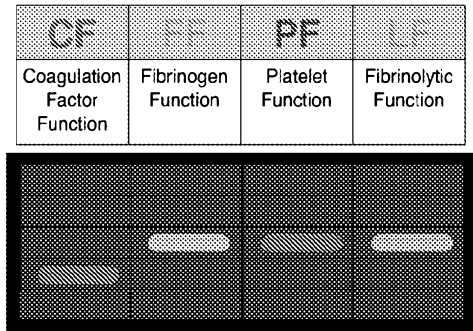

Fig. 2

(A) Normal



(B) Reduced Coag Factors Function



(C) Reduced Platelet Function

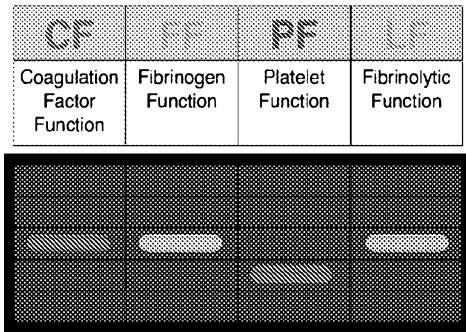

(D) Increased Fibrinolytic Function

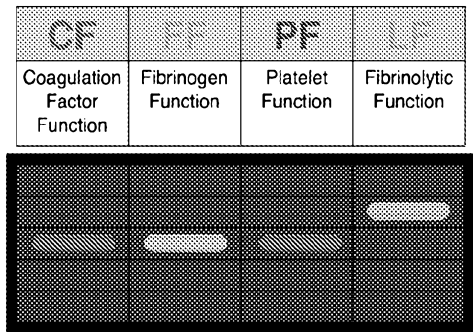

(E) Reduced Coagulation Factors and Platelet Function

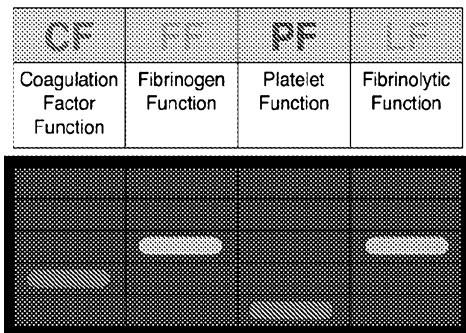

(F) Increased Coag Factors Function

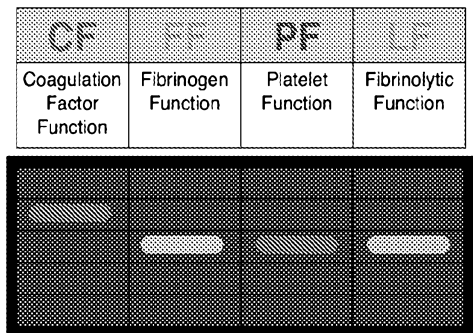

Fig. 3

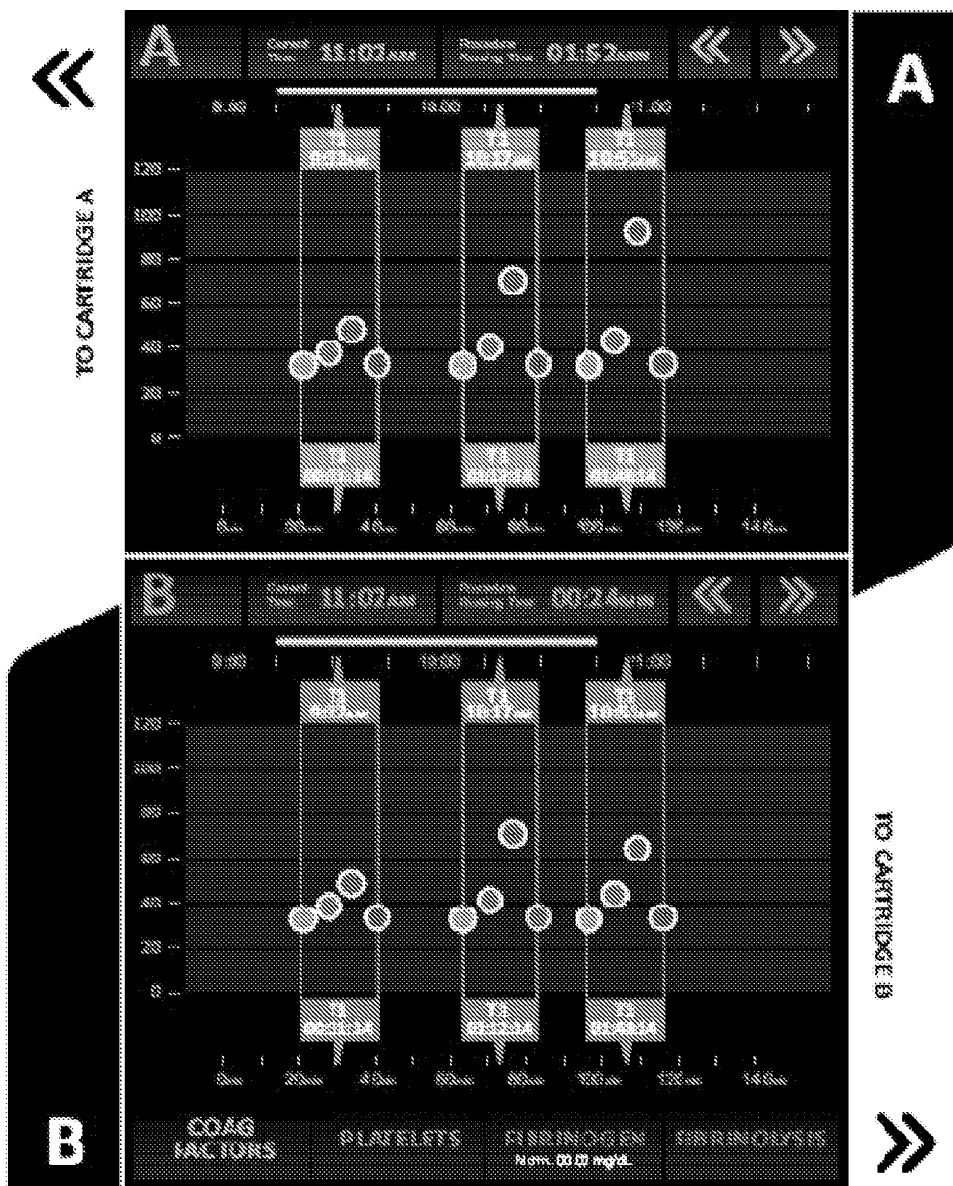

Fig. 4

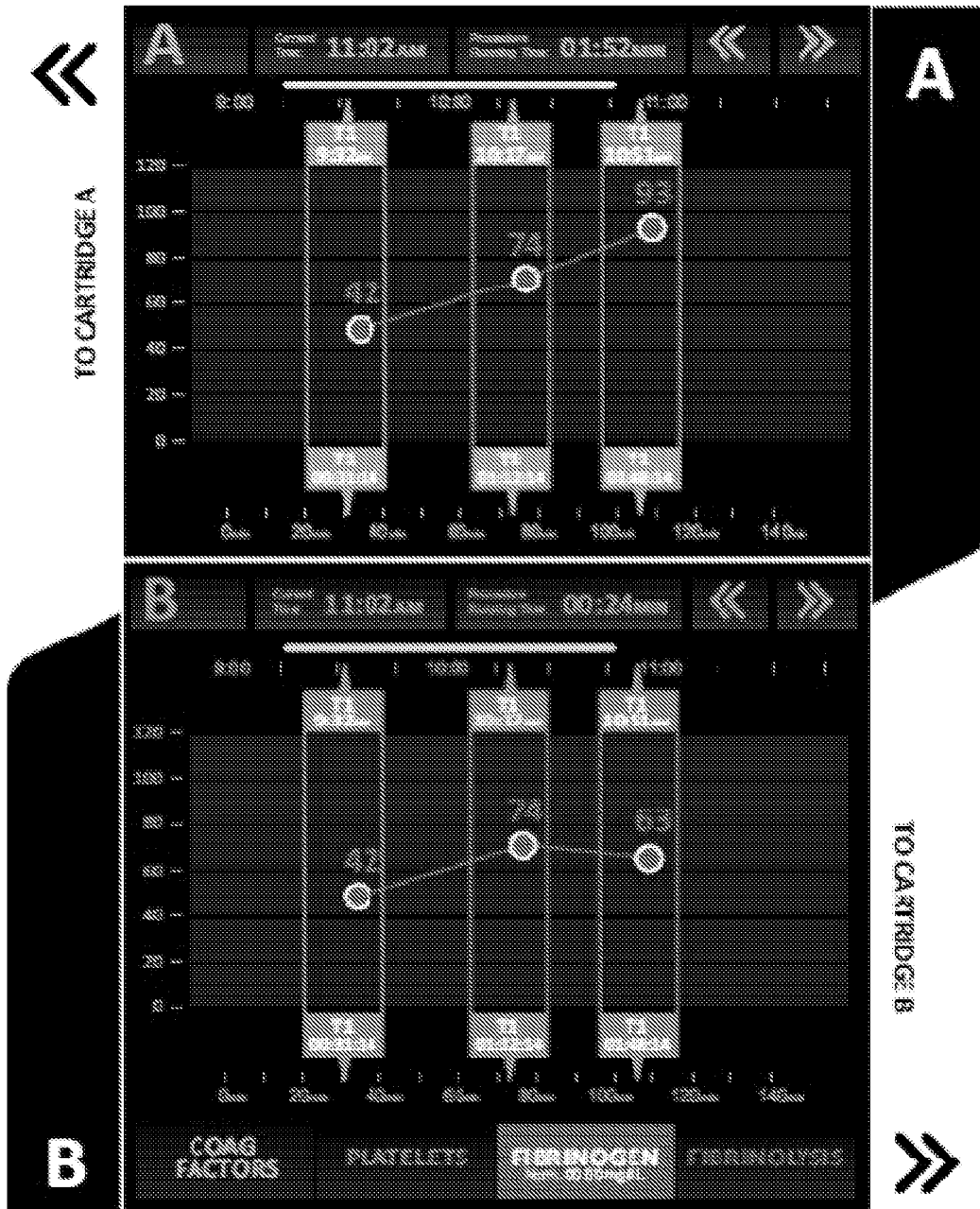

Fig. 5

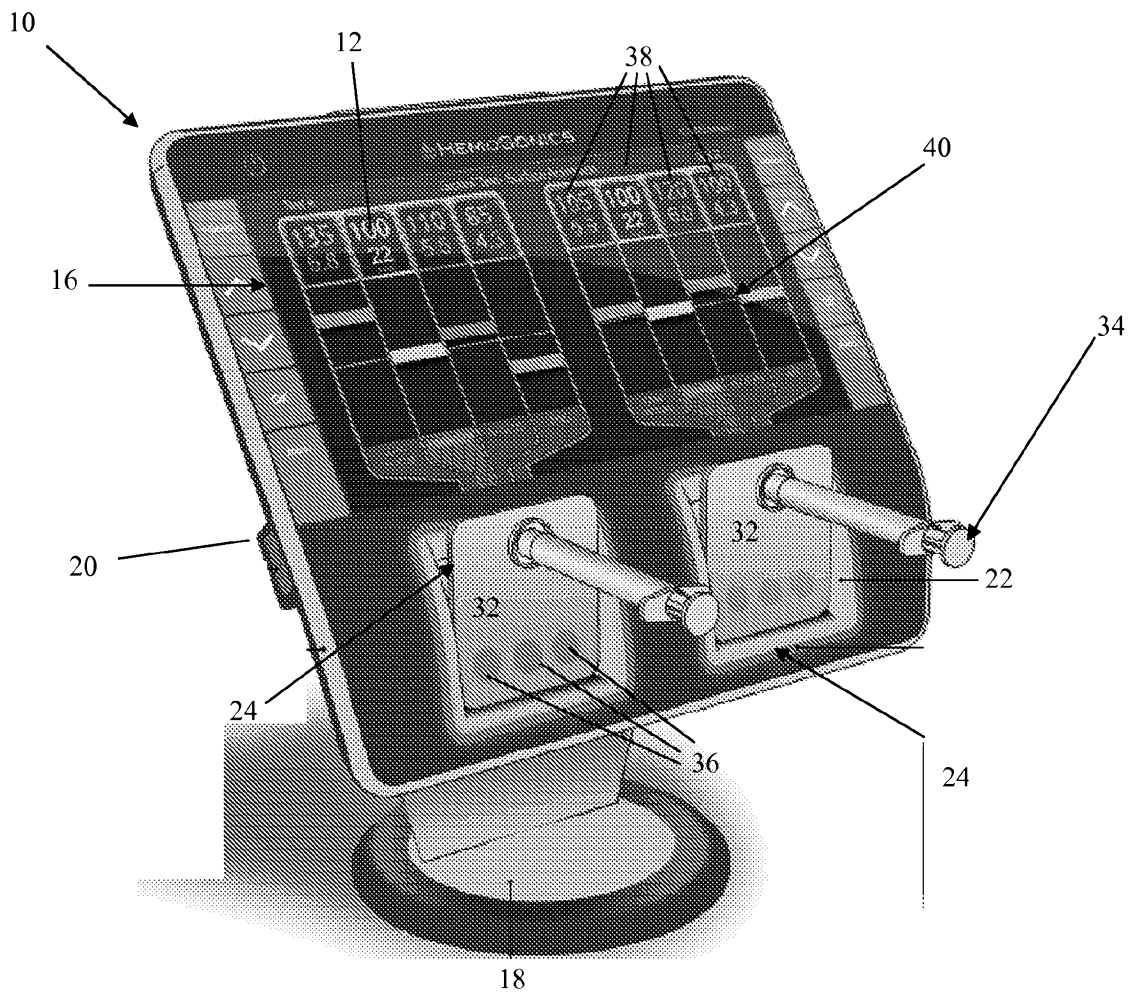

Fig. 6

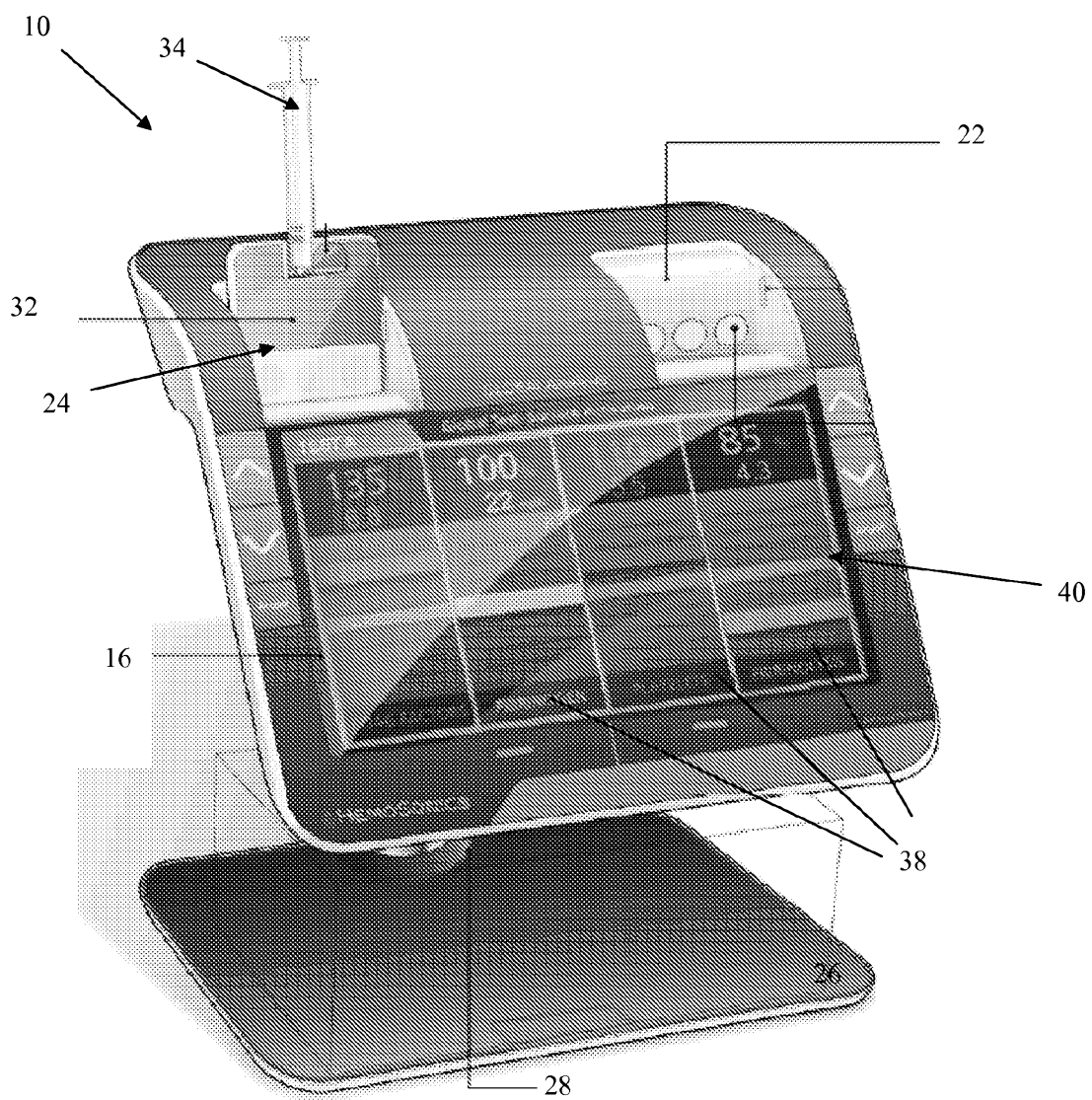

Fig. 7

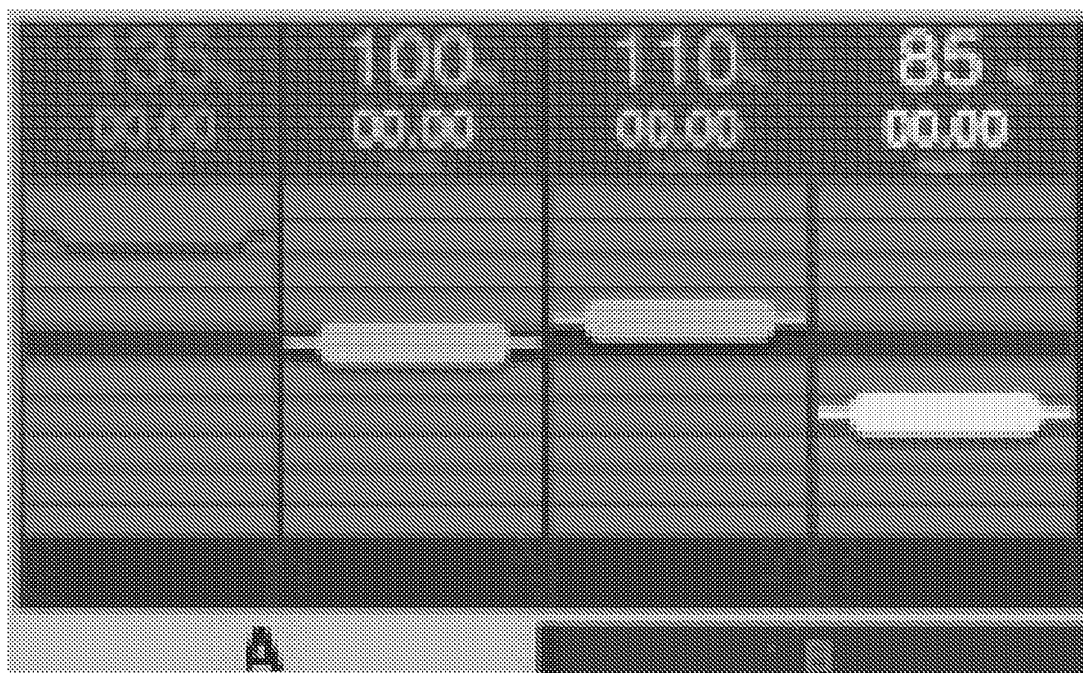
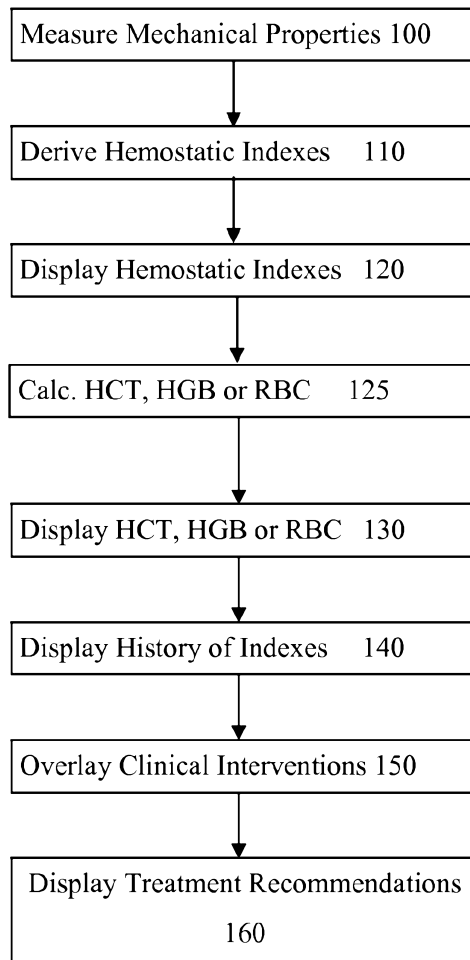

Fig. 8

Fig. 9



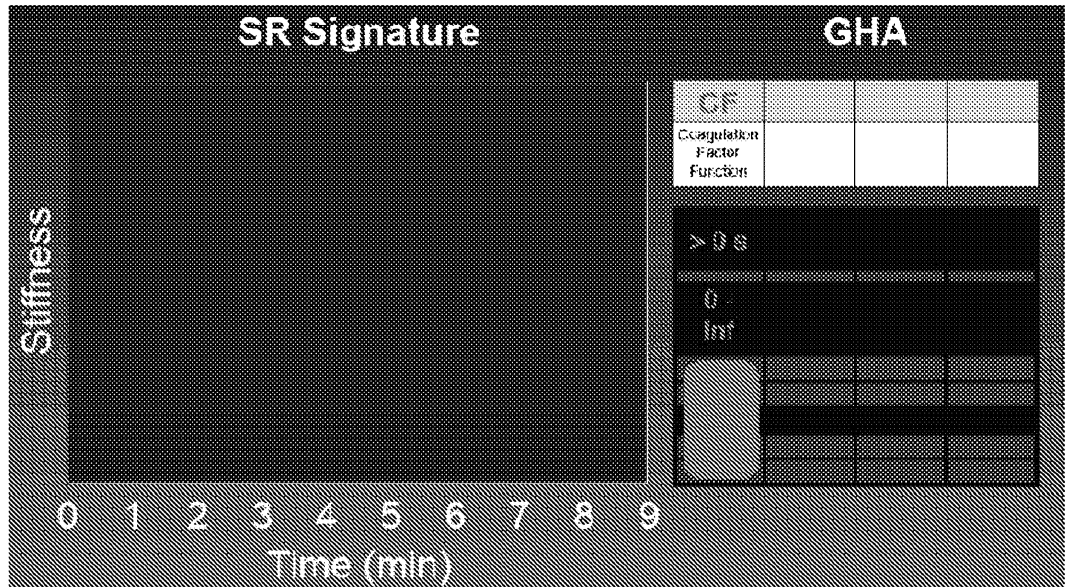

Fig. 10

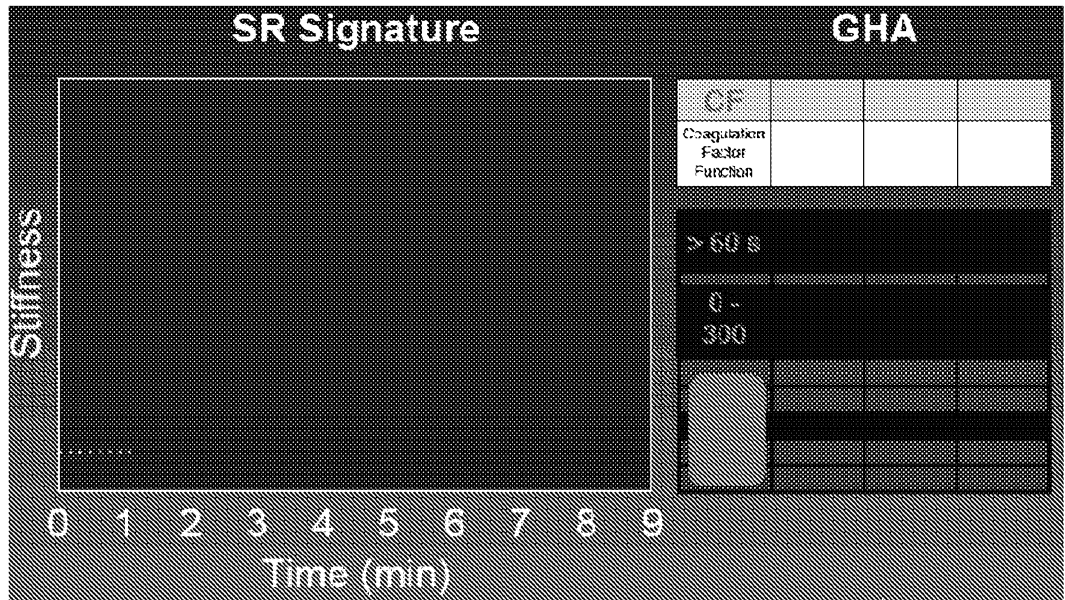

Fig. 11

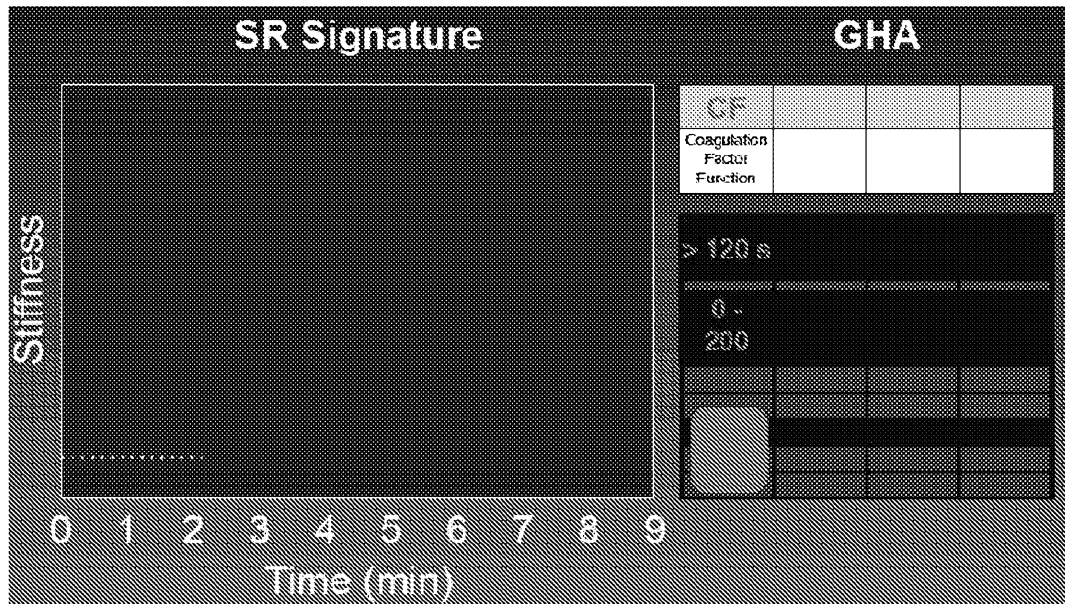

Fig. 12

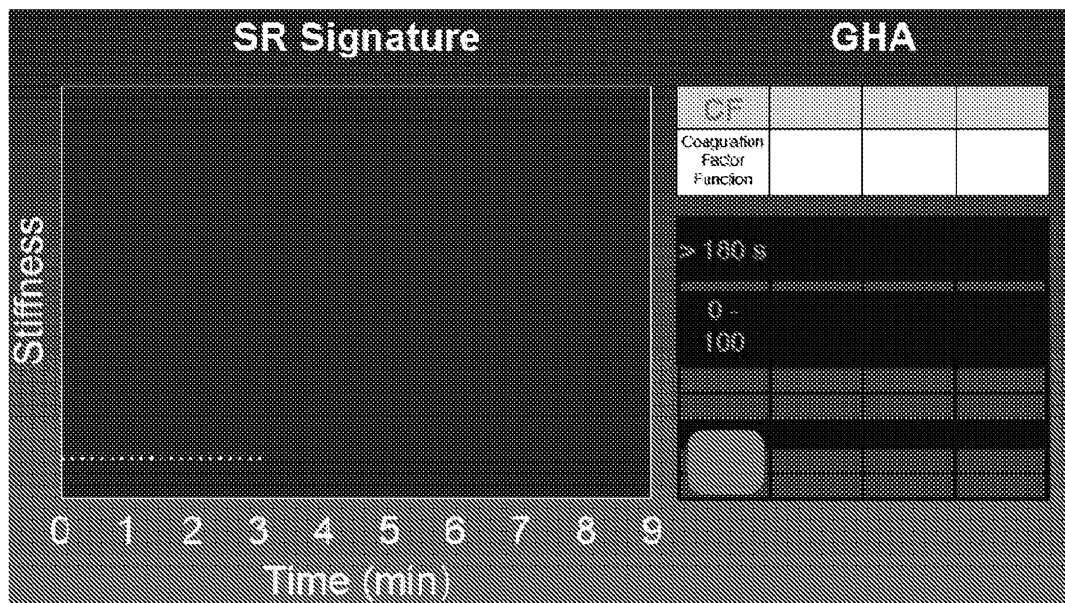

Fig. 13

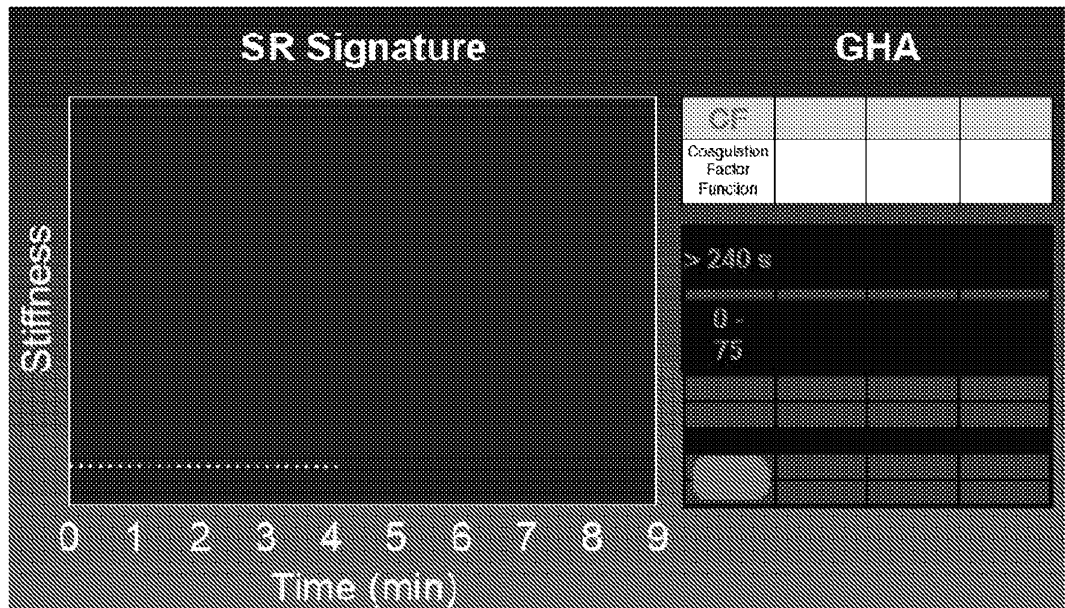

Fig. 14

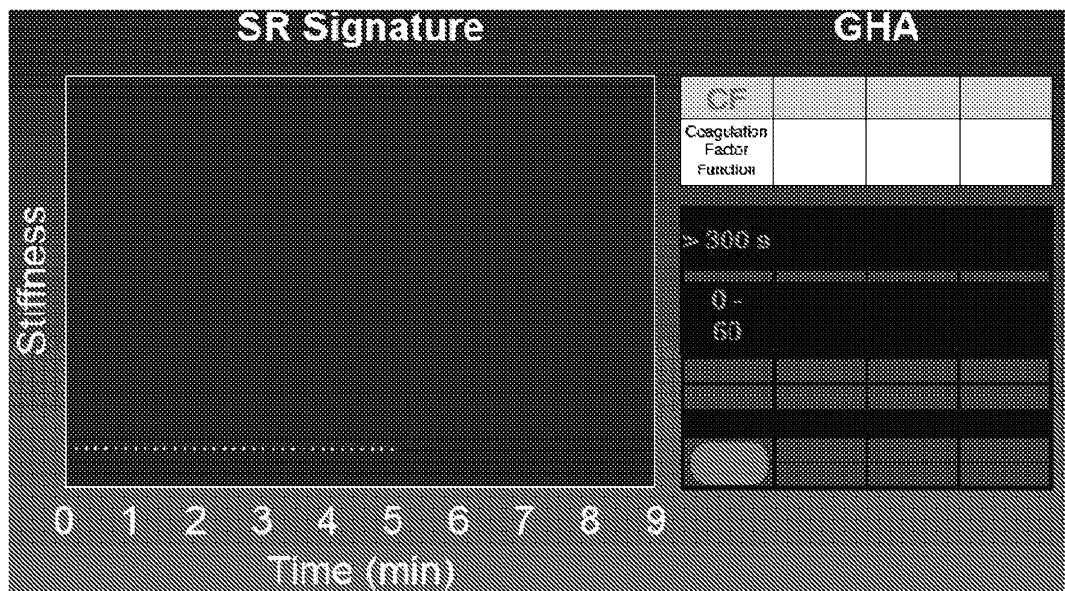

Fig. 15

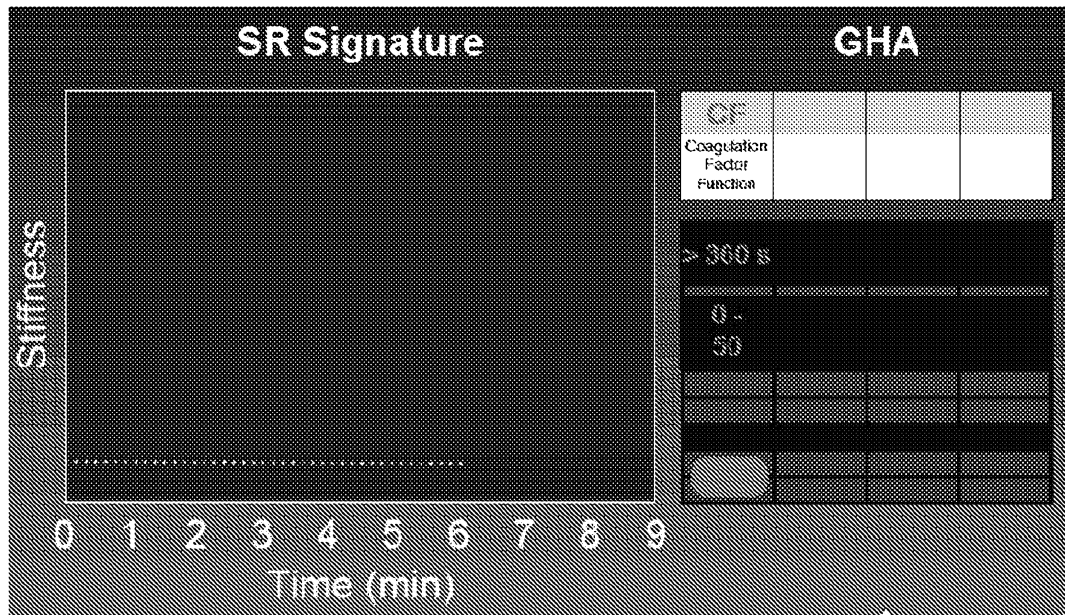

Fig. 16

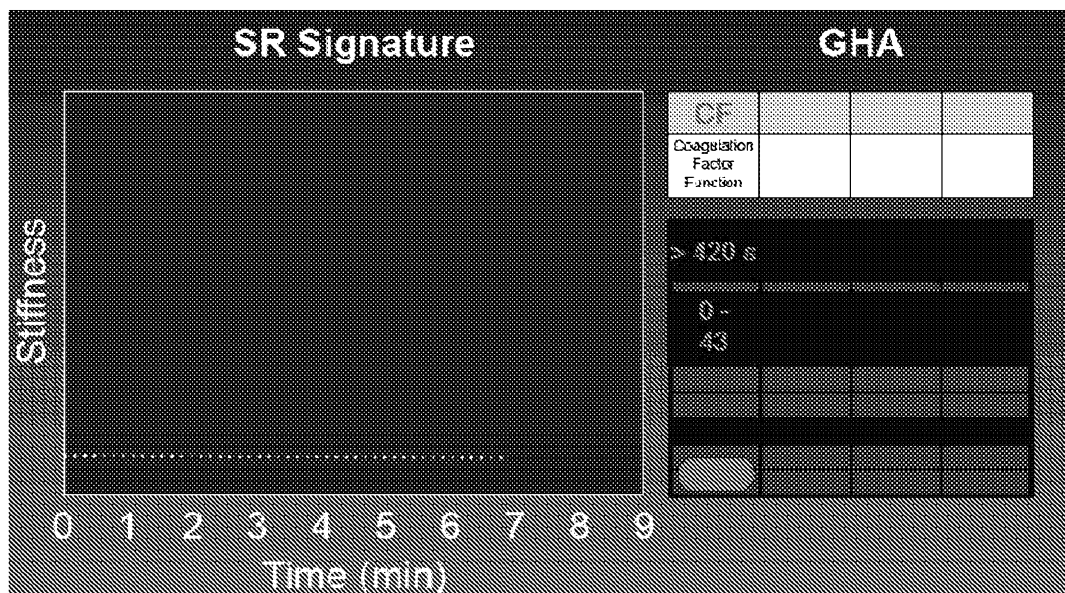

Fig. 17

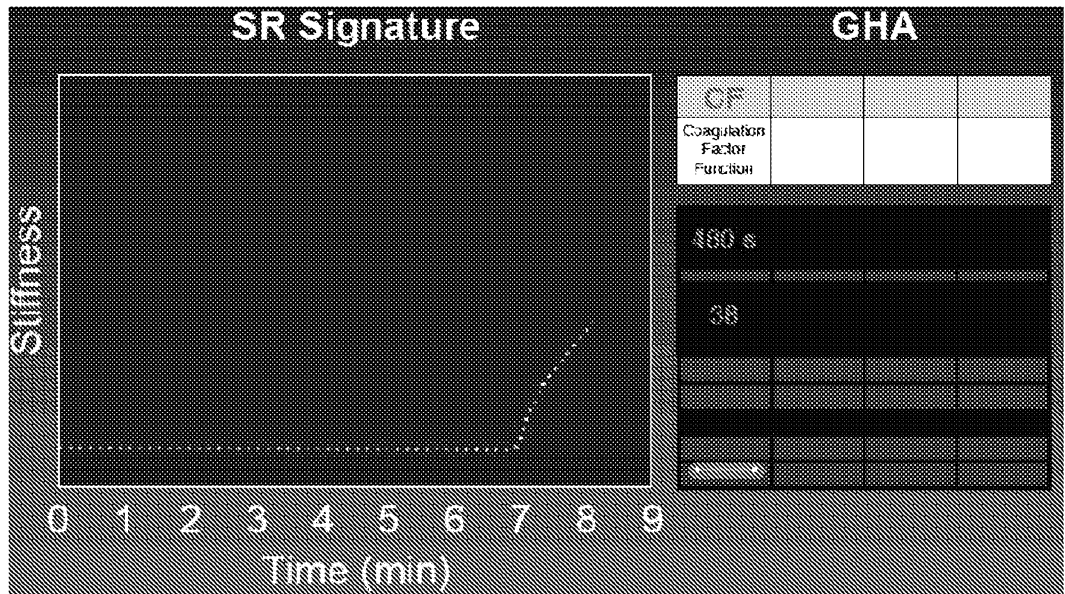

Fig. 18

Fig. 19

