

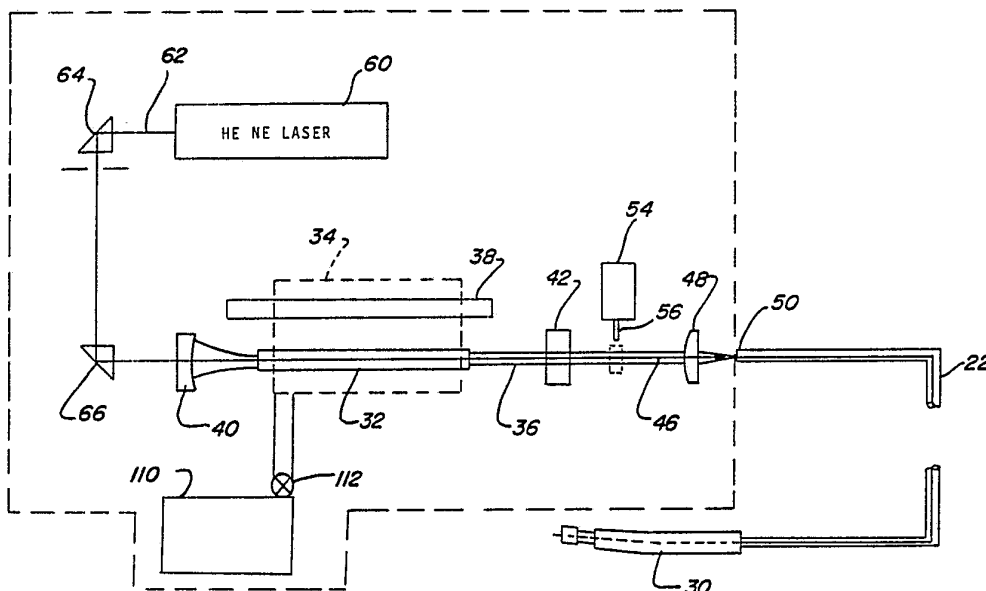

## INTERNATIONAL APPLICATION PUBLISHED UNDER THE PATENT COOPERATION TREATY (PCT)

(51) International Patent Classification <sup>4</sup> :  A61C 5/00	A1	(11) International Publication Number: WO 90/01907 (43) International Publication Date: 8 March 1990 (08.03.90)
<p>(21) International Application Number: PCT/US89/03825</p> <p>(22) International Filing Date: 25 August 1989 (25.08.89)</p> <p>(30) Priority data: 236,450 25 August 1988 (25.08.88) US 342,190 24 April 1989 (24.04.89) US</p> <p>(71)(72) Applicants and Inventors: VASSILIADIS, Arthur [US/US]; 707 Continental Circle 412, Mountain View, CA 94040 (US). HENNINGS, David, R. [US/US]; 190 Welcome Road, Newcastle, CA 95658 (US). SHAFFER, Joseph, W. [US/US]; 235 Vincent Drive, Mountain View, CA 94041 (US). FULLMER, David, J. [US/US]; 156 Rock Harbor Lane, Foster City, CA 94404 (US). BREWER, Michael, H. [US/US]; 8001 Pine Drive, Felton, CA 95018 (US). MYERS, Terry, D. [US/US]; 25334 Lyncastle, Farmington Hills, MI 48018 (US).</p>	<p>(74) Agent: SPRINKLE, Douglas, W.; Gifford, Groh, Sheridan, Sprinkle &amp; Dolgorukov, 280 North Woodward, Suite 210, Birmingham, MI 48009 (US).</p> <p>(81) Designated States: AT (European patent), AU, BE (European patent), CH (European patent), DE (European patent), FR (European patent), GB (European patent), IT (European patent), JP, KR, LU (European patent), NL (European patent), SE (European patent).</p> <p>Published <i>With international search report.</i></p>	

## (54) Title: DENTAL LASER ASSEMBLY



## (57) Abstract

A dental laser assembly (10) is disclosed for use in eradicating carious lesions in teeth, the treatment of sensitive teeth, as well as the removal of soft tissue. The laser assembly (10) includes a housing (12) having a cavity (34) in which a pulsed laser (32) is contained. The laser (32) is excited so that the laser (32) emits a laser beam along a predetermined axis (46) that is in line with a fiber optic delivery system (22) and at a pulse rate of 1 to 10,000 pulses per second and an average power variable from 0 to 50 watts. A handpiece (30) is dimensioned to be inserted into a human mouth while an optical fiber (22) optically connects the laser output to the handpiece. The laser assembly (10) also includes a continuous output aiming laser (60) which, upon activation, provides a continuous laser aiming beam coaxial to the treatment beam. Both beams are then introduced into a fiber optic delivery system.

***FOR THE PURPOSES OF INFORMATION ONLY***

Codes used to identify States party to the PCT on the front pages of pamphlets publishing international applications under the PCT.

AT	Austria	ES	Spain	MG	Madagascar
AU	Australia	FI	Finland	ML	Mali
BB	Barbados	FR	France	MR	Mauritania
BE	Belgium	GA	Gabon	MW	Malawi
BF	Burkina Fasso	GB	United Kingdom	NL	Netherlands
BG	Bulgaria	HU	Hungary	NO	Norway
BJ	Benin	IT	Italy	RO	Romania
BR	Brazil	JP	Japan	SD	Sudan
CA	Canada	KP	Democratic People's Republic of Korea	SE	Sweden
CF	Central African Republic	KR	Republic of Korea	SN	Senegal
CG	Congo	LI	Liechtenstein	SU	Soviet Union
CH	Switzerland	LK	Sri Lanka	TD	Chad
CM	Cameroon	LJ	Luxembourg	TG	Togo
DE	Germany, Federal Republic of	MC	Monaco	US	United States of America
DK	Denmark				

DENTAL LASER ASSEMBLYCROSS REFERENCE TO RELATED APPLICATIONS

This application is a continuation-in-part of U.S. Patent Application Serial No. 236,450, entitled  
5 DENTAL LASER ASSEMBLY, filed on August 25, 1988.

Background of the InventionI. Field of the Invention

The present invention relates generally to laser assemblies and, more particularly, to a laser  
10 assembly particularly suited for dental applications such as the eradication of carious lesions, the treatment of sensitive teeth, and the removal of soft tissue.

II. Description of the Prior Art

15 There have been a number of previously known Neodymium doped Yttrium Aluminum Garnet (Nd:YAG) laser systems that have been used for medical surgical applications. These previously known laser systems typically have been constructed to provide very high  
20 average powers, i.e. in the range of 60 to 100 watts of continuous power. Consequently, these previously known systems have required high power electrical supply systems, typically 220 volts.

25 There have been a number of disadvantages to these previously known Nd:YAG systems. One disadvantage is that these systems are heavy and difficult to move and also require substantial cooling systems in order to cool the laser head and the power supply. Furthermore, since such systems are typically  
30 powered by 220 volt line current, it has been necessary to install separate electrical receptacles for these previously known systems.

35 These previously known systems oftentimes use fiber optic delivery having a simple focusing lens at

-2-

the output from the fiber optic. In some systems, contact tips were used to deliver the laser power to the target site. These previously known delivery systems, however, had been somewhat bulky and difficult to use.

To date, there has never been a Nd:YAG laser system particularly suited for dental laser applications. Such applications include the eradication of carious lesions, the treatment of sensitive teeth, as well as the removal of soft tissue.

U.S. Patent No. 4,818,230 to Myers et al. is commonly owned with this patent and discloses a method for removing decay from teeth. In the Myers' patent, the power levels of the laser was limited to 100 millijoules per pulse for fear of causing pain for the patient by heating the tooth. New research and new applications, however, have made it necessary to consider higher powers and pulse repetition rates.

#### Summary of the Present Invention

The present invention provides a dental laser assembly which overcomes all of the above mentioned disadvantages of the previously known devices.

In brief, the dental laser assembly of the present invention comprises a housing having a cavity in which a pulsed Nd:YAG laser is contained. An exciting flash lamp is also contained within the cavity and, upon excitation, causes the laser to emit a pulsed laser beam along a predetermined axis. Preferably, the repetition rate for the laser is approximately one to 10,000 pulses per second and a duration at each pulse between several picoseconds and several milliseconds. The average power of the laser is between zero and 50 watts and is adjustable.

35

-3-

An optical fiber is connected through a coupling to the housing so that the axis of the optical fiber is coincidental with the axis of the laser beam output. The other end of the fiber optic is connected  
5 to an elongated handpiece. This handpiece preferably includes either a mirror assembly or an arcuate fiber optic segment so that the handpiece directs the laser beam in a direction substantially perpendicular to the axis of the handpiece. This allows the handpiece to be  
10 inserted and manipulated into the mouth of the patient and used in the fashion of a conventional dentist drill.

In addition, the laser assembly of the present invention comprises a continuous wave, low powered  
15 visible laser having its output coaxial with the output from the pulsed laser. The continuous wave laser is preferably a helium-neon (HeNe) laser so that its output is in the visible range of the human eye. The continuous wave laser thus provides an aiming beam for  
20 the laser since the output from the Nd:YAG laser is invisible.

In operation, upon excitation of the pulsed laser, the pulse laser generates an output capable of removing carious lesions, the treatment of sensitive  
25 teeth, as well as removing soft tissue. Furthermore, the optical segment on the handpiece is preferably removable for cleaning and sterilization and replaceable with different optical segments for different dental applications.

30 It has also been found that, by using relatively low laser powers, i.e. less than 100 millijoules per pulse, and lasing healthy enamel, desensitization of the tooth is achieved. This in turn permits higher energy levels per pulse to be utilized

35

without causing patient discomfort which, in turn, allows the dental procedure to be quickly accomplished.

Brief Description of the Drawing

5 A better understanding of the present invention will be had upon reference to the following detailed description when read in conjunction with the accompanying drawing, wherein like reference characters refer to like parts throughout the several views, and in which:

10 FIG. 1 is a view illustrating the main unit of a preferred embodiment of the laser assembly of the present invention;

FIG. 2 is a view illustrating the delivery system for the preferred embodiment of the invention;

15 FIG. 3 is a diagrammatic view illustrating the preferred embodiment of the present invention;

FIG. 4 is a side sectional view illustrating a preferred handpiece of the present invention;

20 FIG. 5 is a fragmentary sectional view similar to FIG. 4 but illustrating a different tip;

FIG. 6 is a view similar to FIG. 4 but illustrating still another further modification thereof;

25 FIG. 7 is a sectional view of an alternative embodiment of the cable and handpiece;

FIG. 8 is a fragmentary sectional view similar to FIG. 6 showing a further alternative embodiment of the tip;

30 FIG. 9 is a crosssectional view of a tooth; and

FIG. 10 is a crosssectional view illustrating an endontic procedure.

-5-

Detailed Description of Preferred  
Embodiments of the Present Invention

With reference first to FIGS. 1 and 2, a preferred embodiment of the dental laser assembly 10 of the present invention is thereshown and comprises a main unit 12 and the fiber optic laser beam delivery system 14. The main unit 12 preferably includes rollers 16 at one end for mobility so that the main unit 12 can be moved as desired. The other end of the main unit rests on posts 17. The unit is lifted with a retractable handle 19 so as to be moved on the rollers 16.

Still referring to FIGS. 1 and 2, the main unit 12 includes a fiber optic output connector 26 along one side. A control panel 20 is provided at the top of the main unit 12 to control the activation and use of the dental laser system 10.

Referring still to FIGS. 1 and 2, the fiber optic cable assembly comprises an elongated fiber optic 22 which is flexible. One end 24 of the fiber optic 22 is received within the fiber optic connector 26. A lock nut 28 adjacent the end 24 of the fiber optic 22 locks to the connector 18 in order to secure the fiber optic 22 to the main unit 12 for a reason to be subsequently described.

Referring now particularly to FIG. 2, a handpiece 30 is provided at the opposite end 75 of the fiber optic cable 22. As will be subsequently described in greater detail, the fiber optic cable 22 delivers a laser beam from the end 24 and to the handpiece 30.

With reference particularly to FIG. 3, an Nd:YAG laser 32 is contained within a cavity 34 in the main unit 12. The YAG laser 32 is positioned within

35

-6-

the cavity 34 so that the laser 32 generates a laser output beam along a predetermined axis 36. Any conventional means, such as a flash lamp 38, is also contained within the cavity 34 to excite the laser 32 so that the laser 32 generates a pulsed output.

The YAG laser has a pulse repetition rate of between one and 10,000 pulses/sec., an average power of up to 50 watts, a pulse duration of between a picosecond and several milliseconds and a peak energy of up to five joules/pulse. The peak power will vary depending upon the pulse duration and pulse energy and, similarly, the average power will vary depending upon the energy of each pulse, and the repetition rate. However, since the output power of the laser is less than 50 watts, the laser can be operated from a standard 110 volt electrical power supply and without the necessity of an external cooling system to cool the laser cavity 34.

Conventional electronics operated through the control panel 20 enable the average power, pulse energy, and pulse repetition rate to be user selected. These factors will vary in dependence upon the dental procedure involved as subsequently discussed.

Still referring to FIG. 3, a reflecting mirror 40 is positioned adjacent one end of the laser 32 while a semi-reflective mirror 42 is positioned adjacent the other end of the laser 32. The mirrors 40 and 42 thus cause the laser 32 to generate an output along the axis 46, through a fiber focus lens 48 and into one end 50 of the fiber optic 22. The fiber optic 22 then carries or delivers the laser output from the laser 32 to the handpiece 30 which will be subsequently described in greater detail.

35



-7-

A shutter solenoid 54 is also preferably contained within the main housing 12 and operates a movable shutter 56 (illustrated only diagrammatically). With the shutter 56 in its upper or retracted position, illustrated in solid line, the laser beam from the laser 32 passes through the lens 48 and out through the fiber optic 22. Conversely, with the shutter 56 in its extended position, illustrated in phantom line, the shutter 56 blocks the output from the laser 32 to prevent unintended laser outputs from the handpiece 30.

Still referring to FIG. 3, the main unit 12 also includes a continuous wave laser 60, such as a helium-neon (HeNe) laser. Such a laser provides a very low power output but, unlike the Nd:YAG laser 32, the output from the helium-neon laser 60 is in the visible range.

The output 62 from the HeNe laser 60 is reflected by prisms 64 and 66 through the mirror 40 so that the HeNe laser output 62 is coaxial with the axis 36 and thus with the laser outputs from the Nd:YAG laser 32. Thus, both the laser output from the continuous laser 60 as well as the pulse laser 32 are delivered through the fiber optic cable 22 to the handpiece 30. The continuous laser output 62 provides an aiming output since the output from the pulse laser 32 is invisible.

Other means for aiming the pulsed laser can, of course, be alternatively used.

The main housing further includes a cooling system 110 for cooling the pulsed laser 32. The cooling system can be of any conventional construction, for example, having a coolant of 50% ethylene glycol and 50% deionized water. This coolant is pumped by a pump while a flowmeter 112 monitors the flow of the

35

-8-

coolant. The fluid is pumped through the laser cavity and through a radiator and then circulated. In the event that the flow of the coolant is interrupted, the laser 32 is deactivated in order to prevent the laser 32 from overheating.

5 With reference now particularly to FIG. 4, one preferred embodiment of the handpiece 30 is thereshown and comprises an elongated body 70 having a first end 72 and a second end 74. The fiber optic cable 22  
10 extends through the handpiece body 70 from the end 72 and terminates at a point 76 short of the handpiece end 74. The output from the end 75 of the fiber optic is concentrated by a collimating lens 78 to a mirror 80. The mirror 80 reflects the laser output substantially  
15 at a right angle to the axis of the handpiece body 70, through a lens 81 and a protective window 82 and so that the laser output focuses at a point 84 adjacent to the output window 82 of the handpiece body 70.

20 Preferably, the handpiece 30 is of substantially the same shape and size as a conventional dentist drill. As such, the handpiece body 70 can be easily manipulated in the mouth of the patient in the same fashion as a dental drill.

25 In operation, upon activation of both lasers 60 and 32, both the continuous wave from the laser 60 as well as the pulsed output from the laser 32 are delivered through the fiber optic 22, through the collimating lens 78 (FIG. 4), mirror 80, focusing lens 81 and window 82 so that both lasers focus at the point  
30 84. Since only the output from the continuous wave laser 60 is in the visible range, the laser beams can be easily focused since the size of the visible laser 60 is smallest at the point 84. When the laser is properly focused, activation of the pulse laser 32  
35

removes the carious lesions, or the soft tissue as the case may be. Furthermore, the laser beam simultaneously sterilizes the work area during use which is particularly advantageous for the removal of soft tissue and dental decay.

The actual power and energy levels used by the operator or dentist will vary depending upon the desired dental procedure. It has been found, for example, that lasing the enamel of a healthy tooth with relatively low energy levels, e.g. less than 100 millijoules per pulse, desensitizes the tooth by temporarily sealing or otherwise deactivating the dentinal tubules which normally carry the pain signals of the tooth.

With the tooth desensitized, higher energy levels, i.e. energy levels between 100 millijoules and five joules per pulse, can be used without causing patient discomfort. Since higher energy levels per laser pulse eradicate more dental decay, disease, soft tissue and the like per pulse than laser pulses of lower energy, i.e. less than 100 mj/pulse, the overall dental procedure can be accomplished more quickly. This, in turn, saves "chair time" for the dentist and also is psychologically less stressful and less painful for the patient.

The average power required for soft tissue procedures is higher than for tooth procedures, and requires higher pulse repetition rates. Accordingly, a variable pulse repetition rate is provided to provide a smoother output and a higher average power.

External cooling of the tooth may also be necessary at high average power levels as well as at high energy/pulse levels. Such tooth cooling can be accomplished in any conventional fashion, such as by

-10-

spraying water on the tooth from a source 200 (FIG. 3). Since certain types of laser emissions are absorbed by water, a drying means 202, such as an air sprayer, is activated after each water spray but prior to a  
5 subsequent activation of the pulsed laser.

It has also been found that high energy levels, i.e. energy levels between 100 millijoules/pulse and five joules/pulse, are useful for endontic procedures such as root canals, apicoectomies  
10 and pulpectomies on a tooth 200 shown in FIGS. 9 and 10. The tooth 200 has an enamel outer shell 202, dentin 204 and a pulp chamber 206. In such endontic procedures, the pulp chamber is opened at 210 (FIG. 10) and a laser tip 212 is inserted. Activation of the  
15 laser at high power and/or energy levels eradicates the soft tissue in the pulp chamber 206 as desired. Simultaneously, the laser sterilizes the pulp chamber 206 and prevents infection. Due to this sterilization, a partial pulpectomy, previously unknown, is possible  
20 without risk of infection of the pulp chamber.

These relatively high power and/or energy levels have also proven useful for performing curetage. Tumors and other growths can also be excised using such high powers.

25 With reference now to FIG. 5, a modification of the handpiece is there shown in which the end 74' of the handpiece body 30' includes an internally threaded bore 90. This bore 90 detachably receives an externally threaded tip 92. The tip 92 includes an  
30 elongated throughbore 94 in which an arcuate fiber optic segment 96 is contained. The fiber optic segment 96 is arranged in the tip 92 so that one end 98 is aligned with the end 75 of the fiber optic 22 so that the laser output from the fiber optic 22 passes through  
35

-11-

the fiber optic 96 to its external end 100. The external end 100 of the fiber optic segment 96 is preferably a contact point so that the laser output is focused at the end 100 of the fiber optic segment 96. Also, as shown in FIG. 5, the fiber optic segment 96 is preferably arcuate so that the contact end 100 is substantially at a right angle from the axis of the handpiece body 30'.

With reference now to FIG. 6, a modification of the tip 92 is thereshown in which the throughbore 94' is linear rather than arcuate as shown in FIG. 5. Consequently, the contact end 100' of the fiber optic segment 96' is aligned with the axis of the handpiece body 30'. In all other respects, however, the tip 92' shown in FIG. 6 is the same as the tip 92 shown in FIG. 5 and, for that reason, will not be again described.

With reference to FIG. 7, another embodiment of a delivery system is shown. This comprises a single fiber 22 throughout and from input to output ends. A simple handpiece 98 is used to hold the fiber for use in the mouth.

With reference to FIG. 8, another embodiment of a tip 101 is shown that is designed to fit on the body 30'. The tip 101 is made of a ceramic material that acts as a thermal insulator. A metal heating tip 102 is mounted in the tip 101 to extend from the distal end of the cable 22. The laser beam is delivered to the heating tip by the cable 22 to exit the distal end of the cable to strike the heating tip 102. The heating tip is made of a suitable material such as stainless steel which may be heated quickly to a high temperature and then used to cut and cauterize soft tissue in the mouth.

35

-12-

Other configurations of tips 92 which are interchangeable with the tips 92 or 92' shown in FIGS. 5 and 6 are also possible.

From the foregoing, it can be seen that the present invention provides a simple and yet highly effective dental laser system for removing carious lesions, enamel and soft tissue as well as sterilization and other dental procedures. The laser can also be used in endodontic applications for eradicating diseased nerve tissue as well as sterilizing the root canal. There are many advantages to the dental laser system of the present invention.

First, the dental laser system of the present invention is not only portable but it can also be operated from standard line current of 110 volts. As such, special electrical wiring is not required in order to utilize the dental laser system of the present invention.

A still further advantage of the dental laser system of the present invention is that the delivery system utilizes a handpiece dimensioned to simulate the conventional dental handpiece used by dentists. As such, the handpiece of the present invention can be easily maneuvered in the patient's mouth. Furthermore, the replaceable tips for the handpiece further enhance the flexibility of the operation and use of the dental laser of the present invention.

Having described our invention, many modifications thereto will become apparent to those skilled in the art to which it pertains without deviating from the spirit of the invention as defined by the scope of the appended claims.

We claim:

35

CLAIMS

1           1. A laser assembly for dental applications  
2 comprising:  
3           a housing;  
4           a laser module comprising a pulsed laser for  
5 dental treatment, an optical resonator, means for  
6 aiming said pulsed laser, means for determining beam  
7 energy, and beam coupling optics;  
8           means for cooling said laser module;  
9           a laser power supply;  
10          electronics module means for controlling said  
11 laser module; and  
12          a flexible means of beam delivery into a human  
13 mouth,  
14          wherein said electronics module comprises  
15 means for adjusting the power level of the pulsed  
16 laser.

1           2. The invention as defined in claim 1  
2 wherein said pulsed laser is a Nd:YAG laser.

1           3. The invention as defined in claim 1  
2 wherein said laser is a Holmium doped laser.

1           4. The invention as defined in claim 1  
2 wherein said laser is an Erbium doped laser.

1           5. The invention as defined in claim 1  
2 wherein said pulsed laser has an average output of  
3 between 0 watt and 50 watts and a pulse duration of  
4 between several picoseconds and several milliseconds.

1           6. The invention as defined in claim 1  
2 wherein said pulsed laser has a pulse repetition rate  
3 of between 1 and 10,000 pulses per second.

1           7. The invention as defined in claim 1  
2 wherein said optical delivery means comprises optical  
3 fiber with at least one flexible portion and a  
4 handpiece.

1           8. The invention as defined in claim 1  
2 wherein said handpiece is elongated, said optical fiber  
3 being connected to one end, and means at the other end  
4 of said handpiece for directing said laser beam  
5 substantially 90° with respect to the axis of said  
6 handpiece.

1           9. The invention as defined in claim 8  
2 wherein said directing means comprises a mirror in said  
3 handpiece.

1           10. The invention as defined in claim 8  
2 wherein said directing means comprises an arcuate  
3 optical fiber.

1           11. The invention as defined in claim 1  
2 wherein said handpiece is elongated, said optical fiber  
3 being connected to one end of said handpiece, a tip  
4 having an optical fiber segment, means for detachably  
5 connecting said tip to the other end of said handpiece.

1           12. The invention as defined in claim 1 and  
2 comprising means for cooling a treatment area subjected  
3 to laser impingement.



-15-

1           13. The invention as defined in claim 12  
2 wherein said cooling means comprises means for spraying  
3 water on the treatment area and means for thereafter  
4 drying said treatment area prior to a subsequent  
5 activation of the pulsed laser.

1           14. The invention as defined in claim 1  
2 wherein said laser has an energy output between 0.1  
3 millijoules per pulse and 5 joules per pulse.

1           15. A method for performing a root canal  
2 procedure on a tooth, said tooth having a pulp chamber,  
3 comprising the steps of:  
4           opening a hole in said tooth to said pulp  
5 chamber,  
6           aiming a pulsed laser so that the output from  
7 the laser impinges upon pulp contained within the pulp  
8 chamber,  
9           repeatedly activating the laser until the pulp  
10 in the pulp chamber is eradicated,  
11           wherein said laser has an energy output per  
12 pulse sufficient to both eradicate pulp contained in  
13 the pulp chamber and to sterilize the pulp chamber.

1           16. The invention as defined in claim 15  
2 wherein said laser has an energy output of between 0.1  
3 millijoules per pulse and 5 joules per pulse.

1           17. The invention as defined in claim 15  
2 wherein the average power of said laser is between one  
3 and fifty watts.

1           18. The invention as defined in claim 15  
2 wherein the laser has a pulse repetition rate of  
3 between one and 10,000 pulses per second.

-16-

1           19. A method for performing an apicoectomy  
2 procedure on a tooth, said tooth having a pulp chamber,  
3 comprising the steps of:

4           opening a hole in said tooth to said pulp  
5 chamber,

6           aiming a pulsed laser so that the output from  
7 the laser passes through an apic contained at a bottom  
8 of the pulp chamber,

9           repeatedly activating the laser until the apic  
10 is eradicated,

11           wherein said laser has an energy output per  
12 pulse sufficient to both eradicate diseased tissue  
13 beneath the apic at the base of the pulp chamber and to  
14 sterilize the area surrounding the diseased tissue.

1           20. The invention as defined in claim 19  
2 wherein said laser has an energy output of between 0.1  
3 millijoules per pulse and 5 joules per pulse.

1           21. The invention as defined in claim 19  
2 wherein the average power of said laser is between one  
3 and fifty watts.

1           22. The invention as defined in claim 19  
2 wherein the laser has a pulse repetition rate of  
3 between one and 10,000 pulses per second.

1           23. A method for performing curetage  
2 procedure on diseased tissue in a gum area adjacent a  
3 tooth, said gum area being between a gum flap and a  
4 tooth, comprising the steps of:

5           moving said gum flap away from said tooth to  
6 provide access to said gum area,

-17-

7           aiming a pulsed laser so that the output from  
8 the laser impinges upon the diseased tissue in the gum  
9 area contained under the gum flap,  
10           repeatedly activating the laser until the  
11 diseased tissue in the gum area is eradicated,  
12           wherein said laser has an energy output per  
13 pulse sufficient to both eradicate diseased tissue  
14 contained in the gum area and to sterilize the gum  
15 area.

1           24. The invention as defined in claim 23  
2 wherein said laser has an energy output of between 0.1  
3 millijoules per pulse and 5 joules per pulse.

1           25. The invention as defined in claim 23  
2 wherein the average power of said laser is between one  
3 and fifty watts.

1           26. The invention as defined in claim 23  
2 wherein the laser has a pulse repetition rate of  
3 between one and 10,000 pulses per second.

1           27. A method for eradicating diseased soft  
2 tissue contained in a mouth, comprising the steps of:  
3           aiming a pulsed laser so that the output from  
4 the laser impinges upon the diseased soft tissue,  
5           repeatedly activating the laser until the  
6 diseased soft tissue in the mouth is eradicated,  
7           wherein said laser has an energy output per  
8 pulse sufficient to both eradicate the diseased soft  
9 tissue contained in the mouth and to sterilize the area  
10 around the diseased soft tissue,  
11           wherein said laser has an energy output of  
12 between 0.1 millijoules per pulse and 5 joules per  
13 pulse.

1           28. The invention as defined in claim 27  
2 wherein the average power of said laser is between one  
3 and fifty watts.

1           29. The invention as defined in claim 27  
2 wherein the laser has a pulse repetition rate of  
3 between one and 10,000 pulses per second.

1           30. A method for cutting out soft tissue  
2 contained in a mouth, comprising the steps of:  
3           aiming a pulsed laser so that the output from  
4 the laser impinges upon the diseased soft tissue,  
5           repeatedly activating the laser until the  
6 diseased soft tissue in the mouth is eradicated,  
7           wherein said laser has an energy output per  
8 pulse sufficient to both cut out the soft tissue  
9 contained in the mouth and to sterilize the area around  
10 the diseased soft tissue,  
11           wherein said laser has an energy output of  
12 between 0.1 millijoules per pulse and 5 joules per  
13 pulse.

1           31. The invention as defined in claim 30  
2 wherein the average power of said laser is between one  
3 and fifty watts.

1           32. The invention as defined in claim 30  
2 wherein the laser has a pulse repetition rate of  
3 between one and 10,000 pulses per second.

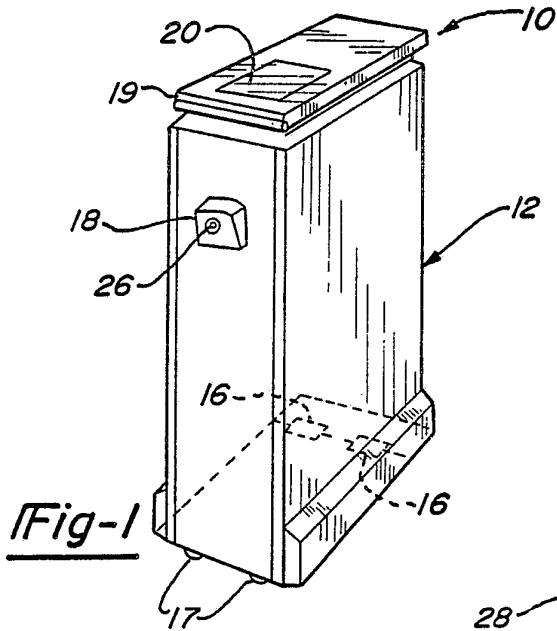

Fig-1

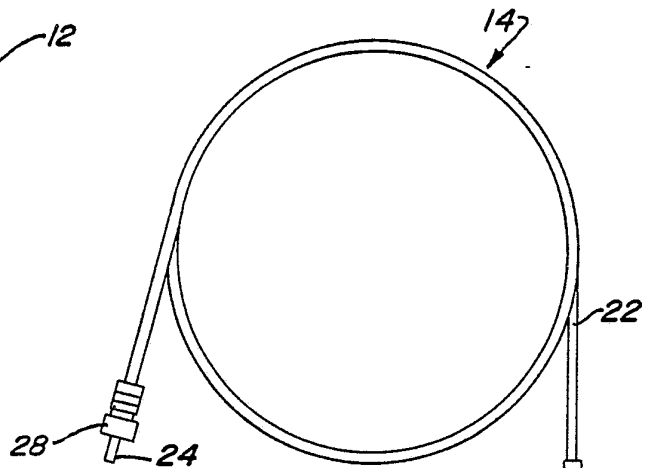

Fig-2

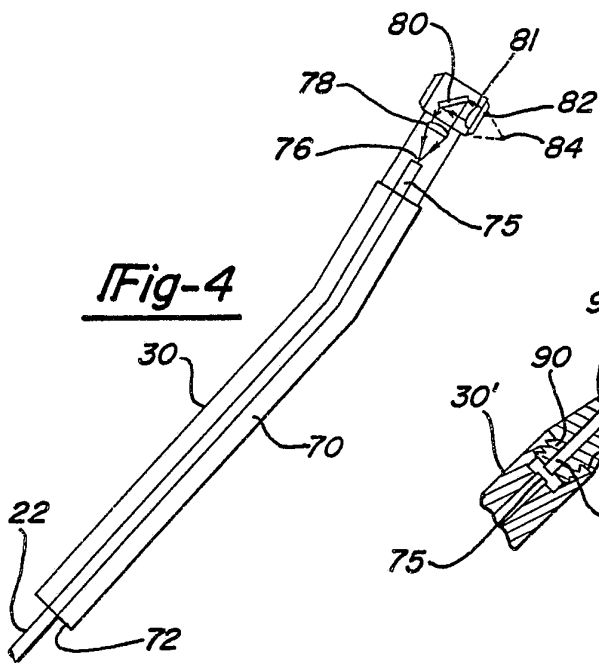

Fig-4

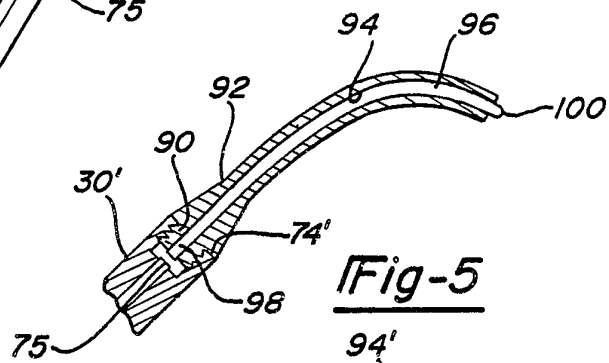

Fig-5

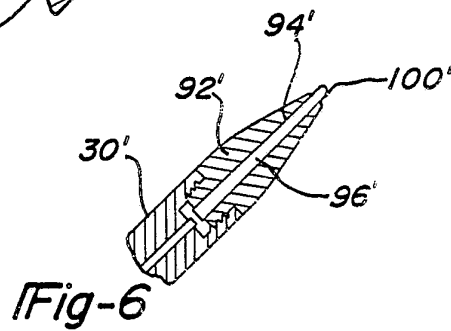

Fig-6

1/2

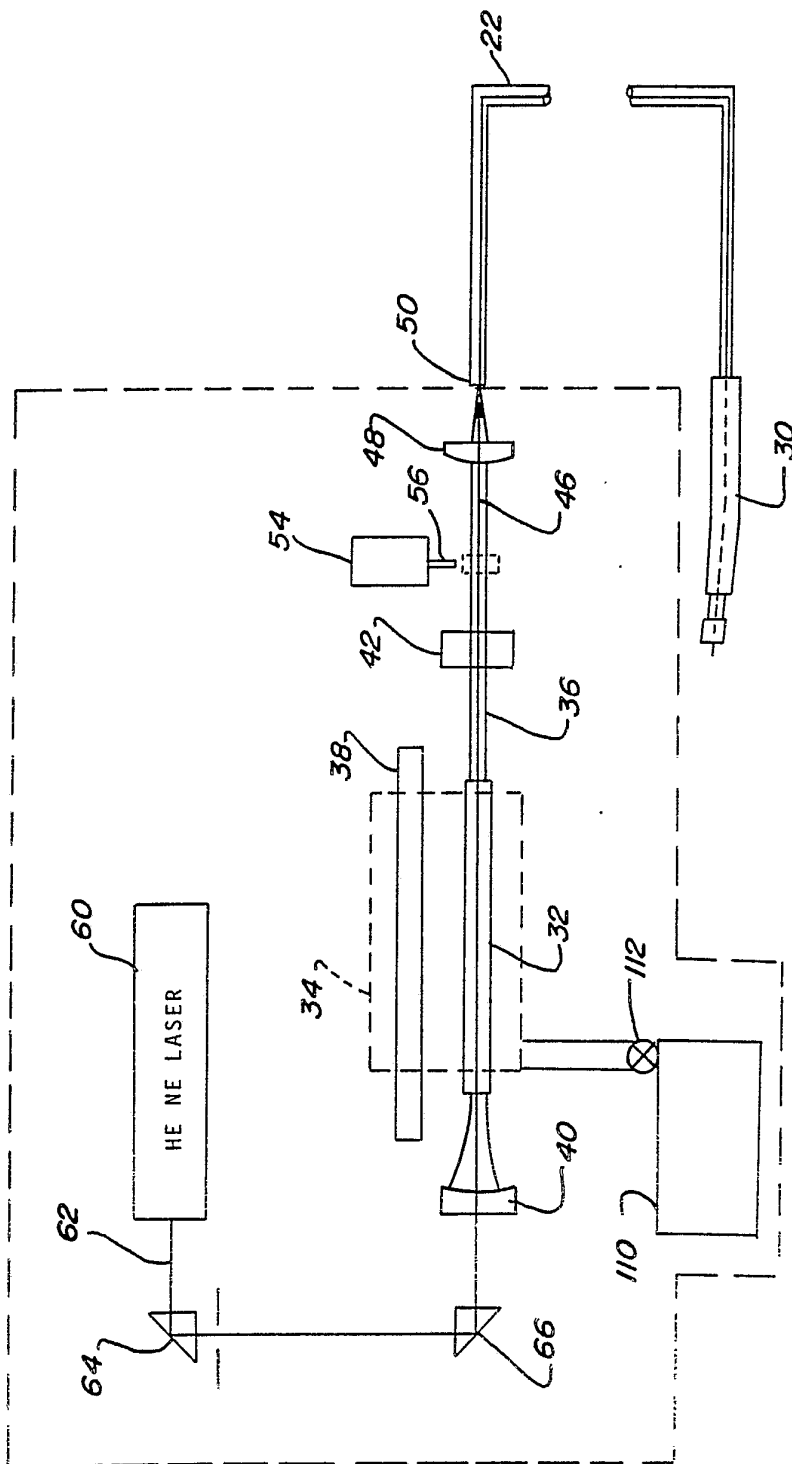
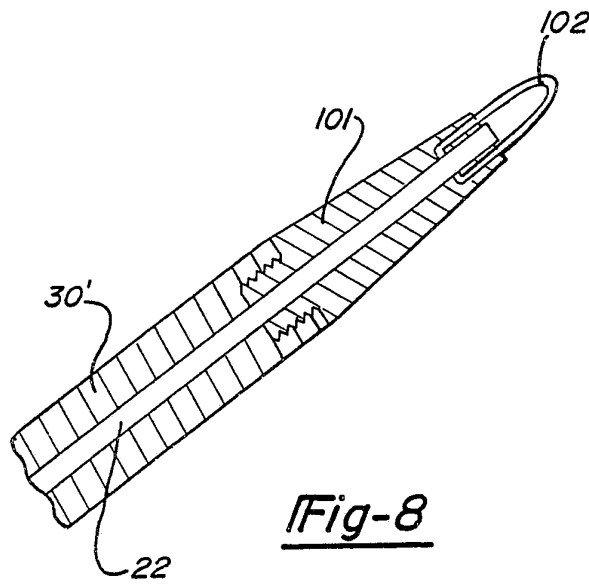
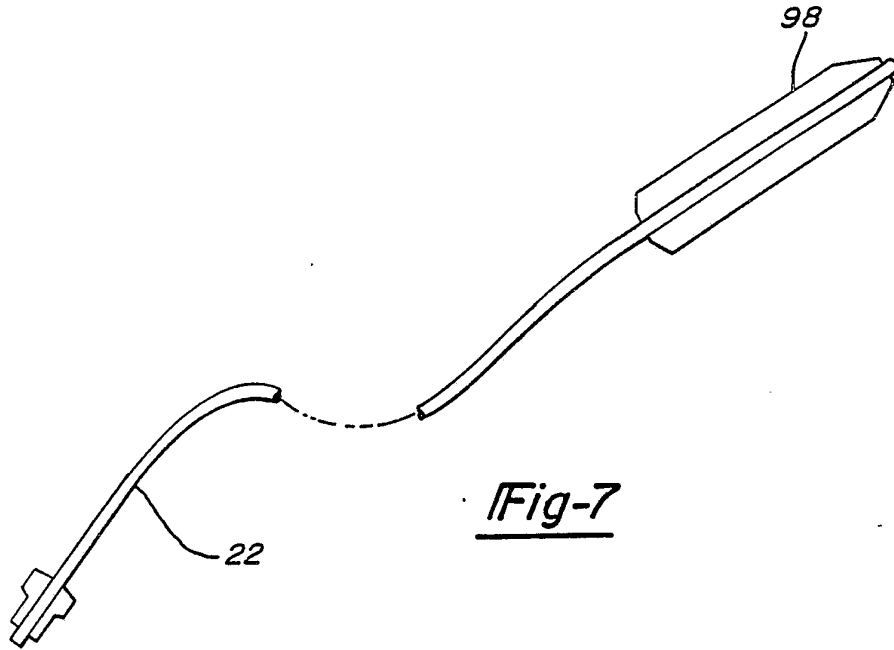

Fig-3

3/4



4/4

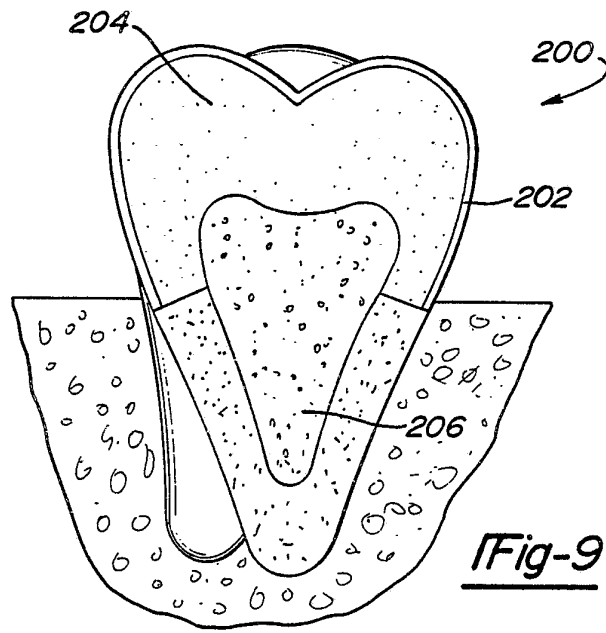

Fig-9

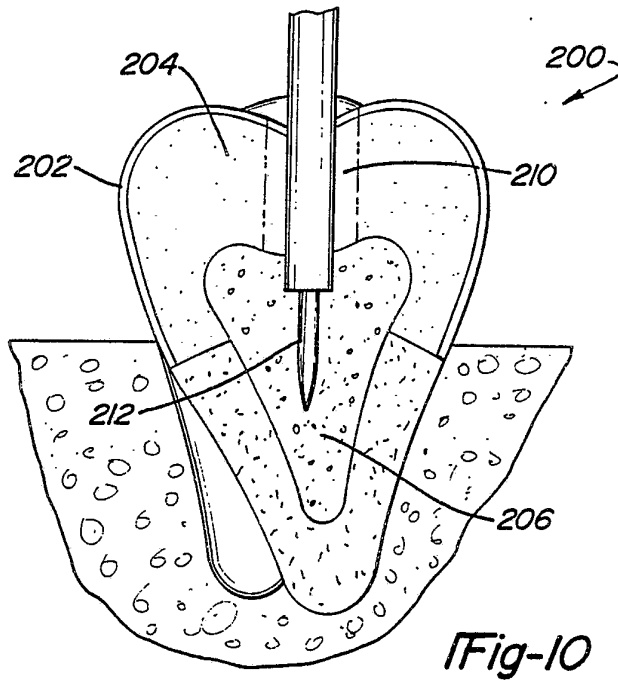

Fig-10



# INTERNATIONAL SEARCH REPORT

International Application No. **PCT/US89/03825**

<b>I. CLASSIFICATION OF SUBJECT MATTER</b> (if several classification symbols apply, indicate all) <sup>6</sup>		
According to International Patent Classification (IPC) or to both National Classification and IPC		
IPC(4): A61C 5/00		
US.CL : 433/215		
<b>II. FIELDS SEARCHED</b>		
Minimum Documentation Searched <sup>7</sup>		
Classification System	Classification Symbols	
U.S.	433/215, 29; 128/303.1, 397, 398	
Documentation Searched other than Minimum Documentation to the Extent that such Documents are Included in the Fields Searched <sup>8</sup>		
<b>III. DOCUMENTS CONSIDERED TO BE RELEVANT <sup>9</sup></b>		
Category *	Citation of Document, <sup>11</sup> with indication, where appropriate, of the relevant passages <sup>12</sup>	Relevant to Claim No. <sup>13</sup>
Y	US,A, 4,273,535 (YAMAMOTO ET AL), 16 JUNE 1981. See column 2, line 25 to column 4, line 25.	1-14
Y,P	US,A, 4,826,431 (FUJIMURA ET AL), 02 MAY 1989. See abstract; column 5, line 59 to column 6, line 11.	1-14
Y	US,A, 4,316,467, (MUCKERHEIDE) 23 FEBRUARY 1982. See column 4, lines 14-16, 51-53.	1-14
Y,P	US,A, 4,852,567 (SINOFSKY), 01 AUGUST 1989. See column 2, lines 65-68.	3,4
Y	US,A, 4,608,980 (AIHARA), 02 SEPTEMBER 1986. See document.	7-10
Y	US,A, 4,538,609 (TAKENAKA), 03 SEPTEMBER 1985. See column 2, line 13 to column 3, line 34.	11
<p>* Special categories of cited documents: <sup>10</sup></p> <p>"A" document defining the general state of the art which is not considered to be of particular relevance</p> <p>"E" earlier document but published on or after the international filing date</p> <p>"L" document which may throw doubts on priority claim(s) or which is cited to establish the publication date of another citation or other special reason (as specified)</p> <p>"O" document referring to an oral disclosure, use, exhibition or other means</p> <p>"P" document published prior to the international filing date but later than the priority date claimed</p> <p>"T" later document published after the international filing date or priority date and not in conflict with the application but cited to understand the principle or theory underlying the invention</p> <p>"X" document of particular relevance; the claimed invention cannot be considered novel or cannot be considered to involve an inventive step</p> <p>"Y" document of particular relevance; the claimed invention cannot be considered to involve an inventive step when the document is combined with one or more other such documents, such combination being obvious to a person skilled in the art.</p> <p>"&amp;" document member of the same patent family</p>		
<b>IV. CERTIFICATION</b>		
Date of the Actual Completion of the International Search		Date of Mailing of this International Search Report
02 November 1989		<b>27 NOV 1989</b>
International Searching Authority		Signature of Authorized Officer
		<i>Cary E. Stone</i> Cary E. Stone

III. DOCUMENTS CONSIDERED TO BE RELEVANT (CONTINUED FROM THE SECOND SHEET)		
Category*	Citation of Document, with indication, where appropriate, of the relevant passages	Relevant to Claim No
Y,P	US,A, 4,818,230 (MEYERS ET AL), 04 APRIL 1989. See entire document.	23-26,28-32
Y P	US,A, 4,784,135 (BLUM ET AL), 15 NOVEMBER 1988. See column 2, lines 11-15, 27-29, column 3, lines 2-17; column 6, lines 27-39.	23-26, 28-32
A	US,A, 4,672,969 (DEW), 16 JUNE 1987. See entire document.	1-32
A	US,A, 4,273,109 (ENDERBY), 16 JUNE 1981. See entire document.	1-32
A	US,A, 4,503,853 (OTA ET AL), 12 MARCH 1985. See entire document.	1-32