

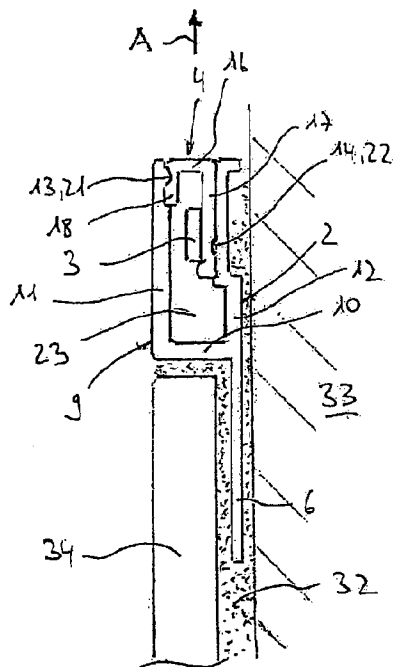

(22) Date de dépôt/Filing Date: 2014/01/09
(41) Mise à la disp. pub./Open to Public Insp.: 2014/07/11
(45) Date de délivrance/Issue Date: 2021/02/16
(30) Priorité/Priority: 2013/01/11 (DE20 2013 100 144.9)

(51) Cl.Int./Int.Cl. *E04F 19/06* (2006.01),
E04F 19/02 (2006.01)
(72) Inventeur/Inventor:
SCHLUTER, WERNER, DE
(73) Propriétaire/Owner:
SCHLUTER SYSTEMS (CANADA) INC., CA
(74) Agent: SMART & BIGGAR IP AGENCY CO.

(54) Titre : SYSTEME DE PROFIL
(54) Title: PROFILE SYSTEM



(57) **Abrégé/Abstract:**

A profile system (1) for finishing or defining a tile covering (34) provided over a base (33) comprising - at least one elongate profile (2) that has a fastening arm (6) and a profile section (9) adjoining the latter which has a defining arm (10) extending transversely, in particular at right angles, to the fastening arm (6) and two side arms (11, 12) extending transversely, in particular at right angles to the free ends of the defining arm (10) and arranged lying opposite one another, - at least one illuminant (3) that in the correct state is disposed in the receiving space defined by the substantially U-shaped profile section (9), - and at least one elongate diffusion disc cover (4, 5) that can be secured to the profile (2).

Abstract

A profile system (1) for finishing or defining a tile covering (34) provided over a base (33) comprising

- at least one elongate profile (2) that has a fastening arm (6) and a profile section (9) adjoining the latter which has a defining arm (10) extending transversely, in particular at right angles, to the fastening arm (6) and two side arms (11, 12) extending transversely, in particular at right angles to the free ends of the defining arm (10) and arranged lying opposite one another,
- at least one illuminant (3) that in the correct state is disposed in the receiving space defined by the substantially U-shaped profile section (9), and
- at least one elongate diffusion disc cover (4, 5) that can be secured to the profile (2).

(Figure 2)

DESCRIPTION**Profile System**

The present invention relates to a profile system for finishing or defining a slab covering provided over a base, for example in the form of tiles or the like.

Profiles for finishing or defining a tile covering provided over a base, such as for example on a wall or on a floor, are known in a wide variety of different configurations in the prior art. They serve to protect the exposed edges of the tiles on the edge of a tile covering. Moreover, they are also often used as decorative strips. One example of this type of profile is described, for example, in DE-U-297 09 378.

Proceeding from this prior art it is an object of the present invention to extend the area of application of profiles of the type specified at the start.

In order to achieve this object, the present invention provides a profile system for finishing or defining a tile covering provided over a base, comprising at least one elongate profile that has a fastening arm and a profile section adjoining the latter which has a defining arm extending transversely, in particular at right angles, to the fastening arm, and two side arms extending transversely, in particular at right angles, to the free ends of the defining arm and arranged lying opposite one another, at least one illuminant, that in the correct

state is disposed in the receiving space defined by the profile section, and at least one elongate diffusion disc cover that can be secured to the profile.

In the correctly arranged state the elongate profile is fastened to the base by the fastening arm. There are arranged over the top of the fastening arm tiles of the tile covering which are defined and protected by an outside of the profile section which is preferably substantially U-shaped. In addition to this conventional protective function the profile system according to the invention provides illumination which can be used, for example, as cove lighting for a ceiling, as plinth lighting for a base or the like. The illuminant is held in the profile section and is freely accessible after removing the diffusion disc cover so that, for example, repair work can be carried out without any problem. Consequently, the profile system according to the invention combines the functions of defining and protecting tile coverings with the function of providing visually attractive illumination.

According to one configuration of the present invention the profile is an extruded profile with a consistent cross-section. It is an advantage of extruded profiles that they are easy and inexpensive to produce.

Preferably, the profile is produced from aluminium or stainless steel. On the one hand, aluminium and stainless steel give the profile a visually attractive appearance. On the other hand, these materials are resistant to cor-

rosion and accordingly are well suited for use in wet rooms, such as for example in bathrooms, in outdoor areas or the like.

According to one configuration of the present invention the fastening arm has through-holes arranged along its length, spaced apart from one another. An adhesive, such as for example a tile adhesive, used to secure the fastening arm to a base can pass through these through-holes, by means of which anchoring, and so securing of the fastening arm to the base is brought about.

According to an alternative configuration a fleece or a fabric is fastened to the back of the fastening arm. This fleece or fabric then serves as an adhesive base for the adhesive which is used to secure the fastening arm to a base.

Preferably, fastening means which co-operate with one another are provided on the diffusion disc cover and on the profile. Advantageously, the fastening means are made integrally with the profile and the diffusion disc cover, by means of which an inexpensive structure with a small number of individual components can be produced.

According to one configuration of the present invention the fastening means define a manually releaseable snap-on connection and in particular are provided in the form of protrusions and recesses that engage with one another. In this way one can produce a very simple fastening means structure.

According to one configuration of the present invention the diffusion disc cover has a base section and two side sections projecting from the latter and arranged lying opposite one another.

The first side section is preferably made to be longer than the second side section, in the correctly arranged state the illuminant being fastened to the inside of the region of the first side section which projects over the second side section. This design is advantageous in that due to the shorter second side section the illuminant disposed on the inside of the first side section is easily accessible, by means of which the manageability of the profile system is improved.

There is preferably provided in the region of the free end of the first side section an inwardly pointing protrusion which serves as a stop for the illuminant. This stop facilitates correct positioning of the illuminant and in addition contributes to stable fastening of the illuminant.

According to a first alternative of the present invention, in the correct state the base section of the diffusion disc cover terminates flush with the free ends of the side arms of the profile. In this first alternative light emitted by the first illumination means can accordingly only pass out of the profile in one direction.

According to a second alternative the second side section of the diffusion disc cover has in the region of its free end a region receding towards the first side section which is configured such that, in the correctly arranged state, the outer surface of the projecting region of the second side section terminates substantially flush with the outer surface of the adjacently arranged side arm of the profile. In this second alternative the light can accordingly also leave the profile in a second direction, as will be explained in more detail by means of the exemplary embodiment described below.

It should be made clear at this point that a profile system according to the present invention can have both a diffusion disc cover according to the first alternative and a diffusion disc cover of the second alternative.

The illuminant is preferably elongate in form, in particular in the form of a strip or a chain with a plurality of LEDs arranged over the latter.

According to one configuration of the present invention the illuminant is designed and arranged such that, in the correctly arranged state, light is irradiated towards the base section of the diffusion disc cover.

According to one aspect of the present invention, there is provided a profile system for finishing or defining a tile covering provided over a base, the profile system comprising: at least one elongate profile that has a fastening arm and a substantially U-shaped profile section adjoining the fastening arm, the substantially U-shaped profile section having a defining arm extending transversely to the fastening arm and two side arms extending transversely to free ends of the

defining arm and arranged lying opposite one another, at least one illuminant that in an installed state is disposed in a receiving space defined by the substantially U-shaped profile section, and at least one elongate diffusion disc cover that is capable of being secured to the at least one elongate profile; wherein the at least one elongate diffusion disc cover has a base section and two side sections projecting from the base section and arranged lying opposite one another, wherein the two side sections comprise a first side section and a second side section; and the first side section is made to be longer than the second side section, wherein in the installed state the at least one illuminant is fastened to an inside of a region of the first side section which projects over the second side section.

According to another aspect of the present invention, there is provided a profile system for finishing or defining a tile covering provided over a base, the profile system comprising: at least one elongate profile that has a fastening arm and a substantially U-shaped profile section adjoining the fastening arm, the substantially U-shaped profile section having a defining arm extending transversely to the fastening arm and two side arms extending transversely to free ends of the defining arm and arranged lying opposite one another, at least one illuminant that in an installed state is disposed in a receiving space defined by the substantially U-shaped profile section, and at least one elongate diffusion disc cover that is capable of being secured to the at least one elongate profile; wherein the at least one elongate diffusion disc cover has a base section and two side sections projecting from the base section and arranged lying opposite one another, and wherein in

the installed state the at least one illuminant is fastened to an inside of a region of one of the two side sections.

Further features and advantages of the present invention become clear from the following description of an exemplary embodiment of profile system according to the invention with reference to the attached drawings. These show as follows:

- Figure 1 a perspective view which shows the individual components of a profile system according to one embodiment of the present invention;
- Figure 2 a side view which shows the profile system illustrated in Figure 1 in a first fitted state; and
- Figure 3 a side view which shows the profile system illustrated in Figure 1 in a second fitted state.

Figure 1 shows a profile system 1 according to one embodiment of the present invention that serves to finish or define a tile covering provided over a base and to provide illumination. The profile system 1 comprises as main components a profile 2, an illuminant 3 and two types of diffusion disc cover 4 and 5.

The profile 2 is an extruded profile that is preferably produced from aluminium or stainless steel, other materials basically also being able to be used, such as for example plastic or the like. The profile 2 comprises a fastening arm 6 which in this instance is provided with through-holes 7 arranged along its length, spaced apart from one another. A viscous adhesive, such as for example a tile adhesive, used to fasten the profile 2 to a base can penetrate through these through-holes 7, by means of which anchoring is achieved in a known manner. Alterna-

tively however, a fleece or fabric (not detailed) can also be fastened to the back 8 of the fastening arm 6, said fleece or fabric forming an adhesive base for an appropriate adhesive. The profile 2 further comprises a substantially U-shaped profile section 9 which is made integrally with the fastening arm 6. The U-shaped profile section 9 has a defining arm 10 extending at right angles to the fastening arm 6 and two side arms 11 and 12 extending at right angles to the free ends of the defining arm 10 and arranged lying opposite one another, the side arm 12 being arranged as an extension of the fastening arm 6. There are arranged on the insides of the side arms 11 and 12 inwardly projecting protrusions 13 and 14 which serve to releaseably hold the diffusion disc cover 4 or the diffusion disc cover 5, as will be described in more detail below. Moulded into the outside of the side arm 12 is a recess 15 which serves to hold excess adhesive when sticking the profile 2 to a base.

The diffusion disc cover 4 is produced from transparent plastic and comprises a base section 16 and two side sections 17 and 18 projecting from the latter at right angles and arranged lying opposite one another. The first side section 17 is made to be longer than the second side section 18 and on its inside in the region which projects over the second side section 18 holds the illuminant 3 which in this instance is secured by an adhesive strip 19. By virtue of the different lengths of the side sections 17 and 18 the illuminant 3 is easily accessible to a user. In the region of the free end of the first side section 17 there is an inwardly pointing protrusion 20

which serves as a stop for the illuminant 3. Each side section 17, 18 is provided on its outside with a groove-shaped recess 21, 22, in the correctly arranged state the groove-shaped recesses 21 and 22 co-operating with the elongate protrusions 13 and 14 of the profile 2 and defining a manually releaseable snap-on connection, as shown in Figure 2. Accordingly, the diffusion disc cover 4 with the illuminant 3 held on the latter can be inserted from above between the side arms 11 and 12 of the profile 2 until the snap-on connection engages. If the diffusion disc cover 4 is inserted into the profile 2 the arrangement illustrated in Figure 2 is produced in which the outside of the base section 16 of the diffusion disc cover terminates flush with the free ends of the side arms 11 and 12 of the profile 4. Accordingly, light emitted by the illuminant 3 can only leave the profile 2 in the direction of arrow A. In the correctly arranged state a duct 23 is left beneath the diffusion disc cover 4 which can be used, for example, for the laying of cables.

The diffusion disc cover 5 is also produced from transparent plastic and comprises a base section 24 and two side sections 25 and 26 projecting from the latter at right angles and arranged lying opposite one another. The first side section 25 is made to be longer than the second section 26, the illuminant 3 being fastened by an adhesive strip 19 to the inside of the region of the first side section 25 that projects over the second side section 26. By virtue of the different lengths of the side sections 25 and 26 the illuminant 3 is easily accessible to a user. In the region of the free end of the first

side section 25 there is an inwardly pointing protrusion 27 which forms a stop for the illuminant 3. The side sections 25 and 26 are respectively provided on their outside with a groove-shaped recess 28, 29 which in turn cooperate with the elongate protrusions 13 and 14 of the profile 2 such as to produce a releaseable snap-on connection. The second side section 26 of the diffusion disc cover 5 has in the region of its free end a region 30 receding towards the first side section 25 and which is designed such that, in the correctly arranged state, the outer surface of the correspondingly projecting region 31 of the second side section 26 terminates substantially flush with the outer surface of the adjacently arranged side arm 11 of the profile 2, as shown in Figure 3. Accordingly, light emitted by the illuminant 3 can leave the profile 2 in the direction of arrows A and B.

The illuminant 3 is an elongate strip with a plurality of LEDs arranged over the latter. The emission of light from the illuminant 3 is chosen such that in the correctly arranged state light is irradiated towards the base section 16, 24 of the corresponding diffusion disc cover 4, 5.

Figures 2 and 3 show the profile system 1 in the fitted state, according to Figure 2 the diffusion disc cover 4 and according to Figure 3 the diffusion disc cover 5 being held on the profile 2, by means of which different light effects are achieved. The profile 2 is respectively stuck to a base 33 using a tile adhesive 32. The hold between the profile 2 and the tile adhesive 32 is achieved by the tile adhesive 32 penetrating through the through-

holes 7, by means of which corresponding anchoring takes place. The tiles 34 which are arranged adjacent to the profile 2 cover the fastening arm 6 of the profile 2 and are adjacent to the defining arm 10 which serves to protect the tile edge.

It is an advantage of the profile system 1 that it provides both a protective effect for the edges of the adjacently laid tiles as well as illumination which can be used, for example, as cove lighting for a ceiling, as plinth lighting for a base or the like. Moreover, by choosing appropriate diffusion disc covers 4 and 5 different light effects can be achieved. Moreover, the profile system 1 can be produced inexpensively and be handled easily.

LIST OF REFERENCE NUMBERS

1	profile system	23	duct
2	profile	24	base section
3	illuminant	25	side section
4	diffusion disc cover	26	side section
5	diffusion disc cover	27	protrusion
6	fastening arm	28	groove-shaped recess
7	through-hole	29	groove-shaped recess
8	back	30	receding region
9	profile section	31	projecting region
10	defining arm	32	tile adhesive
11	side arm	33	base
12	side arm	34	tile
13	protrusion		
14	protrusion	A	arrow
15	recess	B	arrow
16	base section		
17	side section		
18	side section		
19	adhesive strip		
20	protrusion		
21	groove-shaped recess		
22	groove-shaped recess		

CLAIMS:

1. A profile system for finishing or defining a tile covering provided over a base, the profile system comprising:

at least one elongate profile that has a fastening arm and a substantially U-shaped profile section adjoining the fastening arm, the substantially U-shaped profile section having a defining arm extending transversely to the fastening arm and two side arms extending transversely to free ends of the defining arm and arranged lying opposite one another,

at least one illuminant that in an installed state is disposed in a receiving space defined by the substantially U-shaped profile section, and at least one elongate diffusion disc cover that is capable of being secured to the at least one elongate profile; wherein

the at least one elongate diffusion disc cover has a base section and two side sections projecting from the base section and arranged lying opposite one another, wherein the two side sections comprise a first side section and a second side section; and

the first side section is made to be longer than the second side section, wherein in the installed state the at least one illuminant is fastened to an inside of a region of the first side section which projects over the second side section.

2. The profile system according to Claim 1, wherein the at least one elongate profile is an extruded profile with a consistent cross-section.

3. The profile system according to Claim 1 or Claim 2,

wherein the at least one elongate profile is produced from aluminium or stainless steel.

4. The profile system according to any one of Claims 1 to 3, wherein the fastening arm has through-holes arranged along a length of the fastening arm, the through-holes spaced apart from one another.

5. The profile system according to any one of Claims 1 to 4, wherein a fleece or a fabric is fastened to a back of the fastening arm.

6. The profile system according to any one of Claims 1 to 5, wherein fastening means which co-operate with one another are provided on the at least one elongate diffusion disc cover and on the at least one elongate profile.

7. The profile system according to Claim 6, wherein the fastening means are made integrally with the at least one elongate profile and the at least one elongate diffusion disc cover.

8. The profile system according to Claim 7, wherein the fastening means define a manually releaseable snap-on connection.

9. The profile system according to Claim 8, wherein the fastening means are provided in the form of protrusions and recesses that engage with one another.

10. The profile system according to Claim 1, wherein

there is provided in a region of a free end of the first side section an inwardly pointing protrusion which serves as a stop for the at least one illuminant.

11. The profile system according to Claim 1 or Claim 10, wherein in the installed state the base section of the at least one elongate diffusion disc cover terminates flush with free ends of the two side arms of the profile.

12. The profile system according to Claim 1 or Claim 10, wherein the second side section of the at least one elongate diffusion disc cover has in a region of a free end of the second side section a receding region receding towards the first side section which is configured such that, in the installed state, an outer surface of a projecting region of the second side section terminates substantially flush with an outer surface of an adjacently arranged side arm of the profile.

13. The profile system according to any one of claims 1 to 12, wherein the at least one illuminant is elongate in form.

14. The profile system of Claim 13, wherein the at least one illuminant is in the form of a strip or a chain with a plurality of LEDs arranged over the strip or the chain.

15. The profile system according to any one of claims 1 to 14, wherein the at least one illuminant is designed and arranged such that, in the installed state, light is irradiated towards the base section of the at least one elongate diffusion disc cover.

16. The profile system according to any one of Claims 1 to 15, wherein the defining arm extends at a right angle to the fastening arm.

17. The profile system according to any one of Claims 1 to 16, wherein the two side arms extend at a right angle to the free ends of the defining arm.

18. A profile system for finishing or defining a tile covering provided over a base, the profile system comprising:

at least one elongate profile that has a fastening arm and a substantially U-shaped profile section adjoining the fastening arm, the substantially U-shaped profile section having a defining arm extending transversely to the fastening arm and two side arms extending transversely to free ends of the defining arm and arranged lying opposite one another,

at least one illuminant that in an installed state is disposed in a receiving space defined by the substantially U-shaped profile section, and at least one elongate diffusion disc cover that is capable of being secured to the at least one elongate profile; wherein

the at least one elongate diffusion disc cover has a base section and two side sections projecting from the base section and arranged lying opposite one another, and

wherein in the installed state the at least one illuminant is fastened to an inside of a region of one of the two side sections.

