

T. B. FAGAN.
 Drag-Saw.

No. 216,663.

Patented June 17, 1879.

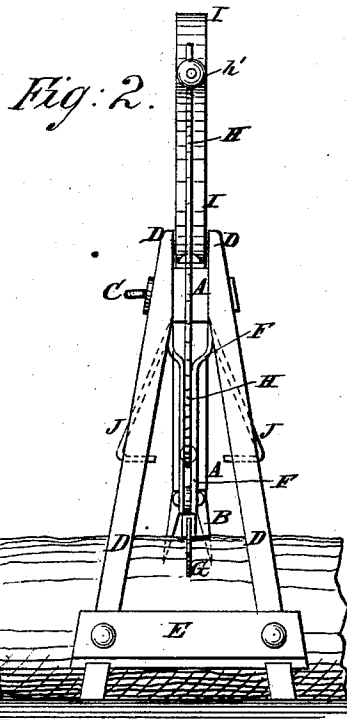
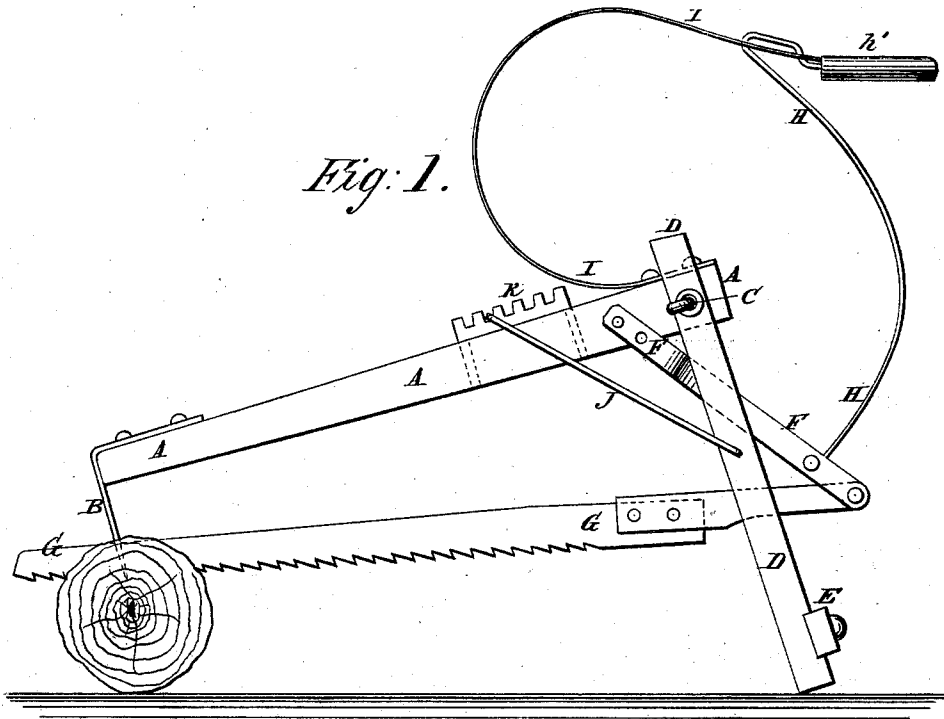

WITNESSES:

A. Schehl.
W. Sedgwick

INVENTOR:

T. B. Fagan

BY

Munn & Co.
 ATTORNEYS.

UNITED STATES PATENT OFFICE.

THOMAS B. FAGAN, OF VAN WERT, OHIO, ASSIGNOR TO HIMSELF AND
ANDREW E. BAKER, OF SAME PLACE.

IMPROVEMENT IN DRAG-SAWS.

Specification forming part of Letters Patent No. **216,663**, dated June 17, 1879; application filed
April 29, 1879.

To all whom it may concern:

Be it known that I, THOMAS B. FAGAN, of Van Wert, in the county of Van Wert and State of Ohio, have invented a new and useful Improvement in Drag-Saws, of which the following is a specification.

Figure 1 is a side view of my improved machine. Fig. 2 is a rear-end view of the same.

Similar letters of reference indicate corresponding parts.

The object of this invention is to furnish an improved machine for crosscut-sawing logs which shall be simple in construction, inexpensive in manufacture, convenient in use, effective in operation, light, strong, and durable, and easily moved from place to place.

The invention consists in the combination of the swinging bar, the curved lever, and the curved spring with the saw and the frame, and in the combination of the pivoted loop and the rack-bar with the frame that carries the saw-driving mechanism, as hereinafter fully described.

A represents a beam, to the forward end of which is attached a metallic fork, B, the prongs of which are designed to be driven into the log to be sawed, to hold the machine steady, and to serve as a guide to the saw in beginning the cut.

To the opposite sides of the rear end of the beam A are pivoted by a bolt, C, the upper ends of two bars or legs, D, which incline from each other, and are connected near their lower ends by a cross-bar, E. To the beam A, near its rear end, is pivoted the upper end of the connecting-bar F, to the lower end of which is pivoted the end of the handle of the saw G.

To the connecting-rod F, near its lower end, is pivoted the lower end of the curved lever H, the upper end of which is bent to the rearward, and has a handle, *h'*, attached to or formed upon it.

To the upper part of the curved lever H, or to the hand-piece *h'*, is attached the upper end of the curved spring I, the lower end of which is attached to the upper side of the rear end of the beam A.

With this construction, when the handle end of the lever H is forced downward the saw G will be forced forward to make a cut, the said saw being drawn back as soon as the said downward pressure is withdrawn by the elasticity of the spring I.

To the middle part of the bars or legs D are pivoted the ends of a loop, J, which passes over the beam A, and its bend engages with the teeth of the rack-bar K, formed upon or attached to the upper part of the beam A.

With this construction the loop J and rack-bar K allow the supporting bars or legs D to be adjusted at any desired inclination, so that the height of the rear end of the machine may be regulated according to the height of the log to be operated upon, and according to the height of the operator.

Having thus described my invention, I claim as new and desire to secure by Letters Patent—

1. The frame consisting of the inclined beam A, and the pivoted legs D, the swinging bar F, the curved lever H, provided with the handle *h'*, and the curved spring I, in combination with the saw G, substantially as herein shown and described.

2. The combination of the pivoted loop J and the rack-bar K with the frame A D E, that carries the saw-driving mechanism, substantially as herein shown and described.

THOMAS B. FAGAN.

Witnesses:

W. H. MOZIER,
A. W. FRITZ.