

(No Model.)

D. E. J. WELLHOENER.  
BOX FASTENER.

No. 524,876.

Patented Aug. 21, 1894.

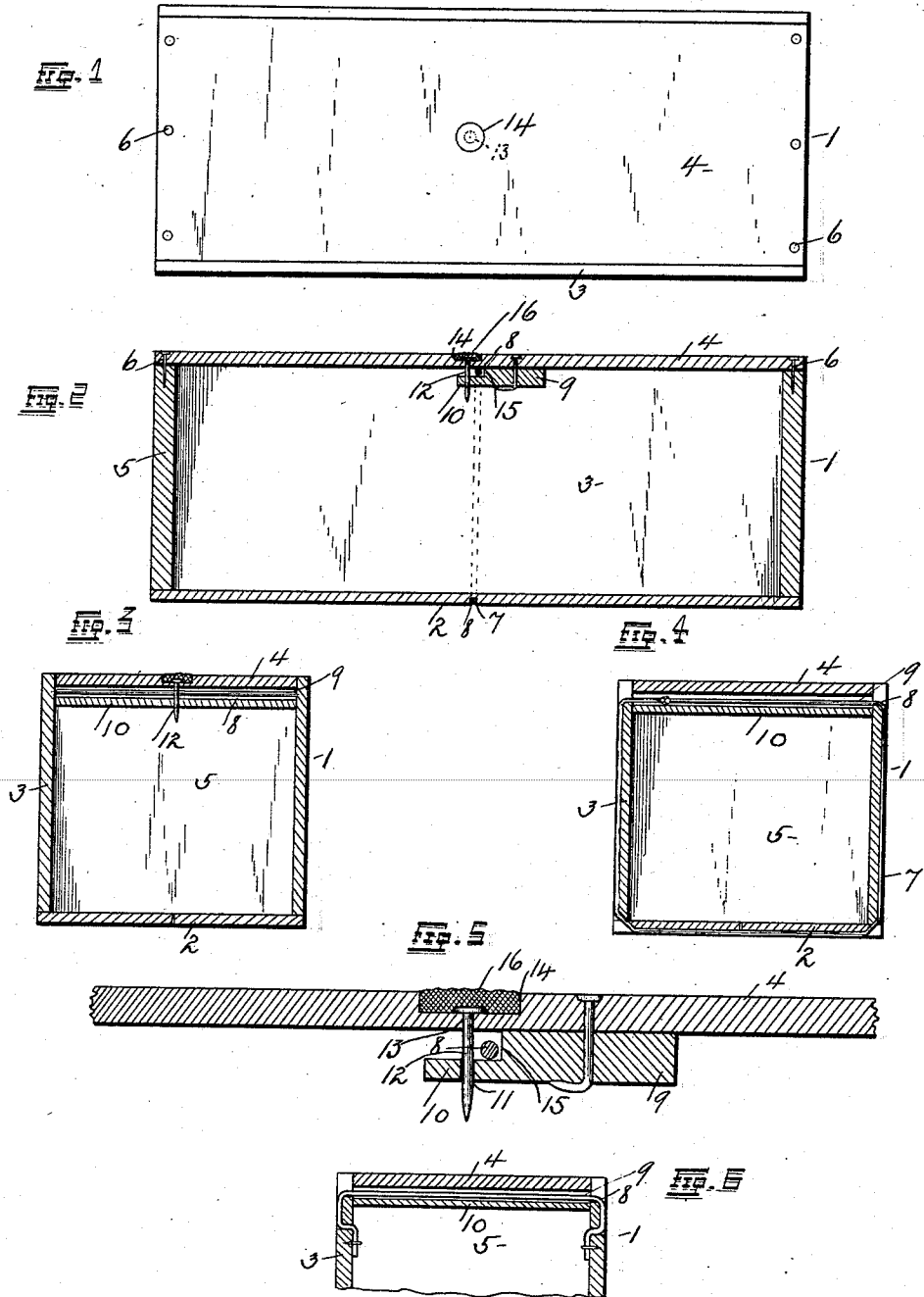

Witnesses  
*A. H. Chapman*  
*J. Easton*

Inventor,  
Daniel E. J. Wellhoener,  
By *Clara Robinson* Attorneys

# UNITED STATES PATENT OFFICE.

DANIEL E. J. WELLHOENER, OF ST. LOUIS, MISSOURI.

## BOX-FASTENER.

SPECIFICATION forming part of Letters Patent No. 524,876, dated August 21, 1894

Application filed March 9, 1894. Serial No. 503,074. (No model.)

*To all whom it may concern:*

Be it known that I, DANIEL E. J. WELLHOENER, a citizen of the United States, and a resident of St. Louis, State of Missouri, have invented certain new and useful Improvements in Box-Fasteners, of which the following is a full, clear, and exact description, reference being had to the accompanying drawings, forming a part hereof.

My invention relates to improvements in a "box fastener," and consists in the novel arrangement, construction and combination of parts as will be more fully hereinafter described and set forth in the claim.

The object of my improvement is to construct a combined lock and fastener for the protection of shipping cases and boxes, whereby their safe transit can be assured and any maltreatment of the contents discovered.

Many lines of business use some means for protecting their shipping trade, as few persons care to take the risks of destroying a fastened box to obtain its contents, owing to the liability of detection. It is necessary in an invention of this kind, to include means for preventing any tampering with the bottom and sides of the box or case, as well as a fastener for the lid after it has been placed in position.

It is believed that in the development of my ideas, I have only included such features as are necessary to the simple, yet complete construction of a fastener, and its extreme simplicity serves to demonstrate its usefulness and effectiveness in this particular line of improvement, as it includes all the requirements for safety.

In the drawings:—Figure 1 is a top plan view of a box with my improvement applied thereto. Fig. 2 is a vertical longitudinal sectional view showing all the parts in detail. Fig. 3 is a vertical transverse sectional view showing the position of the locking pin. Fig. 4 is a similar view showing the position of the binding wire. Fig. 5 is an enlarged sectional view of a portion of the lid showing all parts in their relative position. Fig. 6 is an enlarged sectional view of a portion of the sides and top of the box to show the binder secured in a different manner.

Before entering into a description of my

invention, I desire to state that this improvement is applicable to any kind of a shipping or packing case which in its construction is rigid enough to hold the parts. The construction of the box or case depends entirely upon the use to which it is to be put, and such construction will not therefore limit the invention to other applications. The box shown in the accompanying drawings is merely used to illustrate the ideas of my invention.

In small boxes for the shipping of medicines and analogous articles, I am enabled to piece the bottom, thus making a decided saving in the manufacture. The binding wire used makes such a bottom fully as desirable for general purposes, as a one-piece bottom.

1 indicates a box of the ordinary pattern and consisting of a bottom 2, sides 3 and lid 4 besides the ends 5 which are not affected by the application of the improvement. In this instance the lid 4 is set in flush with the upper edges of the sides 3, nails 6 being used to secure the lid to the ends 5. The bottom 2 is simply secured to the sides and ends in the usual manner. A groove 7 is cut transversely through the bottom 2 and sides 3 as shown in Fig. 4, the groove being very shallow throughout the main portion of its length except at the lower corners where the same is deeper to secure the binder wire 8 against slipping. In this connection it is perhaps best to state that the binder need not necessarily be a wire, as cables, band metal, ropes, &c., could be used to serve the same purpose.

Fig. 4 shows very plainly the position of the binder 8 in relation to the top of the box. The groove 7 extends entirely through the upper portions of the sides 3 to allow the binder to pass under and in close proximity to the lid 4.

Secured transversely upon the under side of the lid 4 is a strip 9, provided with a shoulder 10 upon one of its lower edges as particularly shown in Fig. 5. This shoulder is provided with a small opening 11, of sufficient size to admit a nail 12 which serves as the sealing pin. Said opening 11 is in alignment with an opening 13 of similar size in the lid proper. Said opening 13 is located in a countersunk portion 14, the function of which will now be described. The strip 9 is

preferably held to the lid by clinched nails but it is apparent that other means could be used without affecting the idea of my invention.

5 The binder is put around the box, the contents placed therein and the lid placed in position. It is necessary in performing the latter operation, to slide the lid along into place so that the binder 8 will be between the shoulder 10 and the under surface of the lid.

10 The pin 12 is dropped through the openings 13 in the lid 4 and 11 in the shoulder 10, thus confining the binder 8 between the pin 12 and the edge 15 of the strip 9 above the shoulder 10. The countersunk portion 14 is then filled with some kind of sealing material 16, thus entirely hiding the head of the pin 12. The seal of the establishment using the box can be imprinted in the material 16 and the box is ready for shipment.

20 It is easy to see how simple yet effective this invention is in its construction and application. The lid 4 is held by a few nails 6 inserted in the ends 5 and any tampering with the same breaks the seal, thus showing that an attempt to open the box or case has been made.

25 To remove the lid of the box, the nails 6 are withdrawn, the seal broken, the pin 12 removed and the lid slid back to enable its lifting away from the binder 8.

30 The above can be done intelligently by any one acquainted with the seal but if an ignorant person attempts to open the box for the

purpose of purloining its contents, he is sure to mutilate the seal in such a way as will render detection an easy matter.

The scope of my invention does not limit the use of a single binder nor the location of the same transversely around the box or case as other adaptations are possible.

It is believed that I have substantiated my statements as to its simplicity and effectiveness and that the description and drawings will enable a clear understanding of the invention in all its details.

In Fig. 6 I have shown how the binder could be placed simply across the top of the box, under the lid, in case any one might object to running the same around all sides of the box.

Having fully described my invention, what I claim is—

55 An improved box fastener having a binder encompassing the bottom and sides of the box, said binder inlaid flush with the outer surface of the box except at the corners where it has a deeper seat, said binder passing under the lid and adapted to be held against longitudinal movement by a pin inserted through the lid and a strip upon the under side of said lid, said pin entering a shoulder upon said strip, substantially as set forth.

60 In testimony whereof I affix my signature in the presence of two witnesses.

DANIEL E. J. WELLHOENER.

Witnesses:

HERBERT S. ROBINSON,  
ALFRED A. EICKS.