

May 20, 1924.

1,494,437

K. R. MANVILLE

OIL COOLING DEVICE FOR INTERNAL COMBUSTION ENGINES.

Filed May 10, 1923

Fig. 1.

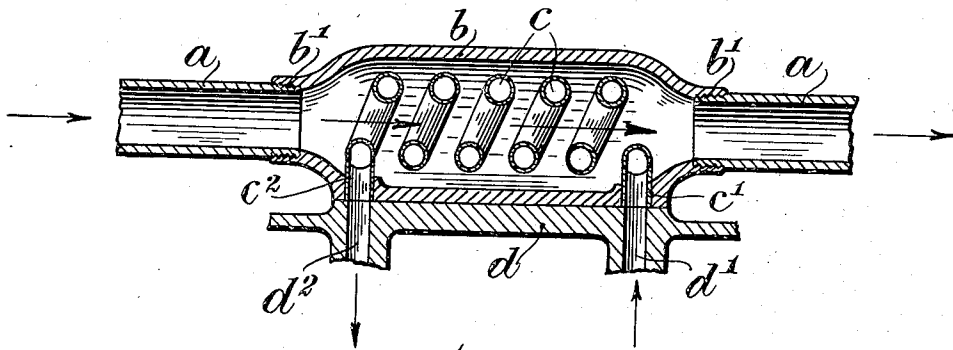
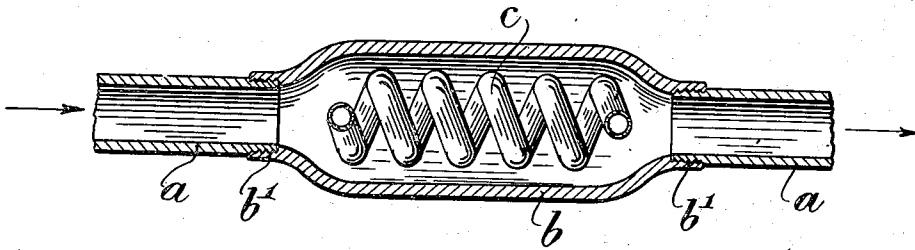

Fig. 2.

Keith R. Manville *Inventor*

By his Attorneys

Redding, Greeley, O'Shea & Campbell

UNITED STATES PATENT OFFICE.

KEITH R. MANVILLE, OF BROOKLYN, NEW YORK, ASSIGNOR TO INTERNATIONAL MOTOR COMPANY, OF NEW YORK, N. Y., A CORPORATION OF DELAWARE.

OIL-COOLING DEVICE FOR INTERNAL-COMBUSTION ENGINES.

Application filed May 10, 1923. Serial No. 637,943.

To all whom it may concern:

Be it known that I, KEITH R. MANVILLE, a citizen of the United States, residing in the borough of Brooklyn, of the city of New York, in the State of New York, have invented certain new and useful Improvements in Oil-Cooling Devices for Internal-Combustion Engines, of which the following is a specification, reference being had to the accompanying drawings, forming a part hereof.

In internal combustion engine practice it is desirable to keep the oil at as near the temperature of the cylinder wall as possible, both in summer and in winter, this condition being especially desirable in summer when the oil has a tendency to reach a temperature above that at which it is most effective in lubricating. It has been proposed heretofore to accomplish this result to some degree by an interchange of heat between the oil and cooling water but no simple device, well adapted in automotive practice to satisfy manufacturing requirements and the requirements of use, has ever been devised. In accordance with the present invention it is proposed to secure an efficient and effective interchange of heat between the lubricating oil and the cooling water of an internal combustion engine by a simple, inexpensive and unitary device which may be introduced in the circulatory system of both the water and oil without disturbing the conventional construction of any of the parts of the engine. By means of this device the oil is maintained at about the same temperature as that of the cooling water so that the temperature of the lubricating oil when thrown onto the cylinder walls is not so different from that of the cylinder walls whose temperature is influenced by the water in the jackets.

In accordance with the invention the water from the radiator is led through a casing in which is disposed a coil through which the oil passes in its circulatory system. The casing is preferably formed as an integral aluminum casting with the ends of the coil of copper pipe or the like cast directly in its walls thereby eliminating impractical joints and structural difficulties incidental thereto.

The invention will be described in connection with the accompanying drawings

which illustrate the preferred embodiment thereof. In the drawings:

Figure 1 is a view in longitudinal central section through an aluminum casing having a coil for the oil disposed centrally thereof.

Figure 2 is a similar view taken at right angles to the section of Figure 1 and indicating suitable connections for the oil pipe.

The circulatory pipe *a* for the cooling water which may be considered as extending from the radiator to the jacket of the motor is broken to admit the introduction of a tubular casing *b* of enlarged diameter which may be formed at its opposite ends with threads *b'* for convenient connection with the piping *a*, the free flow of water being wholly unimpeded by the introduction of the casing *b*. Within the casing is disposed a coil of pipe *c*, preferably copper or other efficient heat radiating metal, the coils thereof being preferably arranged co-axially with respect to the piping *a* and to the casing *b* as indicated by the arrows in Figure 2. However, the coils *c* are mounted in spaced relationship to the wall of the casing *b* and are preferably spaced from one another so that the water may flow freely around the coils and come into contact with the entire exposed superficial surface thereof. In accordance with the invention it is proposed, in the preferred embodiment, to case the ends *c'*, *c''*, of the coil *c* directly in the wall of the casing *b* thereby forming a simple, inexpensive, water-tight connection and eliminating a substantial item of expense in manufacture and lessening the danger of leakage as might be expected were conventional joints employed. The inlet end *c'* of the coil and the outlet end *c''* are preferably flush with the external surface of the casing *b* to facilitate the attachment of the manifold *d* having channels *d'*, *d''*, registering, respectively, with the ends *c'*, *c''*, for the inflow and outflow of lubricating oil, the passages *d'*, *d''*, being connected in the regular circulatory system. It is evident, however, that the ends *c'*, *c''*, of the coil might extend outside of the casing *b* and be threaded for connection of other pipes, as through union nuts. The casing *b* in the interest of lightness and cheapness in manufacture is preferably cast of aluminum, the coil *c* being placed in the mold with its ends *c'*, *c''*,

in proper position before the aluminum is poured. The ends c' , c^2 , will constitute an adequate support for the coil c and maintain it in desired relation to the flowing

5 water and to the walls of the casing.
 From the description given it will be evident that provision has been made for effecting the desired interchange of heat between the water and oil in the conventional
 10 circulatory systems of an internal combustion engine with the minimum expense, greatest accessibility and most efficient and durable devices.

Changes in details of construction may be made without departing from the spirit of the invention.

What I claim is:

1. An oil cooling device for internal combustion engines comprising a longitudinal pipe section connected in the piping of the
 20 water circulatory system and disposed co-axially therewith and a coil of pipe mounted

within the said section co-axially therewith and having its ends connected through the side walls of the said section in the circulatory oil system. 25

2. Oil cooling devices comprising a cast metal pipe section connected longitudinally in the circulatory piping of the water system and coaxially therewith and a coil of
 30 pipe disposed therein and having its ends cast in the side walls thereof and connected in the oil circulatory system.

3. As an article of manufacture a casing of cast aluminum adapted for connection
 35 in the water circulatory system of an internal combustion engine and having disposed therein a coil of copper pipe the ends of which are cast in the walls of the casing and connected in the oil circulatory
 40 system.

This specification signed this 8th day of May, A. D. 1923.

KEITH R. MANVILLE.