



(51) International Patent Classification:

C12N 9/24 (2006.01) A61P 1/16 (2006.01)
A61K 38/47 (2006.01)

(21) International Application Number:

PCT/GB2020/050251

(22) International Filing Date:

04 February 2020 (04.02.2020)

(25) Filing Language:

English

(26) Publication Language:

English

(30) Priority Data:

1901512.2 04 February 2019 (04.02.2019) GB
1917910.0 06 December 2019 (06.12.2019) GB

(71) Applicant: **FREELINE THERAPEUTICS LIMITED**

[GB/GB]; Stevenage Bioscience Catalyst, Gunnels Wood Road, Stevenage Hertfordshire SG1 2FX (GB).

(72) Inventors: **NATHWANI, Amit**; UCL Business LTD,

The Network Building, 97 Tottenham Court Road, London Greater London W1T 4TP (GB). **MCINTOSH, Jen-**

ny; UCL Business LTD, The Network Building, 97 Tottenham Court Road, London Greater London W1T 4TP (GB). **CORBAU, Romuald**; Freeline Therapeutics Limited, Stevenage Bioscience Catalyst, Gunnels Wood Road, Stevenage Hertfordshire SG1 2FX (GB). **KIA, Azadeh**; Freeline Therapeutics Limited, Stevenage Bioscience Catalyst, Gunnels Wood Road, Stevenage Hertfordshire SG1 2FX (GB). **MIRANDA, Carlos**; Freeline Therapeutics Limited, Stevenage Bioscience Catalyst, Gunnels Wood Road, Stevenage Hertfordshire SG1 2FX (GB).

(74) Agent: **JA KEMP LLP**; 14 South Square, Gray's Inn, London Greater London WC1R 5JJ (GB).

(81) Designated States (unless otherwise indicated, for every

kind of national protection available): AE, AG, AL, AM, AO, AT, AU, AZ, BA, BB, BG, BH, BN, BR, BW, BY, BZ, CA, CH, CL, CN, CO, CR, CU, CZ, DE, DJ, DK, DM, DO, DZ, EC, EE, EG, ES, FI, GB, GD, GE, GH, GM, GT, HN, HR, HU, ID, IL, IN, IR, IS, JO, JP, KE, KG, KH, KN, KP, KR, KW, KZ, LA, LC, LK, LR, LS, LU, LY, MA, MD, ME, MG, MK, MN, MW, MX, MY, MZ, NA, NG, NI, NO, NZ, OM, PA, PE, PG, PH, PL, PT, QA, RO, RS, RU, RW, SA,

(54) Title: POLYNUCLEOTIDES

FIGURE 1

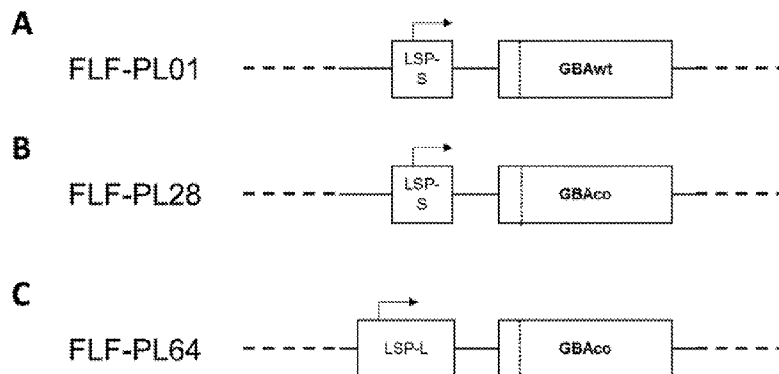

(57) Abstract: The present invention relates to polynucleotides comprising a GBA nucleotide sequence that encodes a GCase protein or fragment thereof and wherein a portion of the coding sequence is not wild type. The present invention further relates to viral particles comprising a recombinant genome comprising the polynucleotide of the invention, compositions comprising the polynucleotides or viral particles, and methods and uses of the polynucleotides, viral particles or compositions.



SC, SD, SE, SG, SK, SL, ST, SV, SY, TH, TJ, TM, TN, TR,
TT, TZ, UA, UG, US, UZ, VC, VN, WS, ZA, ZM, ZW.

- (84) Designated States** (*unless otherwise indicated, for every kind of regional protection available*): ARIPO (BW, GH, GM, KE, LR, LS, MW, MZ, NA, RW, SD, SL, ST, SZ, TZ, UG, ZM, ZW), Eurasian (AM, AZ, BY, KG, KZ, RU, TJ, TM), European (AL, AT, BE, BG, CH, CY, CZ, DE, DK, EE, ES, FI, FR, GB, GR, HR, HU, IE, IS, IT, LT, LU, LV, MC, MK, MT, NL, NO, PL, PT, RO, RS, SE, SI, SK, SM, TR), OAPI (BF, BJ, CF, CG, CI, CM, GA, GN, GQ, GW, KM, ML, MR, NE, SN, TD, TG).

Published:

- *with international search report (Art. 21(3))*
- *before the expiration of the time limit for amending the claims and to be republished in the event of receipt of amendments (Rule 48.2(h))*
- *with sequence listing part of description (Rule 5.2(a))*

POLYNUCLEOTIDES

Field of the Invention

5 The present invention relates to polynucleotides comprising a GBA nucleotide sequence encoding β -Glucocerebrosidase (GCCase), viral particles comprising the polynucleotides and treatments utilising the polynucleotides.

Background to the Invention

10

Gaucher disease (GD) is an autosomal recessive lipid storage disease characterised by the deposition of glucocerebroside in cells of the macrophage-monocyte system. GD is caused by mutations in the housekeeping GBA gene that impairs activity and/or production of the enzyme β -Glucocerebrosidase (GCCase).

15

There are three major types of GD which are characterised by the specific mutations which have been identified, and each type can display differing clinical symptoms. Type 1 GD has little or no involvement with the central nervous system but is mainly characterised by visceral manifestations such as enlarged spleen and liver, low blood cell counts, bleeding
20 problems and bone disease. For the past 20 years, enzyme replacement therapy has emerged as the standard of care for type 1 GD. In addition to its high cost (~\$200,000 or ~£150,000/patient/year), enzyme replacement therapy treatment in GD generally requires one or more injections every other week for life. This leads to a high proportion of GD patients displaying high levels of treatment burden.

25

Accordingly, there is a need to provide an effective therapy vector for the treatment of GD, *i.e.* one that allows for a high level of GCCase expression.

The present application relates to a gene therapy approach for treating GD, involving
30 administering a viral particle comprising a GBA polynucleotide encoding GCCase. The polynucleotides and viral particles described herein can provide higher GCCase expression

compared to polynucleotides comprising a wild type GCCase encoding polynucleotides. Such a gene therapy approach would avoid the need for frequent and lifelong intravenous injections of GCCase.

5 Summary of the Invention

The present application demonstrates that specific modifications to a GBA nucleotide sequence encoding for GCCase can help to improve the expression level and the activity of the expressed GCCase polypeptide *in vitro* and/or *in vivo*. For example, the present
10 application demonstrates that using a codon-optimised GBA nucleotide sequence can improve the expression and/or activity of the encoded GCCase protein. Such modified (*i.e.* non wild-type) and/or codon-optimised GBA nucleotide sequences may be further modified to provide further improvements in the expression and/or activity of the encoded
15 GCCase protein. Further modifications may include providing further modifications in the GBA nucleotide sequence such as the removal of CpG motifs, and/or the use of particular gene regulatory elements comprising specific promoter and/or enhancer sequences. It is believed that such improvements to a GBA nucleotide sequence can improve the efficacy of such a nucleotide in the treatment of GD.

20 These modifications provide a GBA nucleotide sequence which is expressed highly, for example in the liver, and which encodes a GCCase polypeptide or fragment thereof. As demonstrated in the Examples, the polynucleotides of the invention express GCCase activity at higher levels than wild type GBA.

25 Accordingly, in a first aspect of the invention, there is provided a polynucleotide comprising a GBA nucleotide sequence, wherein the GBA nucleotide sequence encodes a β -Glucocerebrosidase (GCCase) protein or fragment thereof and wherein at least a portion of the GBA nucleotide sequence is not wild type.

30 In a second aspect of the invention, there is provided a polynucleotide comprising a GBA nucleotide sequence, wherein the GBA nucleotide sequence encodes a GCCase protein or a

fragment thereof and comprises a sequence that is at least 95%, at least 96%, at least 97%, at least 98%, at least 99%, at least 99.5%, at least 99.8%, or 100% identical to a fragment of at least 1000, at least 1200, at least 1300, less than 1494, less than 1611, between 1000 and 1494, between 1000 and 1611, between 1300 and 1494, between 1300 and 1611, or
5 around 1494 nucleotides of SEQ ID NO: 1-8.

In a third aspect of the invention, there is provided a viral particle comprising a recombinant genome comprising the polynucleotide of the invention.

10 In a fourth aspect of the invention, there is provided a composition comprising the polynucleotide or viral particle of the invention and a pharmaceutically acceptable excipient.

In a fifth aspect of the invention, there is provided a method of treatment comprising
15 administering an effective amount of the polynucleotide or viral particle of the invention to a patient.

In a sixth aspect of the invention, there is provided a use of the polynucleotide, viral particle or composition of the invention in the manufacture of a medicament for use in a
20 method of treatment.

In a seventh aspect of the invention, there is provided the use of the polynucleotide, viral particle or composition of the invention in the manufacture of a medicament for achieving a stable GCase activity in a subject.
25

In an eighth aspect of the invention, there is provided the use of the polynucleotide, viral particle or composition of the invention in the manufacture of a medicament for providing greater GCase bioavailability in a subject compared to the bioavailability from GCase enzyme replacement therapy, wherein the bioavailability is measured over a period of 2
30 weeks from administration.

In a ninth aspect of the invention, there is provided a method of achieving a stable GCCase activity in a subject by administering to the subject the polynucleotide, viral particle or composition of the invention.

- 5 In a tenth aspect of the invention, there is provided a method of providing greater GCCase bioavailability in a subject compared to the bioavailability from GCCase enzyme replacement therapy by administering to the subject the polynucleotide, viral particle or composition of the invention, wherein the bioavailability is measured over a period of 2 weeks from administration.

10

In an eleventh aspect of the invention, there is provided a polynucleotide, viral particle or composition of the invention, for use in a method of expressing the GBA nucleotide sequence and achieving a stable GCCase activity in a subject.

- 15 In a twelfth aspect of the invention, there is provided a polynucleotide, viral particle or composition of the invention, for use in a method of expressing the GBA nucleotide sequence and providing greater GCCase bioavailability in a subject compared to the bioavailability from GCCase enzyme replacement therapy, wherein the bioavailability is measured over a period of 2 weeks from administration.

20

In a thirteenth aspect of the invention, there is provided the use of the polynucleotide, viral particle or composition of the invention in the manufacture of a medicament for reducing the levels of hexosylceramide and/or hexosylsphingosine in a subject suffering from a disease or condition associated with GCCase deficiency.

25

In a fourteenth aspect of the invention, there is provided a method of reducing the levels of hexosylceramide and/or hexosylsphingosine in a subject suffering from a disease or condition associated with GCCase deficiency by administering to the subject the polynucleotide, viral particle or composition of the invention.

30

In a fifteenth aspect of the invention, there is provided a polynucleotide, viral particle or composition of the invention, for use in a method of reducing levels of hexosylceramide and/or hexosylsphingosine in a subject suffering from a disease or condition associated with GCase deficiency, optionally wherein reducing hexosylceramide and/or
5 hexosylsphingosine levels leads to the treatment of the disease or condition associated with GCase deficiency.

Description of the Figures

10 **Figure 1** – Schematics of the GBA cassettes from the constructs FLF-PL01, FLF-PL28, and FLF-PL64. LSP-S and LSP-L: liver specific promoters; GBAAwt: wild type human GBA nucleotide sequence; GBAAco: human GBA nucleotide sequence codon-optimised (except for stretch encoding signal peptide, the end of which is represented by a dotted line).

15

Figure 2 – Dose-dependent liver expression and secretion of human GCase into murine bloodstream following AAV2/8-FLF-PL28 injection. (A) Representative image of mouse livers stained for GCase 12-weeks post AAV2/8-PL28 injection. DAB (3,3'-
Diaminobenzidine) was used to visualize GCase and haematoxylin was used as
20 counterstain. (B) Levels of GCase as measured by activity assay in serum of mice treated with increased doses of AAV2/8-PL28. n=5, C57BL/6 mice in each treatment group. Error bars show mean \pm SD.

Figure 3 – Relative GCase levels observed for each tested GBA codon-optimised construct
25 (FLF-PL16 to FLF-PL36; '16' to '36') upon transfection onto Huh-7 cells. Each construct was tested independently in 3 to 5 experiments. Data shown here represent GCase activity relative to wild type GBA construct FLF-PL01 ('01'). Error bars represent mean \pm SD.

Figure 4 – Measurement of GCase activity present in the mouse bloodstream upon
30 injection of vectors AAV2/8- FLF-PL- 01, 21, 28, 30, 36 and 37 (see example 5 for description of constructs). (A) GCase activity levels found in mouse serum 8-weeks after

injection of tested GBA constructs. (B) GCCase activity levels observed in mouse serum at 4-, 8-, 12-, and 36-weeks post-injection of constructs FLF-PL01 and FLF-PL28. Error bars represent mean \pm SD, n = 5-8 animals per experimental group. * $p \leq 0.05$; ** $p \leq 0.001$ (one-way ANOVA).

5

Figure 5 – Uptake levels of GCCase in spleen and bone marrow tissue following AAV2/8-FLF-PL28 injection in wild type mice. Representative image of spleen and bone marrow tissue stained for GBA is shown for naïve or AAV2/8-PL28 treatment mice at 4-weeks post-injection. DAB (3,3'-Diaminobenzidine) was used to visualize GBA and

10 haematoxylin was used as counterstain.

Figure 6 – Levels of co-localization of human GCCase with canonical murine macrophage marker F4/80 observed in spleen upon injection of wild type mice with AAV2/8-FLF-PL28. Representative immunofluorescence image of spleen tissue stained for GBA and

15 F4/80 antibodies. DAPI (Blue) was used to visualise nuclei.

Figure 7 – Levels of GCCase activity found in mouse bloodstream 4 weeks post-injection of AAV2/8-FLF-PL28 and FLF-PL64. GCCase activity was determined for mouse serum collected 4-weeks post-injection at the dose of 2×10^{12} vg/kg. Error bars represents mean \pm

20 SD. N = 5, C57BL/6 mice in each treatment group.

Figure 8 – Uptake levels observed in spleen, bone marrow and lung following AAV2/8-FLF-PL28 and FLF-PL64 injection observed in mice 5-weeks post treatment.

25 **Figure 9** - Sequence listing.

Figure 10 - Levels of GCCase secretion by human-derived cell lines following transduction with AAV-FLF-PL64. Cells were transduced at a MOI of 1×10^5 vg/cell with the vector AAV-FLF-PL64. (A) Levels of active GBA were determined fluorometrically with 4MU-Glc as the substrate. (B) The level of transduction for each cell line was obtained by qPCR using primers specific for the polyA sequence. Blank values for each cell line were

30

subtracted to obtain a value for the level of active GCCase. Error bars represent mean \pm SD of duplicate wells.

Figure 11: (A) Enzyme replacement therapy (VPRIV $\text{\textcircled{R}}$ (60 U/kg)) pharmacokinetics and half-life calculation in wild type mice. One-phase decay model equation: Y_0 is the Y-value when X (time) is zero. Plateau is the Y-value at infinite times. K is the rate constant. Tau is the time constant. Half-life is in the time units of the X-axis. Span is the difference between Y_0 and Plateau. (B) Comparison between serum pharmacokinetic profile of GCCase activity after a single injection of enzyme replacement therapy (VPRIV (60 U/kg), solid black) and gene therapy with FLF-PL64, following administration in wild type mice.

Figure 12: GCCase immunostaining in murine liver, spleen and bone following administration of VPRIV or FLF-PL64. DAB (3,3'-Diaminobenzidine) was used to visualise GCCase and haematoxylin was used as counterstain. FLF-PL64 samples were obtained at five weeks post-injection, while VPRIV treated samples were collected at the time labelled. Each image represents $n=5$, C57BL/6 mice for each treatment group. All pictures are at the same magnification.

Figure 13: Increase in GCCase activity observed in $gba^{9v/null}$ mouse liver (a), white blood cells (b), spleen (c), and bone marrow (d) upon administration of velaglycerase alfa (VPRIV $\text{\textcircled{R}}$) (labelled ERT) or AAV-GBA (AAV-FLF-PL64). ERT samples were collected 1-2 hours post the last injection corresponding to peak of uptake in tissues. AAV-GBA (AAV-FLF-PL64) samples were collected 12 weeks post-injection and corresponding to steady state levels of uptake. GCCase activity is represented as a percentage of the activity measured in wild-type healthy mice (at 20 weeks of age). All mice were treated at age of 8-week pre-overt symptomatology. ERT at dose 60 U/kg and administered by injection every two weeks; AAV-FLF-PL64 injected at dose of 2×10^{12} vg/kg. $n=10$. **** $P \leq 0.0001$

Figure 14: AAV-GBA (AAV-FLF-PL64) gene therapy reduces activated macrophages and inflammation in the liver of $gba^{9v/null}$ mice. Upper panel: H&E stained liver sections

showing a representative image from each group. Storage cells are identified by circles. Lower left panel: graph showing comparison between storage cells counted in AAV-FLF-PL64 and ERT treated groups compared to vehicle control groups. Lower right panel: graph showing CD68positive cells counted in AAV-FLF-PL64 and ERT treated groups compared to vehicle control groups following staining with anti-CD68 antibody. AAV-GBA (AAV-FLF-PL64) injected at dose of 2×10^{12} vg/kg; samples collected 12-weeks p.i. ERT at dose 60 U/kg and administered by injection every two weeks. ERT samples were collected 1-2 hours post the last injection. Mean \pm SEM, (n=10), ** $P \leq 0.005$, **** $P \leq 0.0005$

10

Figure 15: AAV-GBA (AAV-FLF-PL64) gene therapy shows better substrate clearance than velaglucerase alfa (VPRIV ®, labelled ERT) in $gba^{9v/null}$ mice. LC/MS analysis of hexosylceramide and hexosylsphingosine levels in liver, spleen, and bone marrow in AAV-FLF-PL64 and ERT treated groups. Levels were standardised to the levels measured in the vehicle control group. AAV-GBA (AAV-FLF-PL64) injected at dose of 2×10^{12} vg/kg; samples collected 12-weeks p.i.; ERT at dose 60 U/kg and administered by injection every two weeks. ERT samples were collected 1-2 hours post the last injection. Mean \pm SEM, (n=10), ** $P \leq 0.005$, **** $P \leq 0.0005$

20 Detailed Description

General definitions

Unless defined otherwise, technical and scientific terms used herein have the same meaning as commonly understood by a person skilled in the art to which this invention belongs.

In general, the term “*comprising*” is intended to mean including but not limited to. For example, the phrase “*a polynucleotide comprising a GBA nucleotide sequence*” should be interpreted to mean that the polynucleotide has a GBA nucleotide sequence, but the polynucleotide may contain additional nucleotides.

In some embodiments of the invention, the word “*comprising*” is replaced with the phrase “*consisting of*”. The term “*consisting of*” is intended to be limiting. For example, the phrase “*a polynucleotide consisting of a GBA nucleotide sequence*” should be understood
5 to mean that the polynucleotide has a GBA nucleotide sequence and no additional nucleotides.

As used herein, “*between*” when referring to two endpoints to define a range of values should be taken to mean “*between and including*”. Thus, a range defined as “*between 5
10 and 10*” includes all values greater than 5 and less than 10, as well as the discrete values 5 and 10 themselves.

The terms “*protein*” and “*polypeptide*” are used interchangeably herein, and are intended to refer to a polymeric chain of amino acids of any length.
15

For the purpose of this invention, in order to determine the percent identity of two sequences (such as two polynucleotide or two polypeptide sequences), the sequences are aligned for optimal comparison purposes (*e.g.*, gaps can be introduced in a first sequence for optimal alignment with a second sequence). The nucleotide or amino acid residues at
20 each position are then compared. When a position in the first sequence is occupied by the same nucleotide or amino acid residue as the corresponding position in the second sequence, then the nucleotides or amino acids are identical at that position. The percent identity between the two sequences is a function of the number of identical positions shared by the sequences (*i.e.*, % identity = number of identical positions /total number of
25 positions in the reference sequence x 100).

Typically the sequence comparison is carried out over the length of the reference sequence. For example, if the user wished to determine whether a given (“test”) sequence is 95% identical to SEQ ID NO: 1, SEQ ID NO: 1 would be the reference sequence. For example,
30 to assess whether a sequence is at least 80% identical to SEQ ID NO: 1 (an example of a reference sequence), the skilled person would carry out an alignment over the length of

SEQ ID NO: 1, and identify how many positions in the test sequence were identical to those of SEQ ID NO: 1. If at least 80% of the positions are identical, the test sequence is at least 80% identical to SEQ ID NO: 1. If the sequence is shorter than SEQ ID NO: 1, the gaps or missing positions should be considered to be non-identical positions.

5

The skilled person is aware of different computer programs that are available to determine the homology or identity between two sequences. For instance, a comparison of sequences and determination of percent identity between two sequences can be accomplished using a mathematical algorithm. In an embodiment, the percent identity between two amino acid or nucleic acid sequences is determined using the Needleman and Wunsch (1970) algorithm which has been incorporated into the GAP program in the Accelrys GCG software package (available at <http://www.accelrys.com/products/gcg/>), using either a Blosum 62 matrix or a PAM250 matrix, and a gap weight of 16, 14, 12, 10, 8, 6, or 4 and a length weight of 1, 2, 3, 4, 5, or 6.

15

For the purposes of the present invention, the term “*fragment*” refers to a contiguous portion of a sequence. For example, a fragment of SEQ ID NO: 1 of 50 nucleotides refers to 50 contiguous nucleotides of SEQ ID NO: 1.

20 *A polynucleotide*

In one aspect, the present invention provides a polynucleotide comprising a GBA nucleotide sequence, wherein the GBA nucleotide sequence encodes a β -Glucocerebrosidase (GCCase) protein or fragment thereof and wherein at least a portion of the GBA nucleotide sequence is not wild type.

25

The polynucleotide may further comprise one or more of the following features. The GBA nucleotide sequence, or portion of GBA nucleotide sequence that is not wild type, may be codon-optimised. The polynucleotide may (additionally) comprise a portion that is not codon-optimised. The polynucleotide may comprise an intron or a fragment of an intron.

30

The term “*polynucleotide*” refers to a polymeric form of nucleotides of any length, deoxyribonucleotides, ribonucleotides, or analogs thereof. For example, the polynucleotide may comprise DNA (deoxyribonucleotides) or RNA (ribonucleotides). The polynucleotide may consist of DNA. The polynucleotide may be mRNA. Since the
5 polynucleotide may comprise RNA or DNA, all references to T (thymine) nucleotides may be replaced with U (uracil).

A GBA nucleotide sequence encoding GCase

10 In one aspect, the polynucleotide provided herein comprises a GBA nucleotide sequence. The GBA nucleotide sequence typically encodes the β -Glucocerebrosidase (GCCase) protein or fragment thereof.

The term “*sequence that encodes*” refers to a nucleotide sequence comprising an open
15 reading frame comprising codons that encode the encoded polypeptide. For example, a nucleotide sequence that encodes a GCCase protein or fragment thereof comprises codons that encode the amino acid sequence of a GCCase protein or fragment thereof. An example of a GBA nucleotide sequence that encodes a wild type GCCase protein is provided in SEQ ID NO: 9.

20 A GBA nucleotide sequence may be interrupted by non-coding nucleotides (*e.g.* an intron), but only nucleotides that encode the polypeptide should be considered to be part of the GBA nucleotide sequence. For example, a GBA nucleotide sequence that encodes a GCCase protein will comprise any codons that encode an amino acid forming part of the
25 GCCase protein that is expressed from that coding sequence, irrespective of whether those codons are contiguous in sequence or separated by one or more non-coding nucleotides. In other words, a GBA polynucleotide which contains stretches of coding nucleotides interrupted by a stretch of non-coding nucleotides will be considered to comprise a “*GBA nucleotide sequence*” consisting of the non-contiguous coding stretches immediately
30 juxtaposed (*i.e.* minus the non-coding stretch). However, herein, the stop codon will be considered to be part of the full length coding sequence.

A GBA nucleotide sequence encoding GCase and/or a GCase coding sequence as described herein may also include codons for a signal peptide. It is well known that some proteins, particularly those which are exported to different tissues, are expressed with a signal peptide. Signal peptides can be at the N-terminus of a protein sequence (and in this case at the 5' end of a coding sequence) and many signal peptides are cleaved following cellular processing. Thus, herein, a mature protein or polypeptide (such as a mature GCase protein or polypeptide) will be considered to be the resulting protein or polypeptide after the signal peptide has been processed and removed/cleaved (and thus no longer forms part of the polypeptide sequence).

10

The following Table describes codons that encode each amino acid:

Amino Acid	Codon	Amino Acid	Codon	Amino Acid	Codon
Phenylalanine	TTC TTT	Proline	CCT CCC CCA CCG	Asparagine	AAT AAC
Leucine	TTA TTG CTT CTC CTA CTG	Threonine	ACT ACC ACA ACG	Lysine	AAA AAG
Isoleucine	ATT ATC ATA	Alanine	GCT GCC GCA GCG	Aspartic Acid	GAT GAC
Methionine	ATG	Tyrosine	TAT TAC	Glutamic Acid	GAA GAG
Valine	GTT GTC GTA GTG	Histidine	CAT CAC	Cysteine	TGT TGC
Serine	TCT TCC TCA TCG AGT AGC	Glutamine	CAA CAG	Tryptophan	TGG
Arginine	CGT	Glycine	GGT		

	CGC CGA CGG AGA AGG		GGC GGA GGG		
--	---------------------------------	--	-------------------	--	--

The corresponding RNA codons will contain Us in place of the Ts in the Table above.

One aspect of the present invention provides a polynucleotide comprising a GBA
 5 nucleotide sequence, wherein the GBA nucleotide sequence encodes a GCCase protein or a
 fragment thereof and comprises a sequence that is at least 95%, at least 96%, at least 97%,
 at least 98%, at least 99%, at least 99.5%, at least 99.8%, or 100% identical to a fragment
 of at least 1000, at least 1200, at least 1300, less than 1494, less than 1611, between 1000
 and 1494, between 1000 and 1611, between 1300 and 1494, between 1300 and 1611, or
 10 around 1494 nucleotides of any one of SEQ ID NO: 1-8. Optionally, all or a portion of
 the GBA nucleotide sequence is codon-optimised. In one embodiment, the GBA
 nucleotide sequence comprises a sequence that is at least 98% identical to a fragment of at
 least 1300 nucleotides of SEQ ID NO: 1-8. In one embodiment, the GBA nucleotide
 sequence comprises a sequence that is at least 99% identical to a fragment of at least 1300
 15 nucleotides of SEQ ID NO: 1-8.

In one example, the GBA nucleotide sequence may comprise a sequence that is at least
 95%, at least 98%, at least 99%, at least 99.5%, at least 99.8%, or 100% identical to SEQ
 ID NO: 1. In one embodiment, the GBA nucleotide sequence comprises a sequence that is
 20 at least 98% identical to a fragment of at least 1300 nucleotides of SEQ ID NO: 1. In one
 embodiment, the GBA nucleotide sequence comprises a sequence that is at least 99%
 identical to a fragment of at least 1300 nucleotides of SEQ ID NO: 1. The GBA
 nucleotide sequence may comprise a sequence that is at least 95%, at least 98%, at least
 99%, at least 99.5%, at least 99.8%, or 100% identical to SEQ ID NO: 5. The GBA
 25 nucleotide sequence may comprise a sequence that is at least 98% identical SEQ ID NO: 1.
 The GBA nucleotide sequence may comprise a sequence that is at least 99% identical SEQ
 ID NO: 1. The GBA nucleotide sequence may comprise a sequence that is at least 98%
 identical SEQ ID NO: 5. The GBA nucleotide sequence may comprise a sequence that is

at least 99% identical SEQ ID NO: 5. In one embodiment, the GBA nucleotide sequence may comprise SEQ ID NO: 1. In another embodiment, the GBA nucleotide sequence may comprise SEQ ID NO: 5.

5 The GBA nucleotide sequence may comprise a sequence of SEQ ID NO: 1 or a variant of SEQ ID NO: 1 encoding a GCCase protein having GCCase activity. In these examples, a variant of SEQ ID NO: 1 is identical to SEQ ID NO: 1 except that it comprises nucleotide substitutions such that the GCCase protein has 1, up to 2, up to 3, up to 4, up to 5, up to 6, up to 7, up to 8, up to 9, or up to 10 amino acid substitutions relative to the wild type GCCase amino acid sequence of SEQ ID NO: 25. In these examples, the variant of SEQ ID NO: 1 may have 1, up to 2, up to 3, up to 4, up to 5, up to 6, up to 7, up to 8, up to 9, up to 10, up to 20, or up to 30 nucleotide substitutions relative to the sequence of SEQ ID NO: 1. The variant of SEQ ID NO: 1 may have 1, up to 2, up to 3, up to 4, up to 5, or up to 6 nucleotide substitutions relative to the sequence of SEQ ID NO: 1. In one example, the variant of SEQ ID NO: 1 has up to 4 nucleotide substitutions relative to the sequence of SEQ ID NO: 1 and/or encodes a GCCase protein having up to 3 amino acid substitutions relative to the wild type amino acid GCCase sequence of SEQ ID NO: 25. In one example, the variant of SEQ ID NO: 1 has up to 3 nucleotide substitutions relative to the sequence of SEQ ID NO: 1 and/or encodes a GCCase protein having up to 2 amino acid substitutions relative to the wild type GCCase amino acid sequence of SEQ ID NO: 25. In one example, the variant of SEQ ID NO: 1 has 1 nucleotide substitution relative to the sequence of SEQ ID NO: 1 and/or encodes a GCCase protein having up to 1 amino acid substitution relative to the wild type GCCase amino acid sequence of SEQ ID NO: 25.

25 The GBA nucleotide sequence may comprise a sequence of SEQ ID NO: 5 or a variant of SEQ ID NO: 5 encoding a GCCase protein having GCCase activity. In these examples, a variant of SEQ ID NO: 5 is identical to SEQ ID NO: 5 except that it comprises nucleotide substitutions such that the GCCase protein has 1, up to 2, up to 3, up to 4, up to 5, up to 6, up to 7, up to 8, up to 9, or up to 10 amino acid substitutions relative to the wild type GCCase amino acid sequence of SEQ ID NO: 25. In these examples, the variant of SEQ ID NO: 5 may have 1, up to 2, up to 3, up to 4, up to 5, up to 6, up to 7, up to 8, up to 9, up to 10, up

to 20, or up to 30 nucleotide substitutions relative to the sequence of SEQ ID NO: 5. The variant of SEQ ID NO: 5 may have 1, up to 2, up to 3, up to 4, up to 5, or up to 6 nucleotide substitutions relative to the sequence of SEQ ID NO: 5. In one example, the variant of SEQ ID NO: 5 has up to 4 nucleotide substitutions relative to the sequence of SEQ ID NO: 5 and/or encodes a GCCase protein having up to 3 amino acid substitutions relative to the wild type amino acid GCCase sequence of SEQ ID NO: 25. In one example, the variant of SEQ ID NO: 5 has up to 3 nucleotide substitutions relative to the sequence of SEQ ID NO: 5 and/or encodes a GCCase protein having up to 2 amino acid substitutions relative to the wild type GCCase amino acid sequence of SEQ ID NO: 25. In one example, the variant of SEQ ID NO: 5 has 1 nucleotide substitution relative to the sequence of SEQ ID NO: 5 and/or encodes a GCCase protein having up to 1 amino acid substitution relative to the wild type GCCase amino acid sequence of SEQ ID NO: 25.

GCCase protein or fragment thereof

15

The polynucleotide comprises a GBA nucleotide sequence that encodes a GCCase protein or fragment thereof.

β -glucocerebrosidase (GCCase) is an enzyme with glucosylceramidase activity (EC 3.2.1.45) that hydrolyses the beta-glucosidic linkage of the chemical glucocerebroside, an intermediate in glycolipid metabolism that is abundant in cell membranes. Mutations in the GBA gene (which encodes GCCase) can lead to an accumulation of glucocerebrosides in macrophages that infiltrate many vital organs, which manifests as Gaucher disease (GD). A typical wild type GCCase polypeptide is encoded by SEQ ID NO: 9.

25

GCCase (*e.g.* a GCCase of SEQ ID NO: 25 encoded by SEQ ID NO: 9) is initially expressed as a precursor “*immature*” form, comprising a signal peptide (amino acid residues 1 to 39 of SEQ ID NO: 25 and codons 1 to 39 of SEQ ID NO: 9), and a mature GCCase polypeptide region. After processing, the “*mature*” form of GCCase lacks the signal peptide. The term “*mature GCCase*” or “*mature GCCase polypeptide*” refers to a GCCase polypeptide that does not comprise the signal peptide, such as a GCCase encoded by SEQ ID NOs: 1-4. A typical

30

GCCase signal peptide may be encoded by a nucleotide sequence of SEQ ID NO: 17 and have the polypeptide sequence of SEQ ID NO: 18.

5 The GCCase or fragment thereof may be a variant GCCase or fragment thereof, *i.e.* a GCCase that does not have a sequence identical to SEQ ID NO: 25. In an embodiment, the GCCase or fragment thereof that is encoded by a polypeptide of the present invention and/or by a GBA nucleotide sequence is at least 95%, at least 98%, at least 99%, at least 99.5%, at least 99.8%, or 100% identical to SEQ ID NO: 25; or at least 95%, at least 98%, at least 99%, at least 99.5%, at least 99.8%, or 100% identical to a fragment of SEQ ID NO: 25 at
10 least 300, at least 350, at least 400, less than or equal to 536, less than or equal to 497, between 300 and 536, or between 300 and 497 amino acids in length. In an embodiment, the GCCase protein or fragment thereof is at least 95%, at least 98%, at least 99%, at least 99.5%, at least 99.8%, or 100% identical to SEQ ID NO: 25; or at least 95%, at least 98%, at least 99%, at least 99.5%, at least 99.8%, or 100% identical to a fragment of SEQ ID
15 NO: 25 about 497 amino acids in length. The GCCase protein or fragment thereof may have a sequence of SEQ ID NO: 25. Preferably the GCCase protein or a fragment thereof does not comprise the signal peptide of SEQ ID NO: 18. Preferably the GCCase protein or fragment thereof is functional. A functional GCCase protein or fragment is one which carries out hydrolysis of glucocerebroside.

20

The GBA nucleotide sequence may encode a GCCase protein having 1, up to 2, up to 3, up to 4, or up to 5 amino acid substitutions relative to the wild type GCCase amino acid sequence of SEQ ID NO: 25. In such examples, the GBA nucleotide sequence may encode a GCCase protein having up to 3 amino acid substitutions relative to the wild type GCCase
25 amino acid sequence of SEQ ID NO: 25. The GBA nucleotide sequence may encode a GCCase protein having up to 2 amino acid substitutions relative to the wild type GCCase amino acid sequence of SEQ ID NO: 25. The GBA nucleotide sequence may encode a variant GCCase protein having up to 1 amino acid substitution relative to the wild type GCCase amino acid sequence of SEQ ID NO: 25.

30

It is within the abilities of the person skilled in the art to determine whether a GCCase protein or fragment encoded by a GBA nucleotide sequence is functional. The skilled person merely needs to express the GCCase nucleotide sequence, and test whether the expressed protein is active. For example, the skilled person could prepare a viral particle
5 of the invention comprising a GBA nucleotide sequence linked to an operable promoter, and transduce cells with the viral particle under conditions suitable for expression of the GCCase protein or fragment thereof. The activity (amount) of the expressed GCCase protein or fragment thereof can be analysed using a fluorometric assay, such as the “*serum GBA activity assay*” described in Example 1.

10

For example, a suitable fluorogenic assay is as follows. β -Glucocerebrosidase (acid β -glucosidase; GCCase) activity can be determined fluorometrically with 4-Methylumbelliferyl- β -D-glucopyranoside (4MU-Glc) as a substrate. Briefly, serum samples (0.5 μ L, diluted 1:50) can be assayed in 50 mM Sodium Citrate, 25 mM
15 Taurocholate, pH ~5.75, 6 mM 4MU-Glc, for 30 min at 37°C. Relative fluorescence levels (RFU) may then be evaluated using excitation and emission wavelengths of 365 nm and 445 nm, respectively. GCCase is expressed as nanomoles/h/ mL of serum based on a 4-Methylumbelliferone (4-MU) standard curve.

20 *A portion of the GBA nucleotide sequence is not wild type*

A portion of the GBA nucleotide sequence, for example the coding sequence that encodes GCCase protein or a fragment thereof, may not be wild type. The wild type GCCase-encoding GBA nucleotide sequence is represented by SEQ ID NO: 9, and a GBA
25 nucleotide sequence that comprises a portion differing in sequence from that of SEQ ID NO: 9 comprises a portion that is not wild type.

In an embodiment, the portion of the GBA nucleotide sequence that is not wild type is codon-optimised. Codon-optimisation can improve expression of the nucleotide sequence,
30 for example a GBA nucleotide sequence, in a particular tissue and/or in a particular organism. For example, if a nucleotide sequence is codon-optimised for expression in the

human liver, the nucleotide sequence is modified to increase the number of codons that may be favoured (in the sense that such codons correspond to tRNA species which are more abundant than other tRNA species specific for the same amino acid) in the human liver. The skilled person would appreciate that codon-optimising a sequence may not
5 entail changing every codon, not least because a “*favoured codon*” may already be present at some positions.

Such codon-optimisation may be subject to other factors. For example, it can be seen that the presence of CpGs has an adverse effect on expression and so the user may decide not to
10 use favoured codons at positions where doing so introduces CpGs into the sequence; this will still be considered to be codon-optimisation. In an embodiment, a favoured codon that ends with a C nucleotide will not be included in the portion of the coding sequence that is codon-optimised, where the next codon in the sequence begins with a G. For example, codon CTC encodes leucine. In schemes where CTC is a favoured codon, it should not be
15 used for encoding leucine where the next codon in the sequence begins with a G, such as codon GTT (or alternatively, the next codon – where possible – could be selected to avoid a G at the first position).

It is straightforward to determine the frequency of each codon used in a portion of a
20 nucleotide sequence. The skilled person merely needs to enter the sequence of that portion into one of the readily-available algorithms that looks at codon usage and review the results. Alternatively, the user could simply count them.

In one embodiment, a polynucleotide of the invention comprises a GBA nucleotide
25 sequence wherein 67% of the codons that encode histidine are CAC and 33% of the codons that encode histidine are CAT.

Optionally, the portion of the GBA nucleotide sequence that is codon-optimised is codon-optimised for expression in human liver cells. Optionally, the GBA nucleotide sequence is
30 codon-optimised for expression in the human liver. Optionally, the portion of the GBA nucleotide sequence that is codon-optimised is a contiguous portion.

The portion that is codon-optimised can correspond to a sequence encoding part of, or an entire, GCCase protein. For example, the coding sequence could be full-length (such as SEQ ID NO: 9), including the signal peptide which is not part of the mature GCCase protein, and the entire coding sequence could be codon-optimised. Hence, reference herein to “a portion of the GBA sequence is codon-optimised” should be understood to mean “at least a portion of the GBA sequence is codon-optimised”. Optionally, the portion of the GBA nucleotide sequence that is codon-optimised is at least 1000, at least 1200, at least 1300, less than 1600, less than 1500, between 1000 and 1600, between 1000 and 1500, between 1300 and 1500, or around 1494 nucleotides in length. Optionally, the portion of the GBA nucleotide sequence that is codon-optimised encodes (corresponds to) a mature GCCase protein. For example, the GBA nucleotide sequence may encode a precursor GCCase protein (*i.e.* including signal peptide), and if the portion of the GBA nucleotide sequence that is codon-optimised corresponds to the mature GCCase protein, the signal peptide is not codon-optimised.

Thus in some embodiments, a portion of the GBA nucleotide sequence may not be codon-optimised, for example a portion of the coding sequence is not codon-optimised for expression in the liver. In some embodiments, the portion that is not codon-optimised is at least 80, at least 90, at least 100, at least 110, less than 200, less than 170, less than 140, or around 117 nucleotides. In some embodiments, the portion that is not codon-optimised in a GBA nucleotide sequence is the portion which encodes the signal peptide.

As discussed above, providing a polynucleotide sequence comprising a GBA nucleotide sequence that is partially or wholly codon-optimised can ensure that the encoded polypeptide (*i.e.* a GCCase polypeptide) is expressed at a high level. It will be appreciated by one skilled in the art that expression of GCCase from a polynucleotide sequence, such as a GBA nucleotide sequence of the present invention, or from a viral particle of the present invention, generally requires the presence of a promoter sequence or region upstream of and/or operably linked to the polynucleotide sequence. Thus in one embodiment, the present invention provides a polynucleotide comprising a GBA nucleotide sequence,

wherein the GBA nucleotide sequence encodes a GCase polypeptide which is expressed in human liver cells at high levels when the GBA nucleotide sequence is operably linked to a promoter sequence. In some embodiments, the promoter sequence may be part of a transcriptional regulatory element. In some embodiments, the promoter sequence may be a liver-specific promoter sequence. In one embodiment, the promoter sequence is a promoter having SEQ ID NO: 12. In another embodiment, the promoter sequence is a promoter having SEQ ID NO: 15.

It will also be appreciated by one skilled in the art that making comparisons between polynucleotides or vectors of the invention and reference (comparator) polynucleotides or vectors such as a reference polynucleotide or a viral particle comprising a GBA nucleotide sequence of SEQ ID NO: 9, the reference polynucleotides or vectors may be identical to the polynucleotides or vectors of the invention except that the GBA nucleotide sequences are different. In other words, the different GBA nucleotide sequences being compared may be operably linked to the same promoter sequence. In some embodiments, the different GBA nucleotide sequences being tested may be operably linked to different (specified) promoter sequences.

Thus, in one embodiment, a GCase polypeptide encoded by the GBA nucleotide sequence is expressed in human liver cells at higher levels compared to a reference wild type GBA sequence. The reference wild type GBA nucleotide sequence may be SEQ ID NO: 9. In an embodiment, a polypeptide encoded by the GBA nucleotide sequence is expressed in human liver cells at higher levels compared to a polypeptide encoded by a nucleotide sequence comprising a GBA nucleotide sequence of SEQ ID NO: 9 and a promoter element of SEQ ID NO: 13 (wherein the GBA nucleotide sequence of SEQ ID NO: 9 and the promoter element of SEQ ID NO: 13 are preferably operably linked). In an embodiment, a polypeptide encoded by the GBA nucleotide sequence is expressed in human liver cells at higher levels compared to a polypeptide encoded by a nucleotide sequence comprising a GBA nucleotide sequence of SEQ ID NO: 9 and a transcription regulatory element of SEQ ID NO: 10 (wherein the GBA nucleotide sequence of SEQ ID NO: 9 and the promoter element of SEQ ID NO: 10 are preferably operably linked). In

such embodiments the GCase encoded by the GBA nucleotide sequence may be expressed in human liver cells at least 1.1x, at least 1.2x, at least 1.3x, at least 1.4x, or at least 1.5x higher. In an embodiment, a GCase polypeptide encoded by the GBA nucleotide sequence is expressed in human liver cells at higher or non-statistically significant different levels compared to a polypeptide encoded by an otherwise identical reference polynucleotide comprising a GBA nucleotide sequence of SEQ ID NO: 9 operably linked to a promoter of SEQ ID NO: 13, wherein the two polynucleotides are delivered to the cells in the same way and in the same amounts.

10 In one embodiment, when the polynucleotide sequence comprising a GBA nucleotide sequence is administered to a subject, or a non-human mammal such as a mouse, the GCase is present in the serum of the subject or non-human animal at higher levels (for example, at 4 or 8 or 12 weeks post-administration) compared to GCase encoded by an otherwise identical nucleotide sequence comprising a GBA nucleotide sequence of SEQ ID NO: 9 operably linked to a promoter element of SEQ ID NO: 12, 13 or 15, wherein the polynucleotides comprising the GBA nucleotide are administered in the same way and in the same amounts.

The skilled person may determine whether GCase is expressed from a given GBA nucleotide sequence (for example, a codon-optimised GBA nucleotide sequence) at higher levels compared to a reference sequence (for example, a wild type GBA nucleotide sequence, such as SEQ ID NO: 9) by transducing some cells with a viral particle comprising the GBA nucleotide sequence, and some cells with a particle comprising the reference sequence. The cells may be cultured under conditions suitable for expressing the GCase protein or fragment thereof encoded by the GBA nucleotide sequence, and the level of expressed GCase protein can be compared. The level of expressed GCase protein can be assessed using a fluorometric assay as described in the section entitled "*GCase protein or fragment thereof*", or an ELISA using a GCase-specific antibody. Suitable cells include cultured human liver cells, such as Huh-7 cells.

30

As discussed above, the presence of CpGs (*i.e.* CG dinucleotides) may reduce expression efficiency. This is because CpGs may be methylated, and their methylation may lead to gene silencing thereby reducing expression. Also, it is possible that high CpG content could trigger a TLR response, increasing the risk of an anti-AAV immune response. For this reason, it is preferred that the portion of the coding sequence that is codon-optimised comprises a reduced number of CpGs compared to a corresponding portion of a reference wild type GBA nucleotide sequence (such as SEQ ID NO: 9). In an embodiment, the portion of the GBA nucleotide sequence that is codon-optimised (which may be all of the GBA nucleotide sequence) comprises less than 40, less than 20, less than 10, or less than 5 CpGs. In an embodiment, the portion of the GBA nucleotide sequence that is codon-optimised (which may be all of the GBA nucleotide sequence) comprises less than 5, less than 4, less than 3, or less than 2 CpGs per 100 nts. In some embodiments, the portion of the coding sequence that is codon-optimised is CpG-free, *i.e.* contains no (0) CG dinucleotides.

15

In an embodiment, the portion of the GBA nucleotide sequence that is codon-optimised is at least 80%, at least 85%, at least 90%, at least 95%, at least 98%, at least 99%, at least 99.5%, at least 99.8%, or 100% identical to a fragment of at least 1000, at least 1200, at least 1300, less than 1494, between 1000 and 1494, between 1300 and 1494, or around 1494 nucleotides of SEQ ID NO: 1-4. In an embodiment, the portion of the coding sequence that is codon-optimised is at least 80%, at least 85%, at least 90%, at least 95%, at least 98%, at least 99%, at least 99.5%, at least 99.8%, or 100% identical to SEQ ID NO: 1-4. In an embodiment, the portion of the GBA nucleotide sequence that is codon-optimised is at least 80%, at least 85%, at least 90%, at least 95%, at least 98%, at least 99%, at least 99.5%, at least 99.8%, or 100% identical to a fragment of at least 1000, at least 1200, at least 1300, less than 1494, between 1000 and 1494, between 1300 and 1494, or around 1494 nucleotides of SEQ ID NO: 1. In an embodiment, the portion of the GBA nucleotide sequence that is codon-optimised is at least 99.5%, at least 99.8%, or 100% identical to a fragment of at least 1300 nucleotides of SEQ ID NO: 1. In an embodiment, the portion of the coding sequence that is codon-optimised is at least 80%, at least 85%, at

30

least 90%, at least 95%, at least 98%, at least 99%, at least 99.5%, at least 99.8%, or 100% identical to SEQ ID NO: 1.

5 The present invention provides a polynucleotide comprising a GBA nucleotide sequence that encodes a GCCase protein or a fragment thereof and the GBA sequence comprises a sequence that is at least 95%, at least 98%, at least 99%, at least 99.5%, at least 99.8%, or 100% identical to SEQ ID NO: 1. Optionally, the sequence that is at least 95%, at least 98%, at least 99%, at least 99.5%, or at least 99.8% identical to SEQ ID NO: 1 is codon-optimised.

10

Portion of the coding sequence that is not codon-optimised

In an embodiment, the GBA nucleotide sequence comprises a portion that is not codon-optimised. The portion that is not codon-optimised may be a contiguous portion.

15

As would be understood in the art, the portion that is not codon-optimised is therefore not modified to include a greater number of favoured codons compared to the wild type sequence. A contiguous non-codon-optimised polynucleotide sequence is a wild type sequence.

20

Optionally, the portion that is not codon-optimised is at least 80, at least 90, at least 100, at least 110, less than 200, less than 170, less than 140, or around 117 nucleotides. In some embodiments, the portion that is not codon-optimised in a GBA nucleotide sequence is the portion which encodes (corresponds to) all or a portion of the signal peptide. Optionally, 25 the portion that is not codon-optimised encodes all or a portion of a GCCase signal peptide. In some embodiments, the portion that is not codon-optimised in a GBA nucleotide sequence is a portion having a sequence of SEQ ID NO: 17.

30

The polynucleotide may further comprise a transcription regulatory element

The polynucleotide may comprise a transcription regulatory element.

In one embodiment, the transcription regulatory element is at least 80%, at least 85%, at least 90%, at least 95%, at least 98%, at least 99%, at least 99.5%, at least 99.8%, or 100% identical to SEQ ID NO: 10. In an embodiment, the polynucleotide comprises a
5 transcription regulatory element that is at least 98%, at least 99%, at least 99.5%, at least 99.8%, or 100% identical to SEQ ID NO: 10. Optionally, the polynucleotide comprises a transcription regulatory element at least 98% identical to SEQ ID NO: 10. Optionally, the polynucleotide comprises a transcription regulatory element of SEQ ID NO: 10.
10 Optionally, the polynucleotide comprises a transcription regulatory element consisting of SEQ ID NO: 10.

In another embodiment, the transcription regulatory element is at least 80%, at least 85%, at least 90%, at least 95%, at least 98%, at least 99%, at least 99.5%, at least 99.8%, or 100% identical to SEQ ID NO: 14. In an embodiment, the polynucleotide comprises a
15 transcription regulatory element that is at least 98%, at least 99%, at least 99.5%, at least 99.8%, or 100% identical to SEQ ID NO: 14. Optionally, the polynucleotide comprises a transcription regulatory element at least 98% identical to SEQ ID NO: 14. Optionally, the polynucleotide comprises a transcription regulatory element of SEQ ID NO: 14.
20 Optionally, the polynucleotide comprises a transcription regulatory element consisting of SEQ ID NO: 14.

Any appropriate transcription regulatory element may be used, such as HLP2, HLP1, LP1, HCR-hAAT, ApoE-hAAT, and LSP, which are all liver-specific transcription regulatory elements. These transcription regulatory elements are described in more detail in the
25 following references: HLP1: McIntosh J. *et al.*, Blood 2013 Apr 25, 121(17):3335-44; LP1: Nathwani *et al.*, Blood. 2006 April 1, 107(7): 2653–2661; HCR-hAAT: Miao *et al.*, Mol Ther. 2000;1: 522-532; ApoE-hAAT: Okuyama *et al.*, Human Gene Therapy, 7, 637-645 (1996); and LSP: Wang *et al.*, Proc Natl Acad Sci U S A. 1999 March 30, 96(7): 3906–3910.

30

The transcription regulatory element may comprise a promoter and/or an enhancer, such as the promoter element and/or enhancer element from HLP2, HLP1, LP1, HCR-hAAT, ApoE-hAAT, and LSP. Each of these transcription regulatory elements comprises a promoter, an enhancer, and optionally other nucleotides.

5

In an embodiment, the transcription regulatory element comprises an enhancer which is the human apolipoprotein E (ApoE) hepatic locus control region (HCR; Miao et al (2000), Molecular Therapy 1(6):522), or a fragment thereof. In an embodiment, the transcription regulatory element comprises a fragment of the HCR enhancer which is a fragment of at least 80, at least 90, at least 100, less than 192, between 80 and 192, between 90 and 192, 10 between 100 and 250, or between 117 and 192 nucleotides in length. Optionally, the fragment of the HCR enhancer is between 100 and 250 nucleotides in length. In another embodiment, the fragment of an HCR enhancer is a fragment of at least 150, at least 190, at least 230, less than 400, between 150 and 400, between 190 and 370, between 230 and 15 340, between 250 and 340, or around 321 nucleotides in length. Optionally, the fragment of the HCR enhancer is between 250 and 340 nucleotides in length.

Suitable HCR enhancer element fragment are described in SEQ ID NOs: 11 and 16.

Optionally, the transcription regulatory element comprises an enhancer that is at least 80, 20 at least 90, at least 100, less than 192, between 80 and 192, between 90 and 192, between 100 and 250, or between 117 and 192 nucleotides in length and the enhancer comprises a polynucleotide sequence that is at least 80%, at least 85%, at least 90%, at least 95%, at least 98%, at least 99%, at least 99.5%, at least 99.8%, or 100% identical SEQ ID NO: 11. Optionally, the transcription regulatory element comprises an enhancer that is between 117 25 and 192 nucleotides in length and the enhancer comprises a polynucleotide sequence that is at least 98%, at least 99%, at least 99.5%, at least 99.8%, or 100% identical SEQ ID NO: 11. Optionally, the transcription regulatory element comprises an enhancer that is at least 80%, at least 85%, at least 90%, at least 95%, at least 98%, at least 99%, at least 99.5%, at least 99.8%, or 100% identical to a fragment of at least 90, at least 100, or at least 110 30 nucleotides of SEQ ID NO: 11. Optionally, the polynucleotide comprises an enhancer that is at least 80%, at least 85%, at least 90%, at least 95% at least 98%, at least 99%, at least

99.5%, at least 99.8%, or 100% identical to SEQ ID NO: 11. Optionally, the polynucleotide comprises an enhancer that is at least 98%, at least 99%, at least 99.5%, at least 99.8%, or 100% identical to SEQ ID NO: 11. Optionally, the polynucleotide comprises an enhancer of SEQ ID NO: 11. Optionally, the transcription regulatory element
5 comprises a fragment of an HCR enhancer that is equal to or less than 321 nucleotides, equal to or less than 192 nucleotides or equal to or less than 117 nucleotides in length and comprises SEQ ID NO: 11.

In another embodiment, the transcription regulatory element comprises an enhancer that is
10 at least 150, at least 190, at least 230, less than 400, between 150 and 400, between 190 and 370, between 230 and 340, between 250 and 340, or around 318 nucleotides in length and the enhancer comprises a polynucleotide sequence that is at least 80%, at least 85%, at least 90%, at least 95%, at least 98%, at least 99%, at least 99.5%, at least 99.8%, or 100% identical SEQ ID NO: 16. Optionally, the transcription regulatory element comprises an
15 enhancer that is between 250 and 340 nucleotides in length and the enhancer comprises a polynucleotide sequence that is at least 98%, at least 99%, at least 99.5%, at least 99.8%, or 100% identical SEQ ID NO: 16. Optionally, the transcription regulatory element comprises an enhancer that is at least 80%, at least 85%, at least 90%, at least 95%, at least 98%, at least 99%, at least 99.5%, at least 99.8%, or 100% identical to a fragment of at
20 least 250 nucleotides of SEQ ID NO: 16. Optionally, the polynucleotide comprises an enhancer that is at least 80%, at least 85%, at least 90%, at least 95% at least 98%, at least 99%, at least 99.5%, at least 99.8%, or 100% identical to SEQ ID NO: 16. Optionally, the polynucleotide comprises an enhancer that is at least 98%, at least 99%, at least 99.5%, at least 99.8%, or 100% identical to SEQ ID NO: 16. Optionally, the polynucleotide
25 comprises an enhancer of SEQ ID NO: 16.

In an embodiment, the transcription regulatory element comprises a promoter which is a human alpha-1 anti-trypsin promoter (A1AT; Miao et al (2000), Molecular Therapy 1(6):522), or a fragment thereof. Optionally, a fragment of an A1AT promoter which is at
30 least 100, at least 120, at least 150, at least 180, less than 255, between 100 and 255, between 150 and 225, between 150 and 300, or between 180 and 255 nucleotides in length.

Optionally, the fragment of an A1AT promoter is between 150 and 300 nucleotides in length. In another embodiment, a fragment of an A1AT promoter which at least 200, at least 250, at least 300, less than 500, between 200 and 500, between 250 and 500, or between 350 and 450 nucleotides in length. Optionally, the fragment of an A1AT promoter
5 is between 350 and 450 nucleotides in length.

Suitable A1AT promoter fragments are described in SEQ ID NOs: 12 and 15. Optionally, the transcription regulatory element comprises a promoter that is at least 100, at least 120, at least 150, at least 180, less than 255, between 100 and 255, between 150 and 300, or
10 between 180 and 255 nucleotides in length and the promoter comprises a polynucleotide sequence that is at least 80%, at least 85%, at least 90%, at least 95%, at least 98%, at least 99%, at least 99.5%, at least 99.8%, or 100% identical to SEQ ID NO: 12. Optionally, the transcription regulatory element comprises a promoter that is between 180 and 255 nucleotides in length and the promoter comprises a polynucleotide sequence that is at least
15 98%, at least 99%, at least 99.5%, at least 99.8%, or 100% identical to SEQ ID NO: 12. Optionally, the polynucleotide comprises a promoter that is at least 80%, at least 85%, at least 90%, at least 95%, at least 98%, at least 99%, at least 99.5%, at least 99.8%, or 100% identical to a fragment of at least 100, at least 120, or at least 150 nucleotides of SEQ ID NO: 12. Optionally, the polynucleotide comprises a promoter that is at least 80%, at least
20 85%, at least 90%, at least 95%, at least 98%, at least 99%, at least 99.5%, at least 99.8%, or 100% identical to SEQ ID NO: 12. Optionally, the polynucleotide comprises a promoter that is at least 98%, at least 99%, at least 99.5%, at least 99.8%, or 100% identical to SEQ ID NO: 12. Optionally, the polynucleotide comprises a promoter of SEQ ID NO: 12. Optionally, the transcription regulatory element comprises a fragment of an
25 A1AT promoter that is equal to or less than 418 nucleotides, equal to or less than 255 nucleotides or equal to or less than 185 nucleotides in length and comprises SEQ ID NO: 12.

In another embodiment, the transcription regulatory element comprises a promoter that is
30 at least 200, at least 250, at least 300, less than 500, between 200 and 500, between 250 and 500, between 350 and 450, or around 418 nucleotides in length and the promoter

comprises a polynucleotide sequence that is at least 80%, at least 85%, at least 90%, at least 95%, at least 98%, at least 99%, at least 99.5%, at least 99.8%, or 100% identical to SEQ ID NO: 15. Optionally, the transcription regulatory element comprises a promoter that is between 350 and 450 nucleotides in length and the promoter comprises a

5 polynucleotide sequence that is at least 98%, at least 99%, at least 99.5%, at least 99.8%, or 100% identical to SEQ ID NO: 15. Optionally, the polynucleotide comprises a promoter that is at least 80%, at least 85%, at least 90%, at least 95%, at least 98%, at least 99%, at least 99.5%, at least 99.8%, or 100% identical to a fragment of at least 350 nucleotides of SEQ ID NO: 15. Optionally, the polynucleotide comprises a promoter that is at least 80%,

10 at least 85%, at least 90%, at least 95%, at least 98%, at least 99%, at least 99.5%, at least 99.8%, or 100% identical to SEQ ID NO: 15. Optionally, the polynucleotide comprises a promoter that is at least 98%, at least 99%, at least 99.5%, at least 99.8%, or 100% identical to SEQ ID NO: 15. Optionally, the polynucleotide comprises a promoter of SEQ ID NO: 15.

15

If the polynucleotide is intended for expression in the liver, the promoter may be a liver-specific promoter. Optionally, the promoter is a human liver-specific promoter. A “*liver-specific promoter*” is a promoter that provides a higher level of expression in liver cells compared to other cells in general. For example, the skilled person can determine

20 whether a promoter is a liver-specific promoter by comparing expression of the polynucleotide in liver cells (such as Huh-7 cells) with expression of the polynucleotide in cells from other tissues. If the level of expression is higher in the liver cells, compared to the cells from other tissues, the promoter is a liver-specific promoter. Optionally, the transcription regulatory element or the promoter is liver-specific if it promotes protein

25 expression at higher levels in liver cells compared to cells from at least one other organ or tissue and the transcription regulatory element or the promoter promotes protein expression in the cells from at least one other organ or tissue at a level less than 40%, less than 30%, less than 25%, less than 15%, less than 10%, or less than 5% of the level that the transcription regulatory element or the promoter promotes protein expression in liver cells.

30 Optionally, the cells from at least one other organ or tissue are at least one of kidney cells, pancreatic cells, breast cells, neuroblastoma cells, lung cells, and early B cells. Optionally,

the cells from at least one other organ or tissue are kidney cells, pancreatic cells, breast cells, neuroblastoma cells, lung cells, and early B cells. Optionally, the cells from at least one other organ or tissue are at least one of HEK293T cells, PANC1 cells, BxPC-3 cells, MCF7 cells, 1643 cells, MRC-9 cells, and 697 cells. Optionally, the cells from at least one
5 other organ or tissue are HEK293T cells, PANC1 cells, BxPC-3 cells, MCF7 cells, 1643 cells, MRC-9 cells, and 697 cells.

In one embodiment, the polynucleotide of the invention may provide for GCCase to be specifically expressed in the liver. In such examples, the polynucleotide may promote
10 substantially more GCCase expression in liver cells than in at least one other tissue type or organ. In one example, the polynucleotide of the invention which provides for GCCase to be specifically expressed in the liver comprises a liver-specific promoter.

Optionally, the polynucleotide of the invention may provide for GCCase to be expressed at
15 higher levels in liver cells compared to cells from at least one other organ or tissue and such that GCCase is expressed in the one other organ or tissue at a level less than 40%, less than 30%, less than 25%, less than 15%, less than 10%, or less than 5% of the level of GCCase expression in liver cells, when measured in the same assay.

20 Optionally, the cells from at least one other organ or tissue are at least one of kidney cells, pancreatic cells, breast cells, neuroblastoma cells, lung cells, and early B cells. Optionally, the cells from at least one other organ or tissue are kidney cells, pancreatic cells, breast cells, neuroblastoma cells, lung cells, and early B cells. Optionally, the cells from at least one other organ or tissue are at least one of HEK293T cells, PANC1 cells, BxPC-3 cells,
25 MCF7 cells, 1643 cells, MRC-9 cells, and 697 cells. Optionally, the cells from at least one other organ or tissue are HEK293T cells, PANC1 cells, BxPC-3 cells, MCF7 cells, 1643 cells, MRC-9 cells, and 697 cells.

A viral particle comprising the polynucleotide

30

The invention further provides a viral particle comprising a recombinant genome comprising polynucleotides of the invention. For the purposes of the present invention, the term “*viral particle*” refers to all or part of a virion. For example, the viral particle comprises a recombinant genome and may further comprise a capsid. The viral particle
5 may be a gene therapy vector. Herein, the terms “*viral particle*” and “*vector*” are used interchangeably. For the purpose of the present application, a “*gene therapy*” vector is a viral particle that can be used in gene therapy, *i.e.* a viral particle that comprises all the required functional elements to express a transgene, such as a GBA nucleotide sequence, in a host cell after administration.

10

Suitable viral particles include a parvovirus, a retrovirus, a lentivirus or a herpes simplex virus. The parvovirus may be an adeno-associated virus (AAV). The viral particle is preferably a recombinant adeno-associated viral (AAV) vector or a lentiviral vector. More preferably, the viral particle is an AAV viral particle. The terms AAV and rAAV are used
15 interchangeably herein, unless context obviously suggests otherwise.

The genomic organization of all known AAV serotypes is very similar. The genome of AAV is a linear, single-stranded DNA molecule that is less than about 5,000 nucleotides in length. Inverted terminal repeats (ITRs) flank the unique coding nucleotide sequences for
20 the non-structural replication (Rep) proteins and the structural (VP) proteins. The VP proteins (VP1, -2 and -3) form the capsid. The terminal ~145 nt (ITRs) are self-complementary and are organized so that an energetically stable intramolecular duplex forming a T-shaped hairpin may be formed. These hairpin structures function as an origin for viral DNA replication, serving as primers for the cellular DNA polymerase complex.
25 Following wild type (wt) AAV infection in mammalian cells the Rep genes (*i.e.* encoding Rep78 and Rep52 proteins) are expressed from the P5 promoter and the P19 promoter, respectively, and both Rep proteins have a function in the replication of the viral genome. A splicing event in the Rep ORF results in the expression of four Rep proteins (*i.e.* Rep78, Rep68, Rep52 and Rep40). However, it has been shown that the unspliced mRNA,
30 encoding Rep78 and Rep52 proteins, in mammalian cells are sufficient for AAV vector

production. Also in insect cells the Rep78 and Rep52 proteins suffice for AAV vector production.

The recombinant viral genome of the invention may comprise ITRs. It is possible for an AAV vector of the invention to function with only one ITR. Thus, the viral genome comprises at least one ITR, but, more typically, two ITRs (generally with one either end of the viral genome, i.e. one at the 5' end and one at the 3' end). There may be intervening sequences between the polynucleotide of the invention and one or more of the ITRs. The polynucleotide may be incorporated into a viral particle located between two regular ITRs or located on either side of an ITR engineered with two D regions.

AAV sequences that may be used in the present invention for the production of AAV vectors can be derived from the genome of any AAV serotype. Generally, the AAV serotypes have genomic sequences of significant homology at the amino acid and the nucleic acid levels, provide an identical set of genetic functions, produce virions which are essentially physically and functionally equivalent, and replicate and assemble by practically identical mechanisms. For the genomic sequence of the various AAV serotypes and an overview of the genomic similarities see e.g. GenBank Accession number U89790; GenBank Accession number J01901; GenBank Accession number AF043303; GenBank Accession number AF085716; Chiorini *et al*, 1997; Srivastava *et al*, 1983; Chiorini *et al*, 1999; Rutledge *et al*, 1998; and Wu *et al*, 2000. AAV serotype 1, 2, 3, 3B, 4, 5, 6, 7, 8, 9, 10, 11 or 12 may be used in the present invention. The sequences from the AAV serotypes may be mutated or engineered when being used in the production of gene therapy vectors.

Optionally, an AAV vector comprises ITR sequences which are derived from AAV1, AAV2, AAV4 and/or AAV6. Preferably the ITR sequences are AAV2 ITR sequences. Herein, the term AAVx/y refers to a viral particle that comprises genomic components such as at least ITRs from AAVx (wherein x is a AAV serotype number) and has the capsid from AAVy (wherein y is the number of the same or different serotype). For example, an AAV2/8 vector may comprise a portion of a viral genome, including the ITRs, from an AAV2 strain, and a capsid from an AAV8 strain.

In an embodiment, the viral particle is an AAV viral particle comprising a capsid. AAV capsids are generally formed from three proteins, VP1, VP2 and VP3. The amino acid sequence of VP1 comprises the sequence of VP2. The portion of VP1 which does not form part of VP2 is referred to as VP1unique or VP1U. The amino acid sequence of VP2 comprises the sequence of VP3. The portion of VP2 which does not form part of VP3 is referred to as VP2unique or VP2U. Optionally, the viral particle comprises a liver-tropic or CNS-tropic capsid. Whether a viral particle (capsid) is tropic for a particular tissue can be evaluated for example by administering such a particle expressing a marker gene such as luciferase and imaging *in vivo* at multiple time points (for example as described in Zincarelli et al (2008), Molecular Therapy, 16:1073-1080). A particle driving strong marker expression in liver or CNS tissues, respectively, especially if in contrast to lesser expression in other tissues, would be considered liver- or CNS-tropic.

In some embodiments, a liver-tropic capsid can be an AAV3- or AAV3B-derived capsid. Optionally, the liver-tropic capsid comprises a sequence at least 98%, at least 99%, or at least 99.5% identical to a fragment of at least 600, at least 650, at least 700, between 600 and 736, between 650 and 736 or between 700 and 736 amino acids of SEQ ID NO: 19, 20, or 24. Optionally, the liver-tropic capsid comprises a sequence at least 99% identical to SEQ ID NO: 19. Optionally, the liver-tropic capsid comprises a sequence at least 99% identical to SEQ ID NO: 20. Optionally, the liver-tropic capsid comprises a sequence at least 99% identical to SEQ ID NO: 24. Optionally, the CNS tropic capsid comprises a sequence at least 98%, at least 99%, at least 99.5% identical to a fragment of at least 600, at least 650, at least 700, between 600 and 736, between 650 and 736 or between 700 and 736 amino acids of SEQ ID NO: 21. Optionally, the CNS-tropic capsid comprises a sequence at least 99% identical to SEQ ID NO: 21. A viral particle of the invention may be a "hybrid" particle in which the viral ITRs and viral capsid are from different parvoviruses, such as different AAV serotypes. Preferably, the viral ITRs and capsid are from different serotypes of AAV, in which case such viral particles are known as transcapsidated or pseudotyped. Likewise, the parvovirus may have a "chimeric" capsid (*e. g.*, containing

sequences from different parvoviruses, preferably different AAV serotypes) or a "targeted" capsid (e. g., a directed tropism).

In some embodiments, the recombinant AAV genome comprises intact ITRs, comprising
5 functional terminal resolution sites (TRS). Such an AAV genome may contain one or two
resolvable ITRs, i.e. ITRs containing a functional TRS at which site-specific nicking can
take place to create a free 3' hydroxyl group which can serve as a substrate for DNA
polymerase to unwind and copy the ITR. Preferably, the recombinant genome is single-
stranded (*i.e.*, it is packaged into the viral particle in a single-stranded form). Optionally,
10 the recombinant genome is not packaged in self-complementary configuration, *i.e.* the
genome does not comprise a single covalently-linked polynucleotide strand with
substantial self-complementary portions that anneal in the viral particle. Alternatively, the
recombinant genome may be packaged in "*monomeric duplex*" form. "*Monomeric
duplexes*" are described in WO 2011/122950. The genome may be packaged as two
15 substantially complementary but non-covalently linked polynucleotides which anneal in
the viral particle.

The viral particle may further comprise a poly A sequence. The poly A sequence may be
positioned downstream of the nucleotide sequence encoding a functional GCase protein.
20 The poly A sequence may be a bovine growth hormone poly A sequence (bGHpA – SEQ
ID NO: 23). The poly A sequence may be between 250 and 270 nucleotides in length.

The viral particle may further comprise an intron sequence, such as a viral intron sequence,
optionally an SV40 intron sequence (SEQ ID NO: 22).
25

In one embodiment, the viral particle comprises a polynucleotide sequence comprising a
promoter element, an intron sequence, such as an SV40 intron sequence, a GBA nucleotide
sequence, and a poly A sequence, such as the bGHpA sequence. In such embodiments,
the intron sequence, such as the SV40 intron sequence, may be located between the
30 promoter element and the GBA nucleotide sequence. In such embodiments, the poly A

sequence, such as the bGHpA sequence, may be located downstream of the GBA nucleotide sequence.

The viral particle of the invention optionally expresses GCase highly in host cells. For example, on transduction in Huh-7 cells, the viral particle of the present invention expresses GCase protein or a fragment thereof at a higher level compared to an otherwise identical viral particle comprising a GBA nucleotide sequence of SEQ ID NO: 9 transduced at a comparable amount into a comparable population of Huh-7 cells. Optionally, after transduction into a population of Huh-7 cells, the viral particle of the present invention expresses GCase protein at a higher level than a viral particle comprising a GBA nucleotide sequence of SEQ ID NO: 9 and a transcription regulatory element of SEQ ID NO: 10 or a promoter of SEQ ID NO: 12. Optionally, after transduction into a population of Huh-7 cells, the viral particle of the present invention expresses GCase protein at a higher level than a comparable viral particle comprising a GBA nucleotide sequence of SEQ ID NO: 9 and a transcription regulatory element of SEQ ID NO: 10 or a promoter sequence of SEQ ID NO: 12 transduced at a comparable amount into a comparable population of Huh-7 cells. Optionally, after transduction into a population of Huh-7 cells, the viral particle expresses GCase protein at comparable level (*i.e.* a non-statistically significantly different level) to a viral particle comprising a GBA nucleotide sequence of SEQ ID NO: 9 and a promoter element of SEQ ID NO: 13 transduced at a comparable amount into a comparable population of Huh-7 cells. In such embodiments, the term “*comparable viral particle*” refers to a viral particle that is the same as an AAV viral particle of the invention, except the comparable viral particle comprises a different GBA nucleotide sequence and a different transcription regulatory element. Optionally, the comparable viral particle comprises the same transcription regulatory element as the AAV viral particle of the invention. Optionally, the activity is assessed using a chromogenic assay such as the fluorometric assay discussed above.

In one embodiment, provided is a viral particle comprising a polynucleotide sequence, the polynucleotide sequence comprising:

- a) a GBA nucleotide sequence having at least 98% sequence identity to SEQ ID NO: 5, operably linked to:
- b) a transcriptional regulatory sequence having at least 98% sequence identity to SEQ ID NO: 14;
- 5 wherein the viral particle further comprises a capsid having at least 98% identity to SEQ ID NO: 20.

In one embodiment, provided is a viral particle comprising a polynucleotide sequence, the polynucleotide sequence comprising:

- 10 a) a GBA nucleotide sequence having at least 98% sequence identity to SEQ ID NO: 5, operably linked to:
- b) a transcriptional regulatory sequence having at least 98% sequence identity to SEQ ID NO: 10;
- wherein the viral particle further comprises a capsid having at least 98% identity to SEQ
- 15 ID NO: 20.

Compositions, methods and uses

In a further aspect of the invention, there is provided a composition comprising the

20 polynucleotide or vector/viral particle of the invention and a pharmaceutically acceptable excipient.

The pharmaceutically acceptable excipients may comprise carriers, diluents and/or other medicinal agents, pharmaceutical agents or adjuvants, etc. Optionally, the

25 pharmaceutically acceptable excipients comprise saline solution. Optionally, the pharmaceutically acceptable excipients comprise human serum albumin.

This invention further provides a method of expressing the GBA nucleotide sequence and achieving a stable GCcase activity in a subject and/or providing greater GCcase

30 bioavailability in a subject compared to the bioavailability from GCcase enzyme replacement therapy, wherein the bioavailability is measured over a period of 2 weeks

from administration, wherein the method comprises administration of a polynucleotide, viral particle or composition of the invention to a subject.

The invention further provides a polynucleotide, vector/viral particle or composition of the invention for use in a method of treatment. Optionally the method of treatment comprises administering an effective amount of the polynucleotide or vector/viral particle of the invention to a patient.

The invention further provides a method of treatment comprising administering an effective amount of the polynucleotide or vector/viral particle of the invention to a patient.

The invention further provides use of the polynucleotide, vector/viral particle or composition of the invention in the manufacture of a medicament for use in a method of treatment. Optionally the method of treatment comprises administering an effective amount of the polynucleotide or vector/viral particle of the invention to a patient. Optionally the method of treatment is a gene therapy. A “*gene therapy*” involves administering a vector/viral particle of the invention that is capable of expressing a transgene (such as a GBA nucleotide sequence) in the host to which it is administered.

Optionally, the method of treatment is a method of treating diseases associated with a GCase deficiency. As discussed above, GCase deficiency may lead to accumulation of glucocerebrosides in macrophages that infiltrate many vital organs which can cause a variety of diseases including synucleopathies (as discussed in WO08/144591) or Parkinson’s disease. Optionally, the method of treatment is a method of treating Parkinson’s disease or a synucleopathy.

Optionally, the method of treatment is a method of treating a lysosomal storage disorder such as Gaucher disease (GD), for example GD type I, type II or type III. Preferably, the lysosomal storage disorder is characterised by bruising, fatigue, anemia, low blood platelet count and enlargement of the liver and spleen. Optionally, the method of treatment is a method of treating GD, for example GD type I. In some embodiments, the patient is a

patient suffering from GD, for example GD type I. Optionally the patient has antibodies or inhibitors to recombinant GCCase (for example imiglucerase, velaglucerase alfa or taliglucerase alfa) with which the patient has previously been treated as part of an enzyme replacement therapy. Optionally, the polynucleotide and/or vector/viral particle is
5 administered intravenously. Optionally, the polynucleotide and/or vector/viral particle is for administration only once (i.e. a single dose) to a patient.

When GD is "*treated*" in the above method, this means that one or more symptoms of GD type I are ameliorated. It does not mean that the symptoms of GD type I are completely
10 remedied so that they are no longer present in the patient, although in some methods, this may be the case. Thus, in all instances the term "*treatment*" can be replaced with the term "*amelioration*". The method of treatment may result in one or more of the symptoms of GD type I being less severe than before treatment. Optionally, relative to the situation pre-administration, the method of treatment results in an increase in the amount/concentration
15 of circulating GCCase in the blood of the patient, and/or the overall level of GCCase activity detectable within a given volume of blood and/or the macrophages of the patient. In one embodiment, relative to the situation pre-administration, the method of treatment results in one or more of: an increase in haemoglobin concentration; an increase in platelet count; a decrease in spleen size; a decrease in liver size.

20

In addition, the methods of the invention may "*prevent*" diseases such as Gaucher disease. Gaucher disease is generally associated with an accumulation of glucocerebrosidases in various tissues, and if the methods of the invention are carried out on young subjects (such as teenagers, young adults, children or babies) it should be possible to prevent Gaucher
25 disease from establishing. Accordingly, in all instances the term "*treatment*" may be replaced with the term "*prevention*".

A "*therapeutically effective amount*" refers to an amount effective, at dosages and for periods of time necessary, to achieve the desired therapeutic result, such as raising the level
30 of functional GCCase in a subject (so as to lead to functional GCCase production at a level sufficient to ameliorate the symptoms of GD, for example GD type I).

- Optionally, the vector/viral particle is administered at a dose of less than 1×10^{11} , less than 1×10^{12} , less than 5×10^{12} , less than 2×10^{12} , less than 1.5×10^{12} , less than 3×10^{12} , less than 1×10^{13} , less than 2×10^{13} , or less than 3×10^{13} vector genomes per kg of weight of patient. Optionally, the dose of vector/viral particle that is administered is selected such that the subject expresses GCCase at an level of 10%-90%, 20%-80%, 30%-70%, 25%-50%, 20%-150%, 30%-140%, 40%-130%, 50%-120%, 60%-110% or 70%-100% of the level of a healthy subject who does not suffer from GD.
- 10 Optionally, a patient administered the polynucleotide, viral particle or composition may have a GCCase activity level of at least 1, at least 2, at least 3, at least 4, at least 5, at least 6, at least 7, at least 8, or at least 9 $\mu\text{mol/h/ml}$. Optionally, the GCCase activity is measured using a fluorometric substrate which is specific for GCCase. Optionally, the GCCase activity is measured fluorometrically with 4-Methylumbelliferyl- β -D-glucopyranoside (4MU-Glc) as a substrate. Optionally, the GCCase activity is measured in the serum, plasma, 15 macrophages, spleen, liver and/or bone marrow of the subject.

In one embodiment, GCCase activity may be determined fluorometrically with 4-Methylumbelliferyl- β -D-glucopyranoside (4MU-Glc) as a substrate as follows: (1) serum 20 samples are collected or tissues (liver, spleen, bone marrow) are harvested and snap frozen and lysed; (2) the tissue lysate or serum/plasma sample are mixed in 50 mM Sodium Citrate, 25 mM Taurocholate, pH=5.75, 6 mM 4MU-Glc, for 30 min at 37°C; (3) the reaction is stopped by adding one volume (100 μl) of stop solution (0.5 M Glycine, 0.3 M NaOH, pH 10.0); (4) relative fluorescence levels (RFU) are evaluated with a Spectramax 25 I3X (Molecular devices) using excitation and emission wavelengths of 365 nm and 445 nm, respectively and fluorescence levels were then converted to nanomoles/h/mL based on a 4-Methylumbelliferone (4-MU, Sigma-Aldrich) standard curve.

- Optionally, a patient administered the polynucleotide, viral particle or composition may 30 have a greater GCCase activity level at least 5, at least 10, at least 15, at least 20, at least 25, at least 30, or at least 35 weeks after administration when compared to the activity

- measured in a subject administered an effective dose of a GCCase enzyme replacement therapy, when measured in the same assay at the same time point after administration. Optionally, a patient administered the polynucleotide, viral particle or composition may have a GCCase activity level greater by 10 fold, 20 fold, 50 fold, 100 fold or 1000 fold at least 5, at least 10, at least 15, at least 20, at least 25, at least 30, or at least 35 weeks after administration when compared to the activity measured in a subject administered an effective dose of a GCCase enzyme replacement therapy, when measured in the same assay at the same time point after administration.
- 10 Optionally, the dose of vector/viral particle that is administered is selected such that there is a greater GCCase bioavailability to the subject when compared to the bioavailability from GCCase enzyme replacement therapy. Bioavailability may be measured (*e.g.* estimated or calculated) through any known method in the art. GCCase bioavailability may be measured in the serum, macrophages, spleen, liver and/or bone marrow of the subject. In one
- 15 example, bioavailability may be estimated using the area under the curve (“AUC”) method according to Example 8. In one example, bioavailability may be estimated by estimating the total GCCase activity available in the serum, plasma, macrophages, spleen, liver and/or bone marrow of the subject. Optionally, it is calculated over a defined time period, and refers to the total activity or concentration of GCCase during that time period. Optionally,
- 20 the GCCase activity is measured using a fluorometric substrate which is specific for GCCase. Optionally, the GCCase activity is measured fluorometrically with 4-Methylumbelliferyl- β -D-glucopyranoside (4MU-Glc) as a substrate. Optionally, the GCCase activity is measured in the serum, plasma, macrophages, spleen, liver and/or bone marrow of the subject. Optionally the GCCase activity is measured in the white blood cells of the subject.
- 25 Optionally, the bioavailability is measured over a period of 2 weeks from administration. Optionally, the bioavailability is measured over a period of 5 weeks from administration. Optionally, the bioavailability is measured in serum. In one example, a greater GCCase bioavailability in the subject is achieved over a period of at least 5, at least 10, at least 15, at least 20, at least 25, at least 30, or at least 35 weeks after administration when compared
- 30 to the bioavailability measured in a subject administered an effective dose of a GCCase

enzyme replacement therapy, when measured in the same assay at the same time point after administration.

Optionally, a patient (for example, a patient suffering from a disease or condition associated with GCase deficiency) administered the polynucleotide, viral particle or composition of the invention may have reduced hexosylceramide and/or hexosylsphingosine levels after administration, preferably when the hexosylceramide and/or hexosylsphingosine levels are measured 6 weeks, 8 weeks, 10 weeks or 12 weeks after administration. The hexosylceramide and/or hexosylsphingosine levels may be reduced by 2 times or more, 3 times or more, 4 times or more, 5 times or more, 6 times or more, 2 to 3 times, 2 to 4 times, 2 to 5 times, 2 to 6 times, or 3 to 5 times when compared to the (starting) hexosylceramide and/or hexosylsphingosine levels at the time of administration of the polynucleotide, viral particle or composition of the invention. For example, after administration of the polynucleotide viral particle or composition of the invention (for example 6 weeks, 8 weeks, 10 weeks or 12 weeks after administration), the hexosylceramide and/or hexosylsphingosine levels in the patient may be 50% or less, 40% or less, 30% or less, 25% or less, 20% or less when compared to the (starting) hexosylceramide and/or hexosylsphingosine levels at the time of administration of the polynucleotide, viral particle or composition of the invention. Optionally, the patient may have increased hexosylceramide and/or hexosylsphingosine levels when compared to a healthy subject or a subject who does not have a disease or condition associated with GCase deficiency. For example, the hexosylceramide and/or hexosylsphingosine levels are measured in the spleen, liver and/or bone marrow of the patient/subject. The hexosylceramide and/or hexosylsphingosine levels may be measured in the serum and/or white blood cells (e.g. macrophages) of the patient/subject. Methods of measuring hexosylceramide and/or hexosylsphingosine levels are known in the art, and the levels of hexosylceramide and/or hexosylsphingosine are preferably measured using mass spectrometry (LC/MS analysis), for example by the method described in example 9. Optionally, the reduction of hexosylceramide and/or hexosylsphingosine levels (for example in the serum, white blood cells (e.g. macrophages), spleen, liver and/or bone marrow of the patient/subject) are greater than the reduction achieved from GCase enzyme

replacement therapy, preferably when the hexosylceramide and/or hexosylsphingosine levels are measured after at least 6 weeks, at least 8 weeks, at least 10 weeks or at least 12 weeks after the start of treatment. For example levels after at least 6 weeks (e.g. at 6 weeks), at least 8 weeks (e.g. at 8 weeks), at least 10 weeks (e.g. at 10 weeks) or at least 12 weeks (e.g. at 12 weeks) from administration of the polynucleotide, viral particle or composition of the invention may be compared to levels after at least 6 weeks (e.g. at 6 weeks), at least 8 weeks (e.g. at 8 weeks), at least 10 weeks (e.g. at 10 weeks) or at least 12 weeks (e.g. at 12 weeks), respectively, from the first administration of GCCase enzyme replacement therapy. As a particular example, hexosylceramide and/or

10 hexosylsphingosine levels may be measured after at least 12 weeks (e.g. at 12 weeks) after administration of the polynucleotide, viral particle or composition of the invention and compared to the levels measured at least 12 weeks (e.g. at 12 weeks) after first administration of GCCase enzyme replacement therapy. Preferably, the levels of hexosylceramide and/or hexosylsphingosine are measured in the same assay at the same

15 time point after administration. Optionally, the GCCase enzyme replacement therapy may be administered every two weeks. Optionally, the reduction of hexosylceramide levels in the subject (or patient) after administration of the polynucleotide, viral particle or composition of the invention are such that the hexosylceramide levels (for example in the serum, white blood cells (e.g. macrophages), liver and/or spleen) are no more than 200% ,

20 150%, or 125% of the hexosylceramide levels measured in a healthy subject or a subject not suffering from a disease or condition associated with GCCase deficiency. In one example, a reduction in hexosylceramide and/or hexosylsphingosine levels may represent a reduction in glucosylceramide and/or glucosylsphingosine levels, respectively. For example, a reduction in hexosylceramide may represent a reduction in glucosylceramide.

25 As a further example, a reduction in hexosylsphingosine levels may represent a reduction in glucosylsphingosine levels.

In one example, a reduction in hexosylceramide and/or hexosylsphingosine levels is a reduction in glucosylceramide and/or glucosylsphingosine respectively. In other words, a

30 patient (for example, a patient suffering from a disease or condition associated with GCCase deficiency) administered the polynucleotide, viral particle or composition of the invention

may have reduced glucosylceramide and/or glucosylsphingosine levels after administration, preferably when the glucosylceramide and/or glucosylsphingosine levels are measured 6 weeks, 8 weeks, 10 weeks or 12 weeks after administration. The glucosylceramide and/or glucosylsphingosine levels may be reduced by 2 times or more, 3
5 times or more, 4 times or more, 5 times or more, 6 times or more, 2 to 3 times, 2 to 4 times, 2 to 5 times, 2 to 6 times, or 3 to 5 times when compared to the (starting) glucosylceramide and/or glucosylsphingosine levels at the time of administration of the polynucleotide, viral particle or composition of the invention. For example, after administration of the polynucleotide viral particle or composition of the invention (for example 6 weeks, 8
10 weeks, 10 weeks or 12 weeks after administration), the glucosylceramide and/or glucosylsphingosine levels in the patient may be 50% or less, 40% or less, 30% or less, 25% or less, 20% or less when compared to the (starting) glucosylceramide and/or glucosylsphingosine levels at the time of administration of the polynucleotide, viral particle or composition of the invention. Optionally, the patient may have increased
15 glucosylceramide and/or glucosylsphingosine levels when compared to a healthy subject or a subject who does not have a disease or condition associated with GCase deficiency. For example, the glucosylceramide and/or glucosylsphingosine levels are measured in the spleen, liver and/or bone marrow of the patient/subject. The glucosylceramide and/or glucosylsphingosine levels may be measured in the serum and/or white blood cells (e.g.
20 macrophages) of the patient/subject. Methods of measuring glucosylceramide and/or glucosylsphingosine levels are known in the art, and the levels of glucosylceramide and/or glucosylsphingosine are preferably measured using mass spectrometry (LC/MS analysis), for example by the method described in example 9. Optionally, the reduction of glucosylceramide and/or glucosylsphingosine levels (for example in the serum, white
25 blood cells (e.g. macrophages), spleen, liver and/or bone marrow of the patient/subject) are greater than the reduction achieved from GCase enzyme replacement therapy, preferably when the glucosylceramide and/or glucosylsphingosine levels are measured after at least 6 weeks, at least 8 weeks, at least 10 weeks or at least 12 weeks after the start of treatment. For example levels after at least 6 weeks (e.g. at 6 weeks), at least 8 weeks
30 (e.g. at 8 weeks), at least 10 weeks (e.g. at 10 weeks) or at least 12 weeks (e.g. at 12 weeks) from administration of the polynucleotide, viral particle or composition of the

invention may be compared to levels after at least 6 weeks (e.g. at 6 weeks), at least 8 weeks (e.g. at 8 weeks), at least 10 weeks (e.g. at 10 weeks) or at least 12 weeks (e.g. at 12 weeks), respectively, from the first administration of GCCase enzyme replacement therapy. As a particular example, glucosylceramide and/or glucosylsphingosine levels may be measured after at least 12 weeks (e.g. at 12 weeks) after administration of the polynucleotide, viral particle or composition of the invention and compared to the levels measured at least 12 weeks (e.g. at 12 weeks) after first administration of GCCase enzyme replacement therapy. Preferably, the levels of glucosylceramide and/or glucosylsphingosine are measured in the same assay at the same time point after administration. Optionally, the GCCase enzyme replacement therapy may be administered every two weeks. Optionally, the reduction of glucosylceramide levels in the subject (or patient) after administration of the polynucleotide, viral particle or composition of the invention are such that the glucosylceramide levels (for example in the serum, white blood cells (e.g. macrophages), liver and/or spleen) are no more than 200% , 150%, or 125% of the glucosylceramide levels measured in a healthy subject or a subject not suffering from a disease or condition associated with GCCase deficiency.

Optionally a patient (for example, a patient suffering from a disease or condition associated with GCCase deficiency) administered the polynucleotide, viral particle or composition of the invention may show a reduced number of storage cells and/or activated macrophages in the liver after administration, preferably when the cells are counted after at least 6 weeks (e.g. at 6 weeks), at least 8 weeks (e.g. at 8 weeks), at least 10 weeks (e.g. at 10 weeks) or at least 12 weeks (e.g. at 12 weeks) after administration. Reduction in the number of storage cells and/or activated macrophages in the liver may be an indication of reduced inflammation and thus therapeutic benefit. The number of activated macrophages may be indicated or estimated by measuring the number of CD68^{positive} cells. Identifying storage cells and CD68^{positive} cells can be performed by methods known in the art, for example the methods described in example 9.

A “GCCase enzyme replacement therapy” may refer to any therapy which comprises the administration of a GCCase polypeptide to a subject. The GCCase polypeptide may be wild

type, such as a GCCase polypeptide having the amino acid sequence of SEQ ID NO: 25.

The GCCase polypeptide may be administered at any suitable dose, optionally at a dose of between 40 and 100, between 50 and 80, between 60 and 70, or around 60 U/kg BW. The GCCase polypeptide may be administered through any appropriate route, optionally
5 administered through intravenous injection or subcutaneous injection.

A GCCase activity level of at least X% (e.g. at least 20%) refers to a GCCase activity level that is at least X% (e.g. 20%) of the normal GCCase level range as measured from a sample of e.g. the spleen or bone marrow. The person skilled in the art would readily understand
10 what is meant by reference to a %-of-normal GCCase activity level, which is determined in routine clinical practice by e.g. comparison to a control sample from a healthy subject.

The term “*stable GCCase activity*” or “*stable GCCase activity level*” refers to a GCCase activity level that maintains at or above a certain level for a continuous period of at least 5
15 weeks. In other words, the activity may fluctuate above said activity level but is still said to be stable as long as it remains above the stated minimum threshold. In some embodiments, the GCCase activity level maintains at or above a certain level for a continuous period of at least 10, at least 15, at least 20, at least 30, at least 40, or at least 50 weeks. For example, a patient has a stable GCCase activity level of at least 20% if the
20 activity level maintains at at least 20% for a continuous period of at least 5 weeks. In such an example, the GCCase activity level may continue to be at at least 20% following the at least 5 weeks and thus maintains at at least 20% for a cumulative continuous period of at least 10, at least 15, at least 20, at least 30 or at least 40, or at least 50 weeks. A patient has a stable GCCase activity level if the GCCase activity level maintains at or above a certain
25 level for a continuous period of at least 5 weeks. Optionally, a patient administered with the polynucleotide, viral particle or composition may have a stable GCCase activity level of at least 20%, at least 25%, at least 30%, at least 35%, at least 40% or at least 50% relative to the GCCase activity of a healthy subject. Optionally, a patient administered with the polynucleotide, viral particle or composition may have a stable GCCase activity level of at
30 least 1, at least 2, at least 3, at least 4, at least 5, at least 6, at least 7, at least 8 or at least 9 $\mu\text{mol/h/ml}$. Optionally, the GCCase activity is measured using a fluorometric substrate

which is specific for GCCase. Optionally, the GCCase activity is measured fluorometrically with 4-Methylumbelliferyl- β -D-glucopyranoside (4MU-Glc) as a substrate. Optionally, the GCCase activity is measured in the serum, macrophages, spleen, liver and/or bone marrow of the subject.

5

Optionally, the GCCase activity level is stable after at least 5 weeks, at least 10 weeks, at least 15 weeks, at least 20 weeks, at least 30 weeks, at least 40 weeks, or at least 50 weeks from administration of the polynucleotide, viral particle or composition. For example, where a patient has a stable GCCase activity level of at least 20% after at least 5 weeks from
10 when the patient is administered with the polynucleotide, viral particle or composition, there is a GCCase activity level of at least 20% that maintains at at least 20% for a continuous period of at least 5, at least 10, at least 15, at least 20, at least 30 or at least 40, or at least 50 weeks following the initial at least 5 weeks from administration.

15 Optionally, the GCCase activity level is at or above a certain level (*e.g.* 20%, 25%, 30%, 35%, or 40%; and/or at least 1, at least 2, at least 3, at least 4, at least 5, at least 6, at least 7, at least 8 or at least 9 $\mu\text{mol/h/ml}$) at a time point at least 5, at least 10, at least 20, at least 30, at least 40 or at least 50 weeks after administration of the polynucleotide, viral particle or composition. For example, the GCCase activity level is at or above a certain level (*e.g.*
20 20%, 25%, 30%, 35%, or 40%; and/or at least 1, at least 2, at least 3, at least 4, at least 5, at least 6, at least 7, at least 8 or at least 9 $\mu\text{mol/h/ml}$) at a time point of around 4, 5, 6, 7, 8, 9, 10, 11, 12, 13, 14, 15, 16, 17, 18, 19, 20, 21, 22, 23, 24, 25, 26, 27, 28, 29, 30, 31, 32, 33, 34, 35, 36, 37, 38, 39, 40, 41, 42, 43, 44, 45, 46, 47, 48, 49, 50, 51 or 52 weeks after administration of the polynucleotide, viral particle or composition.

25

The invention will now be described with reference to the following examples, which are merely illustrative and should not in any way be construed as limiting the scope of the present invention.

Sequence Listing

Sequence identity number	Sequence description
1	Codon-optimised GBA nucleotide sequence from FLF-PL28, without signal peptide portion
2	Codon-optimised GBA nucleotide sequence from FLF-PL21, without signal peptide portion
3	Codon-optimised GBA nucleotide sequence from FLF-PL30, without signal peptide portion
4	Codon-optimised GBA nucleotide sequence from FLF-PL36, without signal peptide portion
5	Codon-optimised GBA nucleotide sequence from FLF-PL28, with signal peptide portion
6	Codon-optimised GBA nucleotide sequence from FLF-PL21, with signal peptide portion
7	Codon-optimised GBA nucleotide sequence from FLF-PL30, with signal peptide portion
8	Codon-optimised GBA nucleotide sequence from FLF-PL36, with signal peptide portion
9	Wild type human GBA nucleotide sequence with signal peptide (from GenBank NM_000157.3)
10	LSP-S transcription regulatory element
11	HCR enhancer portion of LSP-S
12	A1AT promoter portion of LSP-S
13	CAG promoter
14	LSP-L transcription regulatory element
15	A1AT promoter portion of LSP-L
16	HCR enhancer portion of LSP-L
17	Wild type GBA nucleotide sequence corresponding to signal peptide
18	Wild type GCCase polypeptide sequence of signal peptide
19	Polypeptide sequence of liver-tropic capsid
20	Polypeptide sequence of liver-tropic capsid
21	Polypeptide sequence of CNS-tropic capsid
22	Nucleotide sequence of SV40 intron
23	Nucleotide sequence of bovine growth hormone poly A sequence
24	Polypeptide sequence of liver-tropic capsid
25	Polypeptide sequence of wild type human GCCase

Aspects of the invention

The invention is further described in the following aspects.

- 5 1. A polynucleotide comprising a GBA nucleotide sequence, wherein the GBA nucleotide sequence encodes a β -Glucocerebrosidase (GCCase) protein or fragment thereof and wherein at least a portion of the GBA nucleotide sequence is not wild type.
- 10 2. The polynucleotide of aspect 1, wherein the portion of the GBA nucleotide sequence that is not wild type is codon-optimised.
3. The polynucleotide of aspect 1 or 2, wherein the GBA nucleotide sequence encodes a GCCase protein or a fragment thereof and comprises a sequence that is at least 95%, at
15 least 96%, at least 97%, at least 98%, at least 99%, at least 99.5%, at least 99.8%, or 100% identical to a nucleotide sequence of any one of SEQ ID NO: 1-8.
4. The polynucleotide of any one of aspects 1 to 3, wherein the GBA nucleotide sequence comprises a sequence of SEQ ID NO: 1 or a variant of SEQ ID NO: 1
20 encoding a GCCase protein having GCCase activity.
5. The polynucleotide of aspect 4, wherein the variant of SEQ ID NO: 1 is identical to SEQ ID NO: 1 except that it comprises nucleotide substitutions such that the GCCase protein has 1, up to 2, up to 3, up to 4, up to 5, up to 6, up to 7, up to 8, up to 9, or up
25 to 10 amino acid substitutions relative to the wild type GCCase amino acid sequence of SEQ ID NO: 25.
6. The polynucleotide of aspect 4 or 5, wherein the variant of SEQ ID NO: 1 has 1, up to 2, up to 3, up to 4, up to 5, up to 6, up to 7, up to 8, up to 9, up to 10, up to 20, or
30 up to 30 nucleotide substitutions relative to the sequence of SEQ ID NO: 1.

7. The polynucleotide of any one of aspects 4 to 6, wherein the variant of SEQ ID NO: 1 has 1, up to 2, up to 3, up to 4, up to 5, or up to 6 nucleotide substitutions relative to the sequence of SEQ ID NO: 1.
- 5 8. The polynucleotide of any one of aspects 4 to 7, wherein the variant of SEQ ID NO: 1 has up to 4 nucleotide substitutions relative to the sequence of SEQ ID NO: 1 and/or encodes a GCCase protein having up to 3 amino acid substitutions relative to the wild type amino acid GCCase sequence of SEQ ID NO: 25.
- 10 9. The polynucleotide of any one of aspects 4 to 8, wherein the variant of SEQ ID NO: 1 has up to 3 nucleotide substitutions relative to the sequence of SEQ ID NO: 1 and/or encodes a GCCase protein having up to 2 amino acid substitutions relative to the wild type GCCase amino acid sequence of SEQ ID NO: 25.
- 15 10. The polynucleotide of any one of aspects 4 to 9, wherein the variant of SEQ ID NO: 1 has 1 nucleotide substitution relative to the sequence of SEQ ID NO: 1 and/or encodes a GCCase protein having up to 1 amino acid substitution relative to the wild type GCCase amino acid sequence of SEQ ID NO: 25.
- 20 11. The polynucleotide of any one of aspects 1 to 3, wherein the GBA nucleotide sequence comprises a sequence of SEQ ID NO: 5 or a variant of SEQ ID NO: 5 encoding a GCCase protein having GCCase activity.
- 25 12. The polynucleotide of aspect 11, wherein the variant of SEQ ID NO: 5 is identical to SEQ ID NO: 5 except that it comprises nucleotide substitutions such that the GCCase protein has 1, up to 2, up to 3, up to 4, up to 5, up to 6, up to 7, up to 8, up to 9, or up to 10 amino acid substitutions relative to the wild type GCCase sequence of SEQ ID NO: 25.

13. The polynucleotide of aspect 11 or 12, wherein the variant of SEQ ID NO: 5 has 1, up to 2, up to 3, up to 4, up to 5, up to 6, up to 7, up to 8, up to 9, up to 10, up to 20, or up to 30 nucleotide substitutions relative to the sequence of SEQ ID NO: 5.
- 5 14. The polynucleotide of any one of aspects 11 to 13, wherein the variant of SEQ ID NO: 5 has 1, up to 2, up to 3, up to 4, up to 5, or up to 6 nucleotide substitutions relative to the sequence of SEQ ID NO: 5.
- 10 15. The polynucleotide of any one of aspects 11 to 14, wherein the variant of SEQ ID NO: 5 has up to 4 nucleotide substitutions relative to the sequence of SEQ ID NO: 5 and/or encodes a GCcase protein having up to 3 amino acid substitutions relative to the wild type GCcase amino acid sequence of SEQ ID NO: 25.
- 15 16. The polynucleotide of any one of aspects 11 to 15, wherein the variant of SEQ ID NO: 5 has up to 3 nucleotide substitutions relative to the sequence of SEQ ID NO: 5 and/or encodes a GCcase protein having up to 2 amino acid substitutions relative to the wild type GCcase amino acid sequence of SEQ ID NO: 25.
- 20 17. The polynucleotide of any one of aspects 11 to 16, wherein the variant has 1 nucleotide substitution relative to the sequence of SEQ ID NO: 5 and/or encodes a GCcase protein having up to 1 amino acid substitution relative to the wild type GCcase amino acid sequence of SEQ ID NO: 25.
- 25 18. The polynucleotide of any one of the preceding aspects, wherein the GBA nucleotide sequence encodes a GCcase protein having 1, up to 2, up to 3, up to 4, or up to 5 amino acid substitutions relative to the wild type GCcase amino acid sequence of SEQ ID NO: 25.
- 30 19. The polynucleotide of any one of the preceding aspects, wherein the GBA nucleotide sequence encodes a GCcase protein having up to 3 amino acid substitutions relative to the wild type GCcase amino acid sequence of SEQ ID NO: 25.

20. The polynucleotide of any one of the preceding aspects, wherein the GBA nucleotide sequence encodes a GCase protein having up to 2 amino acid substitutions relative to the wild type GCase amino acid sequence of SEQ ID NO: 25.
- 5
21. The polynucleotide of any one of the preceding aspects, wherein the GBA nucleotide sequence encodes a variant GCase protein having up to 1 amino acid substitution relative to the wild type GCase amino acid sequence of SEQ ID NO: 25.
- 10
22. A polynucleotide comprising a GBA nucleotide sequence, wherein the GBA nucleotide sequence encodes a GCase protein or a fragment thereof and comprises a sequence that is at least 95%, at least 96%, at least 97%, at least 98%, at least 99%, at least 99.5%, at least 99.8%, or 100% identical to a fragment of at least 1000, at least 1200, at least 1300, less than 1494, less than 1611, between 1000 and 1494, between 15 1000 and 1611, between 1300 and 1494, between 1300 and 1611, around 1494, or around 1611 nucleotides of any one of SEQ ID NO: 1-8.
23. The polynucleotide of any one of the preceding aspects, wherein the GBA nucleotide sequence comprises a sequence that is at least 98% identical to a fragment of at least 20 1300 nucleotides of any one of SEQ ID NO: 1-8.
24. The polynucleotide of any one of the preceding aspects, wherein the GBA nucleotide sequence comprises a sequence that is at least 99% identical to a fragment of at least 1300 nucleotides of any one of SEQ ID NO: 1-8.
- 25
25. The polynucleotide of any one of the preceding aspects, wherein the GBA nucleotide sequence comprises a sequence that is at least 98% identical to a nucleotide sequence of any one of SEQ ID NO: 1-8.

26. The polynucleotide of any one of the preceding aspects, wherein the GBA nucleotide sequence comprises a sequence that is at least 99% identical to a nucleotide sequence of any one of SEQ ID NO: 1-8.
- 5 27. The polynucleotide of any one of the preceding aspects, wherein the GBA nucleotide sequence comprises a sequence that is at least 98% identical to a fragment of at least 1300 nucleotides of SEQ ID NO: 1.
28. The polynucleotide of any one of the preceding aspects, wherein the GBA nucleotide
10 sequence comprises a sequence that is at least 99% identical to a fragment of at least 1300 nucleotides of SEQ ID NO: 1.
29. The polynucleotide of any one of the preceding aspects, wherein the GBA nucleotide sequence comprises a sequence that is at least 98% identical SEQ ID NO: 1.
15
30. The polynucleotide of any one of the preceding aspects, wherein the GBA nucleotide sequence comprises a sequence that is at least 99% identical SEQ ID NO: 1.
31. The polynucleotide of any one of the preceding aspects, wherein the GBA nucleotide
20 sequence comprises a sequence that is at least 98% identical to SEQ ID NO: 5.
32. The polynucleotide of any one of the preceding aspects, wherein the GBA nucleotide sequence comprises a sequence that is at least 99% identical to SEQ ID NO: 5.
- 25 33. The polynucleotide of any one of the preceding aspects, wherein at least a portion of the GBA nucleotide sequence is codon-optimised.
34. The polynucleotide of aspect 33, wherein the portion of the GBA nucleotide
30 sequence that is codon-optimised is codon-optimised for expression in human liver cells.

35. The polynucleotide of aspect 33, wherein the GBA nucleotide sequence is codon-optimised for expression in human liver cells.
36. The polynucleotide of any one of aspects 2 to 35, wherein the portion of the GBA
5 nucleotide sequence that is codon-optimised is a contiguous portion.
37. The polynucleotide of any one of aspects 2 to 36, wherein the portion of the GBA
nucleotide sequence that is codon-optimised is at least 1000, at least 1200, at least
1300, less than 1494, between 1000 and 1494, between 1300 and 1494, or around
10 1494 nucleotides in length.
38. The polynucleotide of any one of aspects 2 to 37, wherein the portion of the GBA
nucleotide sequence that is codon-optimised corresponds to a mature GCcase protein.
- 15 39. The polynucleotide of any one of aspects 2 to 38, wherein the portion of the GBA
nucleotide sequence that is codon-optimised does not encode all or a portion of a
signal peptide.
40. The polynucleotide of any one of aspects 2 to 39, wherein the GBA nucleotide
20 sequence or the portion of the GBA nucleotide sequence that is codon-optimised
comprises a reduced number of CpGs compared to a corresponding portion of a wild
type GBA nucleotide sequence.
41. The polynucleotide of aspect 40, wherein the GBA nucleotide sequence or the
25 portion of the GBA nucleotide sequence that is codon-optimised comprises less than
40, less than 20, less than 18, less than 10, or less than 5 CpGs.
42. The polynucleotide of aspect 41, wherein the GBA nucleotide sequence or the
portion of the GBA nucleotide sequence that is codon-optimised comprises less than
30 5, less than 4, less than 3, or less than 2 CpGs per 100 nucleotides.

43. The polynucleotide of aspect 41 or 42, wherein the GBA nucleotide sequence or the portion of the GBA nucleotide sequence that is codon-optimised is CpG-free.
44. The polynucleotide of any one of aspects 40 to 43, wherein the wild type GBA nucleotide sequence is SEQ ID NO: 9.
45. The polynucleotide of any one of aspects 2 to 44, wherein the portion of the GBA nucleotide sequence that is codon-optimised is at least 80%, at least 85%, at least 90%, at least 95%, at least 98%, at least 99%, at least 99.5%, at least 99.8%, or 100% identical to a fragment of at least 1000, at least 1200, at least 1300, less than 1494, between 1000 and 1494, between 1300 and 1494, or around 1494 nucleotides of any one of SEQ ID NO: 1-4.
46. The polynucleotide of aspect 45, wherein the portion of the GBA nucleotide sequence that is codon-optimised is at least 80%, at least 85%, at least 90%, at least 95%, at least 98%, at least 99%, at least 99.5%, at least 99.8%, or 100% identical to any one of SEQ ID NO: 1-4.
47. The polynucleotide of any one of aspects 2 to 46, wherein the portion of the GBA nucleotide sequence that is codon-optimised is at least 80%, at least 85%, at least 90%, at least 95%, at least 98%, at least 99%, at least 99.5%, at least 99.8%, or 100% identical to a fragment of at least 1000, at least 1200, at least 1300, less than 1494, between 1000 and 1494, between 1300 and 1494, or around 1494 nucleotides of SEQ ID NO: 1.
48. The polynucleotide of aspect 47, wherein the portion of the GBA nucleotide sequence that is codon-optimised is at least 80%, at least 85%, at least 90%, at least 95%, at least 98%, at least 99%, at least 99.5%, at least 99.8%, or 100% identical to SEQ ID NO: 1.

49. The polynucleotide of any one of aspects 2 to 48, wherein the portion of the GBA nucleotide sequence that is codon-optimised is at least 99.5%, at least 99.8%, or 100% identical to a fragment of at least 1300 nucleotides of SEQ ID NO: 1.
- 5 50. The polynucleotide of aspect 49, wherein the portion of the GBA nucleotide sequence that is codon-optimised is at least 99%, at least 99.5%, at least 99.8%, or 100% identical to SEQ ID NO: 1.
- 10 51. The polynucleotide of any one of the preceding aspects, wherein the GBA nucleotide sequence comprises a portion that is not codon-optimised.
52. The polynucleotide of aspect 51, wherein the portion that is not codon-optimised encodes all or a portion of a GCase signal peptide.
- 15 53. The polynucleotide of aspect 51 or 52, wherein the portion that is not codon-optimised is at least 80, at least 90, at least 100, at least 110, less than 200, less than 170, less than 140, or around 117 nucleotides.
- 20 54. The polynucleotide of any one of aspects 51 to 53, wherein the portion that is not codon-optimised comprises 1 or more CpGs.
55. The polynucleotide of any one of the preceding aspects, wherein the polynucleotide further comprises a transcription regulatory element.
- 25 56. The polynucleotide of aspect 55, wherein the transcription regulatory element comprises a liver-specific promoter.
57. The polynucleotide of aspect 55 or 56, wherein the transcription regulatory element comprises an A1AT promoter or a fragment of an A1AT promoter.

30

58. The polynucleotide of aspect 57, wherein the fragment of an A1AT promoter is at least 100, at least 120, at least 150, at least 180, less than 255, between 100 and 255, between 150 and 225, between 150 and 300, or between 180 and 255 nucleotides in length.
- 5
59. The polynucleotide of aspect 58, wherein the fragment of an A1AT promoter is between 180 and 255 nucleotides in length.
60. The polynucleotide of any one of the preceding aspects, wherein the polynucleotide comprises a promoter that is at least 80%, at least 85%, at least 90%, at least 95%, at least 98%, at least 99%, at least 99.5%, at least 99.8%, or 100% identical to SEQ ID NO: 12 or SEQ ID NO: 15.
- 10
61. The polynucleotide of aspect 60, wherein the polynucleotide comprises a promoter that is at least 98%, at least 99%, at least 99.5%, at least 99.8%, or 100% identical to SEQ ID NO. 12 or SEQ ID NO: 15.
- 15
62. The polynucleotide of aspect 61, wherein the polynucleotide comprises a promoter of SEQ ID NO. 12 or SEQ ID NO: 15.
- 20
63. The polynucleotide of any one of aspects 55 to 62, wherein the transcription regulatory element comprises a fragment of an A1AT promoter that is equal to or less than 418 nucleotides, equal to or less than 255 nucleotides, or equal to or less than 185 nucleotides in length and comprises SEQ ID NO: 12.
- 25
64. The polynucleotide of any one of aspects 55 to 63, wherein the transcription regulatory element comprises an enhancer.
65. The polynucleotide of aspect 64, wherein the enhancer is an HCR enhancer or a fragment of an HCR enhancer.
- 30

66. The polynucleotide of aspect 65, wherein the fragment of an HCR enhancer is a fragment of at least 80, at least 90, at least 100, less than 192, between 80 and 192, between 90 and 192, between 100 and 250, or between 117 and 192 nucleotides in length.
- 5
67. The polynucleotide of aspect 66, wherein the fragment of an HCR enhancer is between 117 and 192 nucleotides in length.
68. The polynucleotide of any one of the preceding aspects, wherein the polynucleotide comprises an enhancer that is at least 80%, at least 85%, at least 90%, at least 95% at
10 least 98%, at least 99%, at least 99.5%, at least 99.8%, or 100% identical to SEQ ID NO: 11 or SEQ ID NO: 16.
69. The polynucleotide of aspect 68, wherein the polynucleotide comprises an enhancer
15 that is at least 98%, at least 99%, at least 99.5%, at least 99.8%, or 100% identical to SEQ ID NO: 11 or SEQ ID NO: 16.
70. The polynucleotide of aspect 69, wherein the polynucleotide comprises an enhancer
20 of SEQ ID NO: 11 or SEQ ID NO: 16.
71. The polynucleotide of any one of aspects 55 to 70, wherein the transcription regulatory element comprises a fragment of an HCR enhancer that is equal to or less than 321 nucleotides, equal to or less than 192 nucleotides or equal to or less than 117 nucleotides in length and comprises SEQ ID NO: 11.
- 25
72. The polynucleotide of any one of aspects 55 to 71, wherein the transcription regulatory element is at least 80%, at least 85%, at least 90%, at least 95%, at least 98%, at least 99%, at least 99.5%, at least 99.8%, or 100% identical to SEQ ID NO:
30 10.

73. The polynucleotide of aspect 72, wherein the transcription regulatory element has a sequence of SEQ ID NO: 10.
74. The polynucleotide of any one of the preceding aspects, wherein:
- 5 (i) the GBA nucleotide sequence comprises a sequence that is at least 95%, at least 98%, at least 99%, at least 99.5%, at least 99.8%, or 100% identical to SEQ ID NOs: 1 or 5; and
- (ii) the polynucleotide comprises a promoter that is at least 98%, at least 99%, at least 99.5%, at least 99.8%, or 100% identical to SEQ ID NO. 12 and/or an
10 enhancer element that is at least 98%, at least 99%, at least 99.5%, at least 99.8% or 100% identical to SEQ ID NO: 11.
75. The polynucleotide of any one of the preceding aspects, wherein:
- (i) the GBA nucleotide sequence comprises a sequence that is at least
15 95%, at least 98%, at least 99%, at least 99.5%, at least 99.8%, or 100% identical to SEQ ID NOs: 1 or 5; and
- (ii) the polynucleotide comprises a transcription regulatory element that
is at least 98%, at least 99%, at least 99.5%, at least 99.8%, or 100% identical to
SEQ ID NO. 10.
20
76. The polynucleotide of aspect 57, wherein the A1AT promoter or fragment of an A1AT promoter is at least 200, at least 250, at least 300, less than 500, between 200 and 500, between 250 and 500, between 350 and 450, or around 418 nucleotides in length.
25
77. The polynucleotide of aspect 76, wherein the A1AT promoter or fragment of an A1AT promoter is between 350 and 450 nucleotides in length.
78. The polynucleotide of aspect 65, wherein the HCR enhancer or fragment of an HCR
30 enhancer is a fragment of at least 150, at least 190, at least 230, less than 400,

between 150 and 400, between 190 and 370, between 230 and 340, between 250 and 340, or around 321 nucleotides in length.

- 5 79. The polynucleotide of aspect 78, wherein the HCR enhancer or fragment of an HCR enhancer is between 250 and 340 nucleotides in length.
- 10 80. The polynucleotide of any one of aspects 55 to 79, wherein the transcription regulatory element is at least 80%, at least 85%, at least 90%, at least 95%, at least 98%, at least 99%, at least 99.5%, at least 99.8%, or 100% identical to SEQ ID NO: 14.
- 15 81. The polynucleotide of aspect 80, wherein the transcription regulatory element has a sequence of SEQ ID NO: 14.
- 15 82. The polynucleotide of any one of aspects 1 to 56 or 76 to 79, wherein:
(i) the GBA nucleotide sequence comprises a sequence that is at least 95%, at least 98%, at least 99%, at least 99.5%, at least 99.8%, or 100% identical to SEQ ID NOs: 1 or 5; and
(iii) the polynucleotide comprises a transcription regulatory element that
20 is at least 98%, at least 99%, at least 99.5%, at least 99.8%, or 100% identical to SEQ ID NO: 14.
- 25 83. The polynucleotide of any one of aspects 1 to 56 or 76 to 79, wherein:
(i) the GBA nucleotide sequence comprises a sequence that is at least 95%, at least 98%, at least 99%, at least 99.5%, at least 99.8%, or 100% identical to SEQ ID NOs: 1 or 5; and
(ii) the polynucleotide comprises a promoter that is at least 98%, at least 99%, at least 99.5%, at least 99.8%, or 100% identical to SEQ ID NO. 15 and/or an enhancer element that is at least 98%, at least 99%, at least 99.5%, at least 99.8% or
30 100% identical to SEQ ID NO: 16.

84. The polynucleotide of any one of the preceding aspects, wherein the GCcase encoded by the GBA nucleotide sequence is expressed in human liver cells at higher levels compared to a GCcase encoded by a wild type GBA nucleotide sequence in an otherwise identical reference polynucleotide.
- 5
85. The polynucleotide of any one of the preceding aspects, wherein the GCcase encoded by the GBA nucleotide sequence is expressed in human liver cells at least 1.1x, at least 1.2x, at least 1.3x, at least 1.4x, or at least 1.5x higher compared to a GCcase encoded by a wild type GBA nucleotide sequence in a reference polynucleotide.
- 10
86. The polynucleotide of aspect 84 or 85, wherein the reference polynucleotide comprises a wild type GBA nucleotide sequence of SEQ ID NO: 9.
87. The polynucleotide of aspect 86, wherein the reference polynucleotide comprises a promoter of SEQ ID NO: 13.
- 15
88. The polynucleotide of any one of the preceding aspects, wherein the GCcase encoded by the GBA nucleotide sequence is expressed in human liver cells at higher or non-statistically significant different levels compared to GCcase encoded by an otherwise identical reference polynucleotide comprising a GBA nucleotide sequence of SEQ ID NO: 9 and operably linked to a promoter of SEQ ID NO: 13.
- 20
89. The polynucleotide of any one of the preceding aspects, wherein the polynucleotide comprises DNA or RNA.
- 25
90. A viral particle comprising a recombinant genome comprising the polynucleotide of any one of the preceding aspects.
91. The viral particle of aspect 90, which is an AAV, adenoviral, or lentiviral viral particle.
- 30

92. The viral particle of aspect 91, which is an AAV viral particle.
93. The viral particle of any one of aspects 90 to 92, wherein the viral particle comprises a liver-tropic or CNS-tropic capsid.
- 5
94. The viral particle of aspect 93, wherein the liver-tropic capsid comprises a sequence at least 98%, at least 99%, or at least 99.5% identical to a fragment of at least 600, at least 650, at least 700, between 600 and 736, between 650 and 736, or between 700 and 736 amino acids of SEQ ID NO: 19 or 20.
- 10
95. The viral particle of aspect 94, wherein the liver-tropic capsid comprises a sequence at least 99% identical to SEQ ID NO: 19.
96. The viral particle of aspect 94, wherein the liver-tropic capsid comprises a sequence
- 15 at least 99% identical to SEQ ID NO: 20.
97. The viral particle of aspect 93, wherein the CNS-tropic capsid comprises a sequence at least 98%, at least 99%, or at least 99.5% identical to a fragment of at least 600, at least 650, at least 700, between 600 and 736, between 650 and 736 or between 700
- 20 and 736 amino acids of SEQ ID NO: 21.
98. The viral particle of aspect 97, wherein the CNS-tropic capsid comprises a sequence at least 99% identical to SEQ ID NO: 21.
- 25 99. The viral particle of any one of aspects 90 to 98, wherein the recombinant genome further comprises:
- a) AAV2 ITRs;
 - b) a poly A sequence; and/or
 - c) an intron.
- 30
100. The viral particle of aspect 99, wherein the recombinant genome is single-stranded.

101. The viral particle of any one of aspects 90 to 100, wherein on transduction into Huh-7 cells, the viral particle expresses GCCase or a fragment thereof such that the GCCase activity in the transduced cell is greater than the activity of GCCase or a fragment thereof in a cell transduced with an otherwise identical viral particle comprising a GBA nucleotide sequence of SEQ ID NO: 9.
102. The viral particle of any one of aspects 90 to 101, wherein on transduction into Huh-7 cells, the viral particle expresses GCCase or a fragment thereof such that the GCCase activity in the transduced cell is at least 2x, at least 3x, at least 4x, at least 5x, at least 10x, or at least 20x greater than the activity of GCCase or a fragment thereof in a cell transduced with an otherwise identical viral particle comprising a GBA nucleotide sequence of SEQ ID NO: 9.
103. The viral particle of aspect 101 or 102, wherein the activity is measured using a fluorometric substrate which is specific for GCCase.
104. A composition comprising the polynucleotide or viral particle of any one of the preceding aspects and a pharmaceutically acceptable excipient.
105. The polynucleotide, viral particle or composition of any one of the preceding aspects for use in a method of treatment.
106. The polynucleotide, viral particle or composition for use of aspect 105, wherein the method of treatment comprises administering an effective amount of the polynucleotide, composition or viral particle of any one of aspects 1 to 104 to a patient.
107. A method of treatment comprising administering an effective amount of the polynucleotide, composition or viral particle of any one of aspects 1 to 104 to a patient.

108. Use of the polynucleotide, viral particle or composition of any one of aspects 1 to 104 in the manufacture of a medicament for use in a method of treatment.
109. The use of aspect 108, wherein the method of treatment comprises administering an effective amount of the polynucleotide or viral particle of any one of aspects 1 to 104 to a patient.
110. The polynucleotide, viral particle, composition, use or method of any one of aspects 105 to 109, wherein the method of treatment is a method of treating a disease associated with GCase deficiency.
111. The polynucleotide, viral particle, composition, use or method of any one of aspects 105 to 109, wherein the method of treatment is a method of treating Parkinson's disease.
112. The polynucleotide, viral particle, composition, use or method of any one of aspects 105 to 109, wherein the method of treatment is a method of treating Gaucher disease.
113. The polynucleotide, viral particle, composition, use or method of aspect 112, wherein the Gaucher disease is Gaucher disease type I.
114. The polynucleotide, viral particle, composition, use or method of aspect 112, wherein the Gaucher disease is Gaucher disease type II.
115. The polynucleotide, viral particle, composition, use or method of aspect 112, wherein the Gaucher disease is Gaucher disease type III.
116. The polynucleotide, viral particle, composition, use or method of any one of aspects 112 to 115, wherein the patient has antibodies or inhibitors to a recombinant GCase with which the patient has previously been treated as part of an enzyme replacement therapy.

117. Use of the polynucleotide, viral particle or composition of any one of aspects 1 to 104 in the manufacture of a medicament for achieving a stable GCCase activity in a subject.
- 5
118. Use of the polynucleotide, viral particle or composition of any one of aspects 1 to 104 in the manufacture of a medicament for providing greater GCCase bioavailability in a subject compared to the bioavailability from GCCase enzyme replacement therapy, wherein the bioavailability is measured over a period of 2 weeks from administration.
- 10
119. A method of achieving a stable GCCase activity in a subject by administering to the subject the polynucleotide, viral particle or composition of any one of aspects 1 to 104.
- 15
120. A method of providing greater GCCase bioavailability in a subject compared to the bioavailability from GCCase enzyme replacement therapy by administering to the subject the polynucleotide, viral particle or composition of any one of aspects 1 to 104, wherein the bioavailability is measured over a period of 2 weeks from administration.
- 20
121. The method or use of any one of aspects 117 to 120, wherein achieving a stable GCCase activity in a subject or providing greater GCCase bioavailability in a subject treats a disease in the subject.
- 25
122. The polynucleotide, viral particle or composition of any one of aspects 1 to 104, for use in a method of expressing the GBA nucleotide sequence and achieving a stable GCCase activity in a subject.
- 30
123. The polynucleotide, viral particle or composition of any one of aspects 1 to 104, for use in a method of expressing the GBA nucleotide sequence and providing greater

GCCase bioavailability in a subject compared to the bioavailability from GCCase enzyme replacement therapy, wherein the bioavailability is measured over a period of 2 weeks from administration.

- 5 124. The polynucleotide, viral particle or composition for use of aspect 122 or 123, wherein achieving a stable GCCase activity and/or providing greater GCCase bioavailability leads to the treatment of a disease in the subject.
- 10 125. The polynucleotide, viral particle or composition for use, use or method of any one of aspects 117 to 124, wherein the GCCase activity and/or bioavailability is measured using a fluorometric substrate which is specific for GCCase.
- 15 126. The polynucleotide, viral particle or composition for use, use or method of any one of aspects 117 to 125, wherein the GCCase activity is measured in the serum or plasma of the subject.
- 20 127. The polynucleotide, viral particle or composition for use, use or method of any one of aspects 117 to 126, wherein the GCCase activity is measured in the macrophages of the subject.
- 25 128. The polynucleotide, viral particle or composition for use, use or method of any one of aspects 117 to 127, wherein the GCCase activity is stable at a level of at least 1, at least 2, at least 3, at least 4, at least 5, at least 6, at least 7, at least 8, or at least 9 $\mu\text{mol/h/ml}$ in the subject.
129. The polynucleotide, viral particle or composition for use, use or method of any one of aspects 117 to 128, wherein the GCCase activity is stable at a level of at least 3 $\mu\text{mol/h/ml}$ in the subject.

130. The polynucleotide, viral particle or composition for use, use or method of any one of aspects 117 to 129, wherein the GCCase activity is stable at a level of at least 5 $\mu\text{mol/h/ml}$ in the subject.
- 5 131. The polynucleotide, viral particle or composition for use, use or method of any one of aspects 117 to 130, wherein the GCCase activity is stable at a level of at least 9 $\mu\text{mol/h/ml}$ in the subject.
- 10 132. The polynucleotide, viral particle or composition for use, use or method of any one of aspects 117 to 131, wherein the method comprises administering an effective dose of the polynucleotide, viral particle or composition to the subject.
- 15 133. The polynucleotide, viral particle or composition for use, use or method of any one of aspects 117 to 132, wherein the stable GCCase activity is a GCCase activity of at least 10%, at least 20%, at least 30%, at least 40%, or at least 50% relative to the GCCase activity of a healthy subject.
- 20 134. The polynucleotide, viral particle or composition for use, use or method of any one of aspects 117 to 133, wherein the stable GCCase activity is a GCCase activity of between 10% and 100%, between 20% and 90%, between 30% and 70%, between 40% and 70%, or between 50% and 70% relative to the GCCase activity of a healthy subject.
- 25 135. The polynucleotide, viral particle or composition for use, use or method of any one of aspects 117 to 134, wherein the stable GCCase activity is stable for at least 5 weeks from administration.
- 30 136. The polynucleotide, viral particle or composition for use, use or method of any one of aspects 117 to 135, wherein the stable GCCase activity is stable for at least 10 weeks from administration.

137. The polynucleotide, viral particle or composition for use, use or method of any one of aspects 117 to 136, wherein the stable GCCase activity is stable for at least 15 weeks from administration.
- 5 138. The polynucleotide, viral particle or composition for use, use or method of any one of aspects 117 to 137, wherein the stable GCCase activity is stable for at least 20 weeks from administration.
- 10 139. The polynucleotide, viral particle or composition for use, use or method of any one of aspects 117 to 138, wherein the stable GCCase activity is stable for at least 25 weeks from administration.
- 15 140. The polynucleotide, viral particle or composition for use, use or method of any one of aspects 117 to 139, wherein the stable GCCase activity is stable for at least 30 weeks from administration.
- 20 141. The polynucleotide, viral particle or composition for use, use or method of any one of aspects 117 to 140, wherein the stable GCCase activity is stable for at least 35 weeks from administration.
- 25 142. The polynucleotide, viral particle or composition for use, use or method of any one of aspects 117 to 141, wherein the stable GCCase activity is stable for at least 40 weeks after administration.
- 30 143. The polynucleotide, viral particle or composition for use, use or method of any one of aspects 117 to 142, wherein the method achieves a greater GCCase activity in the liver, spleen, and/or bone marrow of the subject at least 5, at least 10, at least 15, at least 20, at least 25, at least 30, or at least 35 weeks after administration when compared to the activity measured in a subject administered an effective dose of a GCCase enzyme replacement therapy, when measured in the same assay at the same time point after administration.

144. The polynucleotide, viral particle or composition for use, use or method of any one of aspects 117 to 143, wherein the method achieves a greater GCCase bioavailability in the liver spleen and/or bone marrow subject over a period of at least 5, at least 10,
5 at least 15, at least 20, at least 25, at least 30, or at least 35 weeks after administration when compared to the bioavailability measured in a subject administered an effective dose of a GCCase enzyme replacement therapy, when measured in the same assay at the same time point after administration.
- 10 145. The polynucleotide, viral particle or composition for use, use or method of any one of aspects 118, 120 or 123 to 144, wherein the GCCase enzyme replacement therapy comprises administration of a GCCase polypeptide having the sequence of SEQ ID NO: 25.
- 15 146. The polynucleotide, viral particle or composition for use, use or method of aspect 145, wherein the GCCase enzyme replacement therapy comprises administration of the GCCase polypeptide at a dose of between 40 and 100, between 50 and 80, between 60 and 70, or around 60 U/kg BW.
- 20 147. The polynucleotide, viral particle or composition for use, use or method of any one of aspects 121 or 124 to 146, wherein the disease is Gaucher disease.
148. The polynucleotide, viral particle or composition for use, use or method of aspect
25 147, wherein the Gaucher disease is Gaucher disease type I.
149. The polynucleotide, viral particle or composition for use, use or method of aspect
147, wherein the Gaucher disease is Gaucher disease type II.
150. The polynucleotide, viral particle or composition for use, use or method of aspect
30 147, wherein the Gaucher disease is Gaucher disease type III.

151. The polynucleotide, viral particle or composition for use, use or method of any one of aspects 117 to 150, wherein the patient has antibodies or inhibitors to a recombinant GCCase with which the patient has previously been treated as part of an enzyme replacement therapy.
- 5
152. Use of the polynucleotide, viral particle or composition of any one of aspects 1 to 104 in the manufacture of a medicament for reducing the levels of hexosylceramide and/or hexosylsphingosine in a subject suffering from a disease or condition associated with GCCase deficiency.
- 10
153. A method of reducing the levels of hexosylceramide and/or hexosylsphingosine in a subject suffering from a disease or condition associated with GCCase deficiency by administering to the subject the polynucleotide, viral particle or composition of any one of aspects 1 to 104.
- 15
154. The use or method of aspect 152 or 153 wherein reducing the levels of hexosylceramide and/or hexosylsphingosine in a subject treats the disease or condition associated with GCCase deficiency.
- 20
155. The polynucleotide, viral particle or composition of any one of aspects 1 to 104, for use in a method of reducing hexosylceramide and/or hexosylsphingosine levels in a subject suffering from a disease or condition associated with GCCase deficiency, optionally wherein reducing hexosylceramide and/or hexosylsphingosine levels leads to the treatment of the disease or condition associated with GCCase deficiency.
- 25
156. The polynucleotide, viral particle or composition for use, use or method of any one of aspects 152 to 155, wherein the hexosylceramide and/or hexosylsphingosine levels are reduced by 2 times or more, 3 times or more, 4 times or more, 5 times or more, 6 times or more, 2 to 3 times, 2 to 4 times, 2 to 5 times, 2 to 6 times, or 3 to 5 times
- 30
- when compared to the hexosylceramide and/or hexosylsphingosine levels at the time

of administration of the polynucleotide, viral particle or composition of any one of aspects 1 to 104.

- 5 157. The polynucleotide, viral particle or composition for use, use or method of any one of aspects 152 to 156, wherein the reduction in hexosylceramide and/or hexosylsphingosine levels is greater than the reduction achieved in a subject administered an effective dose of a GCCase enzyme replacement therapy, optionally when the hexosylceramide and/or hexosylsphingosine levels are measured at least 6 weeks, at least 8 weeks, at least 10 weeks or at least 12 weeks after administration.
- 10 158. The polynucleotide, viral particle or composition for use, use or method of aspect 157, wherein the GCCase enzyme replacement therapy comprises administration of a GCCase polypeptide having the sequence of SEQ ID NO: 25.
- 15 159. The polynucleotide, viral particle or composition for use, use or method of aspect 158, wherein the GCCase enzyme replacement therapy comprises administration of the GCCase polypeptide at a dose of between 40 and 100, between 50 and 80, between 60 and 70, or around 60 U/kg BW.
- 20 160. The polynucleotide, viral particle or composition for use, use or method of any one of aspects 152 to 159, wherein the hexosylceramide and/or hexosylsphingosine levels are measured in the macrophages of the subject.
- 25 161. The polynucleotide, viral particle or composition for use, use or method of any one of aspects 152 to 160, wherein the hexosylceramide and/or hexosylsphingosine levels are measured in the spleen of the subject.
- 30 162. The polynucleotide, viral particle or composition for use, use or method of any one of aspects 152 to 161, wherein the hexosylceramide and/or hexosylsphingosine levels are measured in the liver of the subject.

163. The polynucleotide, viral particle or composition for use, use or method of any one of aspects 152 to 162, wherein the hexosylceramide and/or hexosylsphingosine levels are measured in the serum of the subject.
- 5 164. The polynucleotide, viral particle or composition for use, use or method of any one of aspects 152 to 163, wherein the hexosylceramide and/or hexosylsphingosine levels are measured by mass spectrometry.
- 165 The polynucleotide, viral particle or composition for use, use or method of any one
10 of aspects 152 to 164, wherein the disease is Gaucher disease.
166. The polynucleotide, viral particle or composition for use, use or method of aspect 165, wherein the Gaucher disease is Gaucher disease type I.
- 15 167. The polynucleotide, viral particle or composition for use, use or method of aspect 165, wherein the Gaucher disease is Gaucher disease type II.
168. The polynucleotide, viral particle or composition for use, use or method of aspect
20 165, wherein the Gaucher disease is Gaucher disease type III.
169. The polynucleotide, viral particle or composition for use, use or method of any one of aspects 152 to 168, wherein the patient has antibodies or inhibitors to a recombinant GCase with which the patient has previously been treated as part of an enzyme replacement therapy.

25

Further aspects of the invention

The invention is also described in the following aspects.

5

1. A polynucleotide comprising a GBA nucleotide sequence, wherein the GBA nucleotide sequence encodes a β -Glucocerebrosidase (GCase) protein or fragment thereof and wherein at least a portion of the GBA nucleotide sequence is not wild type, optionally wherein the portion of the GBA nucleotide sequence that is not wild type is codon-optimised, more optionally wherein the GBA nucleotide sequence encodes a GCase protein or a fragment thereof and comprises a sequence that is at least 95%, at least 96%, at least 97%, at least 98%, at least 99%, at least 99.5%, at least 99.8%, or 100% identical to a nucleotide sequence of any one of SEQ ID NO: 1-8.
10
15
2. A polynucleotide comprising a GBA nucleotide sequence, wherein the GBA nucleotide sequence encodes a GCase protein or a fragment thereof and comprises a sequence that is at least 95%, at least 96%, at least 97%, at least 98%, at least 99%, at least 99.5%, at least 99.8%, or 100% identical to a fragment of at least 1000, at least 1200, at least 1300, less than 1494, less than 1611, between 1000 and 1494, between 1000 and 1600, between 1300 and 1494, between 1300 and 1611, around 1494, or around 1611 nucleotides of any one of SEQ ID NO: 1-8.
20
- 25 3. The polynucleotide of any one of aspects 1 to 2, wherein at least a portion of the GBA nucleotide sequence is codon-optimised.
4. The polynucleotide of aspect 3, wherein:
 - (a) the at least a portion of the GBA nucleotide sequence that is codon-optimised is codon-optimised for expression in human liver cells;
30
 - (b) the portion of the GBA nucleotide sequence that is codon-optimised is a contiguous portion;

- (c) the portion of the GBA nucleotide sequence that is codon-optimised is at least 1000, at least 1200, at least 1300, less than 1494, between 1000 and 1494, between 1300 and 1494, or around 1494 nucleotides in length;
- (d) the portion of the GBA nucleotide sequence that is codon-optimised corresponds to a mature GCCase protein;
- (e) the portion of the GBA nucleotide sequence that is codon-optimised does not encode all or a portion of a signal peptide;
- (f) the GBA nucleotide sequence or the portion of the GBA nucleotide sequence that is codon-optimised comprises a reduced number of CpGs compared to a corresponding portion of a wild type GBA nucleotide sequence; optionally wherein the GBA nucleotide sequence or the portion of the GBA nucleotide sequence that is codon-optimised comprises less than 40, less than 20, less than 18, less than 10, or less than 5 CpGs, more optionally wherein the GBA nucleotide sequence or the portion of the GBA nucleotide sequence that is codon-optimised comprises less than 5, less than 4, less than 3, or less than 2 CpGs per 100 nucleotides, more optionally wherein the GBA nucleotide sequence or the portion of the GBA nucleotide sequence that is codon-optimised is CpG-free, preferably wherein the wild type GBA nucleotide sequence is SEQ ID NO: 9; and/or
- (g) the portion of the GBA nucleotide sequence that is codon-optimised is at least 80%, at least 85%, at least 90%, at least 95%, at least 98%, at least 99%, at least 99.5%, at least 99.8%, or 100% identical to a fragment of at least 1000, at least 1200, at least 1300, less than 1494, between 1000 and 1494, between 1300 and 1494, or around 1494 nucleotides of any one of SEQ ID NO: 1-4.
5. The polynucleotide of any one of the preceding aspects, wherein the GBA nucleotide sequence comprises a portion that is not codon-optimised, optionally wherein:
- (a) the portion that is not codon-optimised encodes all or a portion of a GCCase signal peptide;

- (b) the portion that is not codon-optimised is at least 80, at least 90, at least 100, at least 110, less than 200, less than 170, less than 140, or around 117 nucleotides; and/or
- (c) the portion that is not codon-optimised comprises 1 or more CpGs.
- 5
6. The polynucleotide of any one of the preceding aspects, wherein the polynucleotide further comprises a transcription regulatory element, optionally wherein the transcription regulatory element comprises a liver-specific promoter and/or an enhancer.
- 10
7. The polynucleotide of aspect 6, wherein the transcription regulatory element comprises an A1AT promoter or a fragment of an A1AT promoter, optionally wherein
- (a) the A1AT promoter or the fragment of an A1AT promoter is at least 100, at least 120, at least 150, at least 180, less than 255, between 100 and 255, between 150 and 225, between 150 and 300, or between 180 and 255 nucleotides in length, more optionally wherein the fragment of an A1AT promoter is between 180 and 255 nucleotides in length;
- 15
- (b) the A1AT promoter or the fragment of an A1AT promoter is at least 200, at least 250, at least 300, less than 500, between 200 and 500, between 250 and 500, between 350 and 450, or around 418 nucleotides in length, more optionally wherein the fragment of an A1AT promoter is between 350 and 450 nucleotides in length;
- 20
- (c) the polynucleotide comprises a promoter that is at least 80%, at least 85%, at least 90%, at least 95%, at least 98%, at least 99%, at least 99.5%, at least 99.8%, or 100% identical to SEQ ID NO: 12 or SEQ ID NO: 15.
- 25
8. The polynucleotide of aspects 6 or 7, wherein the enhancer is an HCR enhancer or a fragment of an HCR enhancer, optionally wherein:
- (a) the HCR enhancer or the fragment of an HCR enhancer is a fragment of at least 80, at least 90, at least 100, less than 192, between 80 and 192, between 90 and 192, between 100 and 250, or between 117 and 192 nucleotides in length, more
- 30

- optionally wherein the fragment of an HCR enhancer is between 117 and 192 nucleotides in length;
- (b) the HCR enhancer or the fragment of an HCR enhancer is a fragment of at least 150, at least 190, at least 230, less than 400, between 150 and 400, between 190 and 370, between 230 and 340, between 250 and 340, or around 321 nucleotides in length, more optionally wherein the fragment of an HCR enhancer is between 250 and 340 nucleotides in length
- (c) the polynucleotide comprises an enhancer that is at least 80%, at least 85%, at least 90%, at least 95% at least 98%, at least 99%, at least 99.5%, at least 99.8%, or 100% identical to SEQ ID NO: 11 or SEQ ID NO: 16.
9. The polynucleotide of aspect 6, wherein the transcription regulatory element is at least 80%, at least 85%, at least 90%, at least 95%, at least 98%, at least 99%, at least 99.5%, at least 99.8%, or 100% identical to SEQ ID NO: 10 or 14.
10. The polynucleotide of any one of the preceding aspects, wherein the GCase encoded by the GBA nucleotide sequence is expressed in human liver cells at higher levels compared to a GCase encoded by a wild type GBA nucleotide sequence in an otherwise identical reference polynucleotide, optionally wherein the GCase encoded by the GBA nucleotide sequence is expressed in human liver cells at least 1.1x, at least 1.2x, at least 1.3x, at least 1.4x, or at least 1.5x higher compared to a GCase encoded by a wild type GBA nucleotide sequence in an otherwise identical reference polynucleotide, more optionally wherein the reference polynucleotide comprises a wild type GBA nucleotide sequence of SEQ ID NO: 9, optionally wherein the reference polynucleotide comprises a promoter of SEQ ID NO: 13.
11. A viral particle comprising a recombinant genome comprising the polynucleotide of any one of the preceding aspects.
12. The viral particle of aspect 11, which is an AAV, adenoviral, or lentiviral viral particle, optionally which is an AAV viral particle.

13. The viral particle of any one of aspects 11-12, wherein the viral particle comprises a liver-tropic or CNS-tropic capsid.
- 5 14. The viral particle of aspect 13, wherein the liver-tropic capsid comprises a sequence at least 98%, at least 99%, at least 99.5% to a fragment of at least 600, at least 650, at least 700, between 600 and 736, between 650 and 736 or between 700 and 736 amino acids of SEQ ID NO: 19, 20 or 24.
- 10 15. The viral particle of aspect 13, wherein the CNS-tropic capsid comprises a sequence at least 98%, at least 99%, at least 99.5% to a fragment of at least 600, at least 650, at least 700, between 600 and 736, between 650 and 736 or between 700 and 736 amino acids of SEQ ID NO: 21.
- 15 16. The viral particle of any one of aspects 11 to 15, wherein the recombinant genome further comprises:
- a) AAV2 ITRs;
 - b) a poly A sequence; and/or
 - c) an intron;
- 20 optionally wherein the recombinant genome is single-stranded.
17. The viral particle of any one of aspects 11 to 16, wherein on transduction into Huh-7 cells, the viral particle expresses GCCase or a fragment thereof such that the GCCase activity in the transduced cell is greater than the activity of GCCase or a fragment thereof in a cell transduced with an otherwise identical viral particle comprising a GBA nucleotide sequence of SEQ ID NO: 9, optionally wherein on transduction into Huh-7 cells, the viral particle expresses GCCase or a fragment thereof such that the GCCase activity in the transduced cell is at least 2x, at least 3x, at least 4x, at least 5x, at least 10x, or at least 20x greater than the activity of GCCase or a fragment thereof in a cell transduced with an otherwise identical viral particle comprising a GBA nucleotide sequence of SEQ ID NO: 9, more optionally wherein the activity is measured using a fluorometric substrate which is specific for GCCase.
- 25
- 30

18. A composition comprising the polynucleotide or viral particle of any one of the preceding aspects and a pharmaceutically acceptable excipient.
- 5 19. The polynucleotide, viral particle or composition of any one of the preceding aspects for use in a method of treatment.
20. The polynucleotide, viral particle or composition for use of aspect 19, wherein the method of treatment comprises administering an effective amount of the
10 polynucleotide, composition or viral particle of any one of aspects 1 to 17 to a patient.
21. The polynucleotide, viral particle, or composition for use of any one of aspects 19 to 20, wherein the method of treatment is a method of treating a disease associated with
15 GCase deficiency.
22. The polynucleotide, viral particle, or composition for use of any one of aspects 19 to 20, wherein the method of treatment is a method of treating Parkinson's disease.
- 20 23. The polynucleotide, viral particle, or composition for use of any one of aspects 19 to 20, wherein the method of treatment is a method of treating Gaucher disease.
24. The polynucleotide, viral particle, or composition for use of aspect 23, wherein the Gaucher disease is Gaucher disease type I, II or III.
25
25. The polynucleotide, viral particle, or composition for use of any one of aspects 23 to 24, wherein the patient has antibodies or inhibitors to a recombinant GCase with which the patient has previously been treated as part of an enzyme replacement
30 therapy.

Examples

Example 1 - Methods

- 5 Unless specified otherwise, the following general methods were followed in the examples described below.

rAAV production

- 10 AAV2/8 particles were produced by transient transfection of HEK293T cells with plasmids encoding the AAV Rep and Cap, and adenoviral helper functions, as well the recombinant genome containing the GBA construct. AAV2/8 particles were purified by aPOROS CaptureSelect affinity column and were titered by qPCR and characterised by alkaline gel analysis.

15

Mouse study design

- AAV viral particles carrying the GBA transgene under transcriptional control of the hepatocyte-specific promoters were administered into the tail vein of wild type (C57BL/6)
20 male mice at age of 6-8 weeks. AAV dose ranged from 6×10^{11} vg/kg to 6×10^{12} vg/kg, as herein for each study. For each experiment, an additional group of animals was left untreated to serve as a control for the effects of treatment. To assess the kinetics and durability of transgene expression, serum GCase levels were measured at various time intervals (4-, 8-, and 12- weeks) post injection. Mice were followed up to 12 weeks post
25 AAV treatment and sacrificed for biochemical and pathological analysis.

Serum and tissue GBA activity assay

- β -Glucocerebrosidase (acid β -glucosidase; GCase) activity was determined
30 fluorometrically with 4-Methylumbelliferyl- β -D-glucopyranoside (4MU-Glc) as a substrate. Serum samples were obtained from mouse blood and stored at -80 °C. Tissues

(liver, spleen, bone marrow) were harvested and snap frozen and lysed. β -Glucocerebrosidase (acid β -glucosidase, GCase) activity was determined fluorometrically with 4-Methylumbelliferyl- β -D-glucopyranoside (4MU-Glc) as a substrate. On the day of the assay, serum was diluted (0.5 μ L, 1:50) and assayed in 50 mM Sodium Citrate, 25 mM Taurocholate, pH=5.75, 6 mM 4MU-Glc, for 30 min at 37°C. For tissue samples, the tissue protein lysate was assayed directly. The reaction was stopped by adding one volume (100 μ l) of stop solution (0.5 M Glycine, 0.3 M NaOH, pH 10.0). Relative fluorescence levels (RFU) were evaluated with a Spectramax I3X (Molecular devices) using excitation and emission wavelengths of 365 nm and 445 nm, respectively. Fluorescence levels were then converted to nanomoles/h/mL (serum) or nmol/h/mg of total protein (tissue) based on a 4-Methylumbelliferone (4-MU, Sigma-Aldrich) standard curve.

Vector genome copy number

To determine the number of vector genomes per liver cell post- rAAV injection, DNA was isolated from frozen liver samples using QIAGEN DNeasy Blood and Tissue Kit (QIAGEN) following manufacturers' instructions. Following DNA isolation, qPCR was performed using primer sets which bind to a region common to both LSP-S and LSP-L promoters, allowing estimation of AAV copy number.

20

Immunohistochemistry

Rabbit anti-human GCase (Abcam ab125065; 1:100) was used to visualize GCase in mouse tissue. The rat anti-F4/80 (Abcam ab6640; 1:100) was used to visualize mouse macrophages. The formalin-fixed mouse tissues were deparaffinized with xylene and ethanol washes, followed by antigen retrieval according to Ventana CC1 product use recommendations. Immunohistochemistry staining was performed using the Ventana Discovery XT instrument, using the Ventana DAB Map detection Kit (760-124). Sections were counterstained with haematoxylin. FITC- and Texas red-conjugated secondary antibodies were used during immunofluorescent staining. DAPI was used to visualize nuclei. The signals were visualized by confocal fluorescence microscopy (Zeiss).

30

Huh-7 transfection and potency assay

The day before transfection, the liver hepatocyte cell line Huh-7 was plated in a 12 well
5 plate at the cell density of 3×10^5 cells per well. For transfection, FuGENE was used at the
ratio of 4 μ l per μ g of plasmid and added overnight to Huh-7 cells in the presence of 10%
of serum (foetal bovine serum, FBS). Transfection medium was changed, and cells were
incubated for 24 hours with medium supplemented with Insulin-Transferrin-Selenium
(ITS, ThermoFisher Scientific) and 25 mM Hepes buffer. Huh-7 cell transduction, was
10 performed at defined multiplicity of infection (MOI) in the presence of serum for 24 hours,
followed by a medium change and incubation for 24 hours in fresh medium. 20 μ l of
medium was used to measure GCase activity using 4MU-Glc as a substrate, as described
above.

15 ***Statistical analysis***

Statistical analysis was performed using Prism 7 (Graph Pad) software. Columns analysis
was performed by one-way ANOVA. P-values and sample size are indicated in Figure
descriptions.

20

To approximate bioavailability (AUC), a one-phase decay model equation: $Y = (Y_0 - \text{Plateau}) * \exp(-K * X) + \text{Plateau}$ was used in GraphPad Prism. Y_0 is the Y-value when X
(time) is zero and it is expressed in the same units as Y. Plateau is the Y-value at infinite
times, expressed in the same units as Y. K is the rate constant, expressed in reciprocal of
25 the X-axis time units (i.e. if X is in minutes, then K is expressed in minutes^{-1}). Tau is the
time constant, expressed in the same units as the X-axis and is computed as the reciprocal
of K. Half-life is in the time units of the X-axis, computed as $\ln(2)/K$. Span is the
difference between Y_0 and Plateau, expressed in the same units as the Y-values. The linear
trapezoidal method was used for the AUC calculation. AUC is expressed as $U * h/L$ where
30 one unit is defined as the amount of enzyme required to hydrolyse 1 μ mol/h of 4-
methylumbelliferyl- β -D-glucopyranoside substrate at 37°C.

Example 2 – GBA constructs

In order to evaluate if a liver-directed gene therapy approach could be used to treat
5 Gaucher disease (GD), the human full-length GBA coding sequence (as found in GenBank
accession no. NM_000157.3; SEQ ID NO: 9) was cloned into a liver-specific promoter-
driven adeno-associated virus (AAV) vector. In FLF-PL01 AAV construct (Fig 1A) the
GBA wild type sequence (GBAwt, non-codon-optimized) is driven by a liver-specific
promoter referred to herein as ‘LSP-S’ (SEQ ID NO: 10). In order to determine a
10 sequence optimal for expression, sequences were designed using a number of different
codon optimisation strategies. In one example AAV construct (FLF-PL28) the GBA
codon sequence was optimized and is driven by the same liver specific promoter LSP-S
(Fig 1B). The FLF-PL64 construct contains the same GBA codon-optimized sequence as
FLF-PL28 but differs in containing a longer transcription regulatory element, referred to
15 here as ‘LSP-L’ (SEQ ID NO: 14) instead of LSP-S (Fig 1C).

Example 3 – Analysis of wild type GBA transgene expression

In order to evaluate if the (wild type) GBA construct FLF-PL01 could lead to liver
20 expression and subsequent secretion of β -glucocerebrosidase (GCCase) into the
bloodstream, FLF-PL01 was pseudotyped into AAV2/8. rAAV particles were produced
and titered as described above, and characterised by alkaline gel analysis, prior to be used
in mice. Eight-week-old wild type (C57BL/6) mice were treated with a single injection of
AAV2/8-FLF-PL01 at a dose ranging from 6×10^{11} to 6×10^{12} vg/kg. Control (naïve) mice
25 were left untreated. Serum samples were collected at four, eight, and 12 weeks post-AAV
injection and used to evaluate levels of circulating active GCCase. GCCase activity was
determined and immunohistochemistry staining was performed as described above.
Sections were counterstained with haematoxylin.

30 Injection of wild-type mice with AAV2/8-FLF-PL01 resulted in an increase in expression
of human GCCase in the liver of treated animals (Fig 2A). An increased level of GCCase

expression in liver could be observed with increased vector dose, with around 12-fold increase observed at the vector dose of 6×10^{11} vg/kg group, 43-fold at the dose of 2×10^{12} vg/kg, and 57-fold at the dose of 6×10^{12} vg/kg (Fig 2B). This data shows that AAV2/8-FLF-PL01 drove expression of GCCase to levels that result in significant release of GCCase to the bloodstream and possible access to macrophages in GD affected tissues.

Example 4 – Analysis of *in vitro* GCCase expression from codon-optimised constructs

Codon usage tables of various liver expressed sequences were used in order to generate GBA sequences codon-optimised throughout the stretch corresponding to the mature GCCase protein (but not the signal peptide-encoding region). With the exception of one such codon-optimised GBA sequence ('FLF-PL36') the resulting sequences were then further manually altered to remove CpGs, cryptic splice sites, premature stop codons and unwanted amino acid substitutions. Twenty-one codon-optimised GBA sequences were created and tested for GCCase expression levels upon transfection in the human liver cell line Huh-7. Huh-7 cells were plated onto a 12 well plate at the cell density of 3×10^5 per well and transfected as described above. Twenty microliters of medium was used to measure GCCase activity using 4MU-Glc as a substrate. Results from this analysis allowed the identification of GBA codon-optimizations (FLF-PL21, -PL28, -PL30, and -PL36) that demonstrated increased expression of GCCase (relative to wild type GBA sequence, FLF-PL01) when transfected in Huh-7 cells (Fig 3).

Example 5 – Analysis of *in vivo* GCCase activity from codon-optimised constructs

The four constructs (FLF-PL21, FLF-PL28, FLF-PL30 and FLF-PL36) identified in example 4 were pseudotyped as AAV2/8 and injection into wild-type mice at the dose of 2×10^{12} vg/kg. Also included in the experiment was the non-codon-optimised construct FLF-PL01, as well as a construct (FLF-PL37) containing the same wild type GBA sequence as FLF-PL01 driven by the strong synthetic promoter CAG. Control (naïve) mice were left untreated. At time points up to 36 weeks after injection, animals were sacrificed, and serum and tissues samples were collected.

Fig 4A shows the results at 8 weeks post-injection of GCCase activity found in mice injected either with the non-codon optimized GBA sequence driven by the LSP-S promoter (FLF-PL01), the codon-optimized GBA constructs (FLF-PL21, FLF-PL28, FLF-PL30 and FLF-PL36) also driven by the LSP-S promoter, and the GBA non-codon-optimized sequence driven by CAG promoter (FLF-PL37). All four GBA codon-optimized constructs showed increased levels of GCCase activity present in the bloodstream when injected in mice (Fig 4A), relative to FLF-PL01. The FLF-PL28 construct exhibited the greatest increase (about 6-fold) in GCCase release to the bloodstream compared to the non-codon-optimised construct driven by the same LSP-S promoter (FLF-PL01). The elevated level of GCCase driven by FLF-PL28 relative to FLF-PL01 was observed throughout the 36-week study period (Fig 4B).

Of particular note, the levels of GCCase observed in liver-specific promoter-containing FLF-PL28-injected mice were as high as the GCCase levels driven by the FLF-PL37 construct in which wild type GBA sequence is expressed from the ubiquitous and strong CAG promoter (Fig 4A).

At end-stage, spleen and bone marrow were collected and fixed in formalin, followed by paraffin embedding. GBA immunostaining analysis performed on paraffin sections shows that, in agreement with the circulating GCCase levels, tissue uptake of GCCase is increased in mice treated with the FLF-PL28 GBA codon-optimised construct compared to non-codon-optimised construct FLF-PL01 (Fig 5).

In order to evaluate levels of macrophage uptake in spleen upon liver-directed GBA expression by FLF-PL28, immunofluorescence analysis with the mouse pan-macrophage marker F4/80 and a GBA antibody was performed. The majority of F4/80 positive cells display expression of the human-specific GBA, suggesting that the majority of GCCase uptake in spleen occurs in macrophages (Fig 6).

30

Example 6 – Analysis of promoter effect on *in vivo* GCCase activity

To test if promoter engineering could further increase expression from a GBA codon-optimised sequence, the GBA construct from FLF-PL28 was placed under a liver-specific promoter (referred to herein as ‘LSP-L’; SEQ ID NO: 14) to generate construct FLF-PL64 (Example 2, Fig 1C).

AAV2/8 vectors were prepared with the new construct and injected into wild type mice at the dose of 2×10^{12} vg/kg. Control (naïve) mice were left untreated. After 5 weeks, animals were sacrificed, and serum and tissues were collected.

GCase activity analysis in serum shows that AAV2/8-FLF-PL64 results in an increased expression (about 2.5-fold, $P=0.0001$, one-way ANOVA) of GCase in the mouse bloodstream compared to mice treated with AAV2/8-FLF-PL28 (Fig 7).

Like construct FLF-PL28, FLF-PL64 allows robust uptake of GCase into GD target tissues such spleen, bone marrow and lung (Fig 8).

Example 7 – Liver expression selectivity from AAV vectors with GBA constructs

To analyse the selectivity of the LSP-L promoter for a hepatic cell line, eight human-derived cell lines from a variety of tissues were selected. Details of each cell line and its origin are summarized in the table below.

Table 1. Human-derived cell lines evaluated in this example

Cell line	Origin	Growth	Species of origin
HUH-7	Hepatocellular carcinoma (Liver)	Adherent	Human
HEK293T	Kidney	Adherent	Human
PANC-1	Pancreas (epithelioid carcinoma)	Adherent	Human
BxPC-3	Pancreas (adenocarcinoma)	Adherent	Human

MCF7	Breast (epithelial; adenocarcinoma)	Adherent	Human
1643	Neuroblastoma	Adherent	Human
MRC-9	Normal lung fibroblast (embryo)	Adherent	Human
697	B-cell leukaemia (early B-cell)	Suspension	Human

The eight human-derived cell lines as described above in Table 1 were grown in either DMEM, IMDM or RPMI media, supplemented with 10% FBS. For each cell line, 2×10^4 cells/well were transduced at a multiplicity of infection (MOI) of 1×10^5 vg/cell with AAV-FLF-PL64 (AAV with liver tropic capsid = SEQ ID NO: 20). All experiments were performed in duplicate. Cells in suspension were counted and transduced in serum-free media (300 μ l/well) into 48-well plates. For the adherent cell lines, media was aspirated, followed by washing with PBS (1X) and treatment with 5ml of TripLE for five minutes at 37°C, 5% CO₂, to dissociate the cells. The reaction was stopped by adding 5ml of complete media. Dissociated cells were counted using a Countess™ II Automated Cell Counter (ThermoFisher) and centrifuged (250 x g for five minutes), followed by resuspension in complete media at a density of 2×10^5 cells/ml. These cells were plated into 96-well plates (2×10^4 cells/well) to adhere for five hours prior to transduction. Transduction mix was prepared in X-VIVO media (50 μ l/well) and added to the cells. After three hours, 100 μ l/well of complete media was added. One day post-transduction, the media for each cell line was changed to complete media (+25mM HEPES for secretion analysis).

GCase activity was determined fluorometrically with 4-Methylumbelliferyl- β -D-glucopyranoside (4MU-Glc) as substrate.

GCase activity was measured from the culture supernatant for each cell line to determine the levels of GCase secreted following transduction with AAV-FLF-PL64 (Figure 10). When the LSP-L promoter drives the GBA transgene, GCase secretion was detected in the HUH-7 cell line alone. The level of active GCase observed in HUH-7 cells was

approximately 5.0 nmol/h/ml [5.1 ± 0.1 nmol/h/ml]. No detectable levels of active GCase were observed for any of the other cell lines analysed.

Example 8 – Comparison with ERT therapy

5

The goal of this example was to compare FLF-PL64 with VPRIV® (60 U/kg BW) when administered in mice as a single injection. VPRIV® contains the same amino acid sequence and a similar glycosylation pattern as the native enzyme, GCase (i.e. SEQ ID NO: 25), and therefore provides a suitable comparison. Patients undergoing enzyme replacement therapy (ERT) would be typically treated with an IV infusion of ERT (duration of infusion of 1–2 hours, clinical dose of VPRIV® is 60 U/kg) on alternate weeks.

VPRIV® powder (400 Units, Shire), for preparation of a solution for infusion, was obtained and maintained under refrigeration and protection from light until reconstitution. One vial (400U) was reconstituted with 4.3 ml of sterile water to achieve a solution at 100 U/ml, as recommended by the manufacturer. Following reconstitution, VPRIV solution was promptly snap frozen as single-use aliquots and stored at (-80 °C) for later use.

A single IV injection of either VPRIV® (60 U/kg BW) or FLF-PL64 (formulated as AAV2/8 particles, 2×10^{12} vg/kg), was administered to wild type mice. Levels of active GCase in serum and tissue were determined at various time points for up to one week and also at three weeks and five weeks post-injection. The levels of active GCase were determined fluorometrically with 4-Methylumbelliferyl- β -D-glucopyranoside (4MU-Glc).

25

As shown in Figure 11(A), VPRIV is rapidly cleared from murine blood. VPRIV reached a C_{max} of 12.7 μ mol/h/ml at two minutes post-injection; with an estimated half-life of approximately 5.6 minutes. At approximately 20 minutes post-injection, only residual levels of active GCase could be detected in serum. These levels remained close to untreated controls for the remainder of the study period. A comparison of VPRIV with FLF-PL64 was made by analysing mice with stable expression of GCase (Figure 11B).

30

Treatment with FLF-PL64 also led to increased levels of active GCCase in murine blood (C_{max} 9.4 µmol/h/ml) (Figure 11B). However, although levels of active GCCase were not as high as observed post-VPRIV® injection, these levels remained constant for the duration of the study. Table 2 below shows the predicted bioavailability during a 2-week interval in mice following injection of either ERT or FLF-PL64.

Table 2. Predicted bioavailability (AUC) during a 2-week interval in C57BL/6 mice upon single injection of ERT (60 U/kg BW) or AAV-FLF-PL64 (2x10¹² vg/kg).

	ERT (VPRIV®)	FLF-PL64
AUC _{2week} (min.U/ml)	18.6 ± 5.6	3,161.6 ± 348.2

Figure 12 shows GCCase immunostaining in murine liver, spleen and bone marrow following administration of VPRIV® or AAV2/8-FLF-PL64. A representative image for each animal group is shown. DAB (3,3'-Diaminobenzidine) was used to visualise GCCase and haematoxylin was used as counterstain. FLF-PL64 treated samples were obtained at five weeks post-injection, while VPRIV® treated samples were collected as labelled. A semi-quantitative analysis of the images are represented in Table 3 below:

Table 3: Relative levels of GCCase immunoreactivity observed in murine liver, spleen and bone marrow post-administration of either ERT (VPRIV®) or FLF-PL64. “-” refers to negative staining for GCCase; “+” represents positive staining for GCCase.

Group	Liver	Spleen	Bone Marrow
Naïve	-	-	-
ERT – 20 min	+	++	++
ERT – 60 min	+	+++	++
ERT – 240 min	+	-/+	-
ERT – 1440 min	-/+	-	-
FLF-PL64	+++	+++	++/+++

20

Example 9 – *in vivo* study of therapeutic potential

1. Methods

5 *Mouse methods*

9V/null mice carrying the *Gba1* mutation D409V/D409V (9V/9V) were used as the Gaucher disease model in this study. 9V/null mice have a nearly normal lifespan with visceral abnormalities (inflammation and storage cells) and substrate accumulation (Xu *et al.* Am J Pathol. 2003 Nov;163(5):2093-101; Xu *et al.* PLoS One. 2010 May
10 20;5(5):e10750). 9V/null mice were generated by crossing mice carrying *Gba1* mutation D409V/D409V (9V/9V) and *Gba1* null/WT. There are approximately two 9V/null produced in each litter. The strain background of 9V/null and WT mice are C57BL/6, 129SvEvBrd and FVB. 9V/null mice from multiple litters were randomly assigned into each treatment group on a rolling basis. Both male and female mice were enrolled in each
15 group with an attempt to balance gender in the groups. All mice were housed under pathogen-free conditions and were monitored daily and weighed weekly. All AAV treated mice showed normal growth and weight gain.

At the end of the study, mice were euthanized by pentobarbital (100 mg/kg). Mice were
20 transcardially perfused with saline. Liver, spleen and lung were then dissected.

AAV/VPRIV preparation and administration

Aliquots of AAV8-FLF-PL64 were stored at -80°C. Before injection, the aliquot was thawed on ice and diluted with X-VIVO 10 (Lonza, pH7.4, 4°C), and gently mixed by
25 vortexing briefly at low speed. The diluted AAV was kept on ice before injection and used within 2 hours.

VPRIV ® was resuspended and aliquoted (25, 50, 100 µl) and stored at -80°C. Before injection, the aliquot was thawed on ice and diluted with acidified X-VIVO 10 (Lonza,
30 pH5.5, 4°C) to indicated dose, and gently mixed by vortexing briefly at low speed. The diluted enzyme was kept on ice before injection and used within 2 hours.

AAV (2×10^{12} vg/kg) and vehicle (X-vivo) were given one time to 9V/null mice at 8 weeks of age with indicated doses at 5 μ L/g body weight (BW). WT mice were administrated with vehicle. AAV and vehicle administration were via tail vein to the mice
5 while briefly under isoflurane. VPRIV[®] was administered by tail vein bolus injection to 9V/null mice anesthetized with mixture of isoflurane and oxygen in bio-bubble room at 60U/kg and 2.5 μ L/g BW, starting at 8 weeks of age, biweekly, for 7 injections.

Tissue collection

10 Blood (~100 μ L) was collected from tail vein in a tube containing 0.5 M EDTA (5 μ L) at 12 weeks, 16 weeks and 20 weeks of age. Freshly collected blood samples were kept on ice and separated to plasma to assay for GCCase activity within 2 hours. Each plasma collection and activity assay from the VPRIV[®] treatment group was performed within 2 hours after the scheduled enzyme injection. A separate portion of blood (~400 μ L) was
15 processed to isolate white blood cells (WBC) for GCCase activity assay. Collected WBC was stored at -80°C.

Tissues (liver, lung, spleen, bone marrow) were collected at experimental endpoint (20 weeks of age). Tissue collection from the VPRIV[®] group was performed within 2 hours
20 after the final scheduled enzyme injection. Liver, lung and spleen samples were divided into 4 parts, with 3 parts frozen in individual tubes and stored at -80°C prior to GCCase activity assay, protein and substrate analysis. The remaining part was fixed in 10% Formalin for histology analysis. Bone marrow cells were collected from femurs and tibias of both legs of the mice and frozen in two tubes stored at -80°C freezer for GCCase activity
25 and substrate assays.

GCCase activity assay

Tissues were homogenized in 1% Na taurocholate and 1% Triton X-100 (Tc/Tx) using a Precellys Evolution tissue homogenizer for two cycles (20 seconds each, 30 seconds
30 interval) at 4°C. Cells (bone marrow (BM) and white blood cells (WBC)) were homogenized in 1% Tc/Tx with sonication at 4°C. Tissue and cell lysates (2 μ L) were

diluted (5 x) with reaction buffer in assay mixture (0.025 M Citrate-phosphate buffer, pH5.6). Diluted lysates (10 μ L) (in triplicate per sample) were loaded to reaction plate. GCase activity was determined fluorometrically with 4-methylumbelliferyl- β -D-glucopyranoside (4MU-Glucose, 4 mM) (Biosynth AG, Switzerland) in the presence and
5 absence of 2 mM Conduritol B epoxide (Millipore, CA) incubated for 1 hour at 37°C. Protein concentrations were determined using BCA Protein Assay Reagent (Pierce, Rockford, IL).

Plasma was diluted in 0.025 M Citrate-phosphate buffer, pH5.6. GCase activity was
10 determined fluorometrically with 4-methylumbelliferyl- β -D-glucopyranoside (4MU-Glucose, 4 mM) (Biosynth AG, Switzerland) as above.

Substrate analysis

Frozen tissues were weighed and homogenized in 3.6 mL of Methanol/Chloroform/H₂O
15 (2:1:0.6 v/v/v). Aliquots (500 μ L) of lysate were subjected to LC/MS analysis. The quantitated hexosylceramide and hexosylsphingosine were normalized by tissue weight.

Plasma was diluted in water (40 μ L plasma + 60 μ L water) and subjected to LC/MS
20 analysis. Substrate level was normalized by plasma volume.

Bone marrow cells were suspended in 200 μ L water and sonicated and vortexed to make cell lysate. 160 μ L lysate was subjected to LC/MS analysis. Remaining lysate was determined for protein concentration. Substrate level was normalized by mg protein.

25 LC/MS analysis was performed to analyse hexosylceramide and hexosylsphingosine concentrations. Since galatosylceramide and galatosylsphingosine levels are very low in this mouse model model, measured hexosylceramide and hexosylsphingosine concentrations represent levels of glucosylceramide and glucosylsphingosine, respectively.

30 *Histology analysis*

Liver, lung, spleen and bone marrow were dissected from saline perfused mice and fixed in Formalin (10%) and paraffin embedded. Fixed tissues were cut into 4 μm sections and mounted on slides.

5 *Storage cell count*

Tissue sections were stained with hematoxylin and eosin (H&E) by Autostainer (Leica Autostainer XL). The stained tissues were scanned with Aperio AT2 (Leica, 40X). The tissue images were processed with Aperio ImageScope (V12.4.0.0543). 10 photos of 20X magnitude (500 μm X 800 μm image) from liver and lung per mouse were chosen for
10 analysis. Storage cells were counted from each image. Average of cell counts from 10 images was calculated for data graph. Definition of “storage cells” is based on the size of cells (macrophage), e.g. size of storage cells in liver is > 10 μm , in lung is > 15 μm .

CD68 staining and quantification

15 Tissue sections were stained with rabbit anti-mouse CD68 antibody (1:25. Abcam Ab53444) in Discover Ultra automated IHC/ISH slide staining machine. The tissues were counter-stained with hematoxylin on cell nuclei. Stained tissues were scanned with Aperio AT2 (Leica, 40X) and the images were acquired by Aperio ImageScope (V12.4.0.0543). The images of liver and lung at 20X magnitude (500 μm X 800 μm) were used for
20 quantitative analysis. IHC signals from 5 images of liver or lung per mouse were analysed using Image J (Fiji, v5.1). Average CD68 signals per mouse was calculated for data graph.

Statistical analyses

The data was analysed by Student’s t-test or OneWay ANOVA. Figure graphs and
25 statistical analysis were generated by PRISM 8 software (PRISM version 8.0.1).

2. Results

GCase activity

30 AAV-FLF-PL64 treatment to restore active GCase levels in 9V/null mice was studied by measuring GCase activity in cells and tissues. White blood cells (WBC), bone marrow and

tissue samples were collected at the experimental end point as above (i.e. 12 weeks post AAV-FLF-PL64 injection or on the final VPRIV ® administration), when the mice are at 20 weeks of age.

- 5 VPRIV ® was shown to increase the activity across all cells and tissues tested (Figure 13). As stated above, tissues of the VPRIV ® treated group were collected within 2 hours post last injection, and this is in line with previous data showing that this is within the period where VPRIV ® is at its C-max in the tissues.
- 10 AAV-FLF-PL64 was shown to also significantly increase GCase activity in all tissues following only a single administration (Figure 13). Compared to Vehicle-9V/null, liver GCase activity increased by 4.7-fold, and spleen GCase activity increased by 2.5-fold. In white blood cells GCase activity was seen to significantly increase in the AAV-FLF-PL64 treated groups by 7-9 fold. In particular, the GCase activity level in white blood cells
15 reached to about 82% of WT activity levels.

Tissue Histology

Visceral pathology in 9V/null mice was determined by counting foamy macrophages as storage cells and quantitating CD68 staining signals on activated macrophages. The storage
20 cells were counted in H&E stained liver sections. CD68 signal (brown colour) intensity was quantified on anti-CD68 antibody stained liver and lung sections.

Storage cells at size $\geq 10 \mu\text{m}$ in liver were counted from 10 images per tissues of each mouse. In liver, the number of storage cells was undetectable in the AAV-FLF-PL64
25 treated groups, as well as in the VPRIV ® group. (Figure 14)

CD68 signals in liver were also significantly decreased in the AAV-FLF-PL64 treated groups. AAV-FLF-PL64 treatment reduced CD68 signals to about 25% of Vehicle-9V/null level. In comparison, CD68 signals in VPRIV group was about 37% of Vehicle-9V/null
30 level. (Figure 14)

Substrate accumulation

9V/null mice are known to develop glycolipid substrates accumulation in liver, lung and spleen (Xu et al. PLoS One. 2010 May 20;5(5):e10750). For example, the study showed that hexosylceramide in the control Vehicle-9V/null group is above WT level by 7.97-fold
5 in liver and 3.57-fold in spleen (data not shown).

AAV-FLF-PL64 treated groups showed significant reduction of hexosylceramide and hexosylsphingosine in the liver and spleen compared to Vehicle-9V/null (Figure 15). In particular, AAV-FLF-PL64 treated groups had hexosylceramide levels reduced to 1.20-
10 fold times the wild-type level in liver and 1.03-fold times the wild-type level in spleen (data not shown). Similar reduction to close to the WT level was seen upon analysis of bone marrow (data not shown).

On the other hand, VPRIV[®] treatment only showed a significant reduction of
15 hexosylceramide in liver, with the other tested tissues showing no significant changes in the hexosylceramide levels. VPRIV[®] did not appear to have any significant effect on hexosylsphingosine levels in any tested tissue.

20 It will of course be understood that, although the present invention has been described by way of example, the examples are in no way meant to be limiting, and modifications can be made within the scope of the claims hereinafter. Preferred features of each embodiment of the invention are as for each of the other embodiments *mutatis mutandis*. All
publications, including but not limited to patents and patent applications, cited in this
25 specification are herein incorporated by reference as if each individual publication was specifically and individually indicated to be incorporated by reference herein.

Claims

1. A polynucleotide comprising a GBA nucleotide sequence, wherein the GBA nucleotide sequence encodes a β -Glucocerebrosidase (GCCase) protein or fragment thereof and wherein at least a portion of the GBA nucleotide sequence is not wild type, optionally wherein the portion of the GBA nucleotide sequence that is not wild type is codon-optimised, more optionally wherein the GBA nucleotide sequence encodes a GCCase protein or a fragment thereof and comprises a sequence that is:
- 5
- (i) 100% identical to a nucleotide sequence of any one of SEQ ID NO: 1-8;
- 10 (ii) at least 95%, at least 96%, at least 97%, at least 98%, at least 99%, at least 99.5%, at least 99.8%, or at least 100% identical to a nucleotide sequence of any one of SEQ ID NO: 1-8; and/or
- (iii) a variant of any one of SEQ ID NO: 1-8 encoding a GCCase protein having GCCase activity, wherein the variant is identical to SEQ ID NO: 1-8 respectively
- 15 except that it comprises nucleotide substitutions such that the GCCase protein has 1, up to 2, up to 3, up to 4, up to 5, up to 6, up to 7, up to 8, up to 9, or up to 10 amino acid substitutions relative to the wild type GCCase amino acid sequence of SEQ ID NO: 25.
- 20 2. The polynucleotide of claim 1, wherein the GBA nucleotide sequence comprises a sequence that is:
- (i) 100% identical to a nucleotide sequence of SEQ ID NO: 1 or SEQ ID NO: 5;
- (ii) at least 95%, at least 96%, at least 97%, at least 98%, at least 99%, at least 99.5%, or at least 99.8% identical to a nucleotide sequence of SEQ ID NO: 1 or SEQ
- 25 ID NO: 5; and/or
- (iii) a variant of SEQ ID NO: 1 or SEQ ID NO: 5 encoding a GCCase protein having GCCase activity, wherein the variant is identical to SEQ ID NO: 1 or SEQ ID NO: 5 respectively except that it comprises nucleotide substitutions such that the GCCase protein has 1, up to 2, up to 3, up to 4, up to 5, up to 6, up to 7, up to 8, up to 9, or up to
- 30 to 10 amino acid substitutions relative to the wild type GCCase amino acid sequence of SEQ ID NO: 25.

3. The polynucleotide of claim 1 or 2, wherein the variant is a variant of SEQ ID NO: 1 and the variant of SEQ ID NO: 1:

5 (i) is identical to SEQ ID NO: 1 except that it comprises nucleotide substitutions such that the GCCase protein has 1, up to 2, up to 3, up to 4, up to 5, up to 6, up to 7, up to 8, up to 9, or up to 10 amino acid substitutions relative to the wild type GCCase amino acid sequence of SEQ ID NO: 25;

10 (ii) has 1, up to 2, up to 3, up to 4, up to 5, up to 6, up to 7, up to 8, up to 9, up to 10, up to 20, or up to 30 nucleotide substitutions relative to the sequence of SEQ ID NO: 1;

(iii) has 1, up to 2, up to 3, up to 4, up to 5, or up to 6 nucleotide substitutions relative to the sequence of SEQ ID NO: 1;

15 (iv) has up to 4 nucleotide substitutions relative to the sequence of SEQ ID NO: 1 and/or encodes a GCCase protein having up to 3 amino acid substitutions relative to the wild type amino acid GCCase sequence of SEQ ID NO: 25;

(v) has up to 3 nucleotide substitutions relative to the sequence of SEQ ID NO: 1 and/or encodes a GCCase protein having up to 2 amino acid substitutions relative to the wild type GCCase amino acid sequence of SEQ ID NO: 25; and/or

20 (vi) has 1 nucleotide substitution relative to the sequence of SEQ ID NO: 1 and/or encodes a GCCase protein having up to 1 amino acid substitution relative to the wild type GCCase amino acid sequence of SEQ ID NO: 25.

4. The polynucleotide of claim 1 or 2, wherein the variant is a variant of SEQ ID NO: 5 and the variant of SEQ ID NO: 5:

25 (i) is identical to SEQ ID NO: 5 except that it comprises nucleotide substitutions such that the GCCase protein has 1, up to 2, up to 3, up to 4, up to 5, up to 6, up to 7, up to 8, up to 9, or up to 10 amino acid substitutions relative to the wild type GCCase amino acid sequence of SEQ ID NO: 25;

30 (ii) has 1, up to 2, up to 3, up to 4, up to 5, up to 6, up to 7, up to 8, up to 9, up to 10, up to 20, or up to 30 nucleotide substitutions relative to the sequence of SEQ ID NO: 5;

- (iii) has 1, up to 2, up to 3, up to 4, up to 5, or up to 6 nucleotide substitutions relative to the sequence of SEQ ID NO: 5;
- (iv) has up to 4 nucleotide substitutions relative to the sequence of SEQ ID NO: 5 and/or encodes a GCCase protein having up to 3 amino acid substitutions relative to the wild type amino acid GCCase sequence of SEQ ID NO: 25;
- (v) has up to 3 nucleotide substitutions relative to the sequence of SEQ ID NO: 5 and/or encodes a GCCase protein having up to 2 amino acid substitutions relative to the wild type GCCase amino acid sequence of SEQ ID NO: 25; and/or
- (vi) has 1 nucleotide substitution relative to the sequence of SEQ ID NO: 5 and/or encodes a GCCase protein having up to 1 amino acid substitution relative to the wild type GCCase amino acid sequence of SEQ ID NO: 25.
- 5
- 10
5. The polynucleotide of any one of the preceding claims, wherein the GBA nucleotide sequence encodes a GCCase protein having:
- 15 (i) up to 3 amino acid substitutions relative to the wild type GCCase amino acid sequence of SEQ ID NO: 25;
- (ii) up to 2 amino acid substitutions relative to the wild type GCCase amino acid sequence of SEQ ID NO: 25; and/or
- (iii) up to 1 amino acid substitution relative to the wild type GCCase amino acid sequence of SEQ ID NO: 25.
- 20
6. A polynucleotide comprising a GBA nucleotide sequence, wherein the GBA nucleotide sequence encodes a GCCase protein or a fragment thereof and comprises a sequence that is at least 95%, at least 96%, at least 97%, at least 98%, at least 99%, at least 99.5%, at least 99.8%, or 100% identical to a fragment of at least 1000, at least 1200, at least 1300, less than 1494, less than 1611, between 1000 and 1494, between 1000 and 1611, between 1300 and 1494, between 1300 and 1611, around 1494, or around 1611 nucleotides of any one of SEQ ID NO: 1-8.
- 25
- 30 7. The polynucleotide of any one of the preceding claims, wherein at least a portion of the GBA nucleotide sequence is codon-optimised.

8. The polynucleotide of claim 7, wherein:
- (a) the at least a portion of the GBA nucleotide sequence that is codon-optimised is codon-optimised for expression in human liver cells;
 - 5 (b) the portion of the GBA nucleotide sequence that is codon-optimised is a contiguous portion;
 - (c) the GBA nucleotide sequence is codon-optimised for expression in human liver cells;
 - (d) the portion of the GBA nucleotide sequence that is codon-optimised is at
10 least 1000, at least 1200, at least 1300, less than 1494, between 1000 and 1494, between 1300 and 1494, or around 1494 nucleotides in length;
 - (e) the portion of the GBA nucleotide sequence that is codon-optimised corresponds to a mature GCCase protein;
 - (f) the portion of the GBA nucleotide sequence that is codon-optimised does
15 not encode all or a portion of a signal peptide;
 - (g) the GBA nucleotide sequence or the portion of the GBA nucleotide sequence that is codon-optimised comprises a reduced number of CpGs compared to a corresponding portion of a wild type GBA nucleotide sequence; optionally wherein the GBA nucleotide sequence or the portion of the GBA nucleotide sequence that is
20 codon-optimised comprises less than 40, less than 20, less than 18, less than 10, or less than 5 CpGs, more optionally wherein the GBA nucleotide sequence or the portion of the GBA nucleotide sequence that is codon-optimised comprises less than 5, less than 4, less than 3, or less than 2 CpGs per 100 nucleotides, more optionally wherein the GBA nucleotide sequence or the portion of the GBA nucleotide
25 sequence that is codon-optimised is CpG-free, preferably wherein the wild type GBA nucleotide sequence is SEQ ID NO: 9;
 - (h) the portion of the GBA nucleotide sequence that is codon-optimised is at least 80%, at least 85%, at least 90%, at least 95%, at least 98%, at least 99%, at least 99.5%, at least 99.8%, or 100% identical to a fragment of at least 1000, at least 1200,
30 at least 1300, less than 1494, between 1000 and 1494, between 1300 and 1494, or around 1494 nucleotides of any one of SEQ ID NO: 1-4; and/or

- (i) the portion of the GBA nucleotide sequence that is codon-optimised is at least 99%, at least 99.5%, at least 99.8%, or 100% identical to SEQ ID NO: 1.
9. The polynucleotide of any one of the preceding claims, wherein the GBA nucleotide
5 sequence comprises a portion that is not codon-optimised, optionally wherein:
- (a) the portion that is not codon-optimised encodes all or a portion of a GCase signal peptide;
- (b) the portion that is not codon-optimised is at least 80, at least 90, at least 100,
at least 110, less than 200, less than 170, less than 140, or around 117 nucleotides;
10 and/or
- (c) the portion that is not codon-optimised comprises 1 or more CpGs.
10. The polynucleotide of any one of the preceding claims, wherein the polynucleotide
further comprises a transcription regulatory element, optionally wherein the
15 transcription regulatory element comprises a liver-specific promoter and/or an enhancer.
11. The polynucleotide of claim 10, wherein the transcription regulatory element
comprises an A1AT promoter or a fragment of an A1AT promoter, optionally
20 wherein:
- (a) the A1AT promoter or the fragment of an A1AT promoter is at least 100, at
least 120, at least 150, at least 180, less than 255, between 100 and 255, between 150
and 225, between 150 and 300, or between 180 and 255 nucleotides in length, more
optionally wherein the fragment of an A1AT promoter is between 180 and 255
25 nucleotides in length;
- (b) the A1AT promoter or the fragment of an A1AT promoter is at least 200, at
least 250, at least 300, less than 500, between 200 and 500, between 250 and 500,
between 350 and 450, or around 418 nucleotides in length, more optionally wherein
the fragment of an A1AT promoter is between 350 and 450 nucleotides in length;
30 and/or

- (c) the polynucleotide comprises a promoter that is at least 80%, at least 85%, at least 90%, at least 95%, at least 98%, at least 99%, at least 99.5%, at least 99.8%, or 100% identical to SEQ ID NO: 15 or SEQ ID NO: 12.
- 5 12. The polynucleotide of claims 10 or 11, wherein the enhancer is an HCR enhancer or a fragment of an HCR enhancer, optionally wherein:
- (a) the HCR enhancer or the fragment of an HCR enhancer is a fragment of at least 80, at least 90, at least 100, less than 192, between 80 and 192, between 90 and 192, between 100 and 250, or between 117 and 192 nucleotides in length, more
10 optionally wherein the fragment of an HCR enhancer is between 117 and 192 nucleotides in length;
- (b) the HCR enhancer or the fragment of an HCR enhancer is a fragment of at least 150, at least 190, at least 230, less than 400, between 150 and 400, between 190 and 370, between 230 and 340, between 250 and 340, or around 321 nucleotides in
15 length, more optionally wherein the fragment of an HCR enhancer is between 250 and 340 nucleotides in length;
- (c) the polynucleotide comprises an enhancer that is at least 80%, at least 85%, at least 90%, at least 95% at least 98%, at least 99%, at least 99.5%, at least 99.8%, or 100% identical to SEQ ID NO: 16 or SEQ ID NO: 11.
20
13. The polynucleotide of claim 10, wherein the transcription regulatory element is at least 80%, at least 85%, at least 90%, at least 95%, at least 98%, at least 99%, at least 99.5%, at least 99.8%, or 100% identical to SEQ ID NO: 14 or 10.
- 25 14. The polynucleotide of any one of the preceding claims, wherein the GCase encoded by the GBA nucleotide sequence is expressed in human liver cells at higher levels compared to a GCase encoded by a wild type GBA nucleotide sequence in an otherwise identical reference polynucleotide, optionally wherein the GCase encoded by the GBA nucleotide sequence is expressed in human liver cells at least 1.1x, at
30 least 1.2x, at least 1.3x, at least 1.4x, or at least 1.5x higher compared to a GCase encoded by a wild type GBA nucleotide sequence in an otherwise identical reference

polynucleotide, more optionally wherein the reference polynucleotide comprises a wild type GBA nucleotide sequence of SEQ ID NO: 9, optionally wherein the reference polynucleotide comprises a promoter of SEQ ID NO: 13.

- 5 15. A viral particle comprising a recombinant genome comprising the polynucleotide of any one of the preceding claims.
16. The viral particle of claim 15, which is an AAV, adenoviral, or lentiviral viral particle, optionally which is an AAV viral particle.
- 10 17. The viral particle of claim 15 or 16, wherein the viral particle comprises a liver-tropic or CNS-tropic capsid.
18. The viral particle of claim 17, wherein the liver-tropic capsid comprises a sequence
15 at least 98%, at least 99%, at least 99.5% to a fragment of at least 600, at least 650, at least 700, between 600 and 736, between 650 and 736 or between 700 and 736 amino acids of SEQ ID NO: 19, 20 or 24, optionally wherein the liver-tropic capsid comprises a sequence at least 99% identical to SEQ ID NO: 19 or 20.
- 20 19. The viral particle of claim 17, wherein the CNS-tropic capsid comprises a sequence at least 98%, at least 99%, at least 99.5% to a fragment of at least 600, at least 650, at least 700, between 600 and 736, between 650 and 736 or between 700 and 736 amino acids of SEQ ID NO: 21, optionally wherein the CNS-tropic capsid comprises a sequence at least 99% identical to SEQ ID NO: 21.
- 25 20. The viral particle of any one of claims 15 to 19, wherein the recombinant genome further comprises:
- a) AAV2 ITRs;
 - b) a poly A sequence; and/or
 - 30 c) an intron;
- optionally wherein the recombinant genome is single-stranded.

21. The viral particle of any one of claims 15 to 20, wherein on transduction into Huh-7 cells, the viral particle expresses GCase or a fragment thereof such that the GCase activity in the transduced cell is greater than the activity of GCase or a fragment thereof in a cell transduced with an otherwise identical viral particle comprising a
5 GBA nucleotide sequence of SEQ ID NO: 9, optionally wherein on transduction into Huh-7 cells, the viral particle expresses GCase or a fragment thereof such that the GCase activity in the transduced cell is at least 2x, at least 3x, at least 4x, at least 5x, at least 10x, or at least 20x greater than the activity of GCase or a fragment thereof in
10 a cell transduced with an otherwise identical viral particle comprising a GBA nucleotide sequence of SEQ ID NO: 9, more optionally wherein the activity is measured using a fluorometric substrate which is specific for GCase.
22. A composition comprising the polynucleotide or viral particle of any one of the preceding claims and a pharmaceutically acceptable excipient.
15
23. The polynucleotide, viral particle or composition of any one of the preceding claims for use in a method of treatment.
24. The polynucleotide, viral particle or composition for use of claim 23, wherein the
20 method of treatment comprises administering an effective amount of the polynucleotide, composition or viral particle of any one of claims 1 to 22 to a patient.
25. The polynucleotide, viral particle, or composition for use of any one of claims 23 to
25 24, wherein the method of treatment is a method of treating a disease associated with GCase deficiency.
26. The polynucleotide, viral particle, or composition for use of any one of claims 23 to
30 24, wherein the method of treatment is a method of treating Parkinson's disease.

27. The polynucleotide, viral particle, or composition for use of any one of claims 23 to 24, wherein the method of treatment is a method of treating Gaucher disease, optionally wherein:
- (i) the Gaucher disease is Gaucher disease type I, II or III; and/or
 - 5 (ii) the patient has antibodies or inhibitors to a recombinant GCCase with which the patient has previously been treated as part of an enzyme replacement therapy.
28. The polynucleotide, viral particle or composition of any one of claims 1 to 22, for use in a method of expressing the GBA nucleotide sequence and achieving a stable
- 10 GCCase activity in a subject.
29. The polynucleotide, viral particle or composition of any one of claims 1 to 22, for use in a method of expressing the GBA nucleotide sequence and providing greater GCCase bioavailability in a subject compared to the bioavailability from GCCase
- 15 enzyme replacement therapy, wherein the bioavailability is measured over a period of 2 weeks from administration.
30. The polynucleotide, viral particle or composition for use of claim 28 or 29, wherein achieving a stable GCCase activity and/or providing greater GCCase bioavailability
- 20 leads to the treatment of a disease in the subject.
31. The polynucleotide, viral particle or composition for use of any of claims 28 to 30, wherein:
- (i) the GCCase activity and/or bioavailability is measured using a fluorometric
 - 25 substrate which is specific for GCCase;
 - (ii) the GCCase activity is measured in the serum or plasma of the subject;
 - (iii) the GCCase activity is measured in the macrophages of the subject;
 - (iv) the GCCase activity is stable at a level of at least 1, at least 2, at least 3, at least 4, at least 5, at least 6, at least 7, at least 8, or at least 9 $\mu\text{mol/h/ml}$ in the subject;
 - 30 (v) the GCCase activity is stable at a level of at least 3 $\mu\text{mol/h/ml}$ in the subject;
 - (vii) the GCCase activity is stable at a level of at least 5 $\mu\text{mol/h/ml}$ in the subject;

- (vii) the GCCase activity is stable at a level of at least 9 $\mu\text{mol/h/ml}$ in the subject;
- (viii) the method comprises administering an effective dose of the polynucleotide, viral particle or composition to the subject;
- (ix) the stable GCCase activity is a GCCase activity of at least 10%, at least 20%, at least 30%, at least 40%, or at least 50% relative to the GCCase activity of a healthy subject;
- (x) the stable GCCase activity is a GCCase activity of between 10% and 100%, between 20% and 90%, between 30% and 70%, between 40% and 70%, or between 50% and 70% relative to the GCCase activity of a healthy subject;
- (xi) the stable GCCase activity is stable for at least 5 weeks from administration;
- (xii) the stable GCCase activity is stable for at least 10 weeks from administration;
- (xiii) the stable GCCase activity is stable for at least 15 weeks from administration;
- (xiv) the stable GCCase activity is stable for at least 20 weeks from administration;
- (xv) the stable GCCase activity is stable for at least 25 weeks from administration;
- (xvi) the stable GCCase activity is stable for at least 30 weeks from administration;
- (xvii) the stable GCCase activity is stable for at least 35 weeks from administration;
- (xviii) the stable GCCase activity is stable for at least 40 weeks after administration;
- (xix) the method achieves a greater GCCase activity in the liver, spleen, and/or bone marrow of the subject at least 5, at least 10, at least 15, at least 20, at least 25, at least 30, or at least 35 weeks after administration when compared to the activity measured in a subject administered an effective dose of a GCCase enzyme replacement therapy, when measured in the same assay at the same time point after administration; and/or
- (xx) the method achieves a greater GCCase bioavailability in the liver spleen and/or bone marrow subject over a period of at least 5, at least 10, at least 15, at least 20, at least 25, at least 30, or at least 35 weeks after administration when compared to the bioavailability measured in a subject administered an effective dose of a GCCase enzyme replacement therapy, when measured in the same assay at the same time point after administration.

32. The polynucleotide, viral particle or composition for use of any of claims 30 to 31, wherein the disease is Gaucher disease, optionally wherein the Gaucher disease is Gaucher disease type I, II or III.
- 5 33. The polynucleotide, viral particle or composition of any one of claims 1 to 22, for use in a method of reducing hexosylceramide and/or hexosylsphingosine levels in a subject suffering from a disease or condition associated with GCCase deficiency, optionally wherein reducing hexosylceramide and/or hexosylsphingosine levels leads to the treatment of the disease or condition associated with GCCase deficiency.
- 10
34. The polynucleotide, viral particle or composition for use of claim 33, wherein:
- (i) the hexosylceramide and/or hexosylsphingosine levels are reduced by 2 times or more, 3 times or more, 4 times or more, 5 times or more, 6 times or more, 2 to 3 times, 2 to 4 times, 2 to 5 times, 2 to 6 times, or 3 to 5 times when compared to the
- 15 hexosylceramide and/or hexosylsphingosine levels at the time of administration of the polynucleotide, viral particle or composition of any one of claims 1 to 22;
- (ii) the reduction in hexosylceramide and/or hexosylsphingosine levels is greater than the reduction achieved in a subject administered an effective dose of a GCCase enzyme replacement therapy, optionally when the hexosylceramide and/or
- 20 hexosylsphingosine levels are measured at least 6 weeks, at least 8 weeks, at least 10 weeks or at least 12 weeks after administration;
- (iii) the hexosylceramide and/or hexosylsphingosine levels are measured in the macrophages of the subject;
- (iv) the hexosylceramide and/or hexosylsphingosine levels are measured in the
- 25 spleen of the subject;
- (v) the hexosylceramide and/or hexosylsphingosine levels are measured in the liver of the subject;
- (vi) the hexosylceramide and/or hexosylsphingosine levels are measured in the serum of the subject;
- 30 (vii) the hexosylceramide and/or hexosylsphingosine levels are measured by mass spectrometry; and/or

(viii) the disease is Gaucher disease, optionally wherein the Gaucher disease is Gaucher disease type I, II or III.

35. The polynucleotide, viral particle, or composition for use, or method of any one of
5 claims 23 to 34, wherein the patient has antibodies or inhibitors to a recombinant
GCase with which the patient has previously been treated as part of an enzyme
replacement therapy.

10

FIGURE 1

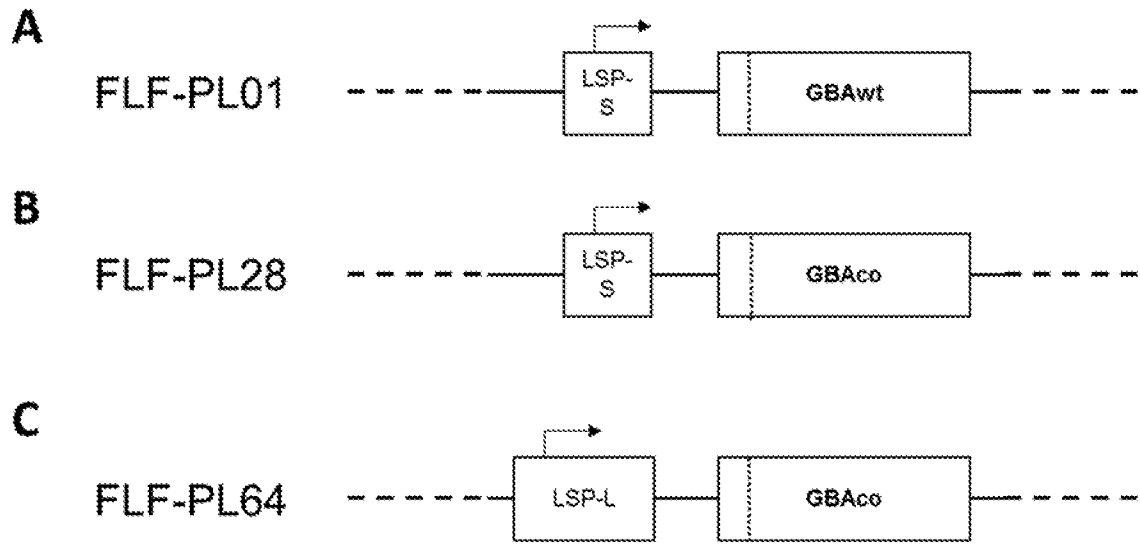

FIGURE 2

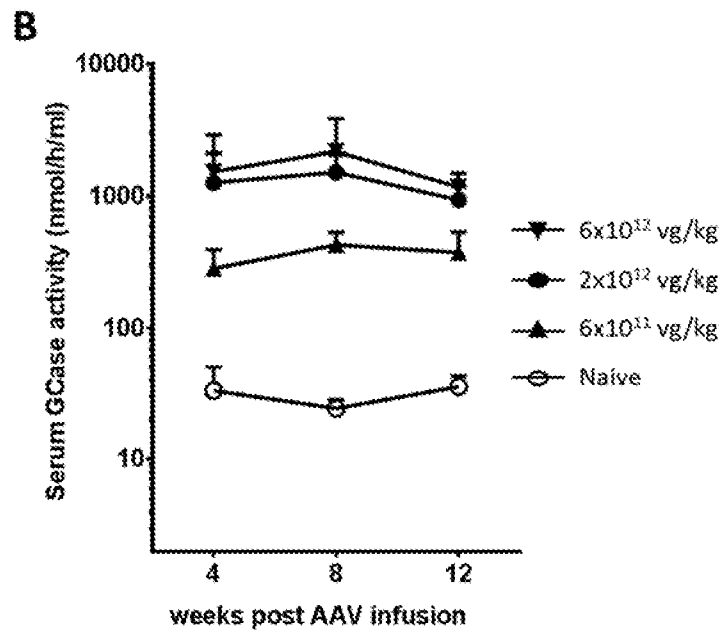
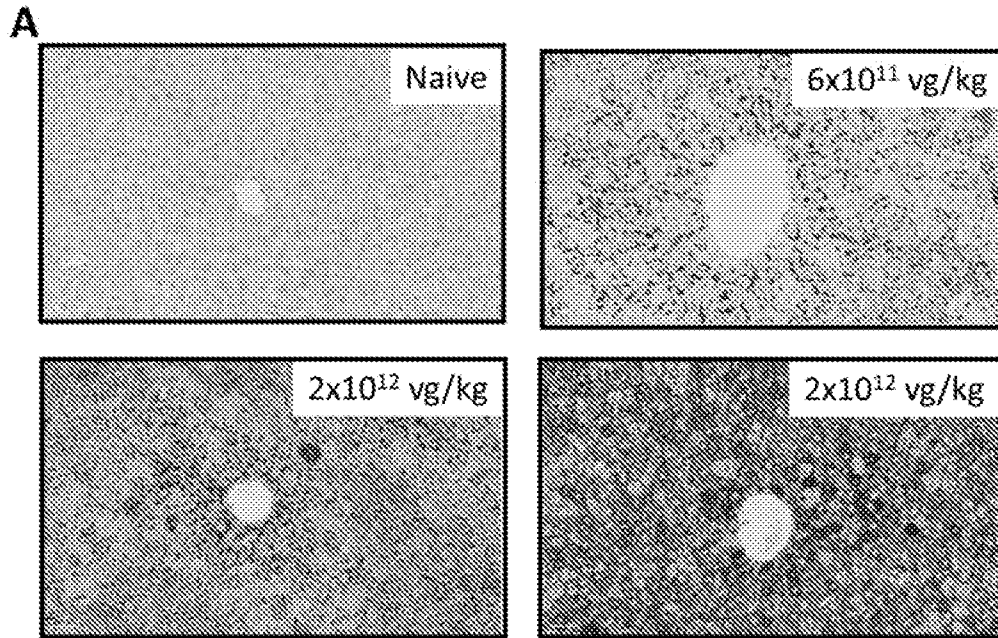

FIGURE 3

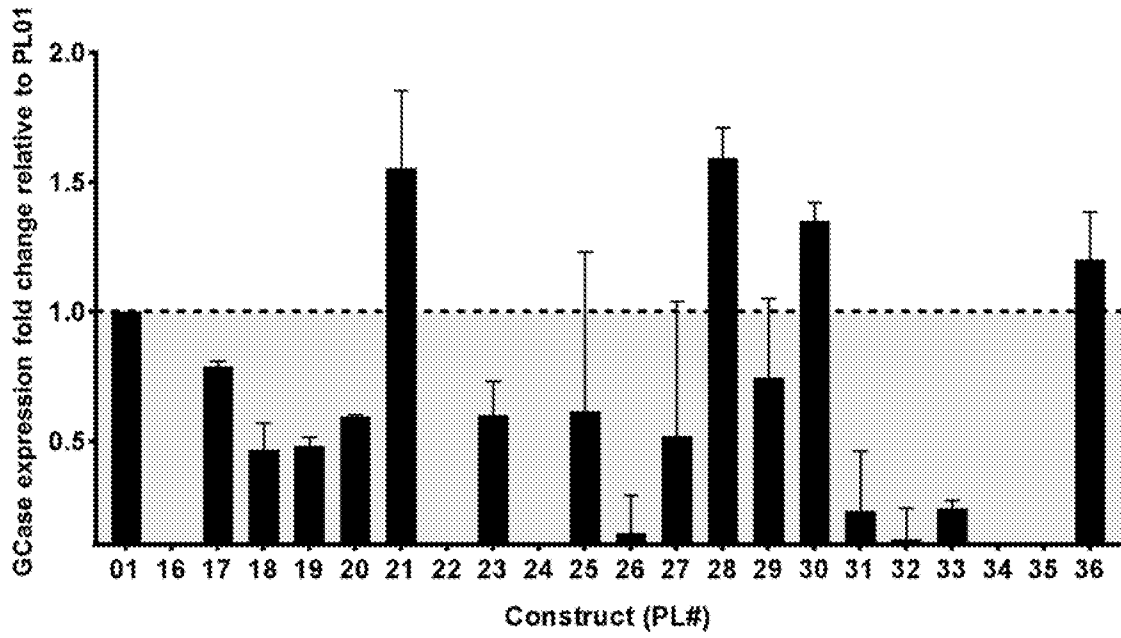
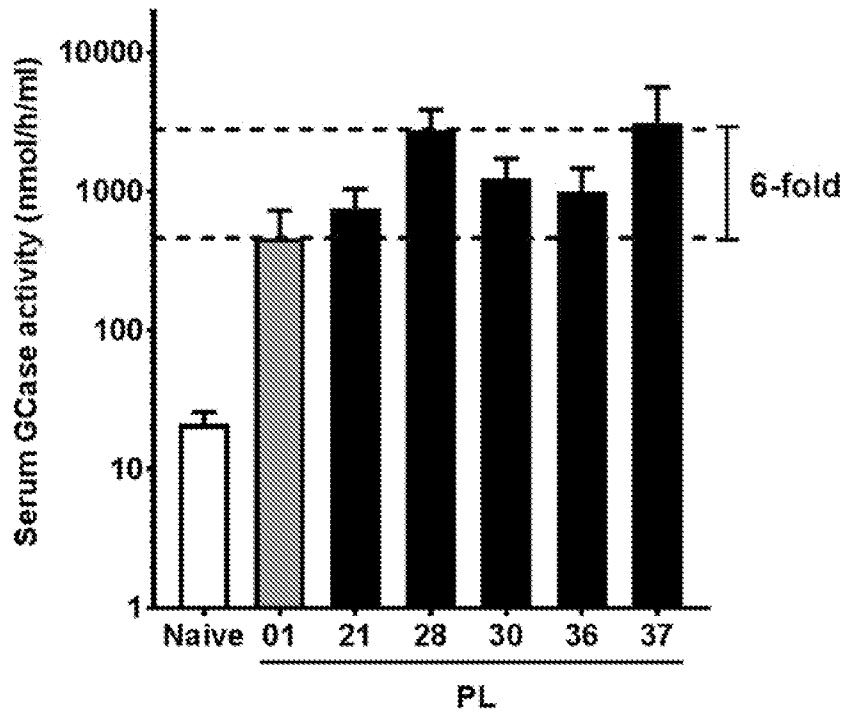

FIGURE 4

A



B

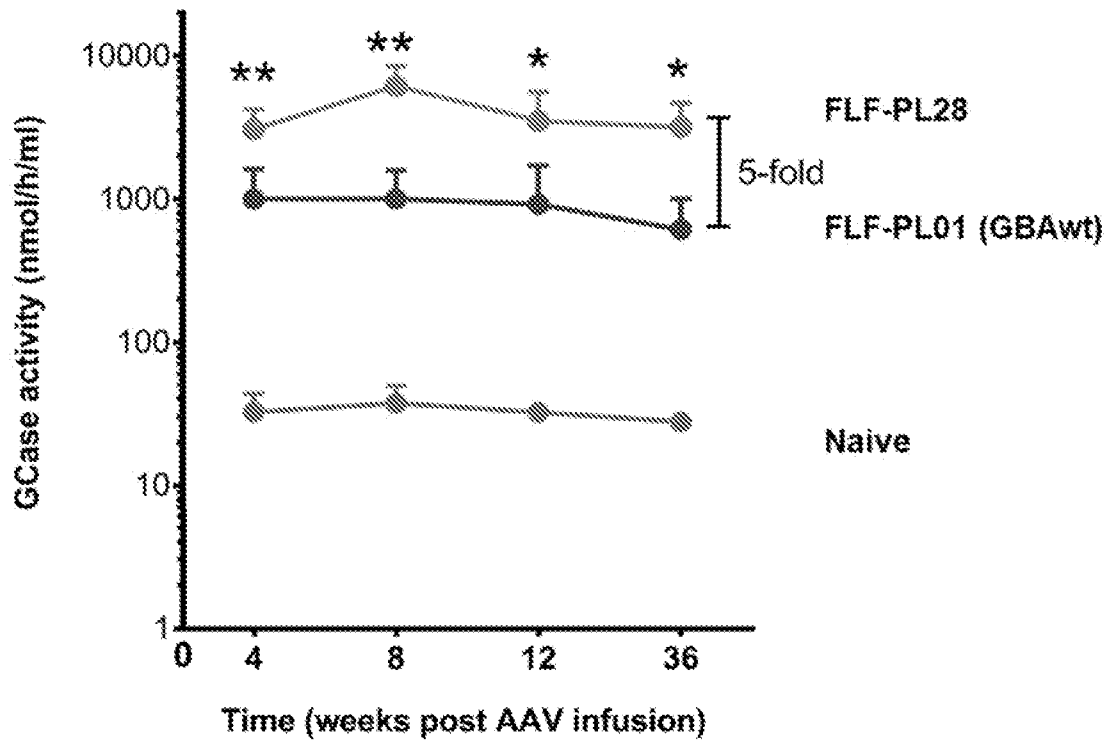

FIGURE 5

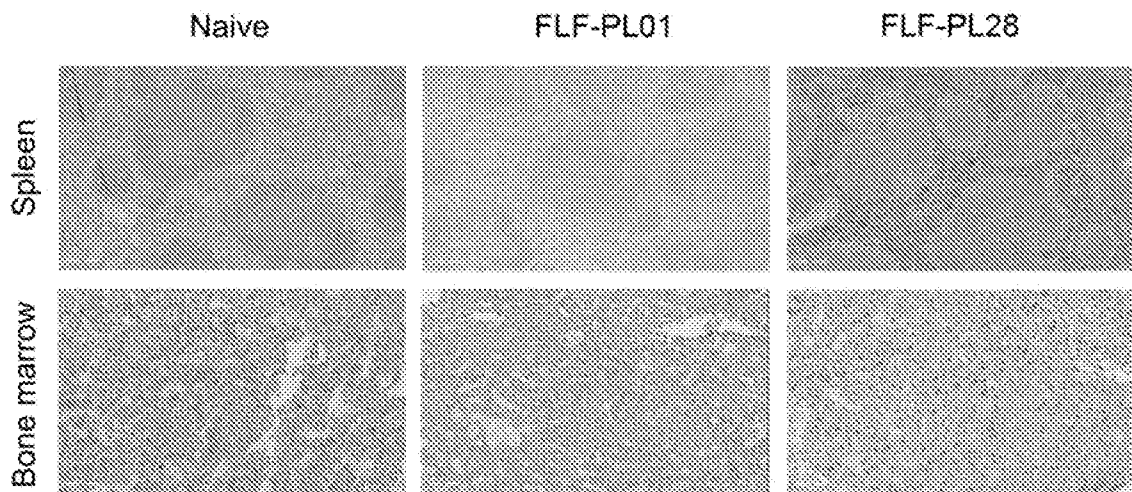

FIGURE 6

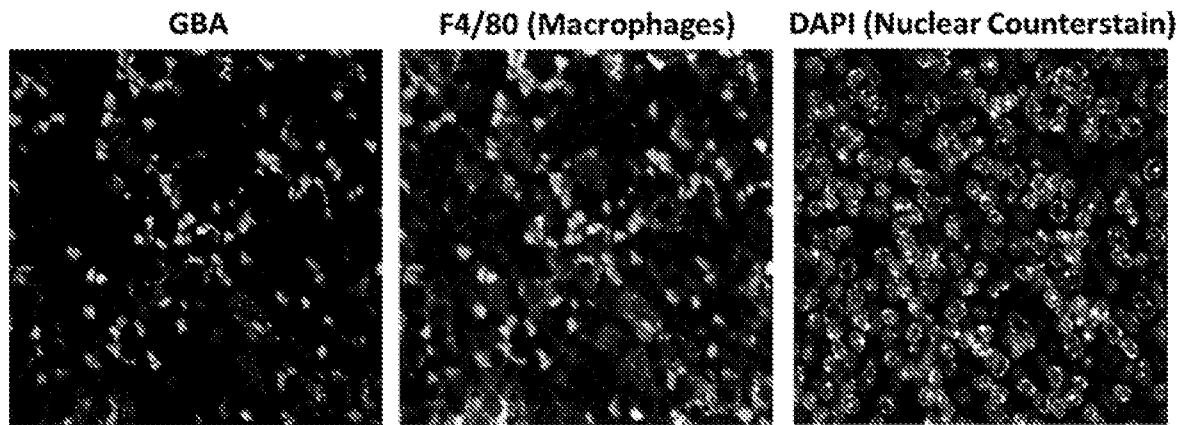

FIGURE 7

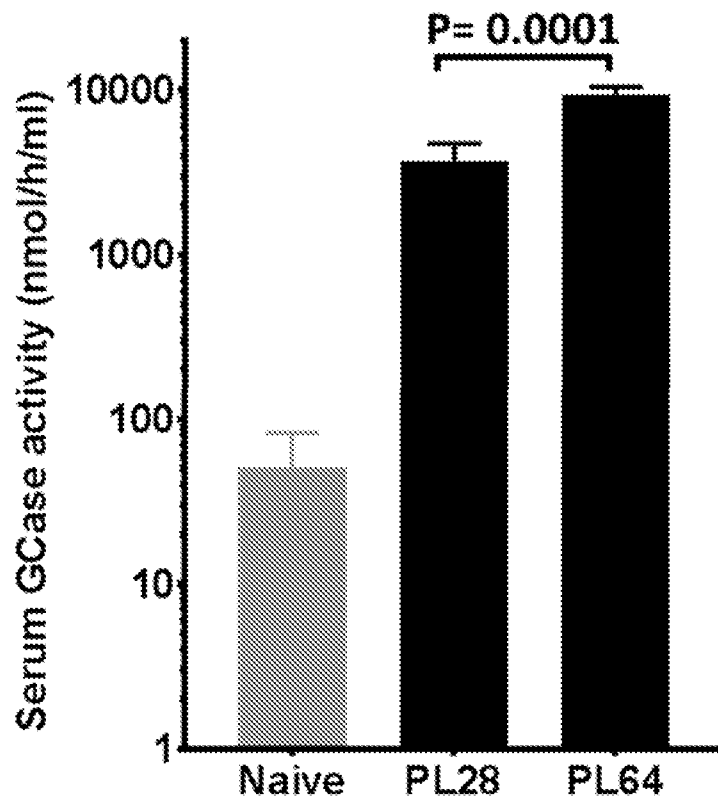

FIGURE 8

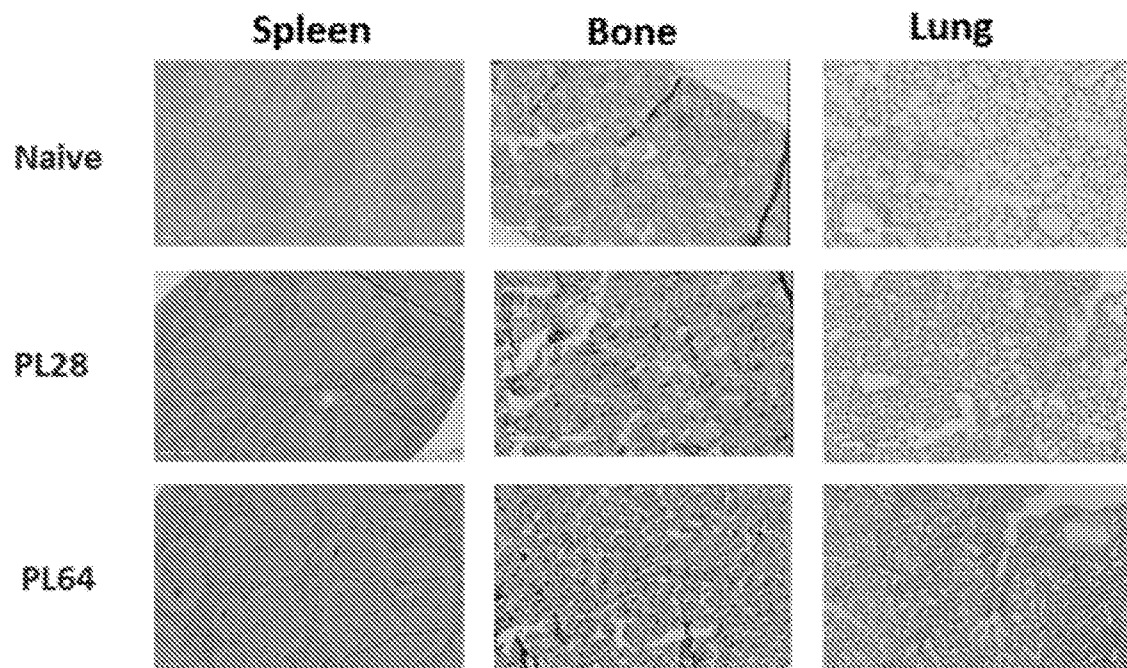

FIGURE 9

SEQ ID NO: 1 - Codon-optimised GBA nucleotide sequence from FLF-PL28, without signal peptide portion

GCCAGGCCCTGCATCCCTAAGAGCTTTGGCTACAGCTCTGTGGTGTGTGTGTGCAATGCCACCTAC
 TGTGACAGCTTTGACCCCCCACCTTTCCTGCCCTGGGCACCTTCAGCAGATATGAGAGCACCAGGT
 CTGGGAGGAGGATGGAGCTGAGCATGGGGCCATCCAGGCTAATCACACTGGCACTGGCCTGCTG
 CTGACCCTGCAGCCTGAGCAGAAGTTCCAGAAAGTAAAGGGCTTTGGAGGGGCCATGACTGATGCT
 GCTGCTCTGAACATCCTGGCCCTGAGCCCCCTGCCAGAATCTGCTGCTGAAGAGCTACTTCTCTG
 AGGAGGGCATTGGCTATAACATCATCAGGGTGCCCATGGCCAGCTGTGACTTCAGCATCAGGACCT
 ACACCTATGCTGACACCCTGATGATTTCCAGCTGCACAACTTCAGCCTGCCTGAGGAGGATACCAA
 GCTGAAGATCCCACTGATCCACAGGGCTCTGCAGCTGGCCAGAGGCCTGTGAGCCTGCTGGCCAG
 CCCCTGGACCAGCCCCACTTGGCTGAAGACCAATGGGGCTGTGAATGGGAAGGGGAGCCTGAAGG
 GACAGCCTGGAGACATCTACCACCAGACCTGGGCCAGATACTTTGTGAAGTTCCTGGATGCCTATGC
 TGAGCACAAGCTGCAGTTCTGGGCTGTGACTGCTGAGAATGAGCCTTCTGCTGGGCTGCTGTCTGG
 CTACCCCTTCCAATGCCTGGGCTTCAACCCTGAGCATCAGAGGGACTTCATTGCCAGGGACCTGGG
 CCCTACCCTGGCCAACAGCACTCACCATAATGTTAGGCTGCTGATGCTGGATGACCAGAGGCTGCT
 GCTGCCCCACTGGGCTAAGGTGGTGTGACTGACCCTGAGGCTGCTAAATATGTGCATGGCATTGC
 TGTGCATTGGTACCTGGACTTTCTGGCTCCTGCCAAGGCCACCCTGGGGGAGACCCACAGGCTGTT
 CCCAACACCATGCTGTTTGCCTCTGAGGCCTGTGTGGGCAGCAAGTTCTGGGAGCAGTCTGTGAG
 GCTGGGCAGCTGGGATAGGGGGATGCAGTACAGCCACAGCATCATCACCACCTGCTGTACCATGT
 GGTGGGCTGGACTGACTGGAACCTGGCCCTGAACCCTGAGGGAGGACCTAACTGGGTGAGAACTT
 TGTGGACAGCCCCATCATTGTGGACATCACCAGGACACCTTTTACAAGCAGCCCATGTTCTACCAC
 CTGGGCCACTTCAGCAAGTTCATCCCTGAGGGCAGCCAGAGAGTGGGGCTGGTGGCCAGCCAGAA
 GAATGACCTGGATGCTGTGGCTCTGATGCATCCTGATGGCTCTGCTGTGGTGGTGGTGTGTAACAG
 GAGCTCTAAGGATGTGCCTCTGACCATCAAGGATCCTGCTGTGGGCTTCTGGAGACCATCAGCCC
 TGGCTACAGCATCCACACCTACCTGTGGAGGAGGCAGTGA

SEQ ID NO: 2 - Codon-optimised GBA nucleotide sequence from FLF-PL21, without signal peptide portion

GCCAGGCCCTGTATCCCTAAGAGCTTtGGCTACAGCTCAGTaGtTGTGTCTGTAATGCCACATACTG
 TGACTCCTTtGACCCCCCTACCTTCCCTGCCCTGGGAACCTTCAGCAGaTATGAGTCAACAAGaTCAG
 GAAGGAGGATGGAGCTGTCAATGGGACCCATCCAGGCTAATCACACAGGCACAGGCCTGCTGCTGA
 CCCTGCAGCCAGAACAGAAGTTCCAGAAaGTGAAGGGATTtGGAGGAGCCATGACAGATGCTGCTG
 CTCTCAACATCCTGGCCCTGTCACCCCCTGCCAGAATCTGCTGCTGAAGTCATACTTCTCTGAAGA
 AGGAATtGGATATAACATCATCAGGGTGCCCATGGCCAGCTGTGACTTCTCCATCAGGACCTACACC
 TATGctGACACCCTGATGATTTCCAGCTGCACAACTTCAGCCTCCCAGAGGAAGATACCAAGCTCAA
 GATCCctCTGATaCaTAgGgCaCTGCAGCTGGCCCAGAGGCctGTGTCACTCCTGGCCAGCCCCTGGA
 CATACCCACTTGGCTCAAGACCAATGGAGctGTGAATGGAAAGGGATCACTCAAGGGACAGCctGG
 AGACATCTACCACCAGACCTGGGCCAGaTACTTtGTGAAGTTCCTGGATGCCTATGCTGAGCACAAG
 CTGCAGTTCTGGGCaGTGACAGCTGAAAATGAGCCTTCTGCTGGACTGCTGTCAGGATACCCCTTCC
 AGTGTCTGGGCTTCAACCCTGAACATCAGAGGGACTTCATtGCCAGGGACCTGGGACCTACCCTtGC
 CAACTCAACTACCACAATGTCAGGCTGCTCATGCTGGATGACCAGAGGCTGCTGCTGCCCCACTGG
 GCCAAGGTGGTGTGCTGACAGACCCAGAAGctGCTAAaTATGTGCATGGCATtGCTGTGCATTGGTACC
 TGGACTTCTGGCTCCAGCCAAGGCCACCCTGGGAGAGACACACAGGCTGTTCCCAACACCATGCT
 CTTtGCCTctGAGGCCTGTGTGGGCTCCAAGTTCTGGGAGCAGTCAGTGAGGCTGGGCTCCTGGGA
 TAGGGGAATGCAGTACAGCCACAGCATCATCACAAACCTCCTGTACCATGTGGTgGGCTGGActGAC
 TGGAACCTGGCCCTGAACCctGAAGGAGGACCCAAcTGGGTcagaAAATTTtGTgGACTCACCCATCATt
 GTGGACATACCAAGGACACATTCTACAAGCAGCCCATGTTCTACCACCTGGGCCACTTCAGCAAGT
 TCATCCCTGAGGGCTCCAGAGGGTGGGACTGGTGGCCTCACAGAAGAATGACCTGGATGCaGTGG

CCCTGATGCATCctGATGGCTCTGCTGTGGTGGTtGTGCTGAAtAGaTCCTCTAAGGATGTGCCTCT
GACCATCAAGGATCCTGCTGTGGGCTTCTGAGACAATCTCACCTGGCTACTCCATCCACACCTAC
CTGTGGAGGAGGCAGTGA

SEQ ID NO: 3 - Codon-optimised GBA nucleotide sequence from FLF-PL30, without signal peptide portion

GCCAGGCCCTGCATCCCTAAGAGCTTTGGCTACAGCTCTGTGGTGTGTGTGTGCAATGCCACATAC
TGTGACTCCTTTGACCCCCCACCTTCTGCCCCTGGGCACaTTctccAGaTATGAGAGCACAAAGATC
TGGGAGAAGGATGGAGCTGAGCATGGGGCCCATCCAGGCTAATCACACTGGCACAGGCCTGCTGCT
GACCCTGCAGCCTGAACAGAAGTTTCAGAAaGTGAAGGGATTTGGAGGGGCCATGACAGATGCTGC
TGCTCTGAATATCCTGGCCCTGTACCCCCCTGCCAGAATCTGCTGCTGAAGAGCTACTTTTCAGAA
GAAGGAATTGGATATAATATCATCAGAGTGCCCATGGCCAGCTGTGACTTTTCCATCAGAACCTACA
CCTATGCAGACACCCCTGATGATTTTCAGCTGCACAATTTTAGCCTGCCTGAGGAAGATACCAAGCT
GAAGATACCCCTGATTCACAGGGCCCTGCAGCTGGCCAGAGGCCTGTTTCACTGCTGGCCAGCCC
CTGGACATCACCCACCTGGCTGAAGACCAATGGAGCTGTGAATGGGAAGGGGTCACTGAAGGGACA
GCCTGGAGACATCTACCACCAGACCTGGGCCAGATACTTTGTGAAGTTTCTGGATGCCTATGCTGA
GCACAAGCTGCAGTTTTGGGCAGTGACAGCTGAAAATGAGCCTTCAGCTGGGCTGCTGTCAGGATA
CCCCTTTCAGTGCCTGGGCTTTACCCCTGAACATCAGAGGGACTTTATTGCCAGGGACCTGGGCCCT
ACCCTGGCCAATAGCACCCAcCAtAATGTgAggttGCTGATGCTGGATGACCAGAGGCTGCTGCTGCC
CCACTGGGCAAAGGTGGTGTGCTGACAGACCCCTGAAGCAGCTAAaTATGTTTCATGGCATTGCTGTGCA
TTGGTACCTGGACTTTCTGGCTCCTGCCAAGGCCACCCTGGGGGAGACACACAGGCTGTTTCCCAA
TACCATGCTGTTTGCCTctGAGGCCTGTGTGGGCTCCAAGTTTTGGGAGCAGTCTGTGAGGCTGGG
CTCCTGGGATAGAGGGATGCAGTACAGCCACAGCATCATACCAATCTGCTGTACCATGTGGTGGG
CTGGACTGACTGGAATCTGGCCCTGAATCCTGAAGGAGGACctAAcTGGGTcAGgAATTTTGTGGAC
AGCCCCATCATTGTGGACATACCAAGGACACCTTTTACAAGCAGCCCATGTTTTACCACCTGGGCC
ACTTTAGCAAGTTTATCCTGAGGGCTCCAGAGAGTGGGGCTGTTGCCAGCCAGAAGAATGACC
TGGATGCAGTGGCACTGATGCATCCTGATGGCTCAGCTGTTGTGGTGGTGTGAATAGATCCAGCA
AGGATGTGCCTCTGACCATCAAGGATCCTGCTGTGGGCTTTCTGGAGACAATCTCACCTGGCTACTC
CATTACACCTACCTGTGGAGAAGGCAGTGA

SEQ ID NO: 4 - Codon-optimised GBA nucleotide sequence from FLF-PL36, without signal peptide portion

GCCAGGCCTTGCATCCCAAAGTCTTTTCGGCTACAGCTCCGTGGTGTGCGTGTGCAACGCCACCTATT
GTGACTCCTTCGATCCCCCTACCTTTCCCGCCCTGGGCACATTTTCTAGATACGAGTCTACACGCAG
CGGCCGAGAATGGAGCTGAGCATGGGCCCTATCCAGGCCAATCACACAGGAACAGGCCTGCTGCT
GACCCTGCAGCCAGAGCAGAAGTTCAGAAGGTGAAGGGCTTTGGCGGAGCCATGACAGATGCAGC
CGCCCTGAACATCCTGGCCCTGTCCCCACCCGCCAGAATCTGCTGCTGAAGTCTACTTCTCTGAG
GAGGGCATCGGCTATAACATCATCCGGGTGCCATGGCCAGCTGCGACTTTTCCATCAGAACCTACA
CATATGCCGATACCCCTGACGATTTCCAGCTGCACAATTTTTCCCTGCCAGAGGAGGATACAAAGCT
GAAGATCCCCCTGATTCACCGGGCCCTGCAGCTGGCACAGCGGCCCTGAGCCTGCTGGCCAGCCC
CTGGACCTCCCCTACATGGCTGAAGACCAACGGCGCCGTGAATGGCAAGGGCTCTCTGAAGGGACA
GCCTGGCGACATCTACCACCAGACATGGGCCAGATAATTCGTGAAGTTTCTGGATGCCTACGCCGA
GCACAAGCTGCAGTTCTGGGCCGTGACAGCAGAGAATGAGCCTTCTGCCGGCCTGCTGAGCGGCTA
TCCCTTCCAGTGCCTGGGCTTTACACCTGAGCACCAGCGGGACTTTATCGCCAGAGATCTGGGCCC
AACCTGGCCAACCTCCACACACCACAATGTGAGGCTGCTGATGCTGGACGATCAGCGCCTGCTGCT
GCCTCACTGGGCCAAGGTGGTGTGCTGACCGACCCAGAGGCCCGCAAGTACGTGCACGGCATCGCCGT
GCACTGGTATCTGGATTTCTGGCACCTGCAAAGGCCACCCTGGGAGAGACACACCGGCTGTTCCC
TAACACCATGCTGTTTGGCAGCGAGGCCTGCGTGGGCTCCAAGTTTTGGGAGCAGTCCGTGAGGCT
GGGATCTTGGGACAGAGGCATGCAGTACTCCACTCTATCATACCAATCTGCTGTATCACGTGGTG
GGCTGGACAGACTGGAACCTGGCCCTGAATCCAGAGGGCGGCCCAACTGGGTGAGAAATTTCTGTG
GATAGCCCCATCATCGTGGACATACCAAGGATACATTCTACAAGCAGCCAATGTTTTATCACCTGG
GCCACTTCTCTAAGTTTATCCCTGAGGGCAGCCAGAGGGTGGGCCTGGTGGCCAGCCAGAAGAAGC

ACCTGGATGCCGTGGCCCTGATGCACCCTGATGGCTCCGCCGTGGTGGTGGTGGTGAATCGCTCTA
GCAAGGACGTGCCTCTGACCATCAAGGATCCAGCCGTGGGATTTCTGGAGACTATTTACCTGGCT
ATTC AATTCATACCTACCTGTGGAGGAGGCAGTGA

SEQ ID NO: 5 - Codon-optimised GBA nucleotide sequence from FLF-PL28, with signal peptide portion

ATGGAGTTTTCAAGTCCTTCCAGAGAGGAATGTCCCAAGCCTTTGAGTAGGGTAAGCATCATGGCT
GGCAGCCTCACAGGATTGCTTCTACTTCAGGCAGTGTCTGTGGGCATCAGGTGCCAGGCCCTGCATC
CCTAAGAGCTTTGGCTACAGCTCTGTGGTGTGTGTGTGCAATGCCACCTACTGTGACAGCTTTGAC
CCCCCACCTTTCTGCCCTGGGCACCTTCAGCAGaTATGAGAGCACCAGGTCTGGGAGGAGGATG
GAGCTGAGCATGGGGCCCATCCAGGCTAATCACACTGGCACTGGCCTGCTGCTGACCCTGCAGCCT
GAGCAGAAGTTCCAGAAaGTaAAGGGCTTTGGAGGGGCCATGACTGATGCTGCTGCTCTGAACATC
CTGGCCCTGAGCCCCCTGCCAGAATCTGCTGCTGAAGAGCTACTTCTCTGAGGAGGGCATTGGC
TATAACATCATCAGGGTGCCCATGGCCAGCTGTGACTTCAGCATCAGGACCTACACCTATGCTGACA
CCCCTGATGATTTCCAGCTGCACAACCTTCAGCCTGCCTGAGGAGGATACCAAGCTGAAGATCCCCT
GATCCACAGGGctCTGCAGCTGGCCAGAGGCCTGTGAGCCTGCTGGCCAGCCCCTGGACCAGCCC
CACTTGGCTGAAGACCAATGGGGCTGTGAATGGGAAGGGGAGCCTGAAGGGACAGCCTGGAGACA
TCTACCACCAGACCTGGGCCAGATACTTTGTGAAGTTCCTGGATGCCTATGCTGAGCACAAGCTGCA
GTTCTGGGCTGTGACTGCTGAGAATGAGCCTTCTGCTGGGCTGCTGTCTGGCTACCCCTTCCAaTG
CCTGGGCTTACCCCTGAGCATCAGAGGGACTTCATTGCCAGGGACCTGGGCCCTACCCTGGCCAA
CAGCACTCACCAaATGTtAGGCTGCTGATGCTGGATGACCAGAGGCTGCTGCTGCCCCACTGGGCT
AAGGTGGTGTGACTGACCCTGAGGCTGCTAAaTATGTGCATGGCATTGCTGTGCATTGGTACCTG
GACTTTCTGGCTCCTGCCAAGGCCACCCTGGGGGAGACCCACAGGCTGTTCCCAACACCATGCTG
TTTGCCTCTGAGGCCTGTGTGGGCAGCAAGTTCCTGGGAGCAGTCTGTGAGGCTGGGCAGCTGGGA
TAGGGGGATGCAGTACAGCCACAGCATCATACCAACCTGCTGTACCATGTGGTGGGCTGGACTGA
CTGGAACCTGGCCCTGAACCCTGAGGGAGGACctAaTGGGTcAGaAACTTTGTGGACAGCCCCATC
ATTGTGGACATACCAAGGACACCTTTTACAAGCAGCCCATGTTCTACCACCTGGGCCACTTCAGCA
AGTTCATCCCTGAGGGCAGCCAGAGAGTGGGGCTGGTGGCCAGCCAGAAGAATGACCTGGATGCT
GTGGCTCTGATGCATCCTGATGGCTCTGCTGTGGTGGTGGTGGTGAACAGGAGCTCTAAGGATGTG
CCTCTGACCATCAAGGATCCTGCTGTGGGCTTCTGGAGACCATCAGCCCTGGCTACAGCATCCACA
CCTACCTGTGGAGGAGGCAGTGA

SEQ ID NO: 6 - Codon-optimised GBA nucleotide sequence from FLF-PL21, with signal peptide portion

ATGGAGTTTTCAAGTCCTTCCAGAGAGGAATGTCCCAAGCCTTTGAGTAGGGTAAGCATCATGGCT
GGCAGCCTCACAGGATTGCTTCTACTTCAGGCAGTGTCTGTGGGCATCAGGTGCCAGGCCCTGTATC
CCTAAGAGCTTTGGCTACAGCTCAGTaGTtTGTGTCTGTAATGCCACATACTGTGACTCCTTtGACCC
CCCTACCTTCCCTGCCCTGGGAACCTTCAGCAGaTATGAGTCAACAAGaTCAGGAAGGAGGATGGAG
CTGTCAATGGGACCCATCCAGGCTAATCACACAGGCACAGGCCTGCTGCTGACCCTGCAGCCAGAAC
AGAAGTTCAGAAaGTGAAGGGATTtGGAGGAGCCATGACAGATGCTGCTGCTCTCAACATCCTGGC
CCTGTCACCCCCCTGCCAGAATCTGCTGCTGAAGTCATACTTCTCTGAAGAAGGAATtGGATATAAC
ATCATCAGGGTGCCCATGGCCAGCTGTGACTTCTCCATCAGGACCTACACCTATGctGACACCCCTG
ATGATTTCCAGCTGCACAACCTTCAGCCTCCCAGAGGAAGATACCAAGCTCAAGATCCCtCTGATaCat
AGgGCaCTGCAGCTGGCCAGAGGCctGTGTCACTCCTGGCCAGCCCCTGGACATCACCCACTTGGC
TCAAGACCAATGGAGctGTGAATGGAAAGGGATCACTCAAGGGACAGCctGGAGACATCTACCACCA
GACCTGGGCCAGaTACTTtGTGAAGTTCCTGGATGCCTATGCTGAGCACAAGCTGCAGTTCTGGGCa
GTGACAGCTGAAAATGAGCCTTCTGCTGGACTGCTGTGAGGATACCCCTTCCAGTGTCTGGGCTTC
ACCCCTGAACATCAGAGGGACTTCATtGCCAGGGACCTGGGACCTACCCTtGCCAACTCAACTCACCA
CAATGTGAGGCTGCTCATGCTGGATGACCAGAGGCTGCTGCTGCCCCACTGGGCCAAGGTGGTGTGCT
GACAGACCCAGAAGctGCTAAaTATGTGCATGGCATtGCTGTGCATTGGTACCTGGACTTCTGGCT
CCAGCCAAGGCCACCCTGGGAGAGACACAGGCTGTTCCCAACACCATGCTCTTtGCCTctGAGG
CCTGTGTGGGCTCCAAGTTCCTGGGAGCAGTCACTGAGGCTGGGCTCCTGGGATAGGGGAATGCAG

TACAGCCACAGCATCATCACAAACCTCCTGTACCATGTGGTgGGCTGGACTgACTGGAACCTGGCCC
 TGAACCCtGAAGGAGGACCCAAcTGGGTcagaAAtTTtGTgGACTCACCCATCATtGTGGACATCACCA
 AGGACACATTCTACAAGCAGCCCATGTTCTACCACCTGGGCCACTTCAGCAAGTTCATCCCTGAGGG
 CTCCCAGAGGGTGGGACTGGTGGCCTCACAGAAGAAtGACCTGGAtGCaGTGGCCCTGATGCATCCT
 GATGGCTCTGCTGTGGTGGTtGTGCTGAAtAGaTCCTCTAAGGATGTGCCTCTGACCATCAAGGATC
 CTGCTGTGGGCTTCTGGAGACAATCTCACCTGGCTACTCCATCCACACCTACCTGTGGAGGAGGC
 AGTGA

SEQ ID NO: 7 - Codon-optimised GBA nucleotide sequence from FLF-PL30, with signal peptide portion

ATGGAGTTTTCAAGTCCTTCCAGAGAGGAATGTCCCAAGCCTTTGAGTAGGGTAAGCATCATGGCT
 GGCAGCCTCACAGGATTGCTTCTACTTCAGGCAGTGTCTGGGCATCAGGTGCCAGGCCCTGCATC
 CCTAAGAGCTTTGGCTACAGCTCTGTGGTGTGTGTGCAATGCCACATACTGTGACTCCTTTGACC
 CCCCCACCTTCTGCCCTGGGCACaTTctccAGaTATGAGAGCACAAGATCTGGGAGAAGGATGGA
 GCTGAGCATGGGGCCCATCCAGGCTAATCACACTGGCACAGGCCTGCTGCTGACCCTGCAGCCTGA
 ACAGAAGTTTCAGAAaGTGAAGGGATTTGGAGGGGCCATGACAGATGCTGCTGCTCTGAATATCCT
 GGCCCTGTCACCCCTGCCAGAATCTGCTGCTGAAGAGCTACTTTTCAGAAGAAGGAATTGGATAT
 AATATCATCAGAGTGCCCATGGCCAGCTGTGACTTTTCCATCAGAACCTACACCTATGCAGACACCC
 CTGATGATTTTCAGCTGCACAATTTTAGCCTGCCTGAGGAAGATACCAAGCTGAAGATACCCCTGAT
 TCACAGGGCCCTGCAGCTGGCCCAGAGGCCTGTTTCACTGCTGGCCAGCCCCTGGACATCACCCAC
 CTGGCTGAAGACCAATGGAGCTGTGAATGGGAAGGGGTCACTGAAGGGACAGCCTGGAGACATCTA
 CCACCAGACCTGGGCCAGATACTTTGTGAAGTTTCTGGATGCCTATGCTGAGCACAAGCTGCAGTTT
 TGGGCAGTGACAGCTGAAAATGAGCCTTCAGCTGGGCTGCTGTCAGGATACCCCTTTCAGTGCCTG
 GGCTTTACCCCTGAACATCAGAGGGACTTTATTGCCAGGGACCTGGGCCCTACCCTGGCCAATAGC
 ACCCAcCAtAATGTgAGgttgCTGATGCTGGATGACCAGAGGCTGCTGCTGCCCCACTGGGCAAAGGT
 GGTGCTGACAGACCCTGAAGCAGCTAAaTATGTTTATGGCATTGCTGTGCATTGGTACCTGGACTTT
 CTGGCTCCTGCCAAGGCCACCCTGGGGGAGACACACAGGCTGTTTCCAATACCATGCTGTTTGCC
 TctGAGGCCTGTGTGGCTCCAAGTTTTGGGAGCAGTCTGTGAGGCTGGGCTCCTGGGATAGAGG
 GATGCAGTACAGCCACAGCATCATCACCAATCTGCTGTACCATGTGGTGGGCTGGACTGACTGGAA
 TCTGGCCCTGAATCCTGAAGGAGGACcAAcTGGGTcAGaATTTTGTGGACAGCCCCATCATTGTG
 GACATCACCAAGGACACCTTTTACAAGCAGCCATGTTTTACCACCTGGGCCACTTTAGCAAGTTTA
 TTCCTGAGGGCTCCAGAGAGTGGGGCTGTTGCCAGCCAGAAGAATGACCTGGATGCAGTGGCAG
 TGATGCATCCTGATGGCTCAGCTGTTGTGGTGGTGTGCTGAATAGATCCAGCAAGGATGTGCCTCTGA
 CCATCAAGGATCCTGCTGTGGGCTTCTGGAGACAATCTCACCTGGCTACTCCATTACACCTACCT
 GTGGAGAAGGCAGTGA

SEQ ID NO: 8 - Codon-optimised GBA nucleotide sequence from FLF-PL36, with signal peptide portion

ATGGAGTTTTCAAGTCCTTCCAGAGAGGAATGTCCCAAGCCTTTGAGTAGGGTAAGCATCATGGCT
 GGCAGCCTCACAGGATTGCTTCTACTTCAGGCAGTGTCTGGGCATCAGGTGCCAGGCCCTTGCATC
 CCAAAGTCTTTCCGGCTACAGCTCCGTGGTGTGCGTGTGCAACGCCACCTATTGTGACTCCTTCGATC
 CCCCTACCTTTCCCGCCCTGGGCACATTTTCTAGATACGAGTCTACACGCAGCGGCCGGAGAATGGA
 GCTGAGCATGGGCCCTATCCAGGCCAATCACACAGGAACAGGCCTGCTGCTGACCCTGCAGCCAGA
 GCAGAAGTTCCAGAAGGTGAAGGGCTTTGGCGGAGCCATGACAGATGCAGCCGCCCTGAACATCCT
 GGCCCTGTCCCACCCGCCAGAATCTGCTGCTGAAGTCTACTTCTCTGAGGAGGGCATCGGCTA
 TAACATCATCCGGGTGCCATGGCCAGCTGCGACTTTTCCATCAGAACCTACACATATGCCGATACC
 CCTGACGATTTCCAGCTGCACAATTTTTCCCTGCCAGAGGAGGATACAAAGCTGAAGATCCCCCTGA
 TTCACCGGGCCCTGCAGCTGGCACAGCGGCCCGTGAGCCTGCTGGCCAGCCCCTGGACCTCCCCTA
 CATGGCTGAAGACCAACGGCGCCGTGAATGGCAAGGGCTCTCTGAAGGGACAGCCTGGCGACATCT
 ACCACCAGACATGGGCCAGATATTTCTGAAGTTTCTGGATGCCTACGCCGAGCACAAGCTGCAGTT
 CTGGGCCGTGACAGCAGAGAATGAGCCTTCTGCCGGCCTGCTGAGCGGCTATCCCTTCCAGTGCCT
 GGGCTTTACACCTGAGCACCAGCGGGACTTTATCGCCAGAGATCTGGGCCCAACCCTGGCCAACTC

CACACACCACAATGTGAGGCTGCTGATGCTGGACGATCAGCGCCTGCTGCTGCCTCACTGGGCCAA
GGTGGTGCTGACCGACCCAGAGGCCGCAAGTACGTGCACGGCATCGCCGTGCACTGGTATCTGGA
TTTCCTGGCACCTGCAAAGGCCACCCTGGGAGAGACACACCGGCTGTTCCCTAACACCATGCTGTTT
GCCAGCGAGGCCTGCGTGGGCTCCAAGTTTTGGGAGCAGTCCGTGAGGCTGGGATCTTGGGACAG
AGGCATGCAGTACTCCCACTCTATCATACCAATCTGCTGTATCACGTGGTGGGCTGGACAGACTGG
AACCTGGCCCTGAATCCAGAGGGCGGCCCAACTGGGTGAGAAATTCGTGGATAGCCCCATCATC
GTGGACATCACCAAGGATACATTCTACAAGCAGCCAATGTTTTATCACCTGGGCCACTTCTCTAAGT
TTATCCCTGAGGGCAGCCAGAGGGTGGGCCTGGTGGCCAGCCAGAAGAACGACCTGGATGCCGTG
GCCCTGATGCACCCTGATGGCTCCGCCGTGGTGGTGGTGTGCTGAATCGCTCTAGCAAGGACGTGCCT
CTGACCATCAAGGATCCAGCCGTGGGATTTCTGGAGACTATTTACCTGGCTATTCAATTCATACCT
ACCTGTGGAGGAGGCAGTGA

SEQ ID NO: 9 - Wild type human GBA nucleotide sequence with signal peptide (from
GenBank NM_000157.3)

ATGGAGTTTTCAAGTCCTTCCAGAGAGGAATGTCCAAGCCTTTGAGTAGGGTAAGCATCATGGCT
GGCAGCCTCACAGGATTGCTTCTACTTCAGGCAGTGTGCGTGGGCATCAGGTGCCCCGCCCTGCATC
CCTAAAAGCTTCGGCTACAGCTCGGTGGTGTGTGTCTGCAATGCCACATACTGTGACTCCTTTGACC
CCCCGACCTTTCCTGCCCTTGGTACCTTCAGCCGCTATGAGAGTACACGCAGTGGGCGACGGATGG
AGCTGAGTATGGGGCCCATCCAGGCTAATCACACGGGCACAGGCCTGCTACTGACCCTGCAGCCAG
AACAGAAGTTCAGAAAGTGAAGGGATTTGGAGGGGCCATGACAGATGCTGCTGCTCTCAACATCC
TTGCCCTGTCACCCCTGCCAAAATTTGCTACTTAAATCGTACTTCTCTGAAGAAGGAATCGGATA
TAACATCATCCGGGTACCCATGGCCAGCTGTGACTTCTCCATCCGCACCTACACCTATGCAGACACC
CCTGATGATTTCCAGTTGCACAACCTCAGCCTCCAGAGGAAGATACCAAGCTCAAGATACCCCTGA
TTCACCGAGCCCTGCAGTTGGCCAGCGTCCCGTTTTACTCCTTGCCAGCCCCTGGACATCACCCAC
TTGGCTCAAGACCAATGGAGCGGTGAATGGGAAGGGGTCACTCAAGGGACAGCCCGGAGACATCTA
CCACCAGACCTGGGCCAGATACTTTGTGAAGTTCCTGGATGCCTATGCTGAGCACAAGTTACAGTTC
TGGGCAGTGACAGCTGAAAATGAGCCTTCTGCTGGGCTGTTGAGTGGATACCCCTTCCAGTGCCTG
GGCTTACCCCTGAACATCAGCGAGACTTCATTGCCCGTGACCTAGGTCTACCCTCGCCAACAGTA
CTCACCACAATGTCCGCCTACTCATGCTGGATGACCAACGCTTGCTGCTGCCCACTGGGCAAAGGT
GGTACTGACAGACCCAGAAGCAGCTAAATATGTTTCATGGCATTGCTGTACATTGGTACCTGGACTTT
CTGGCTCCAGCCAAAGCCACCCTAGGGGAGACACACCGCCTGTTCCCCAACACCATGCTCTTTGCCT
CAGAGGCCTGTGTGGGCTCCAAGTTCTGGGAGCAGAGTGTGCGGCTAGGCTCCTGGGATCGAGGG
ATGCAGTACAGCCACAGCATCATCAGAACCTCCTGTACCATGTGGTTCGGCTGGACCGACTGGAACC
TTGCCCTGAACCCCGAAGGAGGACCCAATTGGGTGCGTAACTTTGTCGACAGTCCCATCATTGTAGA
CATACCAAGGACACGTTTTACAACAGCCCATGTTCTACCACCTTGGCCACTTCAGCAAGTTCATTCT
CTGAGGGCTCCAGAGAGTGGGGCTGGTTGCCAGTCAGAAGAACGACCTGGACGCAGTGGCACTG
ATGCATCCCGATGGCTCTGCTGTTGTGGTTCGTGCTAAACCGCTCCTCTAAGGATGTGCCTCTTACCA
TCAAGGATCCTGCTGTGGGCTTCTGGAGACAATCTCACCTGGCTACTCCATTACACCTACCTGTG
GCGTCGCCAGTGA

SEQ ID NO: 10 - LSP-S transcription regulatory element

CCCTAAAATGGGCAAACATTGCAAGCAGCAAACAGCAAACACACAGCCCTCCCTGCCTGCTGACCTT
GGAGCTGGGGCAGAGGTCAGACACCTCTCTGGGCCCATGCCACCTCCAAGTGGACACAGGACGCTG
TGGTTTCTGAGCCAGGGGGCGACTCAGATCCAGCCAGTGGACTTAGCCCTGTTTGTCTCTCCGA
TAACTGGGGTGACCTTGGTTAATATTCACCAGCAGCCTCCCCGTTGCCCTCTGGATCCACTGCTT
AAATACGGACGAGGACAGGGCCCTGTCTCCTCAGCTTCAGGCACCACCACTGACCTGGGACAGTGA
AT

SEQ ID NO: 11 - HCR enhancer portion of LSP-S

CCCTAAAATGGGCAAACATTGCAAGCAGCAAACAGCAAACACACAGCCCTCCCTGCCTGCTGACCTT
GGAGCTGGGGCAGAGGTCAGACACCTCTCTGGGCCCATGCCACCTCCAAC

SEQ ID NO: 12 - A1AT promoter portion of LSP-S

GGGCGACTCAGATCCCAGCCAGTGGACTTAGCCCCTGTTTGCTCCTCCGATAACTGGGGTGACCTT
GGTTAATATTACACCAGCAGCCTCCCCCGTTGCCCTCTGGATCCACTGCTTAAATACGGACGAGGAC
AGGGCCCTGTCTCCTCAGCTTCAGGCACCACCACTGACCTGGGACAGTGAAT

SEQ ID NO: 13 - CAG promoter

GACATTGATTATTGACTAGTTATTAATAGTAATCAATTACGGGGTCATTAGTTCATAGCCCATATATG
GAGTTCCGCGTTACATAACTTACGGTAAATGGCCCGCCTGGCTGACCGCCCAACGACCCCCGCCCAT
TGACGTCAATAATGACGTATGTTCCCATAGTAACGCCAATAGGGACTTTCCATTGACGTCAATGGGT
GGAGTATTTACGGTAAACTGCCACTTGGCAGTACATCAAGTGTATCATATGCCAAGTACGCCCCCT
ATTGACGTCAATGACGGTAAATGGCCCGCCTGGCATTATGCCCAGTACATGACCTTATGGGACTTTC
CTACTTGGCAGTACATCTACGTATTAGTCATCGCTATTACCATGGTCGAGGTGAGCCCCACGTTCTG
CTTCACTCTCCCCATCTCCCCCCCCCTCCCCACCCCAATTTTGTATTTATTTATTTTTTAATTTTTG
TGCAGCGATGGGGGCGGGGGGGGGGGGGGGGGCGCGCGCCAGGCGGGGCGGGGCGGGGCGAGG
GGCGGGGCGGGGCGAGGCGGAGAGGTGCGGCGGCAGCCAATCAGAGCGGCGCGCTCCGAAAGTT
TCCTTTTATGGCGAGGCGGCGGCGGCGGCCCTATAAAAAGCGAAGCGCGCGGGCGG

SEQ ID NO: 14 - LSP-L transcription regulatory element

AGGCTCAGAGGCACACAGGAGTTTCTGGGCTCACCCCTGCCCCCTTCCAACCCCTCAGTTCCCATCCT
CCAGCAGCTGTTTGTGTGCTGCCTCTGAAGTCCACACTGAACAACTTCAGCCTACTCATGTCCCTA
AAATGGGCAAACATTGCAAGCAGCAAACAGCAAACACACAGCCCTCCCTGCCTGCTGACCTTGGAGC
TGGGGCAGAGGTCAGAGACCTCTCTGGGCCCATGCCACCTCCAACATCCACTCGACCCCTTGAATT
TCGGTGGAGAGGAGCAGAGGTTGTCTGGCGTGTTTAGGTAGTGTGAGAGGGGTACCCGGGGAT
CTTGCTACCAGTGGAACAGCCACTAAGGATTCTGCAGTGAGAGCAGAGGGCCAGCTAAGTGGTACT
CTCCAGAGACTGTCTGACTCACGCCACCCCTCCACCTTGGACACAGGACGCTGTGGTTTCTGAGC
CAGGTACAATGACTCCTTTTCGGTAAGTGCAGTGGAAGCTGTACACTGCCAGGCAAAGCGTCCGGG
CAGCGTAGGCGGGCGACTCAGATCCCAGCCAGTGGACTTAGCCCCTGTTTGCTCCTCCGATAACTG
GGGTGACCTTGGTTAATATTACACCAGCAGCCTCCCCCGTTGCCCTCTGGATCCACTGCTTAAATAC
GGACGAGGACAGGGCCCTGTCTCCTCAGCTTCAGGCACCACCACTGACCTGGGACAGTGAATGATC
CCCCGATCTGCGGCC

SEQ ID NO: 15 - A1AT promoter portion of LSP-L

GGATCTTGCTACCAGTGGAAACAGCCACTAAGGATTCTGCAGTGAGAGCAGAGGGCCAGCTAAGTGG
TACTCTCCAGAGACTGTCTGACTCACGCCACCCCTCCACCTTGGACACAGGACGCTGTGGTTTCT
GAGCCAGGTACAATGACTCCTTTTCGGTAAGTGCAGTGGAAGCTGTACACTGCCAGGCAAAGCGTC
CGGGCAGCGTAGGCGGGCGACTCAGATCCCAGCCAGTGGACTTAGCCCCTGTTTGCTCCTCCGATA
ACTGGGGTGACCTTGGTTAATATTACACCAGCAGCCTCCCCCGTTGCCCTCTGGATCCACTGCTTAA
ATACGGACGAGGACAGGGCCCTGTCTCCTCAGCTTCAGGCACCACCACTGACCTGGGACAGTGAAT
GATCCCCCTGATCTGCGGCC

SEQ ID NO: 16 - HCR enhancer portion of LSP-L

AGGCTCAGAGGCACACAGGAGTTTCTGGGCTCACCCCTGCCCCCTTCCAACCCCTCAGTTCCCATCCT
CCAGCAGCTGTTTGTGTGCTGCCTCTGAAGTCCACACTGAACAACTTCAGCCTACTCATGTCCCTA
AAATGGGCAAACATTGCAAGCAGCAAACAGCAAACACACAGCCCTCCCTGCCTGCTGACCTTGGAGC
TGGGGCAGAGGTCAGAGACCTCTCTGGGCCCATGCCACCTCCAACATCCACTCGACCCCTTGAATT
TCGGTGGAGAGGAGCAGAGGTTGTCTGGCGTGTTTAGGTAGTGTGAGAGGG

SEQ ID NO: 17 - Wild type GBA nucleotide sequence corresponding to signal peptide

ATGGAGTTTTCAAGTCCTTCCAGAGAGGAATGTCCCAAGCCTTTGAGTAGGGTAAGCATCATGGCT
GGCAGCCTCACAGGATTGCTTCTACTTCAGGCAGTGTCTGGGCATCAGGT

SEQ ID NO: 18 - Wild type GCase polypeptide sequence of signal peptide

MEFSSPSREECPKPLSRVSIIMAGSLTGLLLLQAVSWASG

SEQ ID NO: 19 - Polypeptide sequence of liver-tropic capsid

MAADGYLPDWLEDNLSEGIREWWALKPGVPPKANQQHQDNRRGLVLPGYKYLPGNGLDKGEPVNEA
DAAALEHDKAYDQQLKAGDNPYLKYNHADADEFQERLQEDTSFGGNLGRAVFQAKKRILEPLGLVEEAAKT
APGKKRPVDQSPQEPDSSSGVGKSGKQPARKRLNFGQTGDSESVDPQPLGEPPAAPTSLGSNTMASGGG
APMADNNEGADGVGNSSGNWHCDSQWLGDRVITSTRTWALPTYNNHLYKQISSQSGASNDNHYFGYST
PWGYFDFNRFHCHFSRWDQRLINNNWGFPRPKLSFKLFNIQVKEVTQNDGTTTIANNLTSTVQVFTDSE
YQLPYVLSAHQGLPPFPADVFMVPQYGYLTLNNGSQAVGRSSFYCLEYFPSQMLRTGNNFQFSYTFED
VPFHSSYAHSQSLDRLMNPLIDQYLYLNRTQGTTSGTTNQSRLLFSQAGPQMSLQARNWLPGPCYRQQ
RLSKTANDNNNSNFPWTAASKYHLNGRDSL VNP GPAMASHKDDEEKFFPMHG NLI FGKEGTTASNAELDN
VMITDEEEIRTTNPVATEQYGTVANLQSSNTAPTRTVNDQGALPGMVWQDRDVYLQGPWAKIPHTD
GHFHPSPLMGGFGLKHPPPQIMIKNTPVANPPTTFSPA KFAFITQYSTGQVSVEIEWELQKENS KRWN
EIQYTSNYNKS VNVDFTVDTNGVYSEPRPIGTRYLTRNL

SEQ ID NO: 20 - Polypeptide sequence of liver-tropic capsid

MAADGYLPDWLEDNLSEGIREWWALKPGAPKPKANQQKQDDGRGLVLPGYKYLGPFNGLDKGEPVNA
DAAALEHDKAYDQQLQAGDNPYLRYNHADADEFQERLQEDTSFGGNLGRAVFQAKKRILEPLGLVEEGAK
TAPGKKRPVDQSPQEPDSSSGVGKSGKQPARKRLNFGQTGDSESVDPQPLGEPPAAPTSLGSNTMASGG
GAPMADNNEGADGVGNSSGNWHCDSQWLGDRVITSTRTWALPTYNNHLYKQISSQSGASNDNHYFGY
STPWGYFDFNRFHCHFSRWDQRLINNNWGFPRPKLSFKLFNIQVKEVTQNDGTTTIANNLTSTVQVFTD
SEYQLPYVLSAHQGLPPFPADVFMVPQYGYLTLNNGSQAVGRSSFYCLEYFPSQMLRTGNNFQFSYTF
EDVPFHSSYAHSQSLDRLMNPLIDQYLYLNRTQGTTSGTTNQSRLLFSQAGPQMSLQARNWLPGPCYR
QQRLSKTANDNNNSNFPWTAASKYHLNGRDSL VNP GPAMASHKDDEEKFFPMHG NLI FGKEGTTASNAEL
DNVMITDEEEIRTTNPVATEQYGTVANLQSSNTAPTRTVNDQGALPGMVWQDRDVYLQGPWAKIPHT
DGHFHPSPLMGGFGLKHPPPQIMIKNTPVANPPTTFSPA KFAFITQYSTGQVSVEIEWELQKENS KRWN
PEIQYTSNYNKS VNVDFTVDTNGVYSEPRPIGTRYLTRNL

SEQ ID NO: 21 - Polypeptide sequence of CNS-tropic capsid

MAADGYLPDWLEDNLSEGIREWWALKPGAPQPKANQQHQDNARGLVLPGYKYLPGNGLDKGEPVNA
DAAALEHDKAYDQQLKAGDNPYLKYNHADADEFQERLKEDTSFGGNLGRAVFQAKKRILLEPLGLVEEAAKT
APGKKRPVEQSPQEPDSSAGIGKSGAQPAKKRLNFGQTGDTE SVDPQP IGEPPAAPSGVGS LTMASGGG
APVADNNEGADGVGSSSGNWHCDSQWLGDRVITSTRTWALPTYNNHLYKQISNSTSGGSSNDNAYFGY
STPWGYFDFNRFHCHFSRWDQRLINNNWGFPRKRLNFKLFNIQVKEVTDNNGVKTIANNLTSTVQVFTD
SDYQLPYVLSAHEGCLPPFPADVFMIPQYGYLTLNDGSQAVGRSSFYCLEYFPSQMLRTGNNFQFSYEF
NVPFHSSYAHSQSLDRLMNPLIDQYLYLSKTINGSGQNQQTLKFSVAGPSNMAVQGRNYIPGPSYRQQRV
STTVTQNNNSEFAWPGASSWALNGRNSLMNPGPAMASHKEGEDRFFPLSGSLIFGKQGTGRDNVDADKV
MITNEEEIKTTNPVATESYGVATNHQSAQAQAQTGWVQNGILPGMVWQDRDVYLQGPWAKIPHTDG
NFHPSPLMGGFGMKHPPPQILIKNTPVADPPTAFNKDKLNSFITQYSTGQVSVEIEWELQKENS KRWN
QYTSNYYKSNNVEFAVNTEGVYSEPRPIGTRYLTRNL

SEQ ID NO: 22 - Nucleotide sequence of SV40 intron

GTAAATATAAAATTTTTAAGTGTATAATGTGTAAACTACTGATTCTAATTGTTTCTCTCTTTTAG

SEQ ID NO: 23 - Nucleotide sequence of bovine growth hormone poly A sequence

CTGTGCCTTCTAGTTGCCAGCCATCTGTTGTTTGCCCCTCCCCCGTGCCTTCCTTGACCCTGGAAGG
TGCCACTCCCACTGTCCTTTCCTAATAAAATGAGGAAATTGCATCGCATTGTCTGAGTAGGTGTCAT
TCTATTCTGGGGGGTGGGGTGGGGCAGGACAGCAAGGGGGAGGATTGGGAAGACAATAGCAGGCA
TGCTGGGGA

SEQ ID NO: 24 - Polypeptide sequence of liver-tropic capsid

MAADGYLPDWLEDNLSEGIREWWALQPGAPKPKANQQHQDNARGLVLPGYKYLPGNGLDKGEPVNA
DAAALEHDKAYDQQLKAGDNPYLKYNHADADEFQERLKEDTSFGGNLGRAVFAQKKRLEPLGLVEEAAK
APGKKRPVDQSPQEPDSSSGVKGSGKQPARKRLNFGQTGDSSEVPDPQPLGEPAAPTSLGSNTMASGG
APMADNNEGADGVGNSSGNWHCDSQWLGDRVITSTRTWALPTYNNHLYKQISSQSGASNDNHYFGYST
PWGYDFDNRFHCHFSRWDQRLINNNWGFPRKLSFKLFNIQVKEVTQNDGTTTIANNLTSTVQVFTDSE
YQLPYVLGSAHQGLPPFPADVFMVPQYGYLTLNNGSQAVGRSSFYCLEYFPSQMLRTGNNFQFSYTFED
VPFHSSYAHSQSLDRLMNPLIDQYLYLNRTQGTTSGTTNQSRLLFSQAGPQMSLQARNWLPGPCYRQQ
RLSKTANDNNNSNFPWTAASKYHLNGRDSL VNP GPAMASHKDDEEKFFPMHGNI LFGKEGTTASNAELDN
VMITDEEEIRTTNPVATEQYGTVANLQSSNTAPTRTVNDQGALPGMVWQDRDVYLQGPWAKIPHTD
GHFHPSPLMGGFGLKHPPPQIMIKNTPVPANPPTTFSPAKFASFITQYSTGQVSVEIEWELQKENS
EIQYTSNYNKSVDFTVDTNGVYSEPRPIGTRYLTRPL

SEQ ID NO: 25 - Polypeptide sequence of wild type human GCase

MEFSSPSREECPKPLSRVSI MAGSLTGLLLLQAVSWASGARPCIPKSFYSSVVCNATYCDSFDPPTFPAL
GTFSTRYESTRSGRRMELSMGPIQANHTGTGLLLTLQPEQKFQKVKGFGGAMTDAAALNILALSPPAQNLLL
KSYFSEEGIGYNIIRVPMASCDFSIRTYTYADTPDDFQLHNFSLPEEDTKLKIPLIHRALQLAQRPVSLASP
TSPTWLKTN GAVNGKGLKQPGDIYHQTWARYFVKFLDAYAEHKLQFWAVTAENEPSAGLLSGYPFQC
LGFTPEHQ RDFIARDLGPTLANSTHHNVRLMLDDQRLLPHWAKVVLTDPEAAKYVHGIAVHWYLDFLA
PAKATLGETHRLFPNTMLFASEACVGSKFWEQSVRLGSWDRGMQYSHSIITNLLYHVVGWTDWNLALNPE
GGPNWVRNFVDSPIVDITKDTFYKQPMFYHLGHFSKFIPEGSQRVGLVASQKNDLDAVALMHPDGS
AVVV
VLNRSSKDVPLTIKDPAVGFLETISPGYSIHTYLWRRQ

FIGURE 10

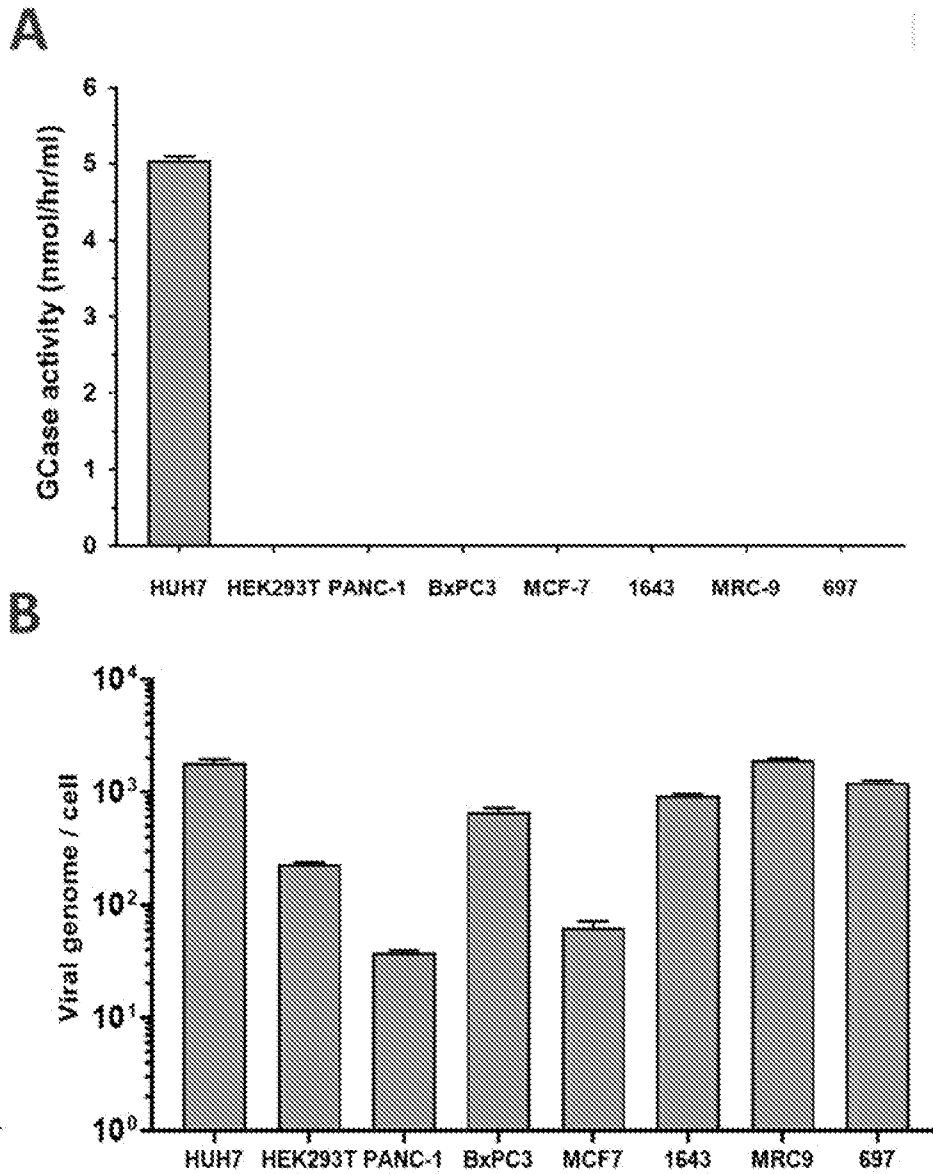
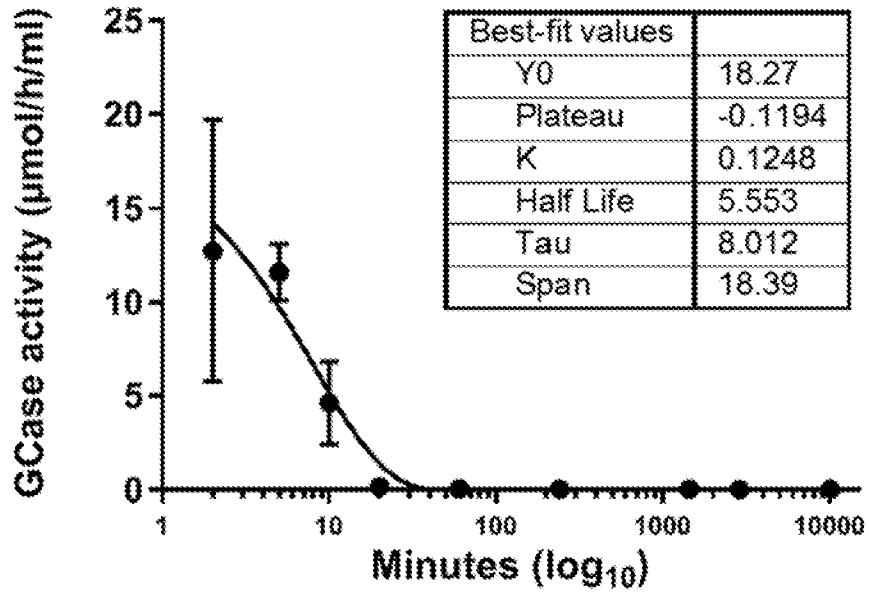

FIGURE 11

A



B

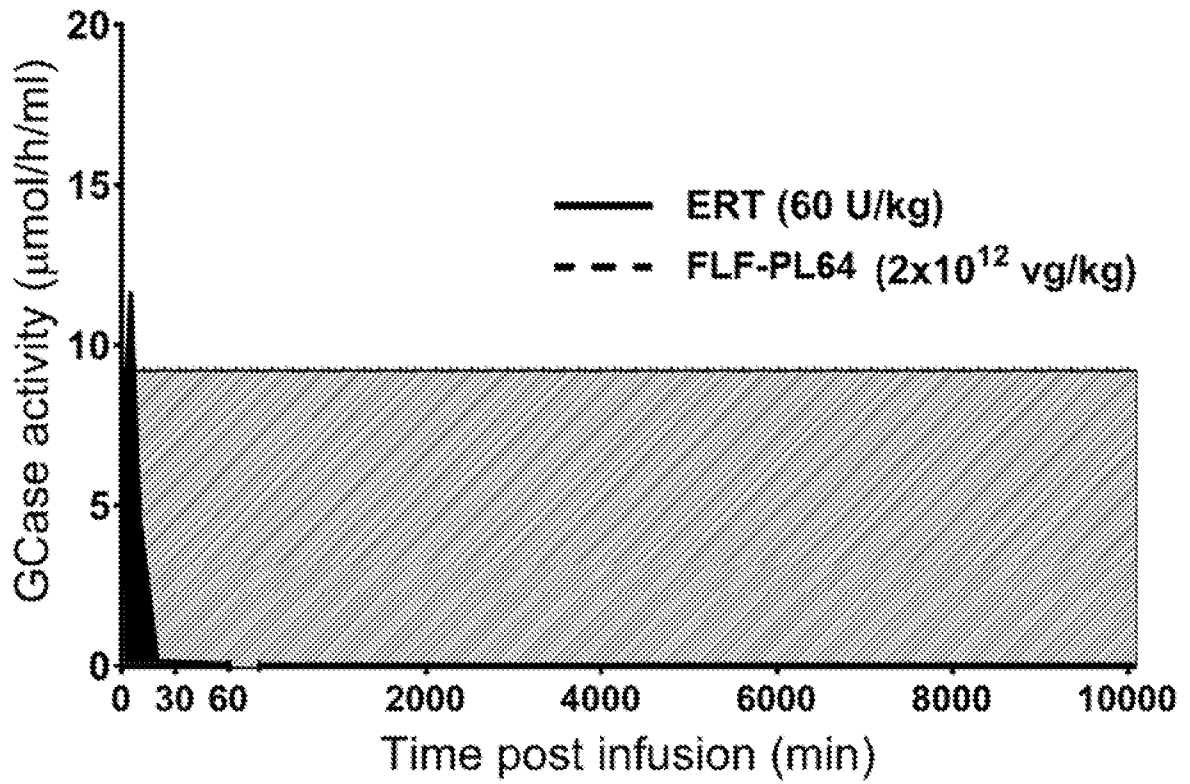

FIGURE 12

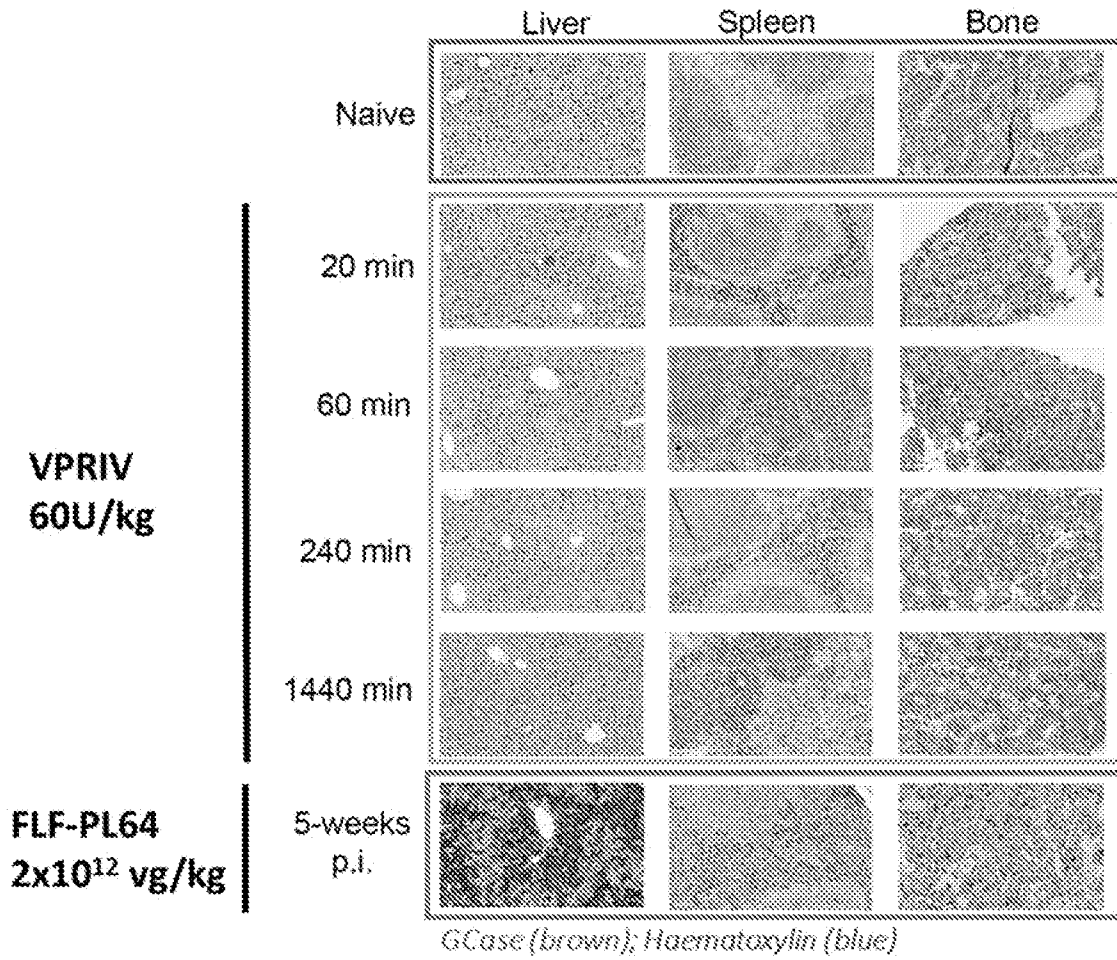

FIGURE 13

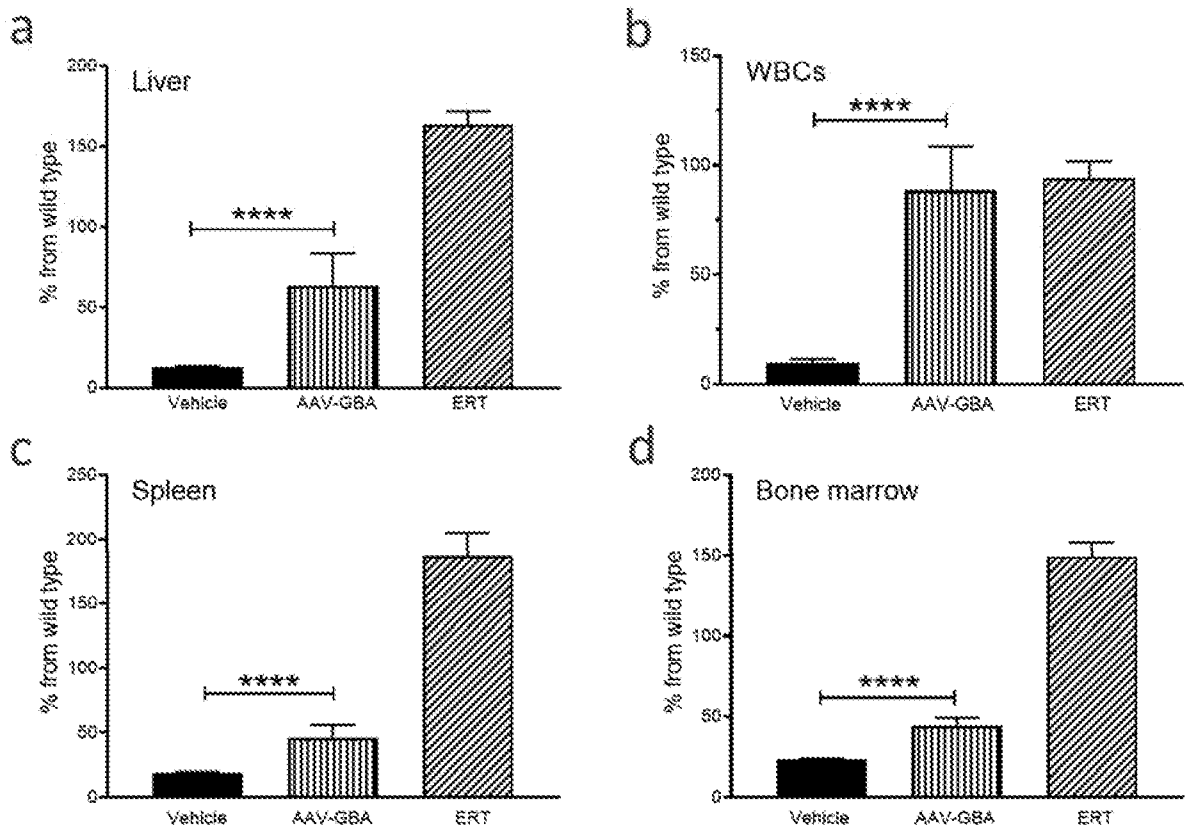

FIGURE 14

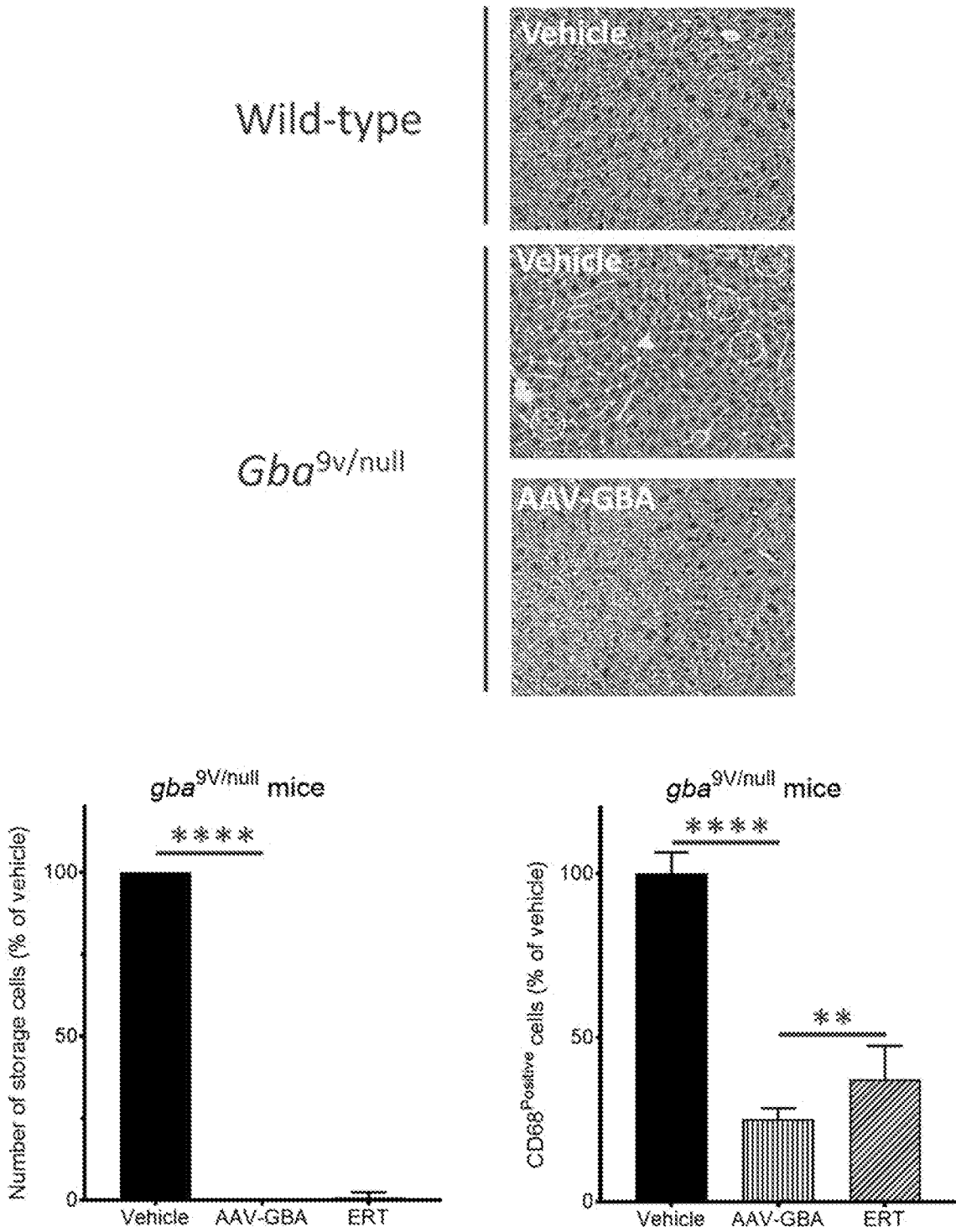
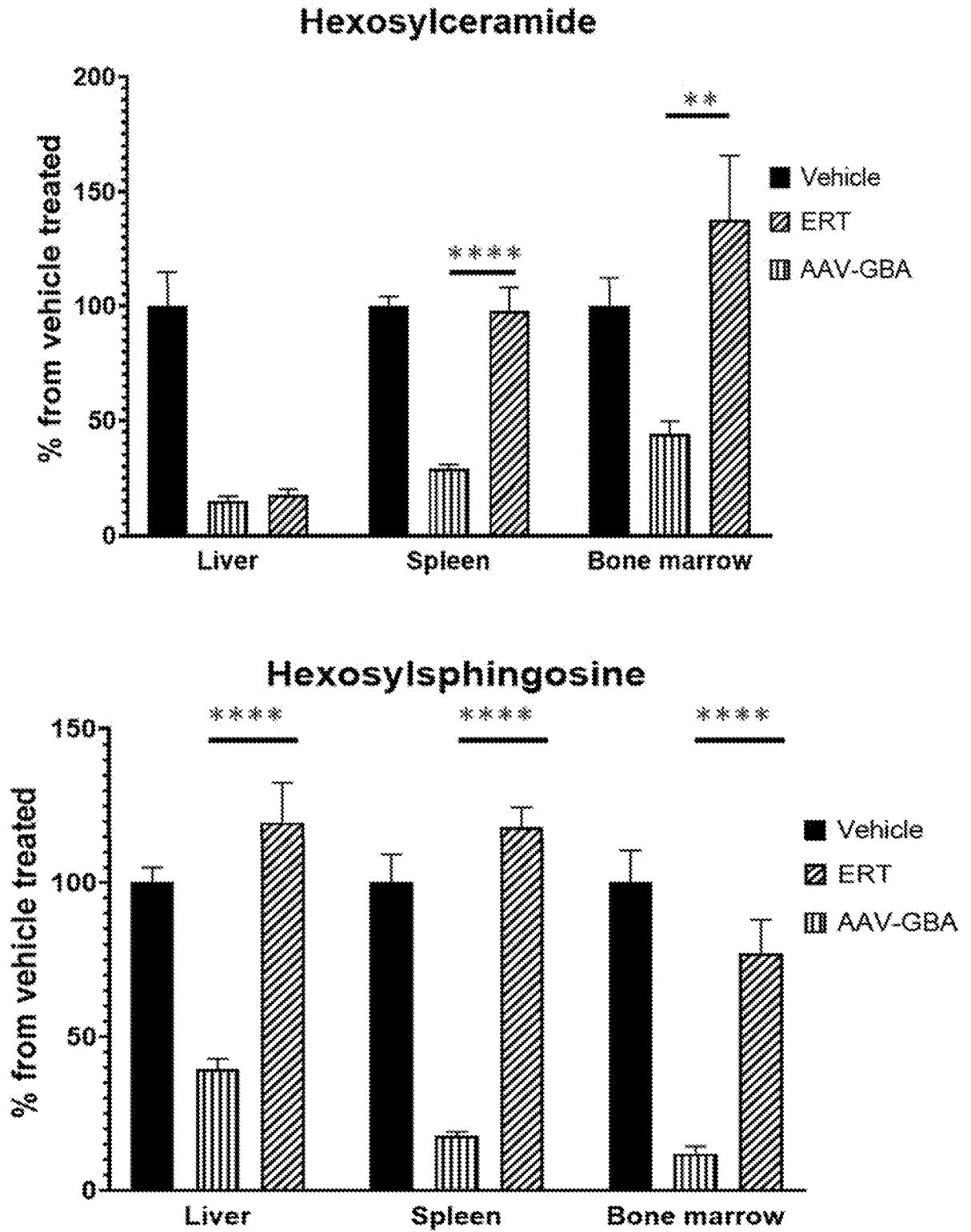

FIGURE 15



INTERNATIONAL SEARCH REPORT

International application No
PCT/GB2020/050251

A. CLASSIFICATION OF SUBJECT MATTER
INV. C12N9/24 A61K38/47 A61P1/16
ADD.
According to International Patent Classification (IPC) or to both national classification and IPC

B. FIELDS SEARCHED
Minimum documentation searched (classification system followed by classification symbols)
C12N A61K A61P
Documentation searched other than minimum documentation to the extent that such documents are included in the fields searched

Electronic data base consulted during the international search (name of data base and, where practicable, search terms used)
EPO-Internal, BIOSIS, Sequence Search, EMBASE, WPI Data

C. DOCUMENTS CONSIDERED TO BE RELEVANT

Category*	Citation of document, with indication, where appropriate, of the relevant passages	Relevant to claim No.
X	"Feasibility of AAV-Mediated Gene Therapy Examined Using a New Murine Model (D409V/null) of Gaucher Disease", MOLECULAR THERAPY : THE JOURNAL OF THE AMERICAN SOCIETY OF GENE THERAPY, CELL PRESS, US, vol. 9, 1 May 2004 (2004-05-01), pages 324-325, XP004635220, ISSN: 1525-0016 the whole document ----- -/--	1-35

Further documents are listed in the continuation of Box C. See patent family annex.

* Special categories of cited documents :

"A" document defining the general state of the art which is not considered to be of particular relevance	"T" later document published after the international filing date or priority date and not in conflict with the application but cited to understand the principle or theory underlying the invention
"E" earlier application or patent but published on or after the international filing date	"X" document of particular relevance; the claimed invention cannot be considered novel or cannot be considered to involve an inventive step when the document is taken alone
"L" document which may throw doubts on priority claim(s) or which is cited to establish the publication date of another citation or other special reason (as specified)	"Y" document of particular relevance; the claimed invention cannot be considered to involve an inventive step when the document is combined with one or more other such documents, such combination being obvious to a person skilled in the art
"O" document referring to an oral disclosure, use, exhibition or other means	"&" document member of the same patent family
"P" document published prior to the international filing date but later than the priority date claimed	

Date of the actual completion of the international search 31 March 2020	Date of mailing of the international search report 30/06/2020
--	--

Name and mailing address of the ISA/ European Patent Office, P.B. 5818 Patentlaan 2 NL - 2280 HV Rijswijk Tel. (+31-70) 340-2040, Fax: (+31-70) 340-3016	Authorized officer Surdej, Patrick
--	---------------------------------------

INTERNATIONAL SEARCH REPORT

International application No.
PCT/GB2020/050251

Box No. II Observations where certain claims were found unsearchable (Continuation of item 2 of first sheet)

This international search report has not been established in respect of certain claims under Article 17(2)(a) for the following reasons:

1. Claims Nos.:
because they relate to subject matter not required to be searched by this Authority, namely:

2. Claims Nos.:
because they relate to parts of the international application that do not comply with the prescribed requirements to such an extent that no meaningful international search can be carried out, specifically:

3. Claims Nos.:
because they are dependent claims and are not drafted in accordance with the second and third sentences of Rule 6.4(a).

Box No. III Observations where unity of invention is lacking (Continuation of item 3 of first sheet)

This International Searching Authority found multiple inventions in this international application, as follows:

see additional sheet

1. As all required additional search fees were timely paid by the applicant, this international search report covers all searchable claims.
2. As all searchable claims could be searched without effort justifying an additional fees, this Authority did not invite payment of additional fees.
3. As only some of the required additional search fees were timely paid by the applicant, this international search report covers only those claims for which fees were paid, specifically claims Nos.:

4. No required additional search fees were timely paid by the applicant. Consequently, this international search report is restricted to the invention first mentioned in the claims; it is covered by claims Nos.:

1-35 (partially)

Remark on Protest

- The additional search fees were accompanied by the applicant's protest and, where applicable, the payment of a protest fee.
- The additional search fees were accompanied by the applicant's protest but the applicable protest fee was not paid within the time limit specified in the invitation.
- No protest accompanied the payment of additional search fees.

FURTHER INFORMATION CONTINUED FROM PCT/ISA/ 210

This International Searching Authority found multiple (groups of) inventions in this international application, as follows:

1. claims: 1-35(partially)

A polynucleotide comprising a GBA nucleotide sequence, wherein the GBA nucleotide sequence encodes a beta-Glucocerebrosidase (GCase) protein or fragment thereof and wherein at least a portion of the GBA nucleotide sequence is not wild type, and comprises a sequence that is at least 95% identical to a nucleotide sequence of any one of SEQ ID NO: 1 or 5

2. claims: 1-35(partially)

A polynucleotide comprising a GBA nucleotide sequence, wherein the GBA nucleotide sequence encodes a beta-Glucocerebrosidase (GCase) protein or fragment thereof and wherein at least a portion of the GBA nucleotide sequence is not wild type, and comprises a sequence that is at least 95% identical to a nucleotide sequence of any one of SEQ ID NO: 2 or 6

3. claims: 1-35(partially)

A polynucleotide comprising a GBA nucleotide sequence, wherein the GBA nucleotide sequence encodes a beta-Glucocerebrosidase (GCase) protein or fragment thereof and wherein at least a portion of the GBA nucleotide sequence is not wild type, and comprises a sequence that is at least 95% identical to a nucleotide sequence of any one of SEQ ID NO: 3 or 7

4. claims: 1-35(partially)

A polynucleotide comprising a GBA nucleotide sequence, wherein the GBA nucleotide sequence encodes a beta-Glucocerebrosidase (GCase) protein or fragment thereof and wherein at least a portion of the GBA nucleotide sequence is not wild type, and comprises a sequence that is at least 95% identical to a nucleotide sequence of any one of SEQ ID NO: 4 or 8

INTERNATIONAL SEARCH REPORT

International application No

PCT/GB2020/050251

C(Continuation). DOCUMENTS CONSIDERED TO BE RELEVANT		
Category*	Citation of document, with indication, where appropriate, of the relevant passages	Relevant to claim No.
X	<p>US 7 452 716 B2 (GENZYME CORP [US]) 18 November 2008 (2008-11-18) column 1, line 5 - line 10 column 2, line 36 - line 42 column 3, line 11 - line 19 column 3, line 54 - column 4, line 26 column 7, line 33 - line 53 figure 5 claims 1-3</p>	1-35
X	<p>-----</p> <p>WO 2019/009979 A1 (THE MEDICAL COLLEGE OF WISCONSIN INC [US] ET AL.) 10 January 2019 (2019-01-10) paragraphs [0003], [0008], [0011], [0060] - [0061], [0099] - [0100], [0117] - [0120] examples 1, 6</p>	1-35
X	<p>-----</p> <p>JOHN MARSHALL ET AL: "Demonstration of Feasibility of In Vivo Gene Therapy for Gaucher Disease Using a Chemically Induced Mouse Model", MOLECULAR THERAPY : THE JOURNAL OF THE AMERICAN SOCIETY OF GENE THERAPY, vol. 6, no. 2, 1 August 2002 (2002-08-01), pages 179-189, XP055679288, US ISSN: 1525-0016, DOI: 10.1006/mthe.2002.0650 abstract page 183, right-hand column, paragraph 2 - page 184, right-hand column, paragraph 1 page 187, right-hand column, paragraph 5 - paragraph 6 figures 4-6</p>	1-35
X	<p>-----</p> <p>US 2006/188482 A1 (KAY MARK A [US] ET AL) 24 August 2006 (2006-08-24) paragraphs [0023], [0038] - [0037], [0063]</p>	1-35
X	<p>-----</p> <p>US 2006/104954 A1 (PODSAKOFF GREGORY [US] ET AL) 18 May 2006 (2006-05-18) paragraphs [0013], [0027] - [0029], [0058] - [0060], [0201] - [0207], [0216] - [0219] figures 10-12 example 3</p> <p>-----</p> <p style="text-align: center;">-/--</p>	1-35

INTERNATIONAL SEARCH REPORT

International application No
PCT/GB2020/050251

C(Continuation). DOCUMENTS CONSIDERED TO BE RELEVANT

Category*	Citation of document, with indication, where appropriate, of the relevant passages	Relevant to claim No.
T	<p>MIRANDA CARLOS J ET AL: "One-off liver directed AAV gene therapy achieves long term uptake of acid beta-glucocerebrosidase by macrophages of affected tissues in Gaucher disease", MOLECULAR GENETICS AND METABOLISM, ACADEMIC PRESS, AMSTERDAM, NL, vol. 129, no. 2, 31 January 2020 (2020-01-31), XP086021543, ISSN: 1096-7192, DOI: 10.1016/J.YMGME.2019.11.283 the whole document -----</p>	1-35

INTERNATIONAL SEARCH REPORT

Information on patent family members

International application No

PCT/GB2020/050251

Patent document cited in search report	Publication date	Patent family member(s)	Publication date
US 7452716	B2	18-11-2008	AT 310096 T 15-12-2005
		AU 9098401 A	02-04-2002
		CA 2423082 A1	28-03-2002
		DE 60115070 T2	27-07-2006
		EP 1319082 A2	18-06-2003
		ES 2252293 T3	16-05-2006
		JP 6209566 B2	04-10-2017
		JP 2004516016 A	03-06-2004
		JP 2013048624 A	14-03-2013
		JP 2016019524 A	04-02-2016
		JP 2018007673 A	18-01-2018
		US 2002090719 A1	11-07-2002
		US 2007003521 A1	04-01-2007
		WO 0224932 A2	28-03-2002

WO 2019009979	A1	10-01-2019	EP 3648776 A1 13-05-2020
			US 2020181582 A1 11-06-2020
			WO 2019009979 A1 10-01-2019

US 2006188482	A1	24-08-2006	US 2004009151 A1 15-01-2004
			US 2006188482 A1 24-08-2006

US 2006104954	A1	18-05-2006	AU 1775901 A 30-05-2001
			US 6582692 B1 24-06-2003
			US 2003219414 A1 27-11-2003
			US 2006104954 A1 18-05-2006
			WO 0136603 A2 25-05-2001
