

Aug. 9, 1932.

J. M. MAHER

1,871,069

BLADE HOLDER

Filed Dec. 20, 1930

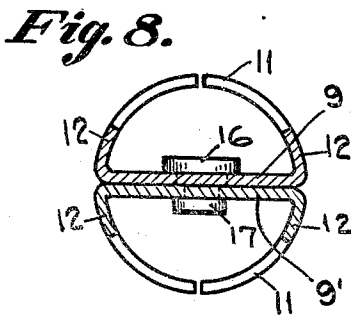
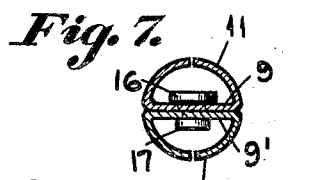
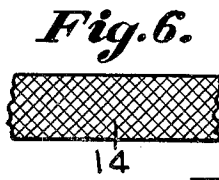
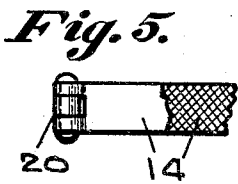
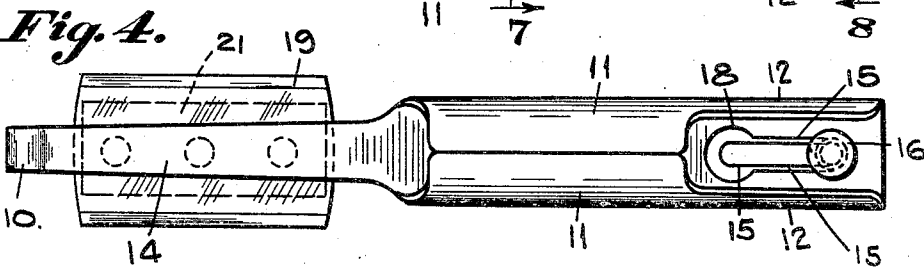
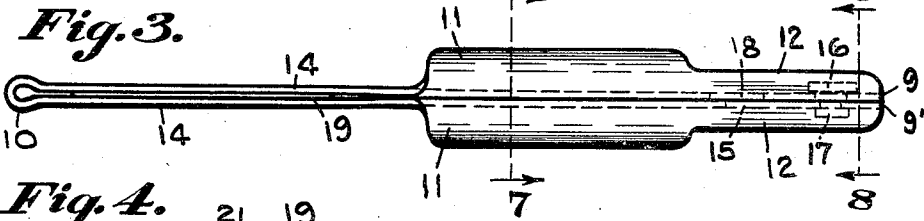
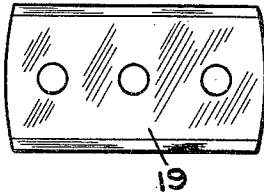
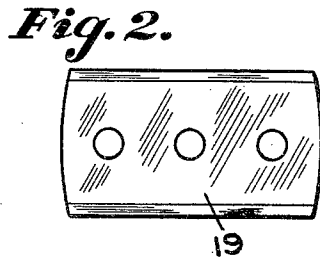
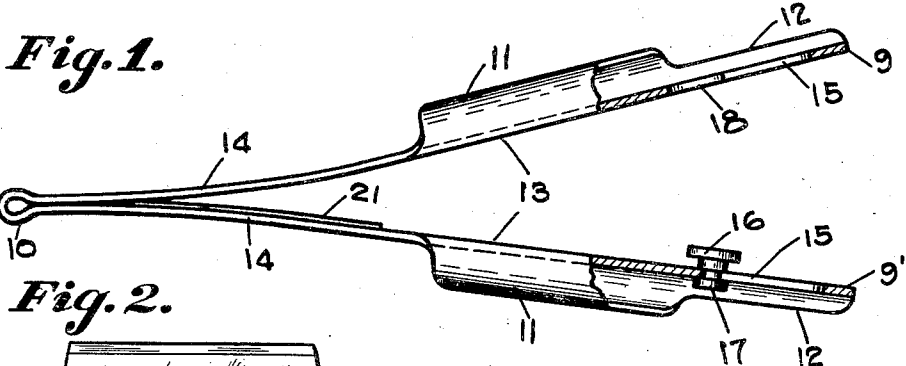

Inventor

J. M. Maher

By

Hiram A. Sturges Attorney

# UNITED STATES PATENT OFFICE

JAMES M. MAHER, OF FREMONT, NEBRASKA

## BLADE HOLDER

Application filed December 20, 1930. Serial No. 503,800.

This invention relates to a blade-holder particularly adapted for holding the blades of safety razors for honing or stropping.

One of the objects of the invention is to provide a device which will be convenient in use when removing the blade from the holder or when mounting the blade therein.

Another object is to provide such a construction that the blade will be securely held and to provide a suitable handle so that stropping may be conveniently and accurately accomplished.

The invention includes the use of elastic metallic strips of such form that a pair of handle-members may be produced each being integral with a strip and which conduces to economy in manufacture.

Also the invention includes elastic metallic strips of such normal curvature that the blade will be held more firmly than ordinary, and for this purpose one of the curved strips is provided with a stabilizing plate for stropping the blade.

With the foregoing objects in view and others to be mentioned the invention presents a new and useful construction, combination and arrangement of parts as described herein and claimed, and as illustrated in the accompanying drawing, it being understood that changes may be made in form, size, proportion and minor details, said changes being within the scope of the invention as claimed.

In the drawing, Fig. 1 is a side view of a blade-holder embodying my invention, a stabilizing-plate being shown and the pair of handle-members being broken away to show locking means. Fig. 2 is a plan view of a safety razor blade.

Fig. 3 is a side view showing the device in closed or locked position, the stabilizing-plate being omitted, and Fig. 4 is a plan view of the device.

Fig. 5 is a detail showing a hingeable connection for the pair of elastic strips employed, this being a modified form of the invention.

Fig. 6 is a broken away detail showing a milled or rugose surface for the inner side of the pair of elastic strips employed. Fig. 7 is a transverse section on line 7—7 of Fig.

3. Fig. 8 is an enlarged transverse section on line 8—8 of Fig. 3. Fig. 9 is a broken away plan view showing a stabilizing-plate and portion of the device.

Referring now to the several figures of the drawing, except Fig. 5, for a more particular description, numerals 9 and 9', best shown in Fig. 1, indicate a pair of metallic, elastic strips, preferably constructed of a single strip of spring steel incised and bent midway between its ends to form a small reinforcing spring 10, a pair of semi-circular handle-members 11, each having a reduced terminal part 12; that part of each flat strip 9 and 9' which carries a handle-member 11 and its reduced part 12 being rectilinear as indicated at 13, and that part of each strip 9 and 9' between its handle-member and spring 10 having a normal uniform, longitudinal, inward curvature as indicated at 14.

As thus described the strips 9 and 9' are alike in all respects, except that one of the strips is provided with a stabilizing plate 21. This stabilizing-plate, preferably, has a greater width than the width of the curved parts 14, as best shown in Figs. 4 and 9 of the drawing, and is secured to one of the parts 14 by electrical welding. Each strip 9 and 9' is provided with a slot 15, the slot in the strip 9' having a lesser width than the slot in the strip 9, as clearly shown in Fig. 4 of the drawing. I provide a clamping element or slide-piece having a comparatively large head 16 and a lesser head 17, said slide-piece being carried by the strip 9' since its head 16 has a greater diameter than the width of the slot in said strip 9'. Numeral 18 indicates a recess which opens on the slot of the strip 9, said recess having a greater diameter than the diameter of the head 16 of the slide-piece to permit said recess to operate as a passageway for the head 16 to move therethrough.

In operation, the blade 19 may be inserted between the curved portions 14 of the strips 9 and 9', and placed on the stabilizing-plate 21. The operator, with one of his hands, may then grasp the handle-members 11 and may move them toward each other, and since

the portions 14 have inward curvatures relative to each other the blade will be firmly pressed therebetween before the rectilinear parts 13 move into engagement.

5 When the parts 13 of the strips 9 and 9' move into engagement the head 16 of the slide-piece will have passed through the recess 18 and the operator then moves the slide-piece in the slots 15 toward the adjacent  
10 free ends of said strips for securing said strips in locked relation.

After the device has been used, the blade may be readily removed. For this purpose the slide-piece is moved in the slots 15 in  
25 a reverse direction to permit the head 16 to move through the recess 18, said strips automatically moving to their normal V-shaped position shown in Fig. 1.

It will be appreciated that if the strips  
30 9 and 9' were both rectilinear throughout their entire length the blade 19, which may be entirely attenuated, would be held less securely, but since the parts 14 have relative inward curvatures and a stabilizing-plate 21 is provided, the blade, on account  
35 of this construction, will be rigidly held, and during the operation of stropping will not be moved from its gripped position.

Since the stabilizing-plate has a lesser  
40 width than the blade, it does not interfere with the operation of stropping. It provides a seat for the blade, and since the blades of safety razors are extremely thin they are occasionally broken during their sliding  
45 movements on the strop, and this may be prevented by use of the plate 21. However, in some instances the blades may have an adequate thickness to avoid breakage, and I do not wish to be limited to the use of the  
50 stabilizing-plate.

It will be appreciated, by referring to Figs. 1, 3, 4 and 8 of the drawing, that the slide-piece will be protected from accidental displacement since the slots 15 are disposed  
55 in the reduced parts 12 of the handle-members 11. Also it will be seen that, since the slots and slide-piece are disposed in the reduced parts 12 the slide-piece may be conveniently moved by an operator.

To facilitate maintaining a blade in a stationary position during the operation of stropping the inner sides of the parts 14 of the strips may be of rugose or milled construction as shown in Figs. 5 and 6 of the  
60 drawing.

In the modified form of the invention shown in Fig. 5, two separate strips are used and are connected by a terminal hinge joint 20, all other parts being the same as described,  
65 and since operation will be the same I may employ this hinge joint if desired as it provides a convenient and economical construction. It will be noted that the pintle for the hinge 20 is disposed parallel with the flat sides of the strips 14.

It will be understood that, by use of the device, razor blades differing in form and size may be held in stationary position between the curved portions 14 of the strips.

It will be noted that, in Fig. 3 of the drawing, the strips 9 and 9' are disposed practically parallel, their normally curved parts 14 being pressed into that position by use of the handle-members 11. The normal position of the device is approximately of V-shape and since the strips are elastic, the curved parts 14 operate effectively in firmly holding the blade as soon as the parts 13 of the strips are pressed to parallel positions.

It is obvious that the herein described device would operate for holding the blade if only one of the parts 14 was of curved form, and I do not wish to limit myself in this respect.

I claim as my invention,—

A razor blade holder, comprising a single length strip of spring metal overturned intermediately to provide a pair of arms, said arms being curved outwardly from each other to inherently hold the arms in divergent relation, each of said arms having an outwardly curved handle portion near its outer end and the handle portions adapted to register when the arms are pressed together, the free ends of said arms having inner opposed flat faces adapted for abutting engagement when the arms are brought together, said outer end flat portions having registering slots therein, a locking member carried by one of said arms operable in said slots for interlocking the arms together when closed, and a supporting plate secured across the inner side of one of said arms adapted to receive a razor blade thereon, said arms adapted to clamp the razor blade between the arms with the cutting edges of the blade extending beyond the opposite longitudinal edges of the arm.

In testimony whereof, I affix my signature.

JAMES M. MAHER.