

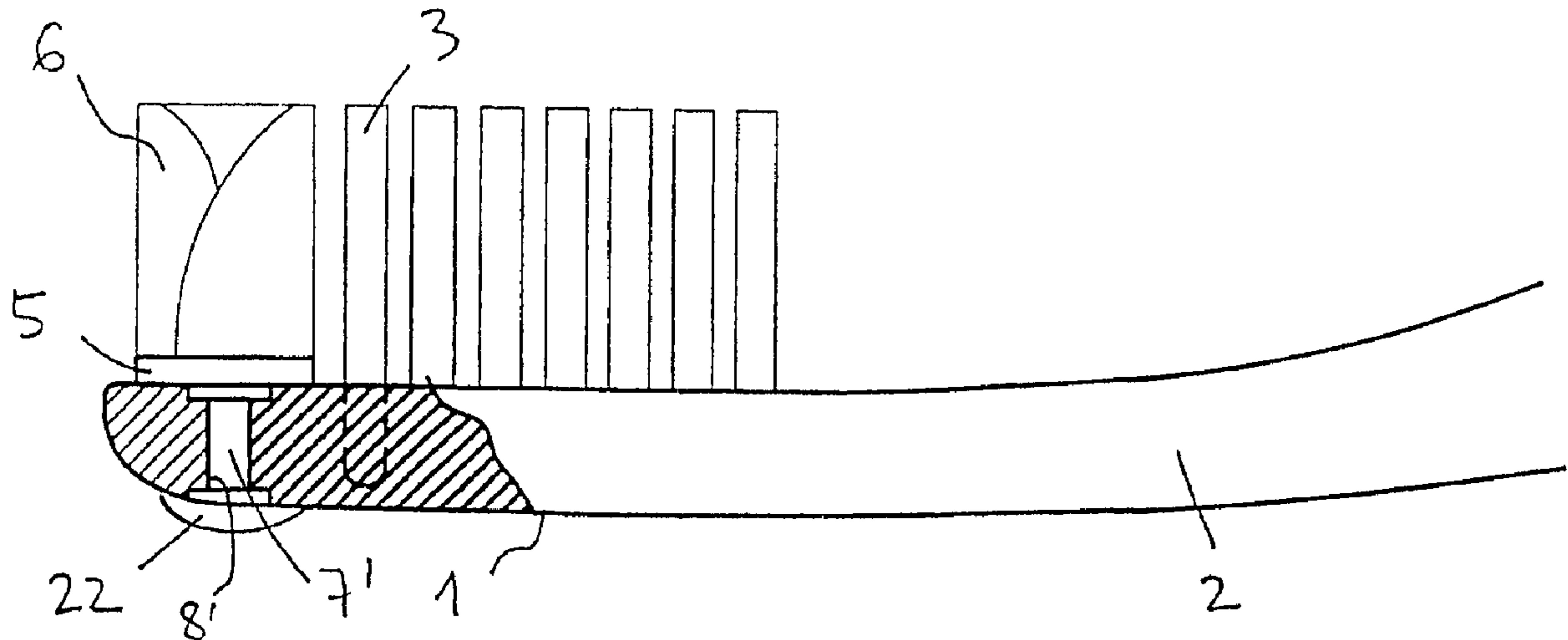

(22) Date de dépôt/Filing Date: 2002/12/20
 (41) Mise à la disp. pub./Open to Public Insp.: 2003/07/10
 (45) Date de délivrance/Issue Date: 2013/08/06
 (62) Demande originale/Original Application: 2 468 340
 (30) Priorité/Priority: 2001/12/28 (DE101 64 336.5)

(51) Cl.Int./Int.Cl. *A46B 9/06* (2006.01),
A46B 15/00 (2006.01), *A46B 9/04* (2006.01),
B29C 65/02 (2006.01), *B29C 65/48* (2006.01)
 (72) Inventeurs/Inventors:
 FISCHER, FRANZ, CH;
 STRAEHLER, RETO, CH
 (73) Propriétaire/Owner:
 TRISA HOLDING AG, CH
 (74) Agent: GOWLING LAFLEUR HENDERSON LLP

(54) Titre : PORTE-POILS FIXE A UNE STRUCTURE SOUPLE
 (54) Title: BRISTLE CARRIER HAVING A FLEXIBLE STRUCTURE ATTACHED THERETO



(57) Abrégé/Abstract:

The invention relates to a toothbrush having a handle (2) and a head part (1), on which bristle filaments (3) and at least one flexible cleaning element (6) are arranged. According to the invention, the at least one flexible cleaning element (6) is arranged on a carrier element (5) which consists of a hard material and is connected to the head part (1). The invention also relates to a process for producing such a toothbrush.



Abstract

The invention relates to a toothbrush having a handle (2) and a head part (1), on which bristle filaments (3) and at least one flexible cleaning element (6) are arranged. According to the invention, the at least one flexible cleaning element (6) is arranged on a carrier element (5) which consists of a hard material and is connected to the head part (1). The invention also relates to a process for producing such a toothbrush.

**Bristle Carrier Having A Flexible Structure
Attached Thereto**

The invention relates to a toothbrush and for a process which is intended for producing the same.

5 Toothbrushes with a conventional bristle arrangement comprising clusters of bristle filaments, e.g. made of a polyamide (PA) or polyester (PBT), and an additional flexible structure are known, for example, from WO 00/64307 and WO 01/21036. The conventional bristles
10 here serve for customary teeth-cleaning purposes, while the flexible structure can perform different functions, e.g. massaging the gums, damping the cleaning movement, removing plaque, polishing the tooth surface, suspending the bristles in an elastic manner and/or sealing non-
15 welded locations. WO 00/64307 discloses a toothbrush with rod-like flexible cleaning elements which are of approximately the same length as the conventional clusters of bristles and are arranged on the periphery of the head part of the toothbrush. In the case of WO
20 01/21036, elastic cleaning elements are of sheet-like, e.g. undulating, configuration and are arranged within the conventional bristle arrangement. In the case of WO 00/64307, a plurality of the flexible cleaning elements are connected to one another via a material bridge made
25 of the same material.

Following the operation of covering the head part of the toothbrush with conventional bristles, the cleaning elements are produced by virtue of the head part being encapsulated by injection molding. The disadvantage
30 here is that the bristle filaments have to be prepared for use, e.g. by virtue of the clusters of bristles

being rounded or a predetermined profiling being produced, before the flexible structure is produced. Renewed insertion into the injection mold is then necessary in order to produce the flexible structure.

5 It is possible here for the clusters of bristles to be damaged or contaminated. The elastic-structure shapes which it is possible to produce are limited, inter alia, for demolding reasons.

The object of the invention is to provide a toothbrush,
10 with conventional bristles and a flexible structure, which is straightforward to produce. The intention is also to specify a corresponding production process.

The object may be achieved by a toothbrush having a handle and a head part with bristle filaments and a
15 flexible structure, having at least one flexible cleaning element. The flexible structure may be arranged on a carrier element which consists of a hard material, the carrier element being fastened on the head part by means of a snap-fitting or latching connection,
20 the carrier element having an extension and the head part having a cutout for receiving the extension and/or the carrier element.

The object may also be achieved by a process which is intended for producing such a toothbrush. The process
25 for producing such a toothbrush may consist of producing a carrier element consisting of a hard material and with an extension, a flexible structure having at least one flexible cleaning element being fastened on the carrier element and a handle and a head part with a cutout for
30 receiving the extension. The carrier element may be fastened on the head part by means of a snap-fitting or

latching connection, in that the extension of the carrier element and/or the carrier element itself is inserted into the cutout.

Advantageous developments can be gathered from the dependent claims, the description and the drawings.

According to the invention, in the case of a toothbrush of the type mentioned in the introduction, at least one flexible structure, e.g. a cleaning element, is arranged on a carrier element which consists of a hard material. This carrier element is connected to the head part. Such a toothbrush has production-related advantages since the additional part, i.e. the carrier element provided with the flexible structure, can be produced separately and straightforwardly connected to the head part.

The connection between the carrier element and the head part may be produced mechanically by clamping or snap-fitting or riveting, chemically by adhesive bonding, by ultrasonic welding, or thermally by welding or other methods of supplying heat. It is preferred, in terms of production, for the carrier element to consist of the same material as the head part since, in this case, only one hard component need be provided for producing the brush and there is no need to ensure material compatibility. This is advantageous, in particular, for ultrasonic welding.

- 3 -

The arrangement of the flexible structure on a carrier element consisting of a hard material has the following advantages: the additional part may be produced, and prepared for use, separately from the rest of the toothbrush body, comprising the handle and head part. In a straightforward further step, the carrier element is connected to the head part, it being possible to use any of the abovementioned connecting methods and the hard carrier element preferably being formed in adaptation to said head part. The carrier element may be formed, for example, such that, during the later connecting step, it engages around the head part in a clamping manner. On account of the hard carrier element, the additional part is easy to handle and can be gripped considerably more easily than an additional part produced entirely from a flexible material.

The additional part is small in comparison with the rest of the toothbrush. The necessary molds are thus also small and cost-effective. The basic toothbrush body and the bristle covering may be produced using a standard mold even if they are later provided with different additional parts. In order to produce toothbrushes with different additional parts, all that is necessary is to exchange the additional part and/or the corresponding mold therefor, which can be done in a straightforward and cost-effective manner.

A further advantage of producing the additional part and basic body separately is that it is possible to realize any desired shapes of flexible cleaning elements, e.g. even those which cross over the conventional bristles, come into contact therewith or displace the same when the additional part is inserted. The separate production does not pose any problems for the demolding of the flexible structure. It is possible to produce geometries by injection molding which would be extremely difficult to demold if the cleaning

- 4 -

element were fitted directly on the bristle-covered head part.

Up until now, the flexible structure, for production-related reasons, has been produced from the same material as any flexible components on the handle part. The invention provides a greater degree of freedom for the material of the structure, with the result that it is possible to use, for example, a different degree of hardness.

A non-releasable connection between the additional part and the head part prevents the additional part from detaching during use and eliminates the risk of swallowing.

The conventional bristles are fastened, for example, directly on the head part, on a bristle plate acting as a further carrier element, or also on the carrier element for the flexible cleaning elements, all variants having advantages. During the operation of fastening the bristles on the head part or on the bristle plate, the flexible structure and the conventional bristles may be prepared independently of one another for later use before the head part and additional part are assembled, with the result that they do not damage or contaminate one another.

Fitting both conventional bristles and the flexible structure on the carrier element has the advantage that any desired spatial arrangement of the two components is possible. A carrier element which is prepared in this way may be connected to different basic toothbrush bodies for finishing purposes, with the result that it is possible to realize a large number of different toothbrushes with only a small number of basic bodies.

The conventional bristles, in both cases, may be prepared for use before or after the flexible structure

is fitted. If the two components are provided on the carrier element, it is preferable first of all for the flexible structure, including any cleaning elements, to be integrally formed and then for the carrier element to be covered with bristles, which may be guided, for example, through cutouts in the soft or hard component.

Producing the additional part, i.e. the carrier element with one or more flexible cleaning elements, preferably takes place by two-component or multi-component injection molding. In this case, a non-releasable connection is preferably produced between the components.

The flexible structure is preferably also arranged, e.g. molded, laterally on the carrier element, in which case, in the assembled state, it terminates laterally with the outer contour of the head part or projects beyond the same. It serves, for example, for sealing non-welded locations, for massaging the gums, e.g. by way of molded-on elastic elements which project slightly, or as impact protection during cleaning.

The flexible cleaning element preferably consists of an, in particular, thermoplastic elastomer, e.g. of natural or synthetic rubber. The material used for the basic toothbrush body is preferably used for the carrier element, in particular polypropylene, styrene-acrylonitrile, polyester, acrylonitrile-butadiene-styrene (ABS) or Isoplast®. The Shore A hardness of the soft component is preferably less than 90 and particularly preferably below 50.

The carrier element is particularly preferably covered with bristles by AFT (Anchor Free Tufting) technology. In this case, first of all, the hard-material carrier plate is produced with the flexible structure, in particular by two-component injection molding. Then, the bristle filaments are guided through cutouts in the

- 6 -

carrier plate and/or in the flexible structure and, for fastening on the carrier plate and/or the flexible structure, are welded or adhesively bonded by way of their rear ends, which in the application case are
5 directed toward the brush head. This has the advantage that it is possible to realize largely any desired bristle arrangements, in particular even sheet-like bristle structures. The carrier element is connected to the head part, in particular, by means of ultrasonic
10 welding, e.g. as is described in DE 200 06 311 U.

Since elastomeric material, in particular a thermoplastic elastomer, on account of the pronounced damping of the ultrasonic vibrations, can only be
15 welded ultrasonically to a limited extent, the welding surface between the carrier element and head part is preferably kept at least partially free of the flexible component. For this purpose, the injection point of the soft component is preferably selected to be on the
20 bristle-carrying side of the carrier element, in order that no material bridges from the soft component reduce the size of the welding surface. However, for the case where flexible elements are intended to be arranged in the region of the welding surface, they are preferably
25 positioned to the side of the longitudinal axis of the toothbrush. This likewise produces non-welded locations laterally on the carrier element, while it is possible to weld the longitudinally front and rear regions between the carrier element and head part. This ensures
30 that the carrier element is held well since the front and rear regions, in particular, and, to a lesser extent, the side regions, are subjected to loading by the cleaning movement and the corresponding leverages. Merely punctiform welding with non-welded locations may
35 also be used specifically, in order that the brush head and carrier element can be moved in relation to one another and a certain level of flexibility of the brush head as a whole is thus achieved.

It is also possible for the flexible structure, in the manner of a sealing lip, to serve for the additional sealing of non-welded locations. As a result, the space between the carrier element and the head part is advantageously sealed against the ingress of water. It is thus not possible for any germs to accumulate in this region, and the brush is more hygienic. In order to achieve a reasonable sealing function, the Shore A hardness of the software component is preferably less than 50.

Examples for the invention are described hereinbelow and illustrated in the drawings, in which, purely schematically:

Figures 1a-d show views of a toothbrush according to the invention in various assembly stages, the additional part being fastened on the head part by riveting;

Figures 2a-e show views of a further toothbrush of which the additional part is fastened by riveting;

Figures 3a-e show views of a toothbrush of which the additional part is fastened by welding;

Figures 4a-e show views of a toothbrush of which the additional part is fastened by means of a snap-fitting connection;

Figures 5a-e show views of a further toothbrush of which the additional part is fastened by a snap-fitting connection;

Figures 6a-f show views of a toothbrush in the case of which the additional part is fastened in a clamping manner;

- 8 -

Figures 7a-e show the production of a toothbrush by AFT;

5 Figures 8a-e show views of a further toothbrush of which the additional part is fastened by a snap-fitting connection;

10 Figures 9a-f show views of a further toothbrush, of which the additional part is fastened on the head part with play;

Figures 10a-j show the production of a further toothbrush by AFT; and

15 Figures 11a-c show views of a toothbrush with a lateral surround made of flexible material.

20 All of the toothbrushes illustrated have a basic body with a head part 1 and a handle part 2, which is only partially illustrated. An additional part 4 with a plurality of flexible cleaning elements 6 of different shapes, which are connected to a carrier element of likewise different shapes, is connected to the head
25 part 1 when the toothbrush is in the finished state. The head part 1, furthermore, is provided directly (figures 1-5) or indirectly (figure 6) with clusters 3 of conventional bristle filaments. The materials and arrangements of the clusters of bristles 3 may vary. It
30 is only the special features of the individual exemplary embodiments which are discussed hereinbelow, and elements which correspond to one another are provided with the same designations.

35 Figures 1a and c show a toothbrush of which the head part 1 has already been provided with clusters of bristles 3. The additional part 4 illustrated in figure 1b has a sectionally U-shaped carrier element 5 made of a hard material, in particular the same plastic which

- 9 -

has been used for producing the head part 1 and/or the entire basic body. Flexible cleaning elements 6, in this case in the form of straight rods, are firmly connected to the carrier element 5. The cleaning elements 6 are inclined slightly out of the vertical, toward one another, and enclose an angle of from 5 to 30° with the vertical. In this way, the elastic cleaning elements 6 come into contact with the conventional clusters of bristles 3 (figure 1d) and may even cross over (not illustrated) the latter. Using conventional production processes, such a position can only be realized with high-outlay displacement methods.

The carrier element 5 is adapted in shape to a cutout 9, visible in figure 1c, in that region of the head part 1 which is directed away from the clusters of bristles 3. Also located in this region are pins 7, which can be plugged through a hole 8 in the carrier element 5. The pins 7 are cold-formed or hot-formed and thus permanently fixed in the hole 8. Figure 1d shows a plan view of the finished toothbrush.

For reasons of esthetics or hygiene, the bottom region of the hole 8 or of the head part 1 as a whole may be covered by a protective layer 22 made of soft plastic (cf. figure 2d). The boundary regions between the carrier element 5 and the head part 1 are likewise preferably covered by soft plastic. An example of the material used for this purpose is the soft material which is also used for the handle region of the toothbrush. The protective layer is preferably molded on during the production of the handle part by multi-component injection molding. It is also possible, however, for the plastic layer to be integrally formed directly on the carrier element.

A further example of a toothbrush of which the additional part 4 is connected to the head part 1 by riveting is illustrated in figures 2a-e. The additional

- 10 -

part, in this case, comprises a plate-like carrier element 5 to which sheet-like flexible cleaning elements 6 are connected in the form of a rosette. The carrier element 5 has a pin 7' by means of which the additional part 4 can be plugged through a correspondingly prepared hole 8' in the front end of the head part and can be fixed by virtue of the pin 7' being deformed. The flexible cleaning elements 6 are located in the region of the tip of the head part 1.

10 The bristle arrangement with individual clusters of bristles 3 follows in the direction of the handle part 2. A protective layer 22 covers the region of the hole 8'.

15 Figures 3a-e show a further example of a toothbrush, which ends up similar to a toothbrush according to figure 2. The additional part 4 with a plate-like carrier element 5 and rosette-like flexible cleaning elements 6, in this case, is connected to the head part

20 1 by welding. For this purpose, the front region of the head part has a plate-like cutout into which the carrier element 5 is permanently introduced, by way of a correspondingly structured underside 5a, by means of ultrasonic welding. Figure 3d shows a side view of the

25 finished-toothbrush, and figure 3e shows the plan view of the combined bristle arrangement comprising conventional clusters of bristles 3 and flexible cleaning elements 6.

30 The additional part 4 of the toothbrush illustrated in figures 4a-e is fastened in the center of the head part 1 by means of snap-fitting. The additional part 4 comprises a rectangular carrier element 5 with wing-like flexible cleaning elements 6 arranged at its

35 corners. Two rod-like cleaning elements 6 are also located on the carrier element 5 (figures 4b and c). As is illustrated in figure 4a, the head part 1 has a central hole 8'', through which a resiliently configured extension 11 on the carrier element 5 is

- 11 -

plugged. The additional part 4 and head part 1 are connected to one another by a snap-fitting connection which, on account of the enlarged cross section at the bottom end 11a of the extension 11, cannot readily be released. The bristle arrangement of the conventional clusters of bristles 3 is configured such that the wing-like cleaning elements 6 are positioned between the conventional clusters of bristles 3, as is illustrated in figures 4a and 4e. The additional part 4 is produced separately and then inserted into the head part 1 with the prepared bristle arrangement. It is thus also possible to realize structures of the flexible cleaning elements 6 which engage through the convention bristle arrangement, such as the diagonally arranged wing-like elements from figures 4b-e or the fanned-out pin-like cleaning elements, oriented in different directions in space, from figure 8. For reasons of hygiene or esthetics, the underside of the head part 1 is covered by a layer 22 made of flexible material.

Figures 5a-e show a further example of a snap-fitting connection between the additional part 4 and the head part 1 of a toothbrush according to the invention. Within the bristle arrangement made of conventional clusters of bristles 3, the head part 1 has a prepared region 13 for accommodating the additional part 4. This region 13 comprises a depression with a groove 12 running on the border of the latter in each case, perpendicularly to the alignment of the handle 2, said groove 12 providing the head part 1 with a certain level of elasticity or resilient action, as do also the grooves 12' running on the lateral border of the head part. The prepared region 13 is slightly smaller than the basic surface area of the carrier element 5, with the result that the latter can be fitted into the region 13 in a clamping manner. As can be seen from the plan view in figure 5e, the additional part has both rod-like cleaning elements and sheet-like cleaning

- 12 -

elements arranged transversely to the alignment of the handle 2.

Figures 6a-f show a further example of a toothbrush according to the invention, in this case a plug-on toothbrush for an electric teeth-cleaning unit. The conventional clusters of bristles 3 are fastened on a separate bristle plate 18 which, in the assembled state, is connected to the matching head part 1 of the toothbrush or a disc 23 which is fastened in a rotatable or pivotable manner thereon. The flexible cleaning elements 6, which are rod-like in this case, are fastened on a carrier element 5 which is slightly curved in plan view and has a sheet-like extension 16, which is oriented essentially perpendicularly to the alignment of the cleaning elements 6. The additional part 4 can be introduced, by way of said extension 16, into a correspondingly shaped groove 14 in the disc 23. Arranged in the center of the head part 1 and of the groove 14 is a round cutout 15, in which a corresponding mating element 17 on the extension 16 of the additional part 4 engages. The additional part 4 and head part 1 are thus connected to one another in a well-fitting and clamping manner. At its bottom end, the bristle plate 18 has a groove 19 by means of which the bristle plate 18 can be fastened on the disc 23 or the lateral extensions 23a thereof. In the embodiment illustrated, the additional part 4 is moved along by the disc 23. As an alternative, it is possible for the additional part 4 to be fastened directly on the head part 1 and not to rotate as well.

Figures 7a-e show an example of the production of a toothbrush by means of AFT technology. Figures 7a-c show sectional views of the carrier element 5 in various process stages, to be precise before being provided with flexible cleaning elements 6 and conventional clusters of bristles 3 (figure 7a), following the application of the flexible material

- 13 -

(figure 7b) and following the application of the bristles (figure 7c). The outer shape of the carrier element 5 is adapted to the dimensions of a prepared region 13 in the form of a shallow cutout in the head part 1 of the toothbrush. The carrier element 5 has prepared regions 20, into which the flexible cleaning elements 6 are fitted, in particular molded. Furthermore, the carrier element 5 has cutouts 24, which are filled wholly or partially with flexible material 6', see also the detail from figure 7e. The carrier element 5 also contains holes 21, through which clusters of bristles 3 are plugged and are fastened on the rear side by virtue of their rear ends 3a being incipiently melted. The elastic material regions 6' have further holes 21' which likewise serve for accommodating clusters of bristles 3, which are fastened in the same way. The material regions 6' can accommodate one or more clusters of bristles 3. The clusters of bristles 3 anchored in the elastic material 6' are thus anchored or suspended in a particularly elastic manner. Further clusters of bristles 3 are fastened directly on the carrier element 5. The carrier element 5 fitted with clusters of bristles and the flexible structure 6, 6' is then inserted into the prepared region 13.

The edge 30 of the carrier element 5, this edge in the application case being directed towards the base of the cutout 13, is tapered, just as in the example from figures 10 and 11. This tapering edge 30 serves, during ultrasonic welding for connection to the head part 1, as an energy concentrator and a material reservoir for material which is to be liquefied.

The AFT technology manages without anchors or clips for fastening the bristle filaments, which instead are welded directly on the carrier plate. This means that the width of a cluster of bristles is not determined by the anchor, with the result that it is also possible to

- 14 -

realize finer structures, in particular also sheet-like bristle arrangements.

5 It is technically also possible, in the case of AFT, to prepare the bristle filaments for use before they are fitted on the carrier plate. The variant which is realized at present, however, is that where the bristles are only machined once they have been fitted on the carrier plate.

10

Figures 8a-e show a variant of the toothbrush from figure 4. The bristle arrangement made of conventional clusters of bristles 3 corresponds to figure 4. The additional part 4 has a plurality of pin-like cleaning
15 elements 6 which diverge in the form of a star and engage through the conventional clusters of bristles 3 (figures 8d and e). The fastening mechanism corresponds to figure 4. A layer 22' made of flexible material covers the underside of the head and handle parts 1, 2.

20

Figures 9a-f show a further example of a toothbrush according to the invention. The head part 1 has a prepared region 13 for the carrier element 5 of the additional part 4, said region being larger than the
25 carrier element 5 itself. The region 13 is, for example, a hole which passes all the way through the head part 1, see sectional drawings from figures 9b, d and e. The region 13 has two lateral grooves 13a, the shape of which is adapted to the shape of two lateral
30 extensions 5b of the carrier element 5. The latter is inserted into the head part 1 and latches there. The play of the carrier element 5 within the region 13, which allows lateral displacement and/or a pivoting
35 results in a particular level of elasticity or resilient action of the additional part 4. The rear side of the head part 1, again, may be covered by a layer of soft material.

- 15 -

Figures 10a-j show a further example of a toothbrush produced by means of AFT. Figures 10a-c correspond to figures 7a-c and each show the carrier plate 5 in various process stages. Figures 10d-f show the same carrier plate 5 in section along line I-I indicated in figure 10a. The centrally arranged flexible element 6 is sheet-like or sail-like and is undulating in plan view (figure 10h). As is illustrated in figures 10e and f, the flexible structure comprises laterally integrally formed regions 6'' which, in the assembled state (figure 10h), bound the toothbrush head 1 laterally and terminate more or less flush with the outer contour of the head part. They serve, for example, as impact protection and/or for additionally massaging the gums. The regions 6'' likewise have holes 21' for accommodating clusters of bristles 3, which are thus suspended in an elastic manner and are particularly compliant during cleaning.

The carrier element 5 provided with conventional bristles 3 and the flexible structure 6, 6', 6'' is inserted into a cutout 13 in the brush head 1. The brush head 1 is illustrated in various views without the carrier element 5 in figures 10g and j and with the carrier element 5 inserted in figures 10h and i. On its lateral border, the brush head 1 or the cutout 13 has lateral openings 25, which are adapted to the lateral flexible regions 6'' previously molded on the carrier element 5.

The carrier element 5 is connected to the brush head 1 by means of ultrasonic welding. The welding surface 26 is indicated by dashed lines. In order to realize the welding, the carrier element has, on its bottom border, a welding border 26' which, during assembly, rests on the base of the cutout 13, the contact surface defining the welding surface 26. The welding border 26' melts under the influence of ultrasound, with the result that the two parts 5 and 1 are connected to one another.

- 16 -

Since elastomeric material can only be welded ultrasonically to a limited extent, the welding surface 26, as far as possible, is kept free of this material, for example as in the case of the toothbrush from figure 7 or, with only minimal interruptions, as in the case of the toothbrush from figure 10. The aim, in both cases, is to seal the cavity 28 between the carrier element 5 and head part 1 to the full extent, in order to prevent the ingress of water and germs. For this purpose, the injection point of the flexible material is preferably selected to be on the bristle-carrying front side of the carrier element 5, in order that no unnecessary material bridges reduce the size of the welding surface 26. If further flexible elements are provided on the head part 1, in particular on the rear side thereof, they are positioned such that they do not reduce the size of the welding surface 26. For example, these elements and the corresponding injection point are located fully within that region on the rear side of the head part 1 (not illustrated) which is defined by the welding surface 26. The entire contact surface between the head part 1 and carrier element 5 is preferably welded over at least 25%, particularly preferably along the periphery of the head (line 26).

In the example from figure 10, the flexible regions 6'' interrupt the welding surface 26, with the result that non-welded locations 27 are produced there. These are advantageously arranged on the side of the head part 1, while the longitudinally front and rear regions of the carrier element 5 are firmly welded to the head part 1. This ensures that the carrier element 5 is held securely since the front and rear regions are subjected to an extremely high level of loading by the cleaning movement and corresponding leverages.

The non-welded locations 27 are sealed by the flexible regions 6'' here in the manner of a sealing lip, with

- 17 -

the result that only a very small amount of water, if any at all, can penetrate into the cavity 28. For a good sealing function, material with a Shore A hardness of 50 or less is preferably selected. Non-welded
5 locations between the head part and carrier element may also be used specifically, in order to achieve a certain level of flexibility between the two hard components.

10 Figure 11 shows various views of a further example of a toothbrush produced by AFT, in this case, with two sail-like flexible cleaning elements 6. The carrier element 5 is fully enclosed, around its periphery, by flexible material 6', which, in the assembled state
15 (plan-view illustration figure 11a) fully encloses the outer periphery of the head part 1 on the top side and serves as impact protection. In regions 6'', the soft material serves as a mount for lateral clusters of bristles 3 which are guided through the flexible
20 material 6''.

As can be gathered from figure 11c, the hard components (carrier element 5 and head part 1) come into contact with one another along a surface 26 beneath the soft
25 component in the region 6' and can be welded here by means of ultrasound. The welding surface 26 is interrupted by the lateral regions 6'', although, as has been described above, a sufficient retaining action is achieved. The cavity 28 beneath the carrier element
30 5 is sealed by the flexible regions 6'' and the locations welded along the surface 26.

The method of welding and sealing the components which has been described above with reference to figures 10
35 and 11 may also advantageously be used for other toothbrushes.

Patent Claims

1. A toothbrush having a handle and a head part with bristle filaments and a flexible structure of a first soft material, wherein the flexible structure is arranged on a carrier element which consists of a second hard material and is connected to the head part, such that a rear side of the carrier element faces the head part and wherein bristle filaments are guided through cutouts in the carrier element and/or in the flexible structure and, for fastening by its rear ends facing the head part, are melted, welded or adhesively bonded.
2. The toothbrush as claimed in claim 1, wherein the flexible structure comprises at least one flexible cleaning element.
3. The toothbrush as claimed in claim 1 or 2, wherein the flexible structure and the carrier element are produced by two-component or multi-component injection molding.
4. The toothbrush as claimed in claim 3, wherein a non-releasable connection is provided between the flexible structure and the carrier element.

- 19 -

5. The toothbrush as claimed in any one of claims 1 to 4, wherein the material of the carrier element is polypropylene (PP), styrene-acrylonitrile (SAN), acrylonitrile-butadiene-styrene (ABS), Isoplast® or polyester (PET).
6. The toothbrush as claimed in any one of claims 1 to 5, wherein the carrier element is inserted into a cutout in the head part adapted to the shape of the carrier element and connected in a non-releasable manner to the head part.
7. The toothbrush as claimed in any one of claims 1 to 6, wherein the flexible structure consists of natural or synthetic rubber.
8. The toothbrush as claimed in claim 7, wherein the flexible structure consists of a thermoplastic elastomer.
9. The toothbrush as claimed in claim 7 or 8, wherein the flexible structure has a Shore A hardness of less than 90.
10. The toothbrush as claimed in claim 7 or 8, wherein the flexible structure has a Shore A hardness of less than 50.

- 20 -

11. The toothbrush as claimed in any one of claims 1 to 10, wherein a cavity exists between the carrier element and the head part.
12. The toothbrush as claimed in any one of claims 1 to 11, wherein connecting locations between the head part and the carrier element are covered by flexible material.
13. The toothbrush as claimed in claim 12, wherein the connecting locations are covered by sealing against entry of water.
14. The toothbrush as claimed in any one of claims 1 to 13, wherein the flexible structure comprises regions arranged laterally on the carrier element, said regions terminating laterally with the outer contour of the head part.
15. The toothbrush as claimed in claim 14, wherein the regions of the flexible structure arranged laterally on the carrier element seals not welded locations between the head part and the carrier element against the entry of water.
16. The toothbrush as claimed in claim 14 or 15, wherein the head part and a cutout respectively comprise lateral openings whose shape is adapted to the flexible regions arranged laterally on the carrier element.

- 21 -

17. The toothbrush as claimed in any one of claims 1 to 16, wherein the carrier element comprises an edge on its rear side which faces the head part, acts as a welding border and acts as a material reservoir and/or energy concentrator, whereby a contacting area defines a welding surface.
18. The toothbrush as claimed in claim 17, wherein the edge of the carrier element is sharp.
19. The toothbrush as claimed in claim 17 or 18, wherein the flexible structure is arranged within the area defined by the welding surface.
20. The toothbrush as claimed in claim 17 or 18, wherein the welding surface is kept free of the flexible material.
21. The toothbrush as claimed in any one of claims 1 to 20, wherein the flexible structure comprises plane elements arranged on the carrier element.
22. The toothbrush as claimed in any one of claims 1 to 21, wherein the carrier element comprises prepared regions and/or cutouts for the acceptance of the flexible structure.

- 22 -

23. The toothbrush as claimed in any one of claims 1 to 22, wherein a plurality of cutouts receiving bristle filaments are arranged in a common section of the flexible structure.

24. A process for producing a toothbrush as claimed in any one of claims 1 to 23, the process comprising:

attaching at least one flexible structure of a first soft material to a carrier element which consists of a second hard material;

guiding bristle filaments through cutouts in the carrier element and/or in the flexible structure;

fastening the bristle filaments at the carrier element and the flexible structure, respectively, by melting, welding or adhesively bonding their rear ends; and

connecting the carrier element to the head part.

25. The process as claimed in claim 24, wherein the carrier element and the head part are connected to one another in a non-releasable manner by clamping, snap-fitting, riveting, adhesive bonding, welding, ultrasonic welding or the supply of heat.

- 23 -

26. The process as claimed in claim 24 or 25, further comprising cutting and/or rounding and/or preparing for use in some other way the bristle filaments before fastening the carrier element to the head part or attaching the bristle filaments to the carrier element.
27. The process as claimed in one of claims 24 to 26, further comprising producing the flexible structure and the carrier element by two-component injection molding before connecting to the head part.
28. The process as claimed in claim 27, wherein a non-releasable connection is produced between the flexible structure and the carrier element.
29. The process as claimed in claim 27, wherein an injection point of the flexible material is selected on the front side of the carrier element.
30. The process as claimed in any one of claims 24 to 29, wherein connecting the carrier element to the head part comprises inserting the carrier element into a cutout in the head part and connecting the carrier element in a non-releasable manner to the head part by ultrasonic welding.

- 24 -

31. The process as claimed in any one of claims 24 to 30, wherein connecting the carrier element to the head part comprises welding a contacting area between the head part and the carrier element at an extent of at least 25% of the contacting area.
32. The process as claimed in claim 31, wherein the contacting area is welded along the whole circumference of the head part.
33. The process as claimed in any one of claims 24 to 30, wherein connecting the carrier element to the head part comprises just welding the head part and the carrier element together in a front and a rear region, as seen in the longitudinal direction.
34. The process as claimed in any one of claims 24 to 33, further comprising covering not welded locations between the head part and the carrier element with flexible material.
35. The process as claimed in claim 34, wherein the not welded locations are covered in a manner against the entry of water.

36. A carrier element for a toothbrush, comprising: a flexible structure attached to a plate-like carrier element having a front side and a rear side, the carrier element being of a harder material than the flexible structure, the carrier element comprising an edge-like welding border, bristle receiving cutouts are provided in the carrier element and/or the flexible structure, bristle filaments are guided through the bristle receiving cutouts, and rear ends of the bristle filaments are melted, welded or adhesively bonded on the rear side of the carrier element or the flexible structure.
37. The carrier element as claimed in claim 36, wherein the flexible structure comprises at least one flexible, non-bristle containing cleaning element.
38. The carrier element as claimed in claim 37, wherein the carrier element comprises at least one cleaning element receiving cutout extending at least partially through the carrier element in which said non-bristle containing cleaning element is anchored.
39. The carrier element as claimed in claim 37, wherein the non-bristle containing cleaning element comprises sheet-like elements that are arranged centrally on the carrier element.

- 26 -

40. The carrier element as claimed in claim 36, wherein the carrier element is formed to be inserted and welded into a carrier element receiving cutout of a head part of the toothbrush.
41. The carrier element as claimed in claim 36, wherein a welding border defining a welding surface between the carrier element and a head part of the toothbrush is kept free of the flexible component.
42. The carrier element as claimed in claim 36, wherein flexible regions interrupt a welding surface, with the result that non-welded locations are present.
43. The carrier element as claimed in claim 42, wherein the non-welded locations are produced on a lateral side.
44. The carrier element as claimed in claim 36, wherein the longitudinally front and rear regions of the carrier element are firmly welded to a head part of the toothbrush.
45. The carrier element as claimed in claim 36, wherein non-welded locations between a head part of the toothbrush and the carrier element are used specifically, in order to achieve a certain level of flexibility between the hard components of the carrier element and of the head part.

- 27 -

46. The carrier element as claimed in claim 36, wherein non-welded locations between a head part of the toothbrush and the carrier element are used in order that the head part and the carrier element can be moved in relation to one another.
47. The carrier element as claimed in claim 36, wherein the flexible structure and the carrier element are produced by multi-component injection molding and mated with a non-releasable connection.
48. The carrier element as claimed in claim 36, wherein an injection point for producing the flexible structure is located on the front side.
49. The carrier element as claimed in claim 36, wherein the flexible structure comprises natural or synthetic rubber.
50. The carrier element as claimed in claim 36, wherein the flexible structure comprises a thermoplastic elastomer.
51. The carrier element as claimed in claim 36, wherein the flexible structure has a Shore A hardness of less than 90.

- 28 -

52. The carrier element as claimed in claim 36, wherein at least one of the bristle receiving cutouts is arranged in the flexible structure and provided with bristle filaments that are anchored to the flexible structure in an elastic manner.
53. The carrier element as claimed in claim 36, further comprising bristle receiving cutouts arranged directly in the carrier element, the cutouts being provided with bristle filaments.
54. The carrier element as claimed in claim 36, wherein the flexible structure comprises regions arranged laterally on the carrier element, said regions terminating laterally with the outer contour of a head part of the toothbrush or projecting beyond the head part when the carrier element is attached to the head part.

- 29 -

55. A carrier element for a toothbrush, comprising: a flexible structure attached to a plate-like carrier element having a front side and a rear side, the carrier element being of a harder material than the flexible structure, the flexible structure comprising at least one flexible, non-bristle containing cleaning element, bristle receiving cutouts are provided in the carrier element and/or the flexible structure, bristle filaments are guided through the bristle receiving cutouts, and rear ends of the bristle filaments are melted, welded or adhesively bonded on the rear side of the carrier element or the flexible structure.
56. A carrier element for a toothbrush, comprising: a flexible structure attached to a plate-like carrier element having a front side and a rear side, the carrier element being of a harder material than the flexible structure, wherein the flexible structure comprises regions arranged laterally on the carrier element, bristle receiving cutouts are provided in the carrier element and/or the flexible structure, bristle filaments are guided through the bristle receiving cutouts, and rear ends of the bristle filaments are melted, welded or adhesively bonded on the rear side of the carrier element or the flexible structure.

- 30 -

57. A carrier element for a toothbrush, comprising: a flexible structure attached to a plate-like carrier element having a front side and a rear side, the carrier element being of a harder material than the flexible structure, the flexible structure comprising at least one flexible, non-bristle containing cleaning element, the carrier element comprises at least one cleaning element receiving cutout extending at least partially through the carrier element, in which said non-bristle containing cleaning element is anchored, bristle receiving cutouts are provided in the carrier element and/or the flexible structure, bristle filaments are guided through the bristle receiving cutouts, and rear ends of the bristle filaments are melted, welded or adhesively bonded on the rear side of the carrier element or the flexible structure.

58. A toothbrush comprising a carrier element as claimed in claim 36.

59. A method for producing a carrier element comprising: providing a carrier element having a front side and a rear side;

attaching a flexible structure to the carrier element, wherein the carrier element is made from a harder material than that of the flexible structure;

- 31 -

providing a plurality of bristle filaments and guiding them through bristle receiving cutouts in the carrier element and/or in the flexible structure; and

fastening rear ends of the bristles on a rear side of the carrier element and/or the flexible structure by melting, welding or adhesive bonding.

60. The method as claimed in claim 59, further comprising cutting and/or rounding the bristle filaments before fastening of the bristles to the carrier element and/or the flexible structure.
61. The method as claimed in claim 59, comprising producing the flexible structure and the carrier element by two-component injection molding.
62. The method as claimed in claim 59, comprising producing a non-releasable connection between the flexible structure and the carrier element.
63. The method as claimed in claim 59, further comprising providing an injection point of the flexible material on the front side of the carrier element.
64. A method for producing a toothbrush comprising a carrier element as claimed in claim 36 wherein the carrier element is non releasably connected to a head part of the toothbrush.

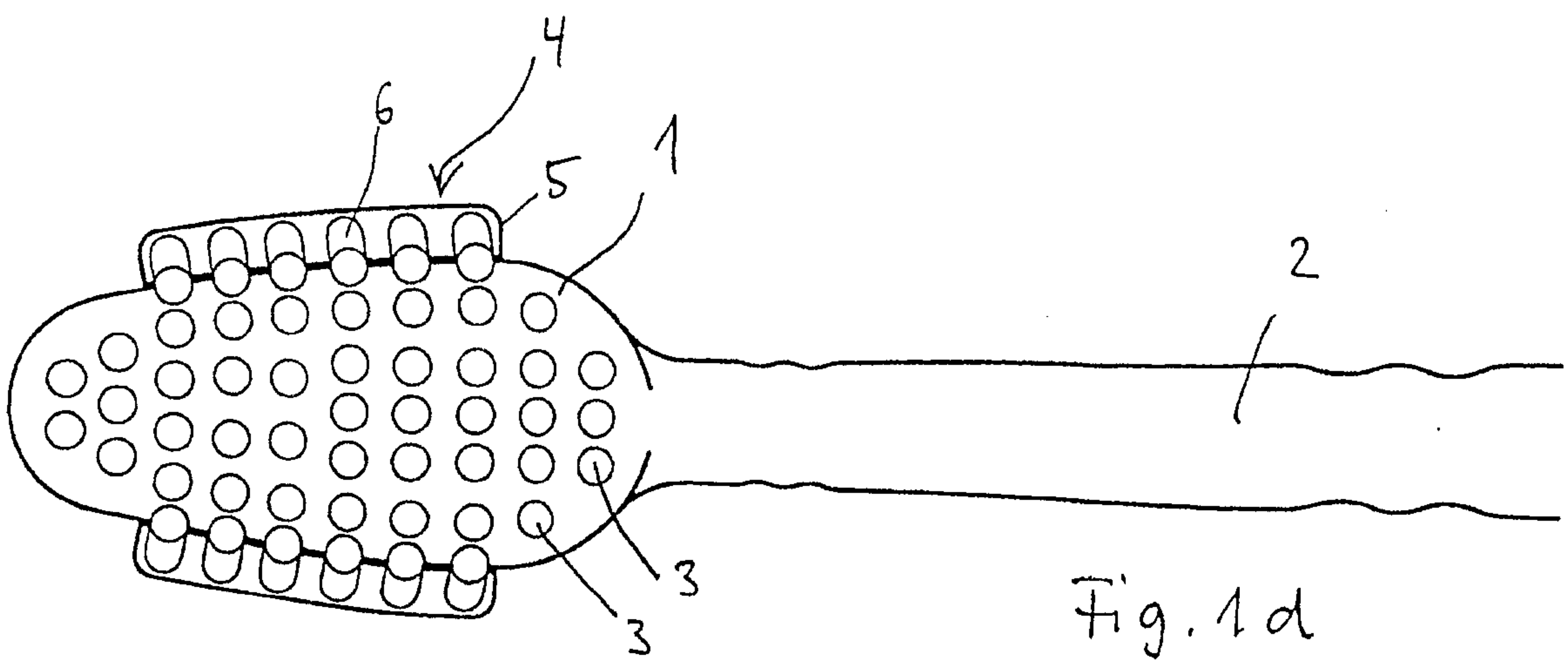
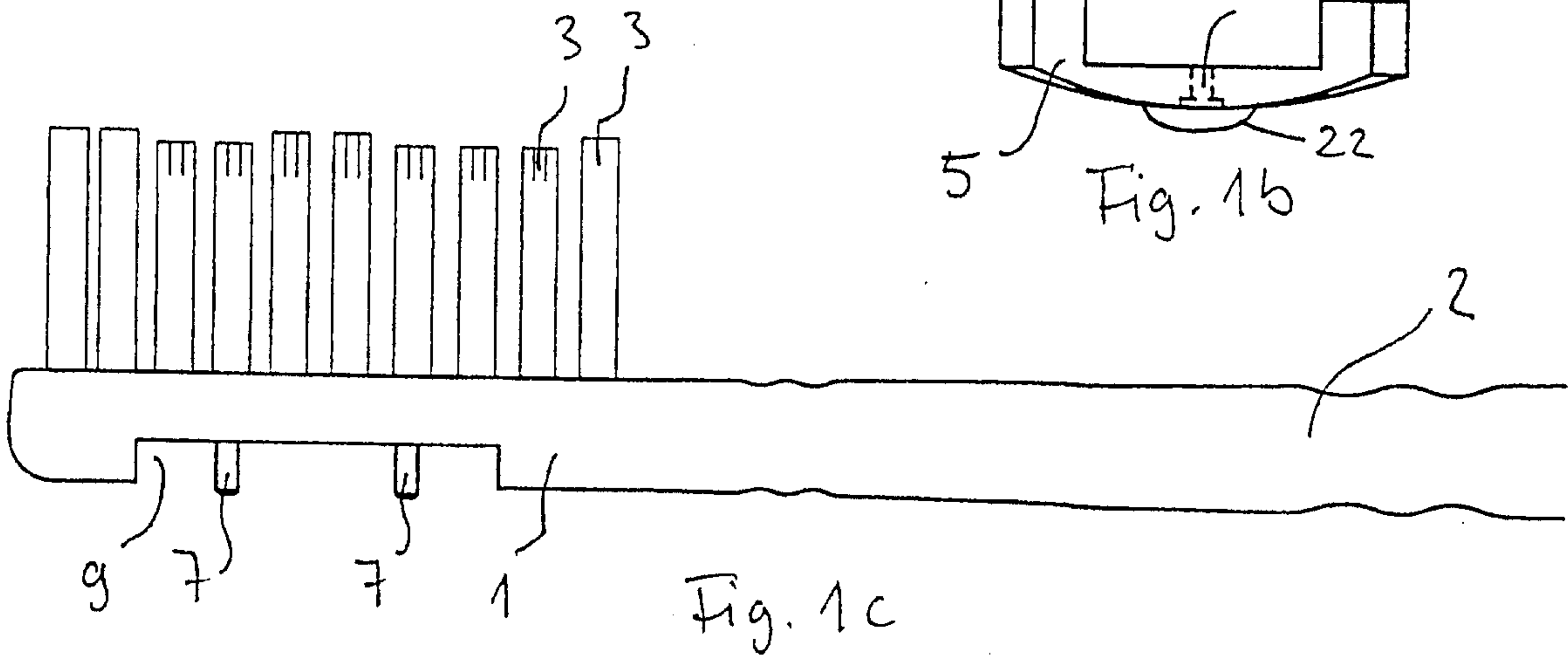
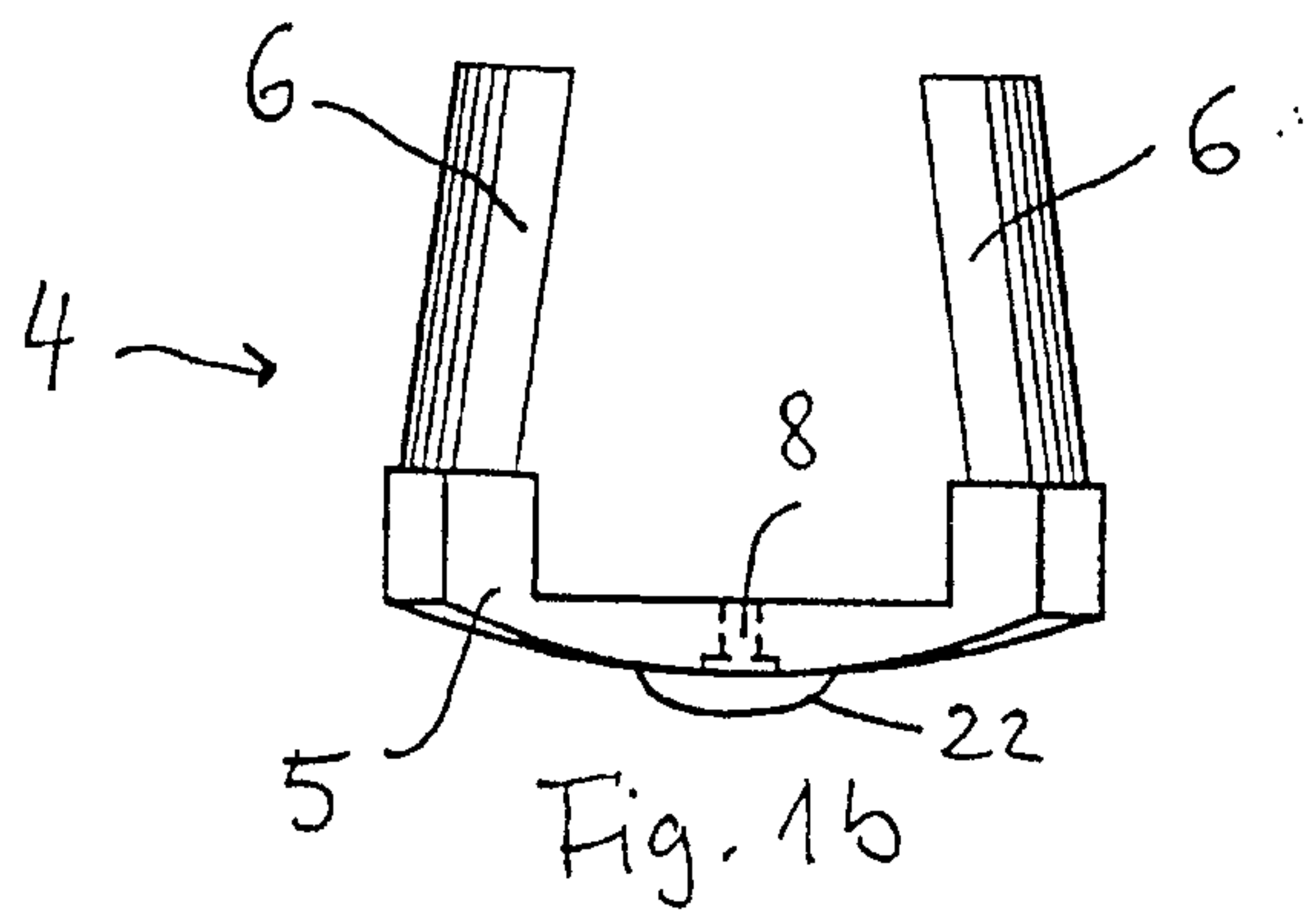
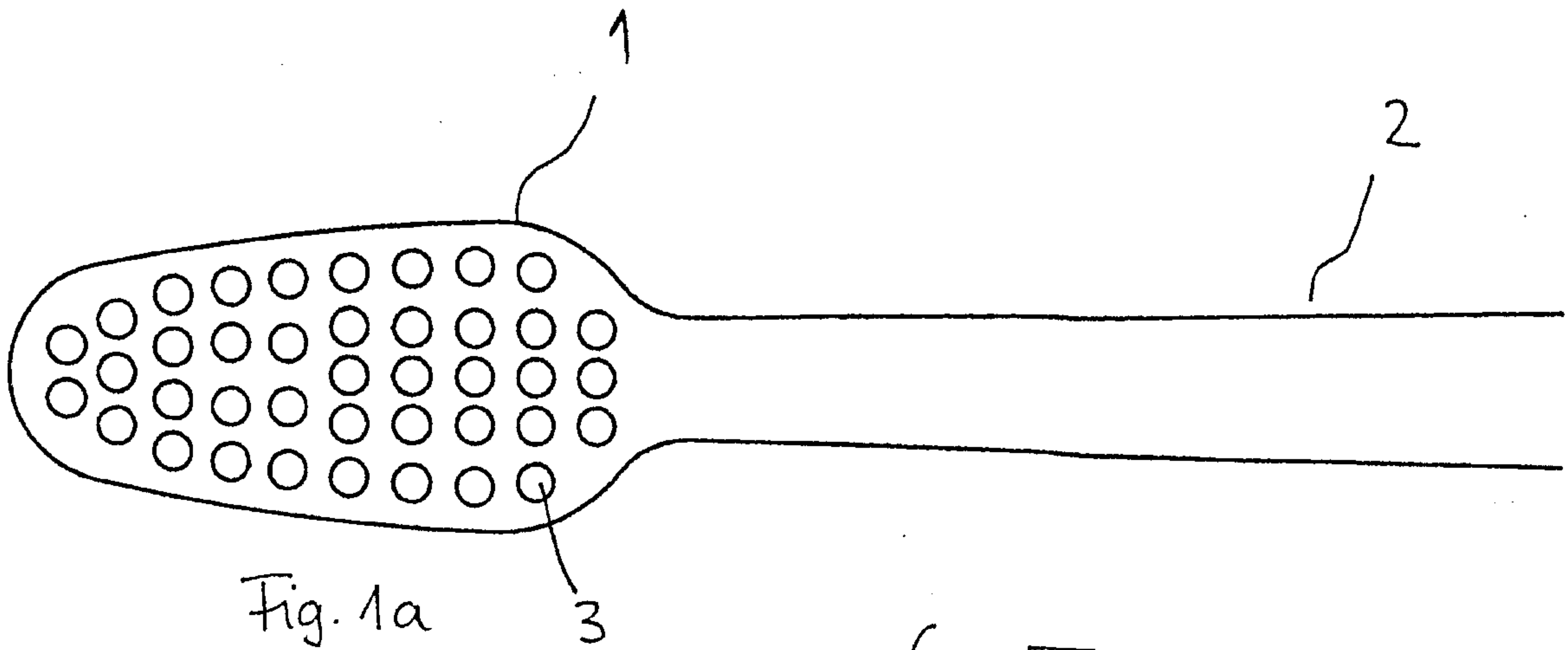

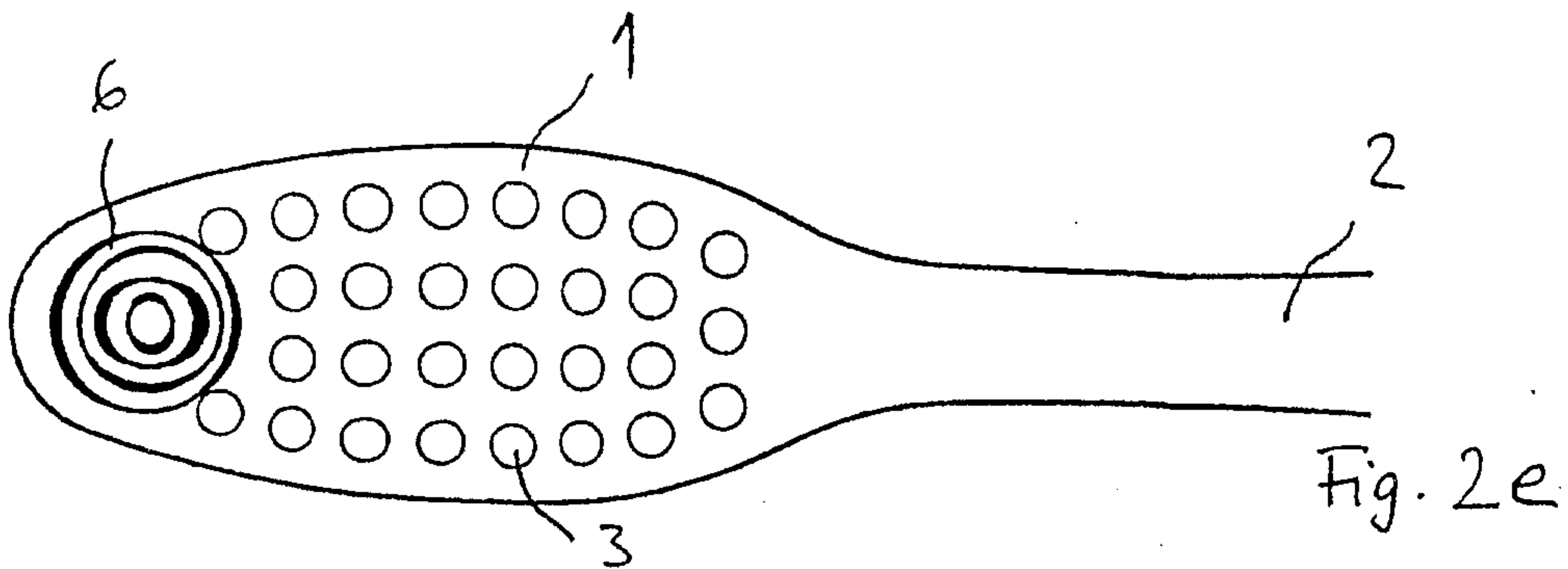
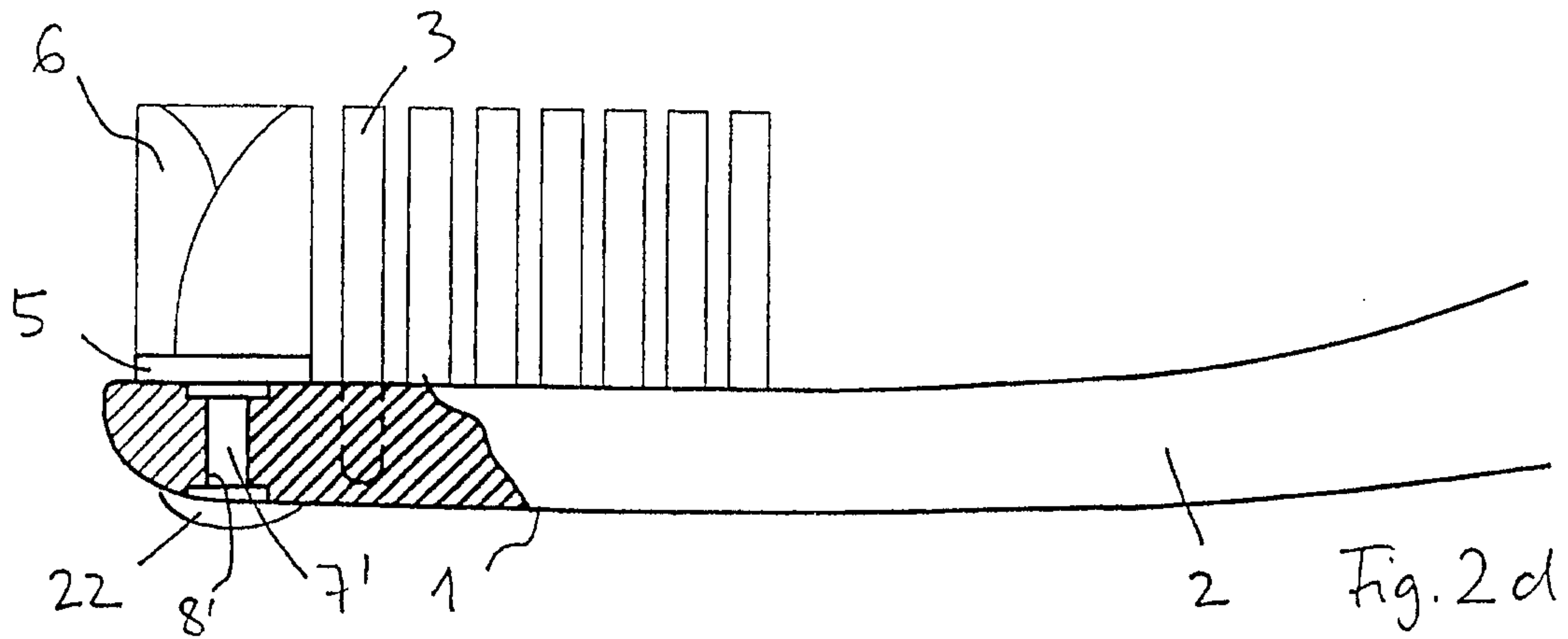
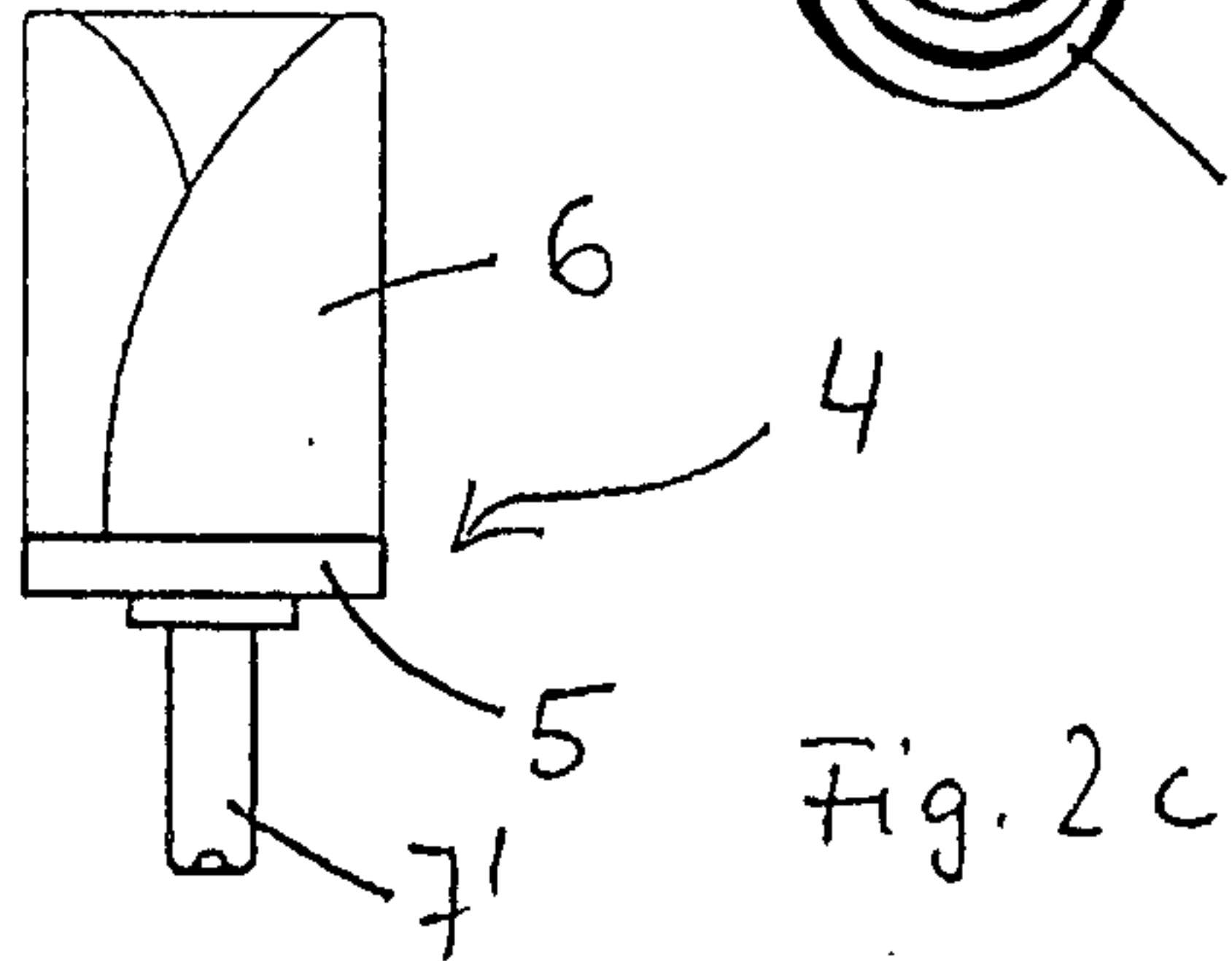
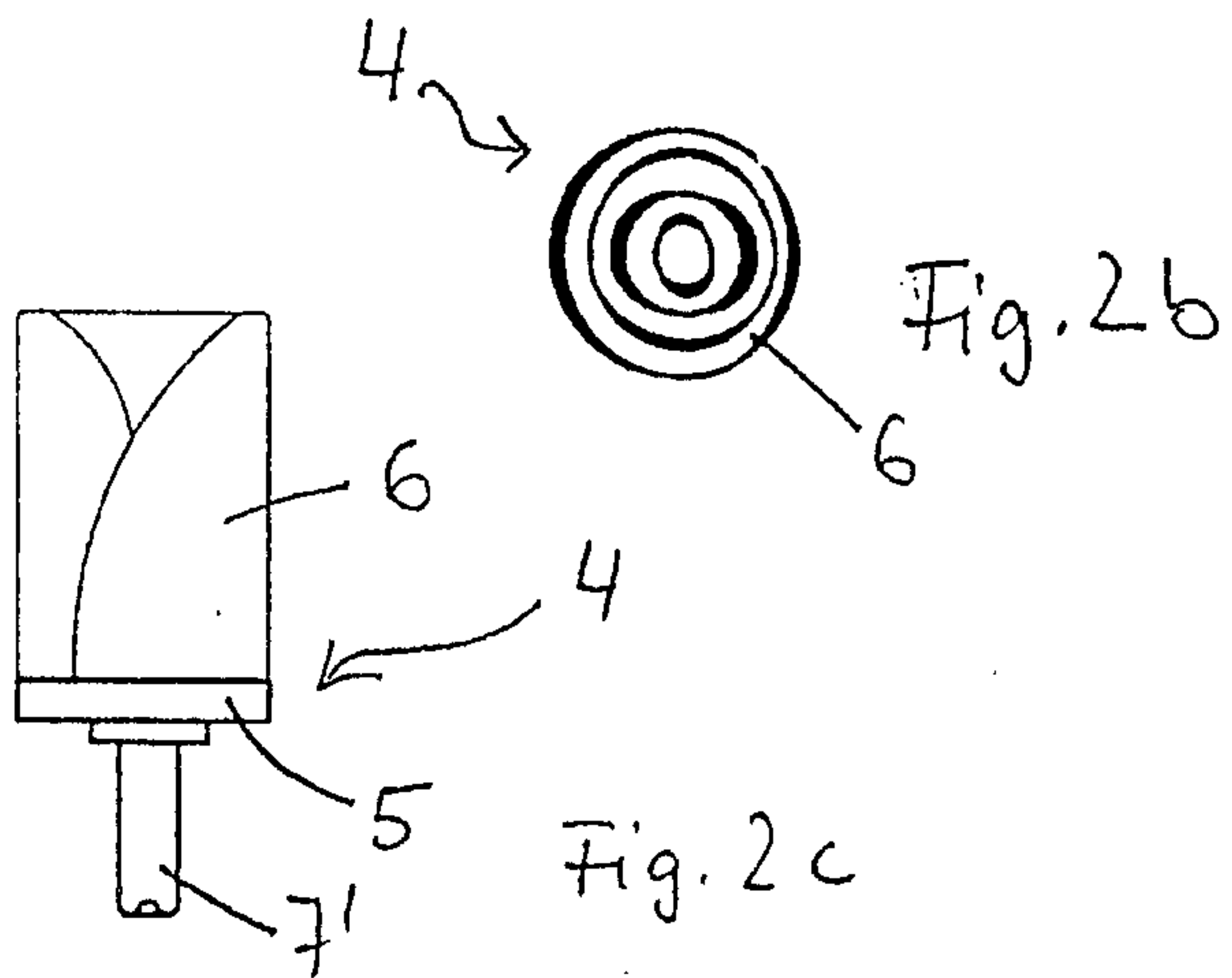
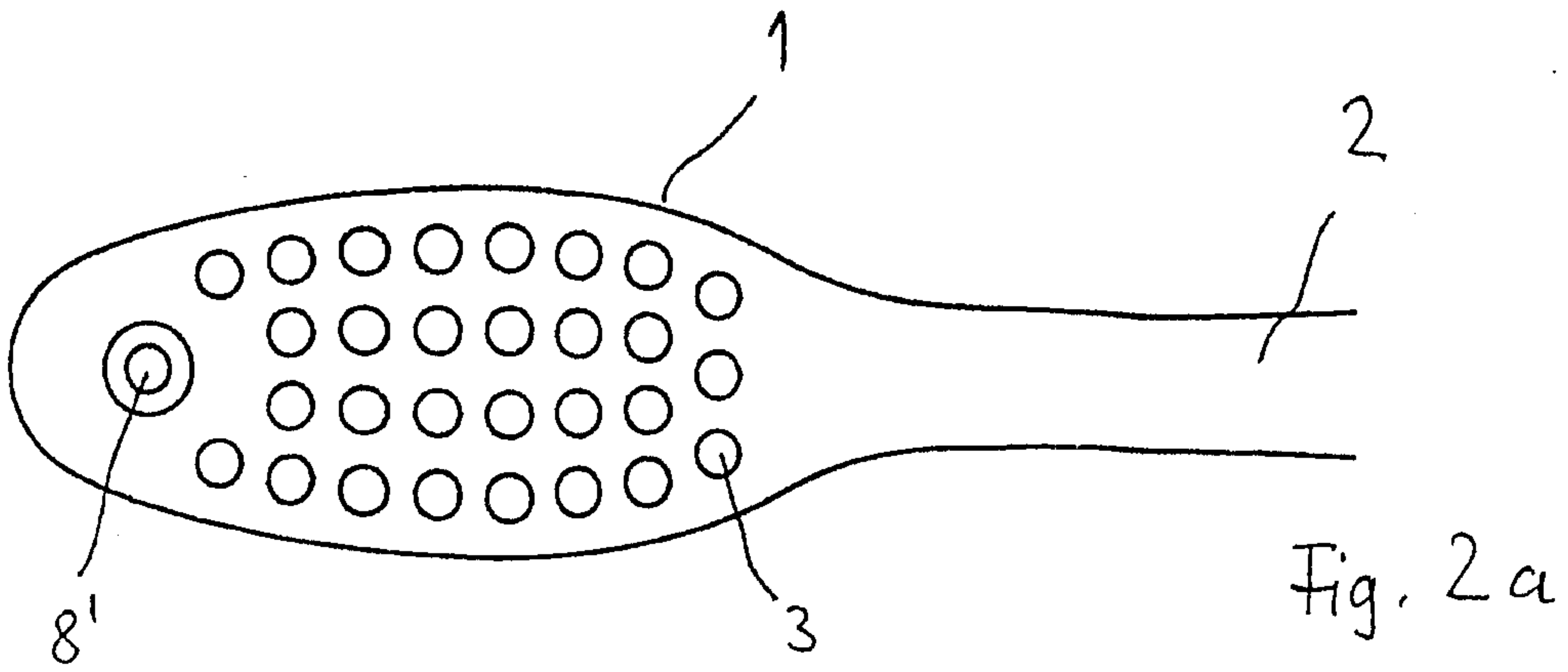

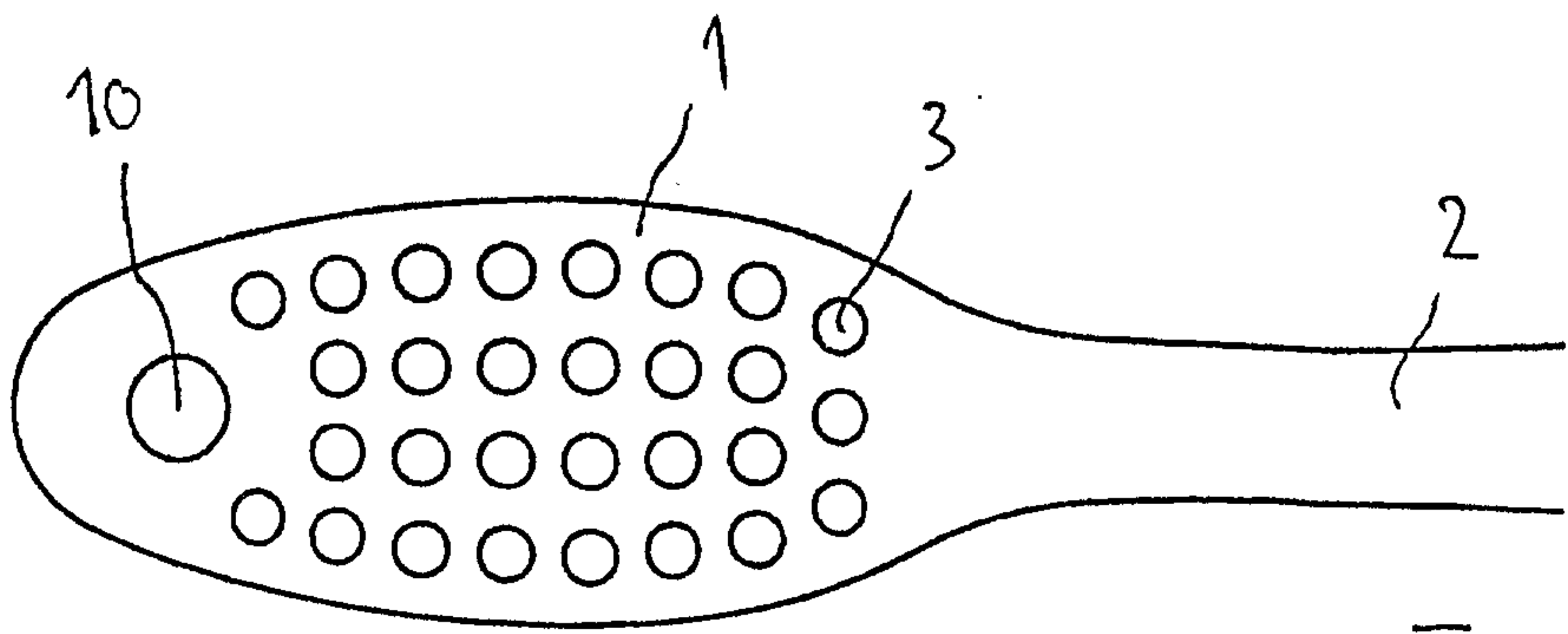

Fig. 3a

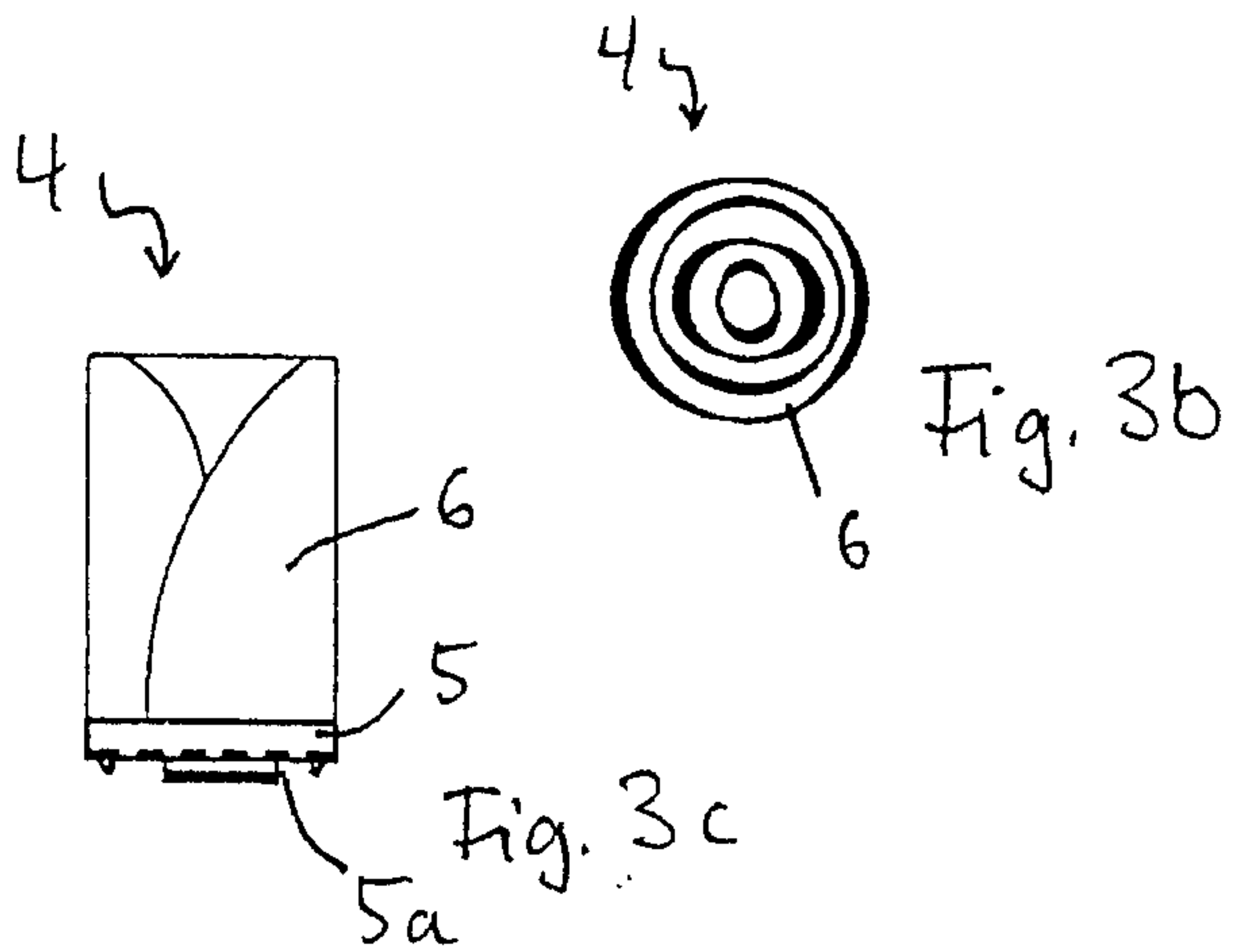

Fig. 3b

Fig. 3c

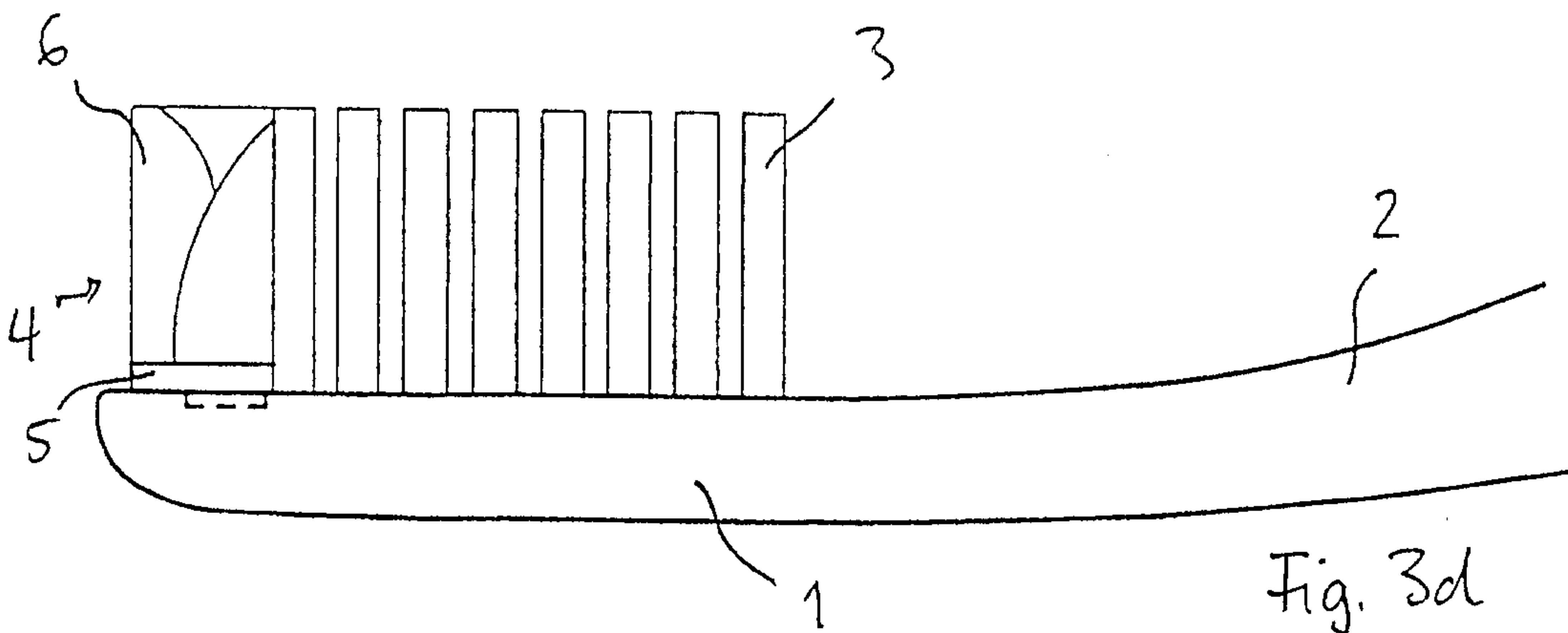

Fig. 3d

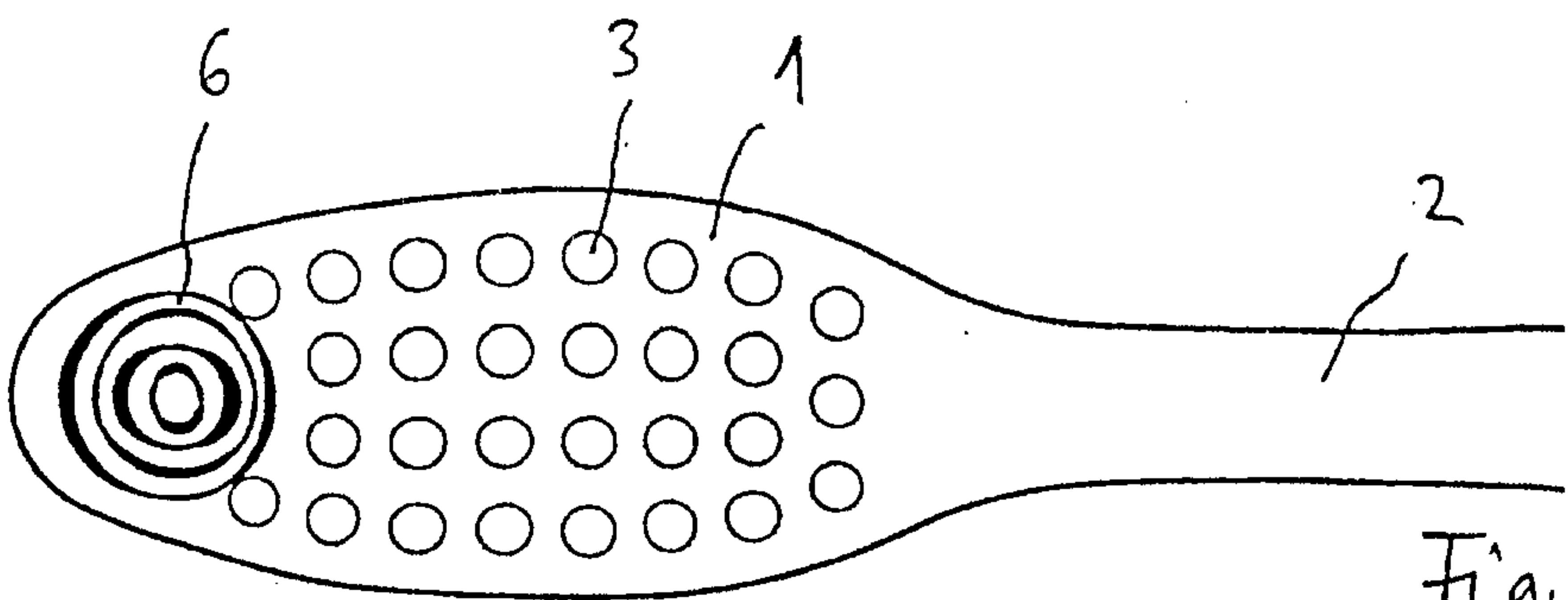
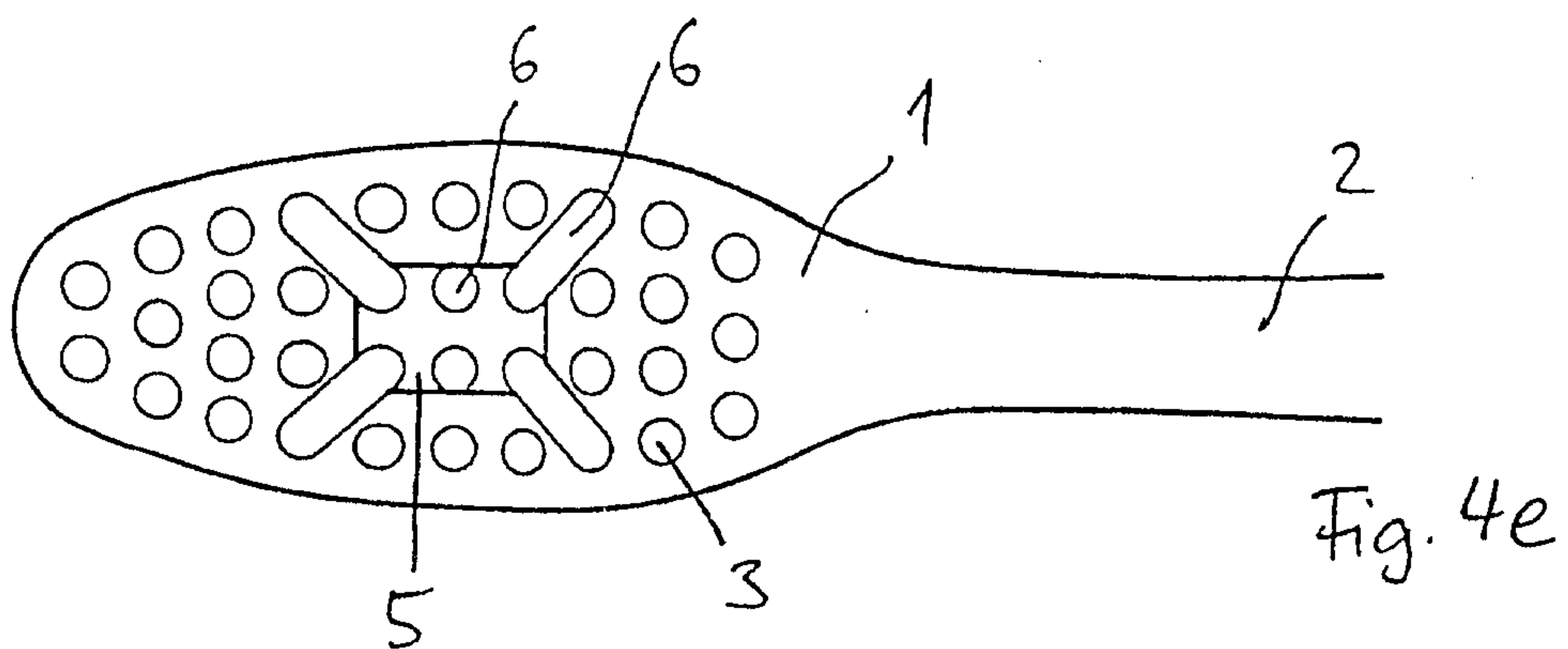
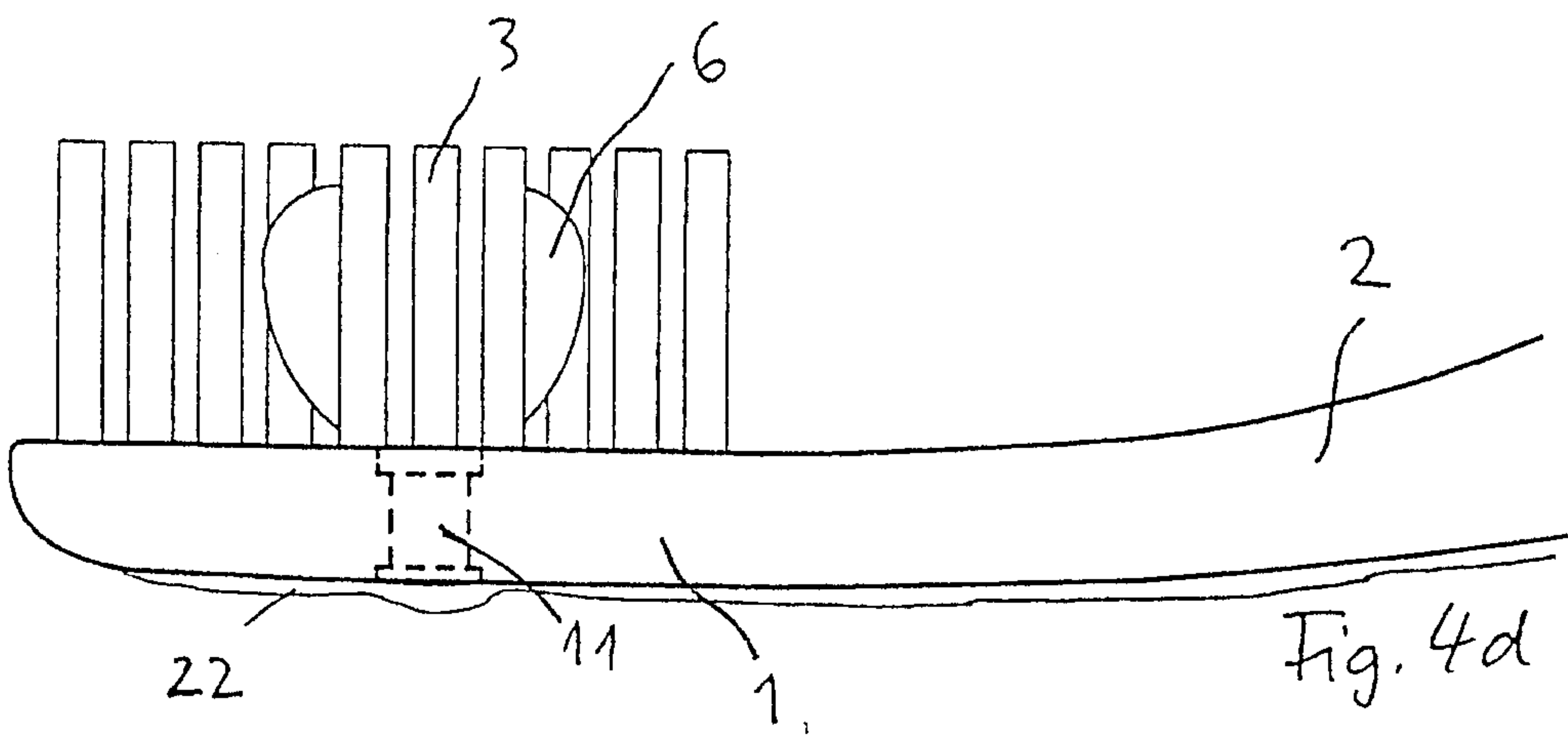
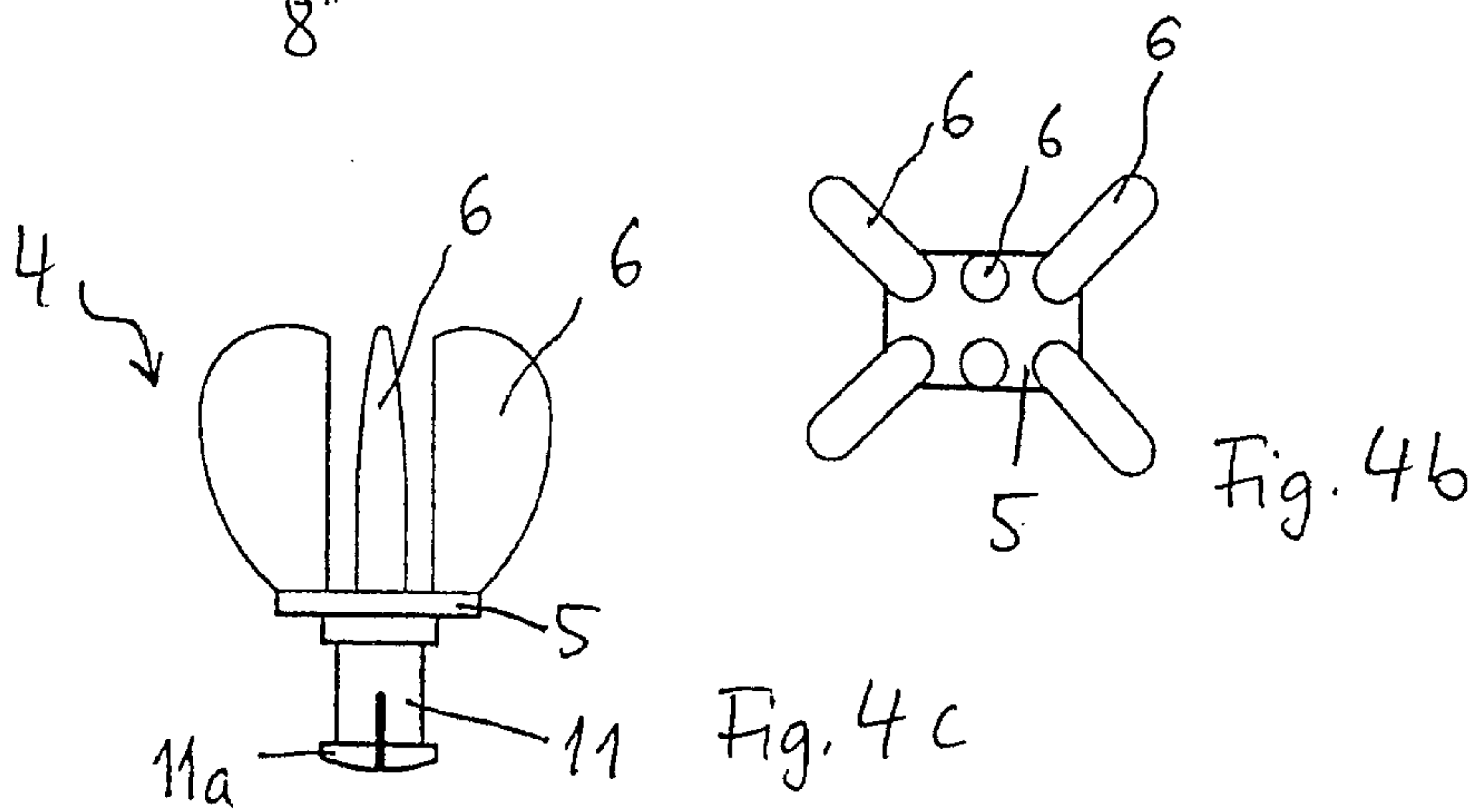
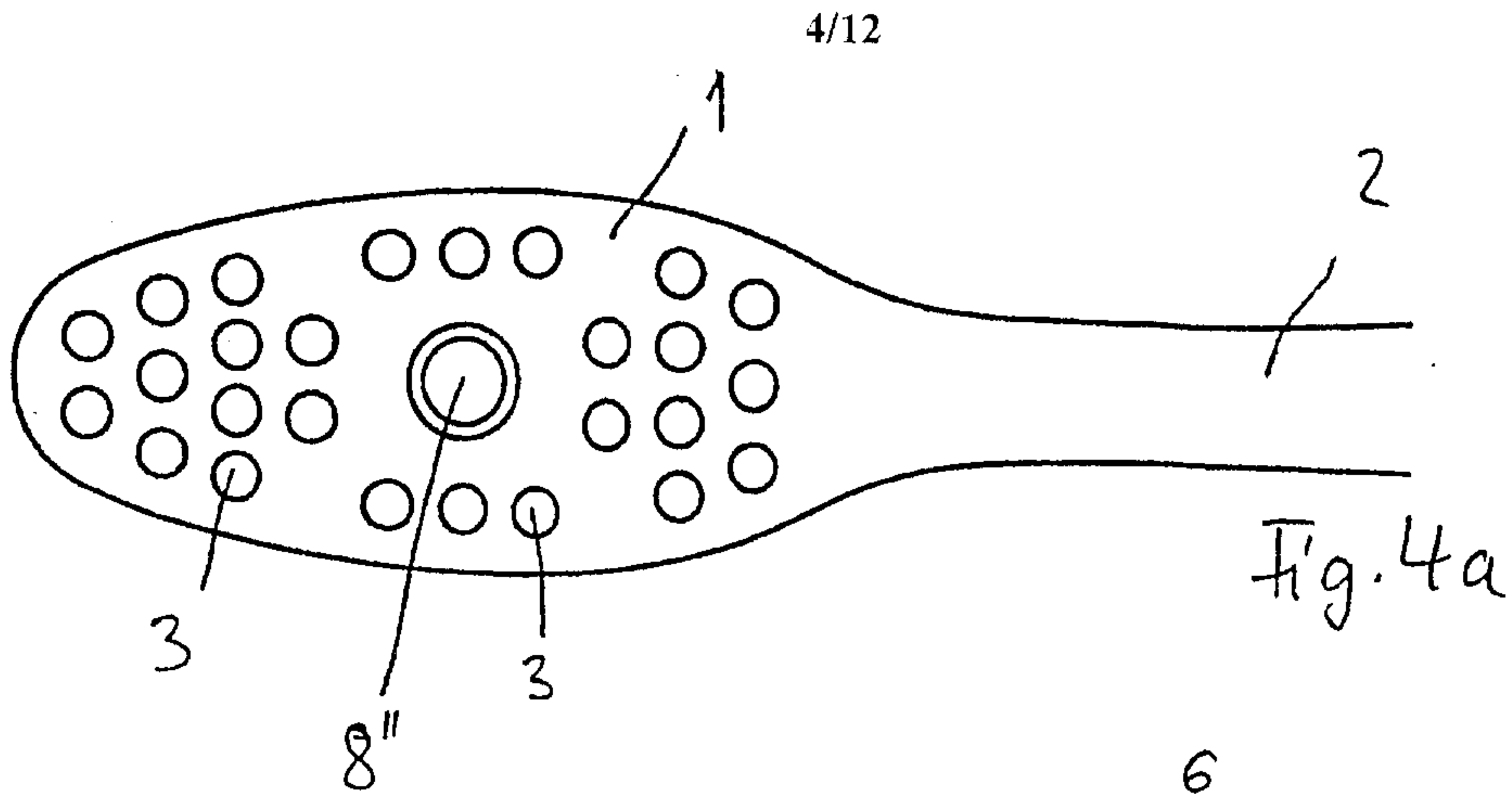
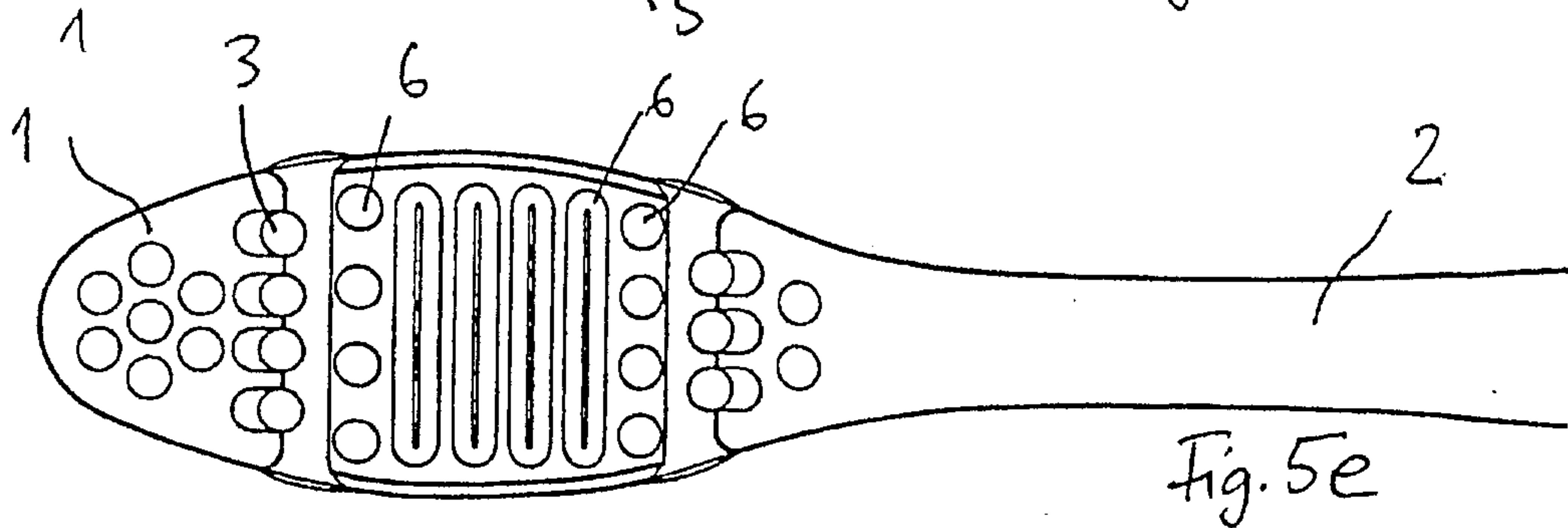
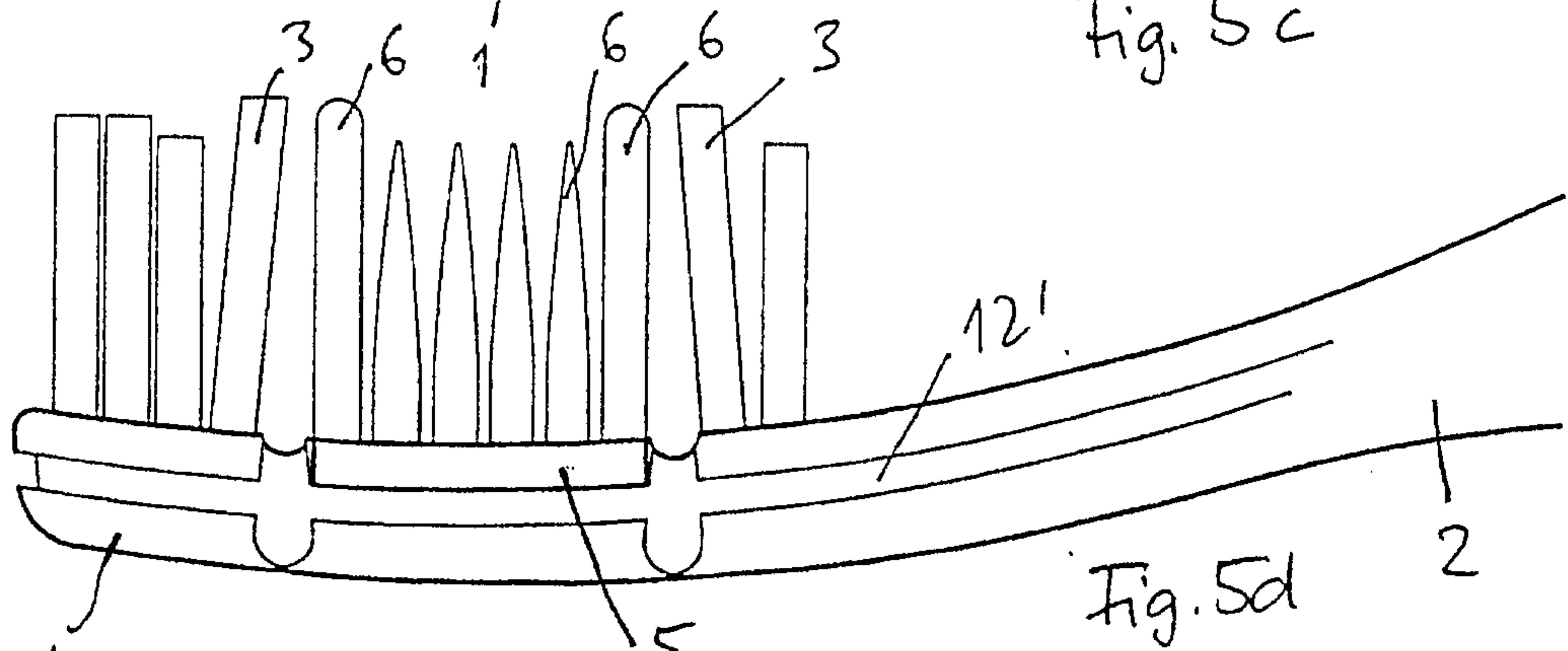
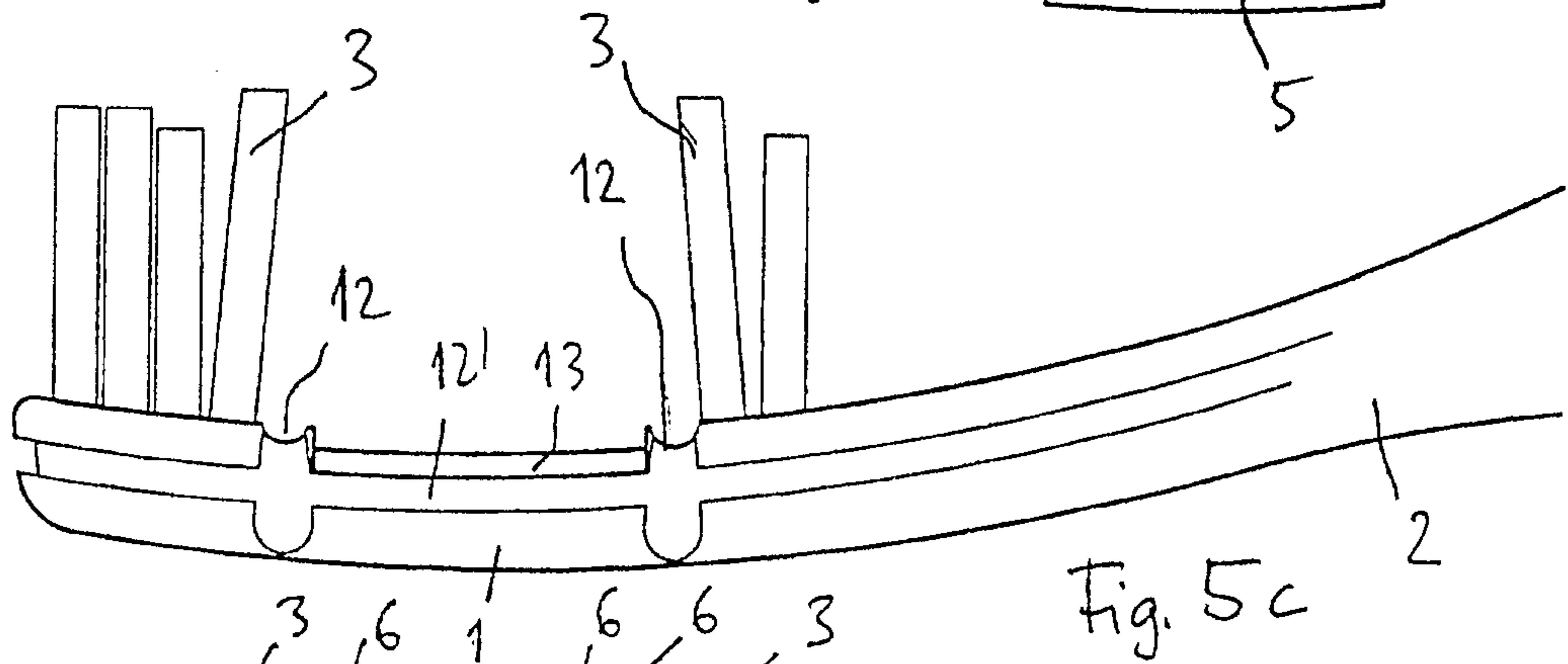
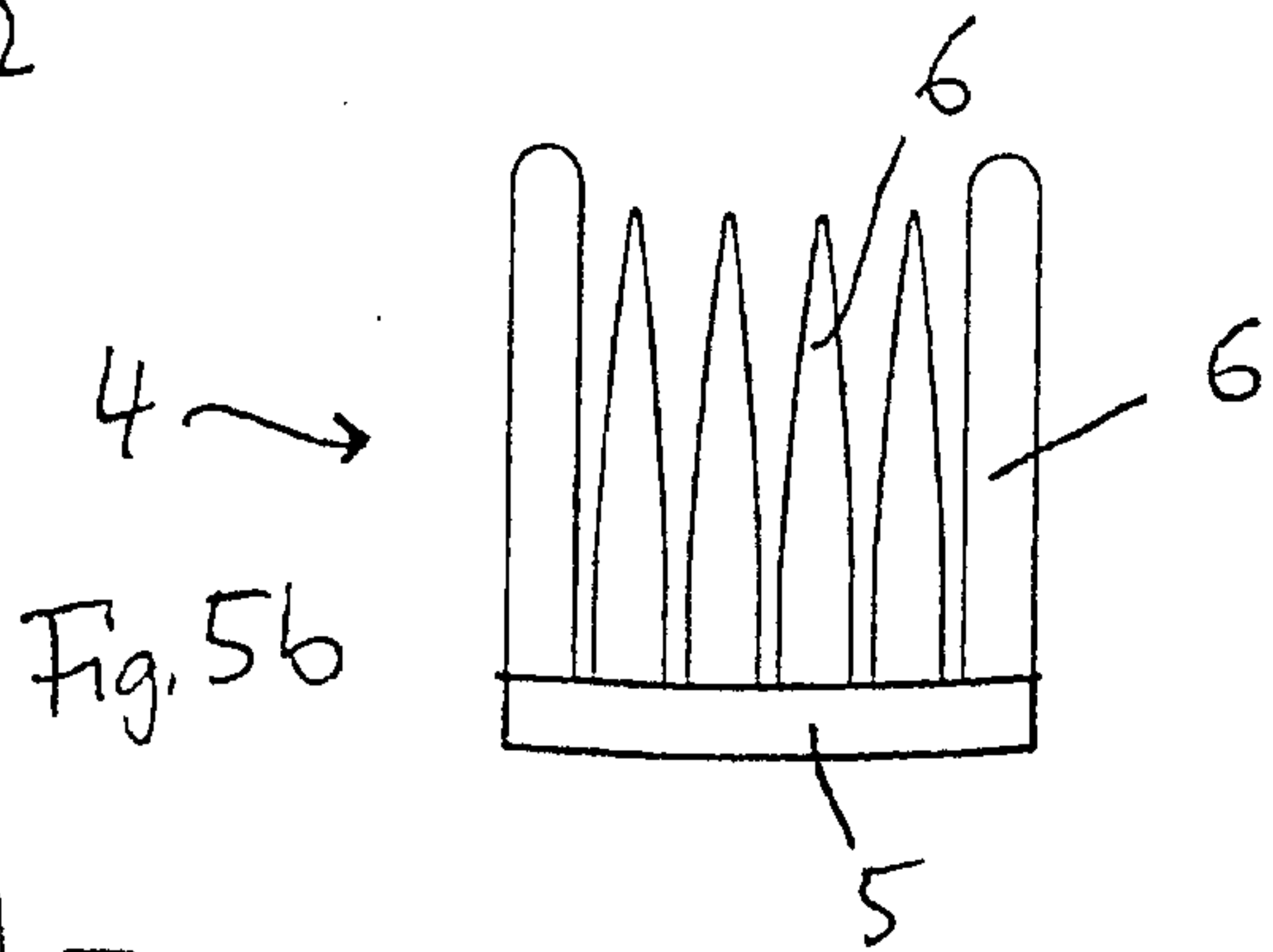
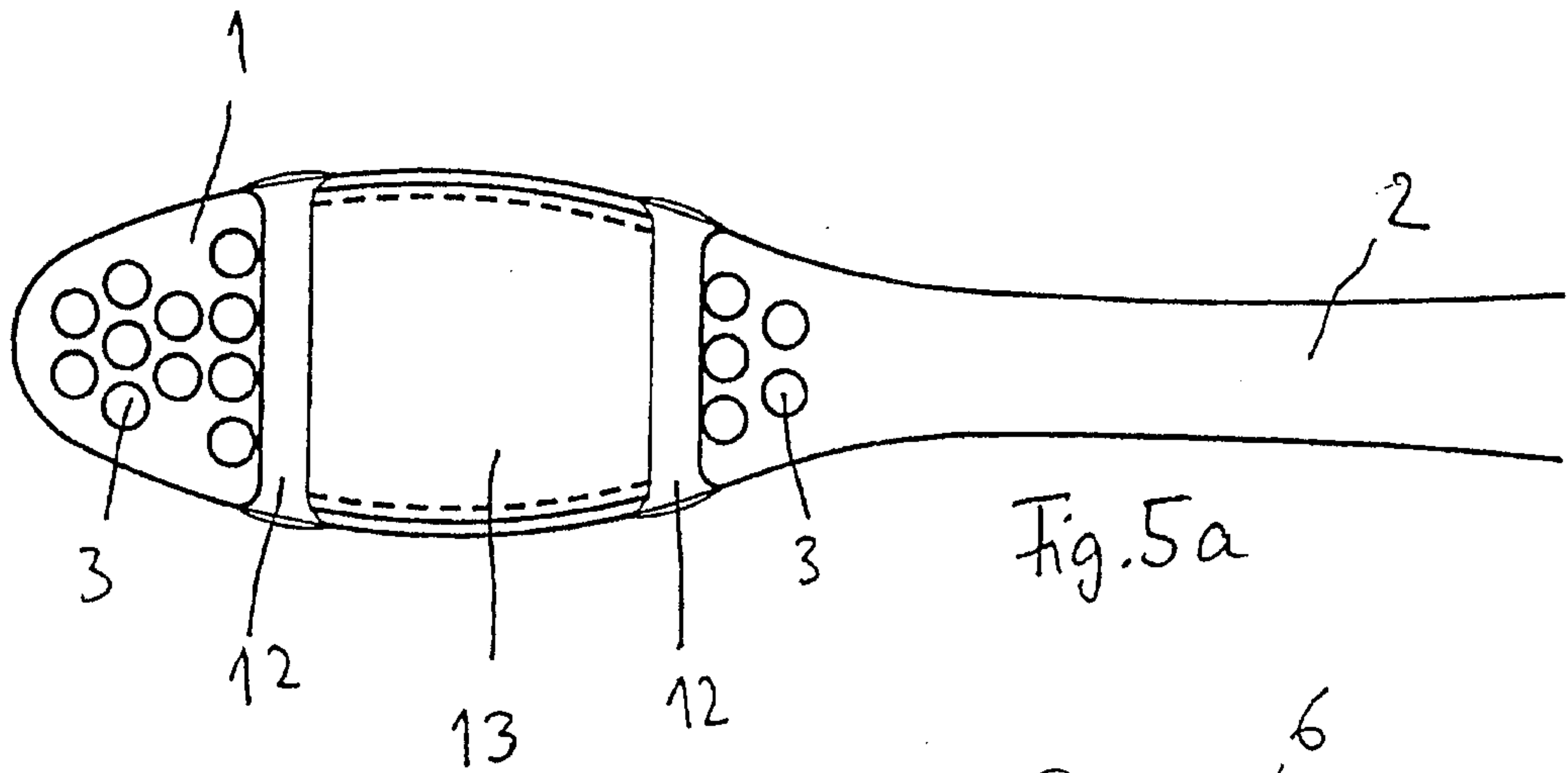

Fig. 3e





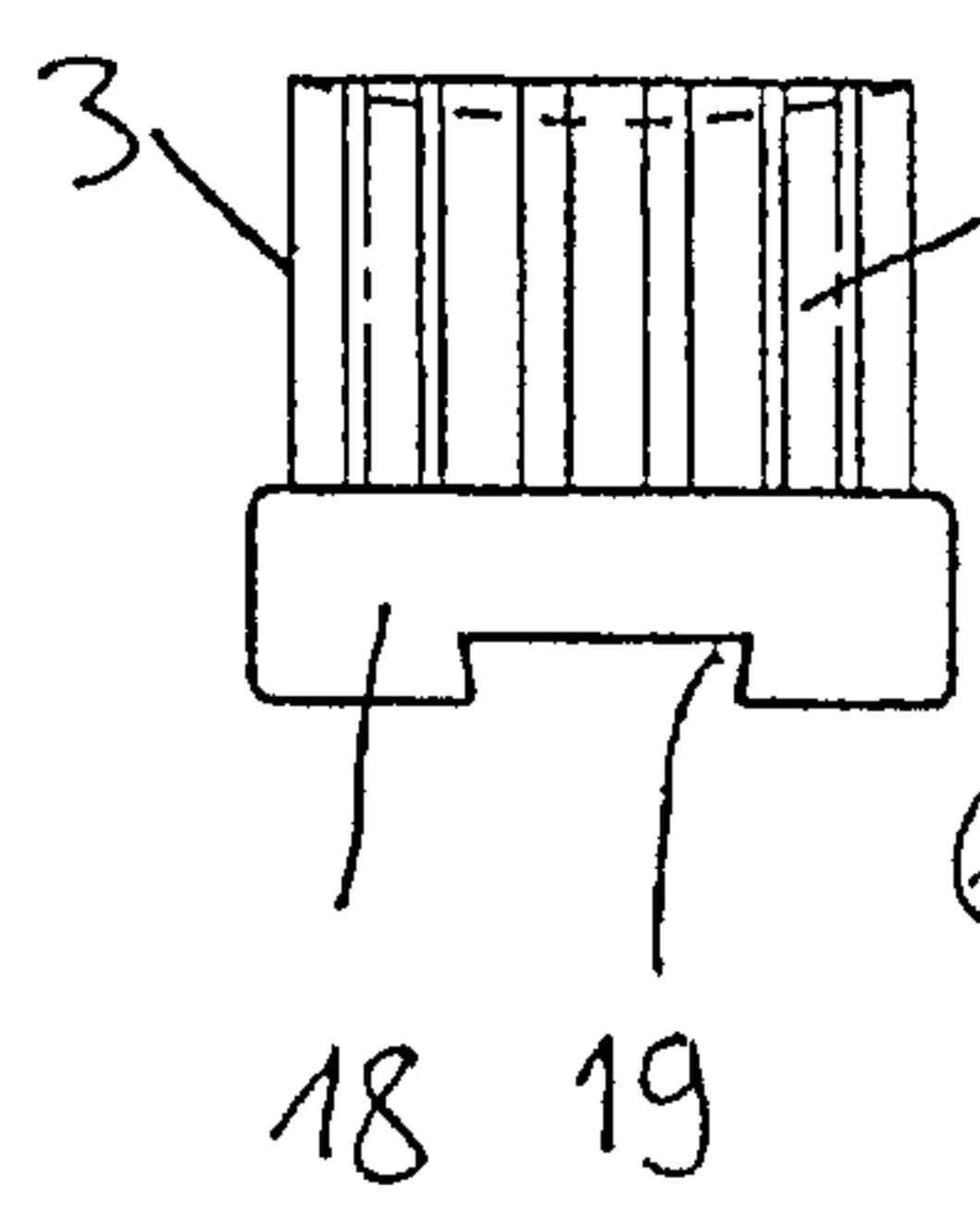
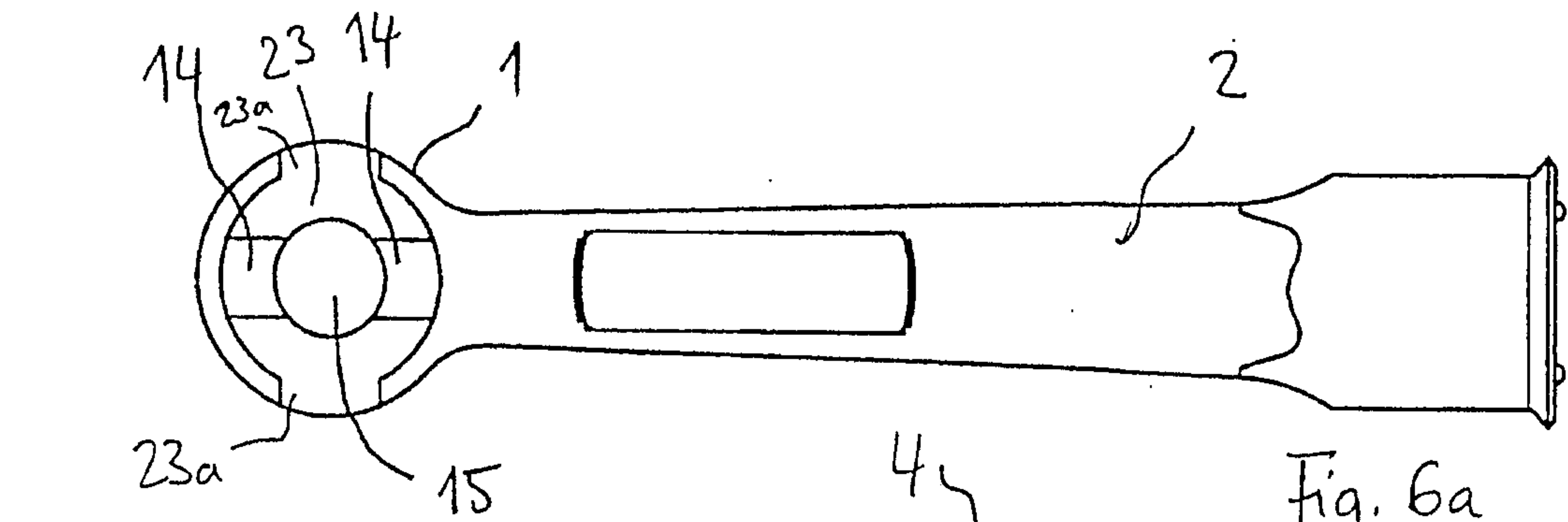

Fig. 6c

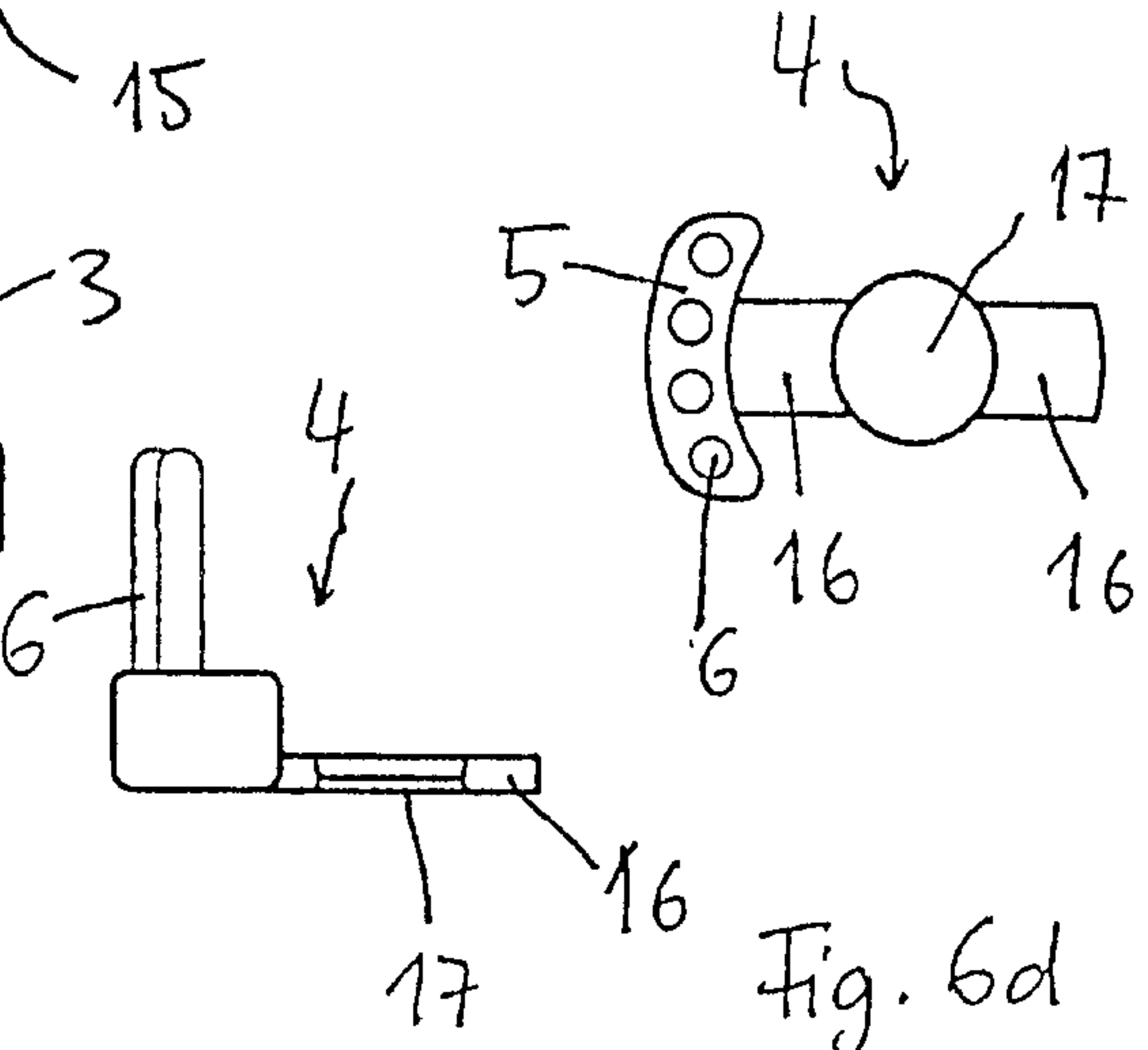

Fig. 6b

Fig. 6d

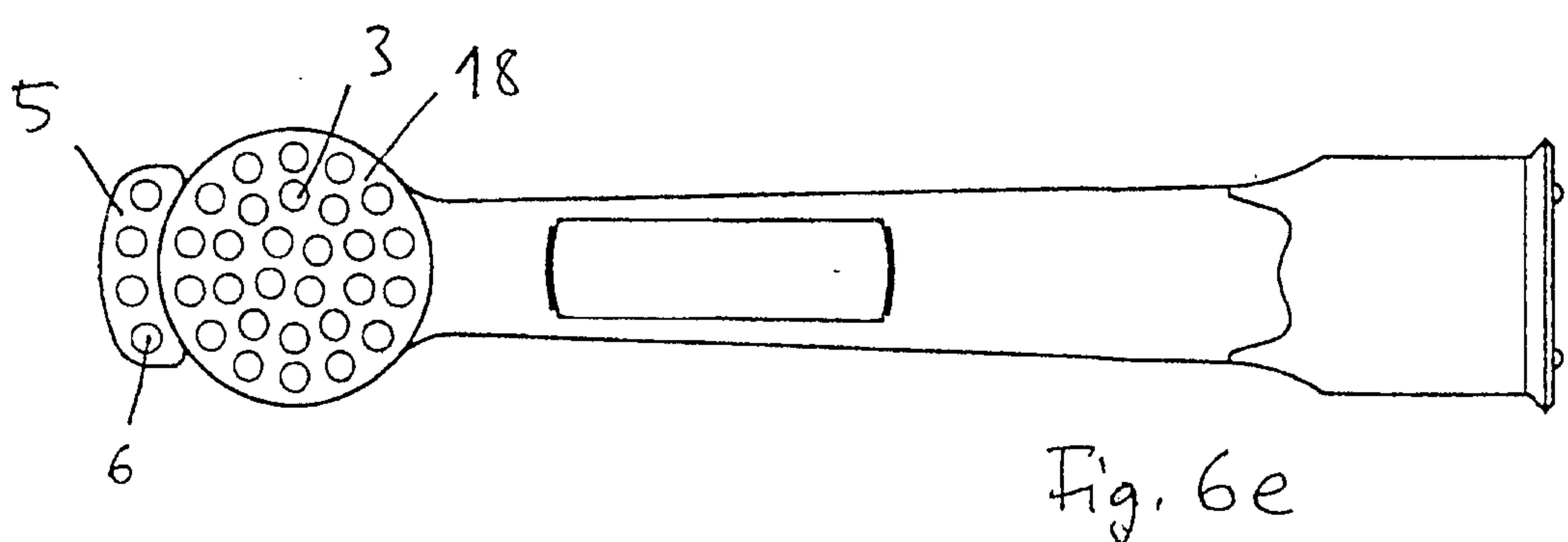

Fig. 6e

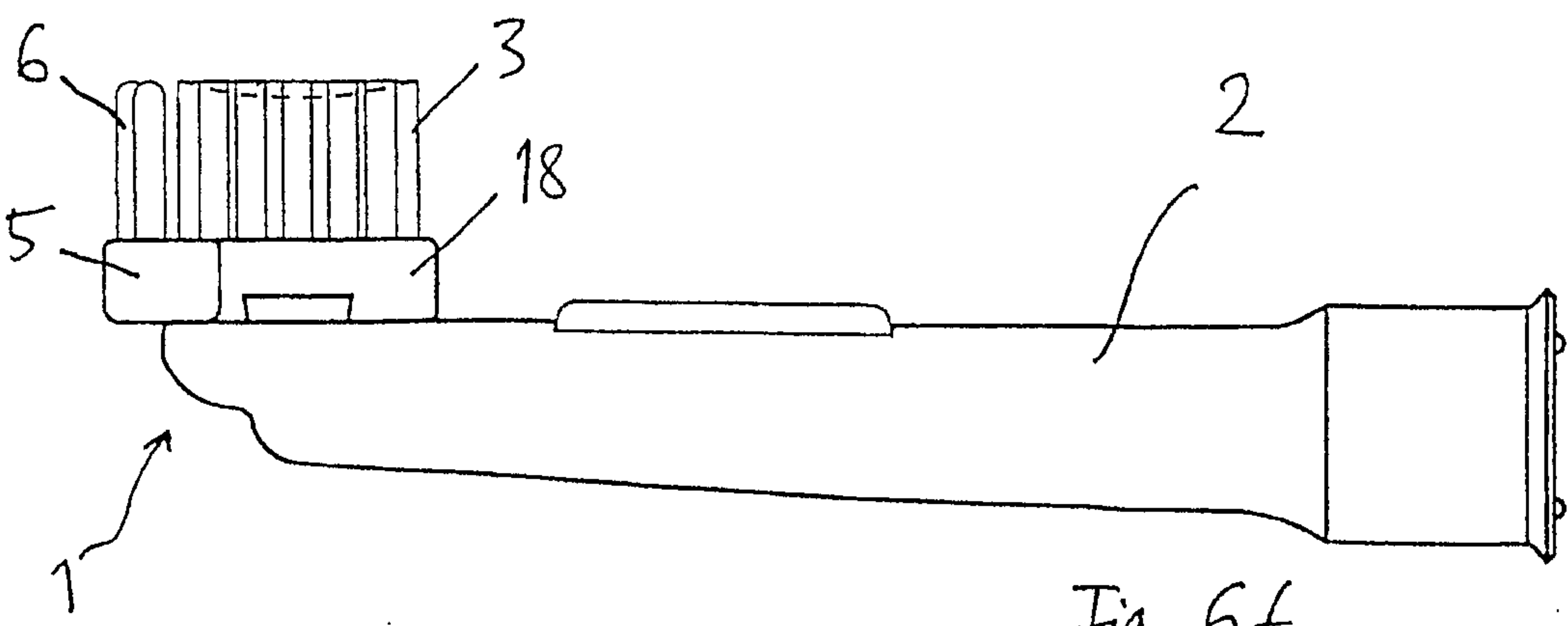
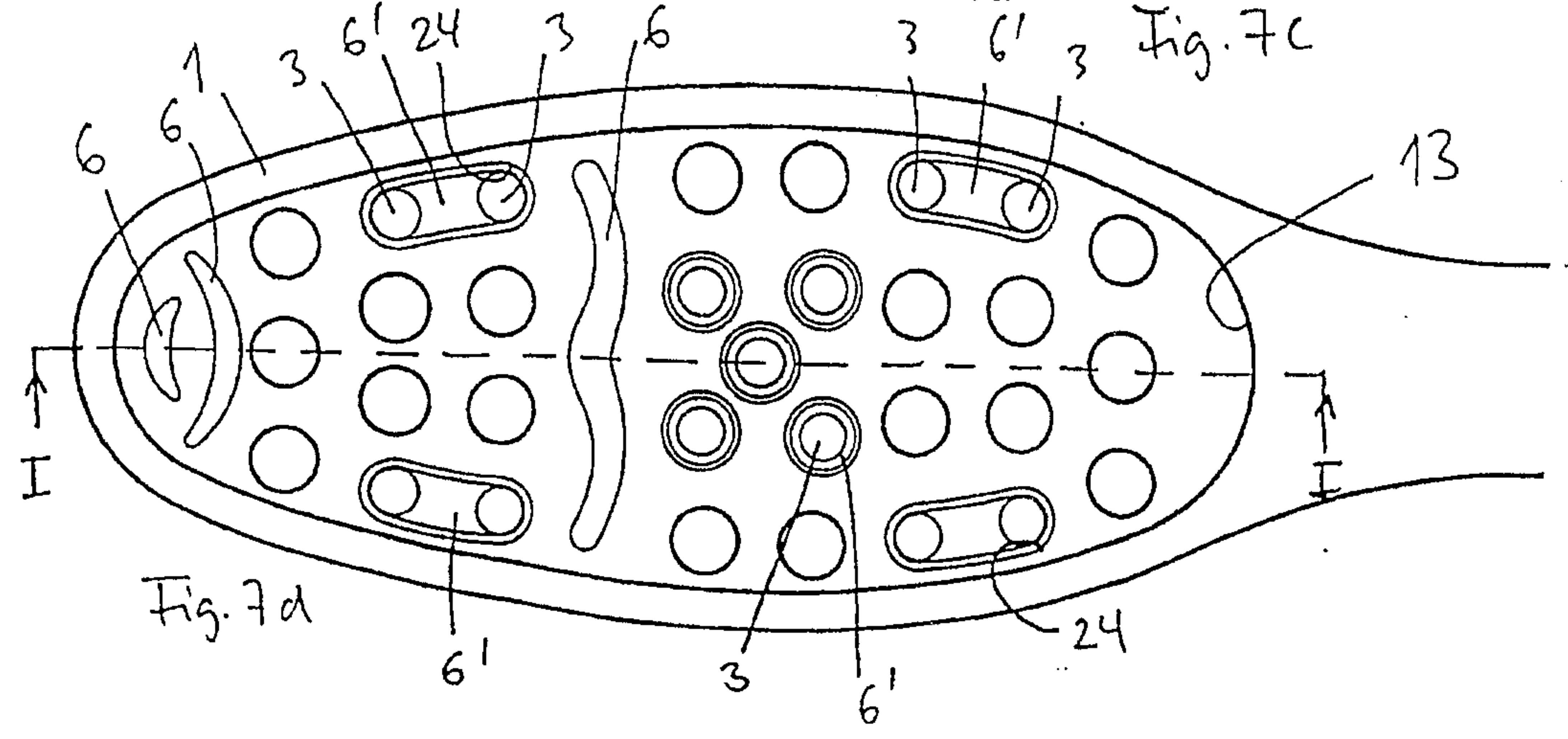
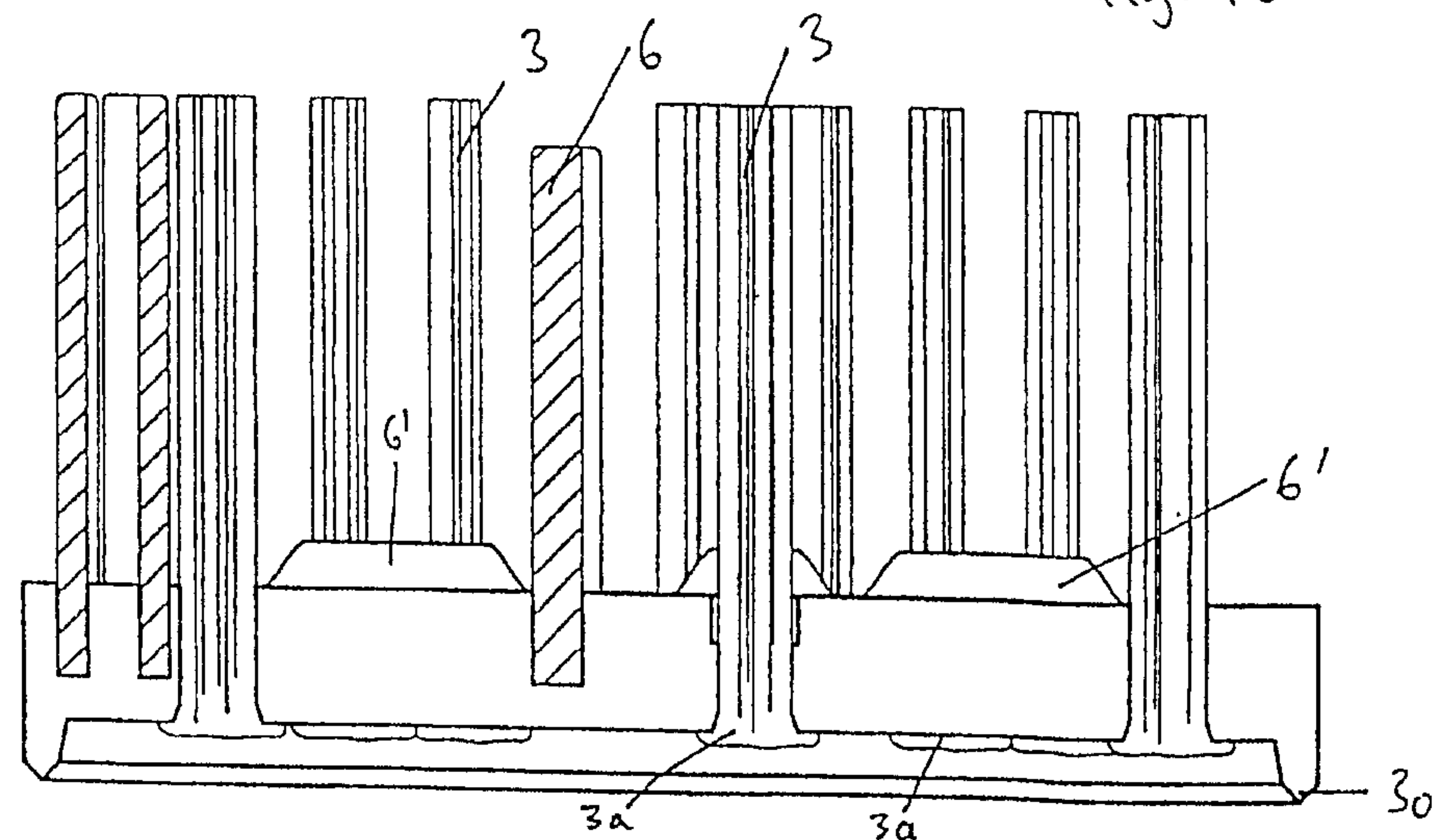
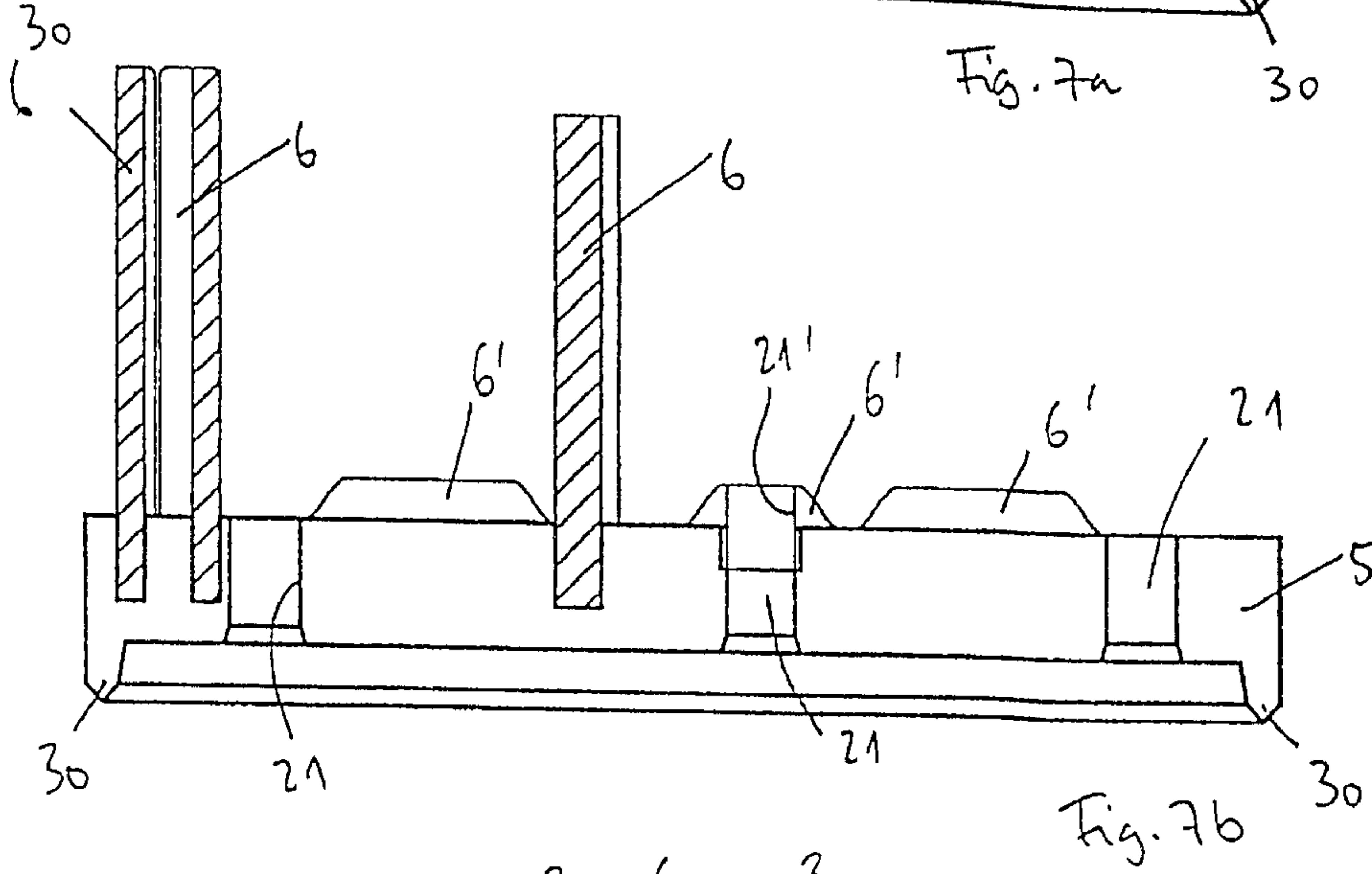
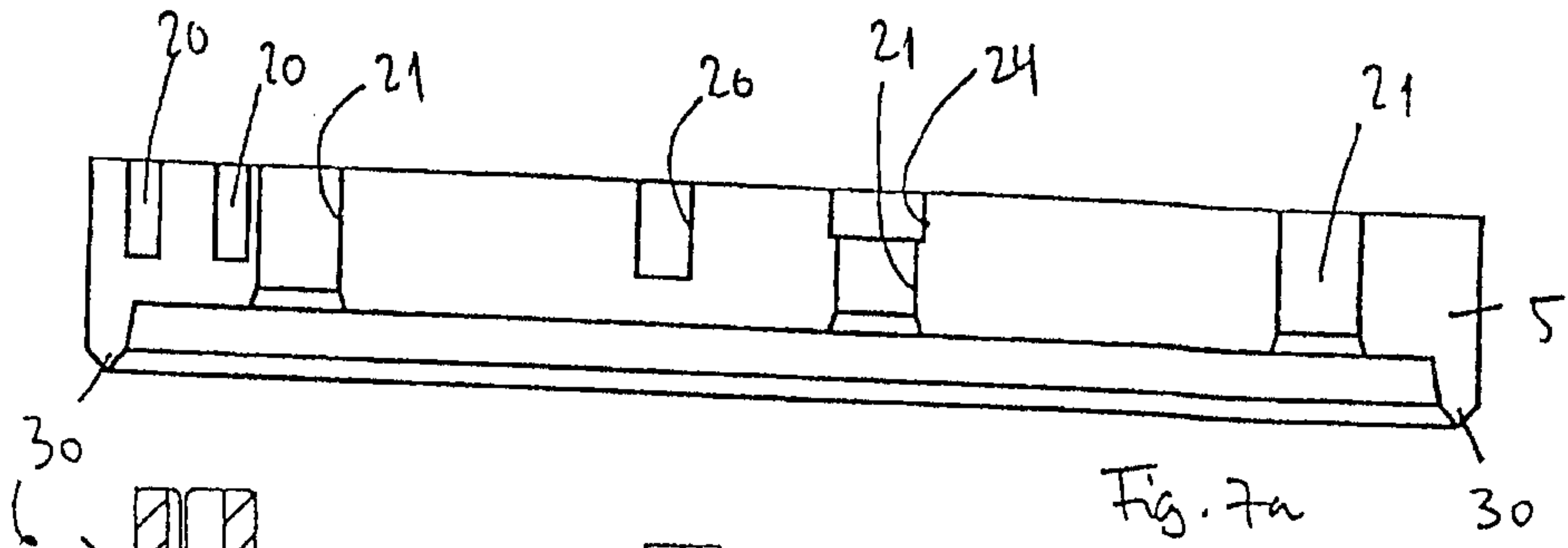
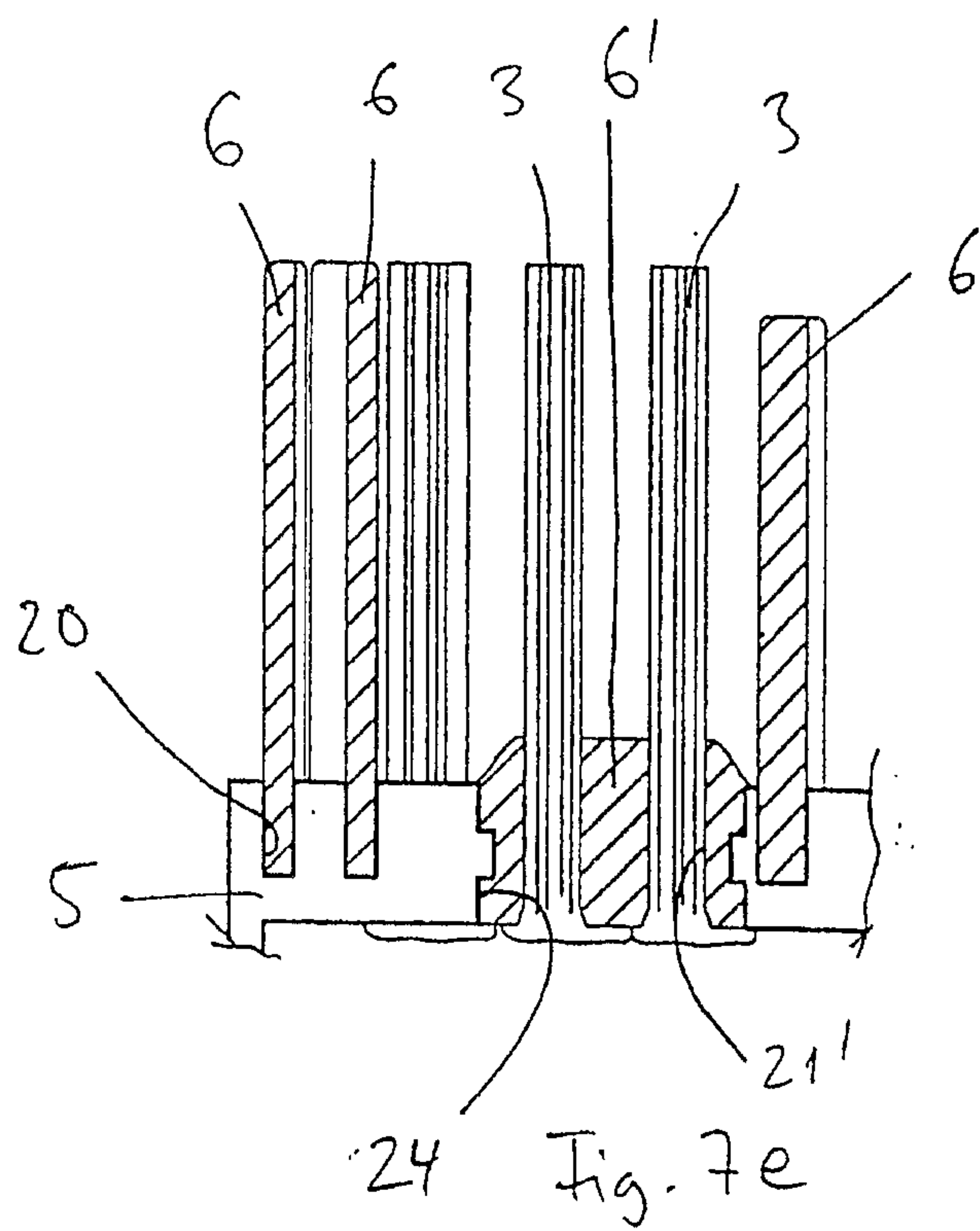
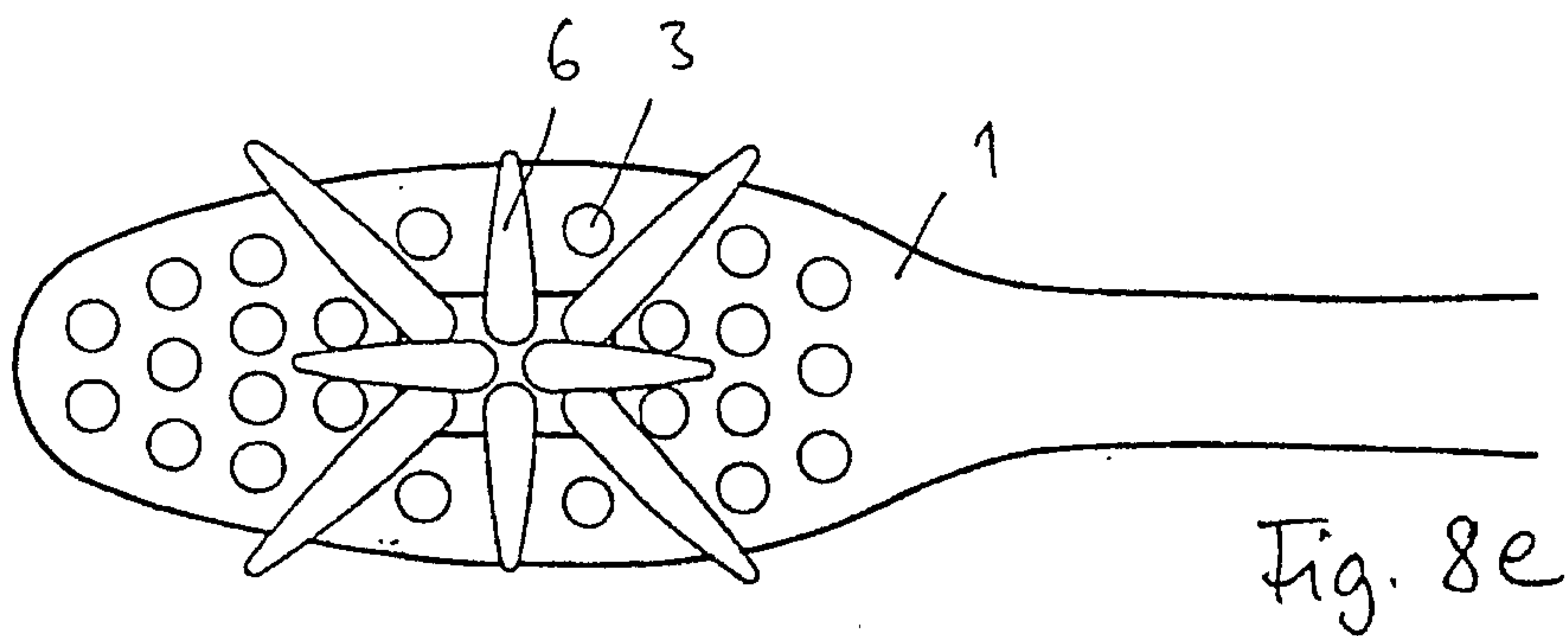
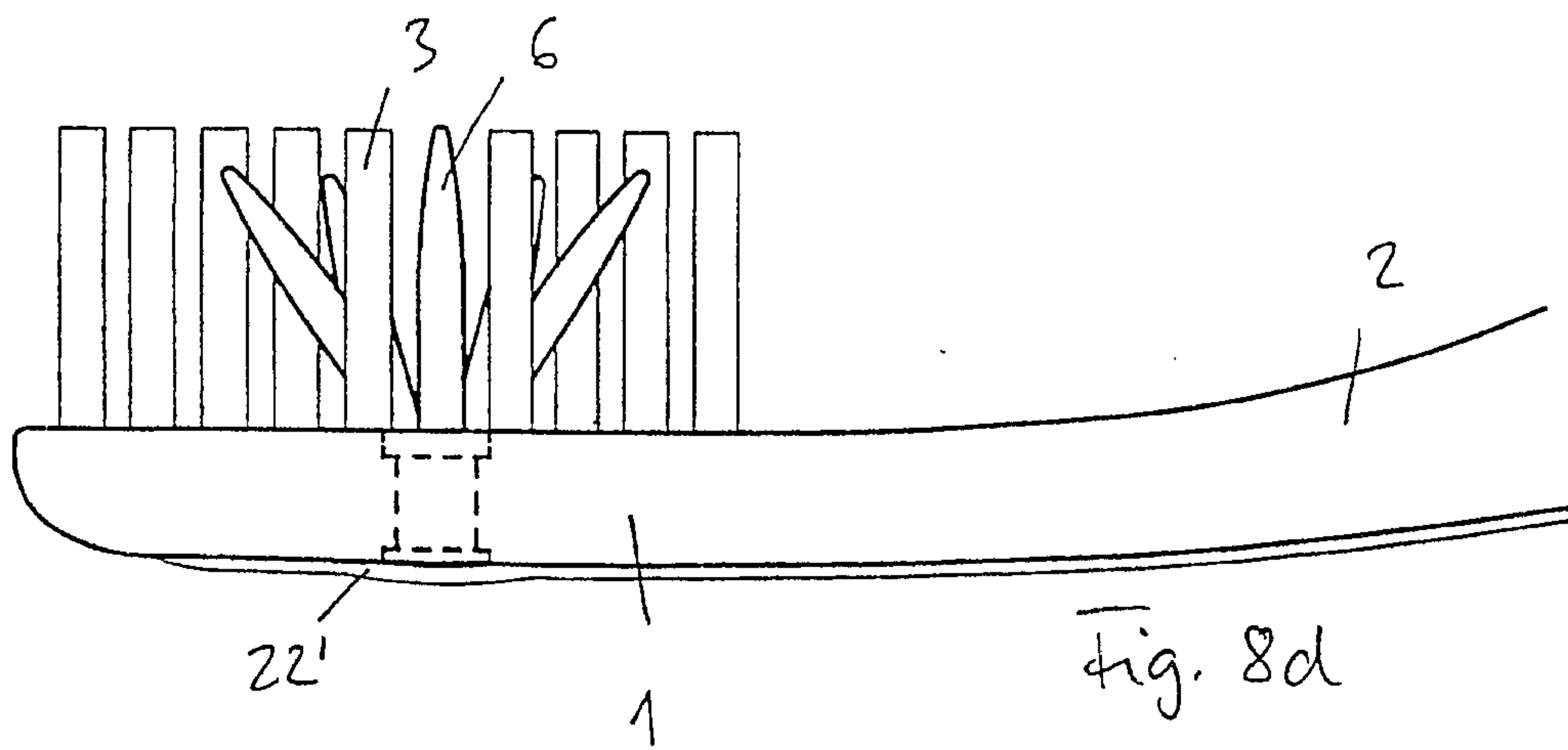
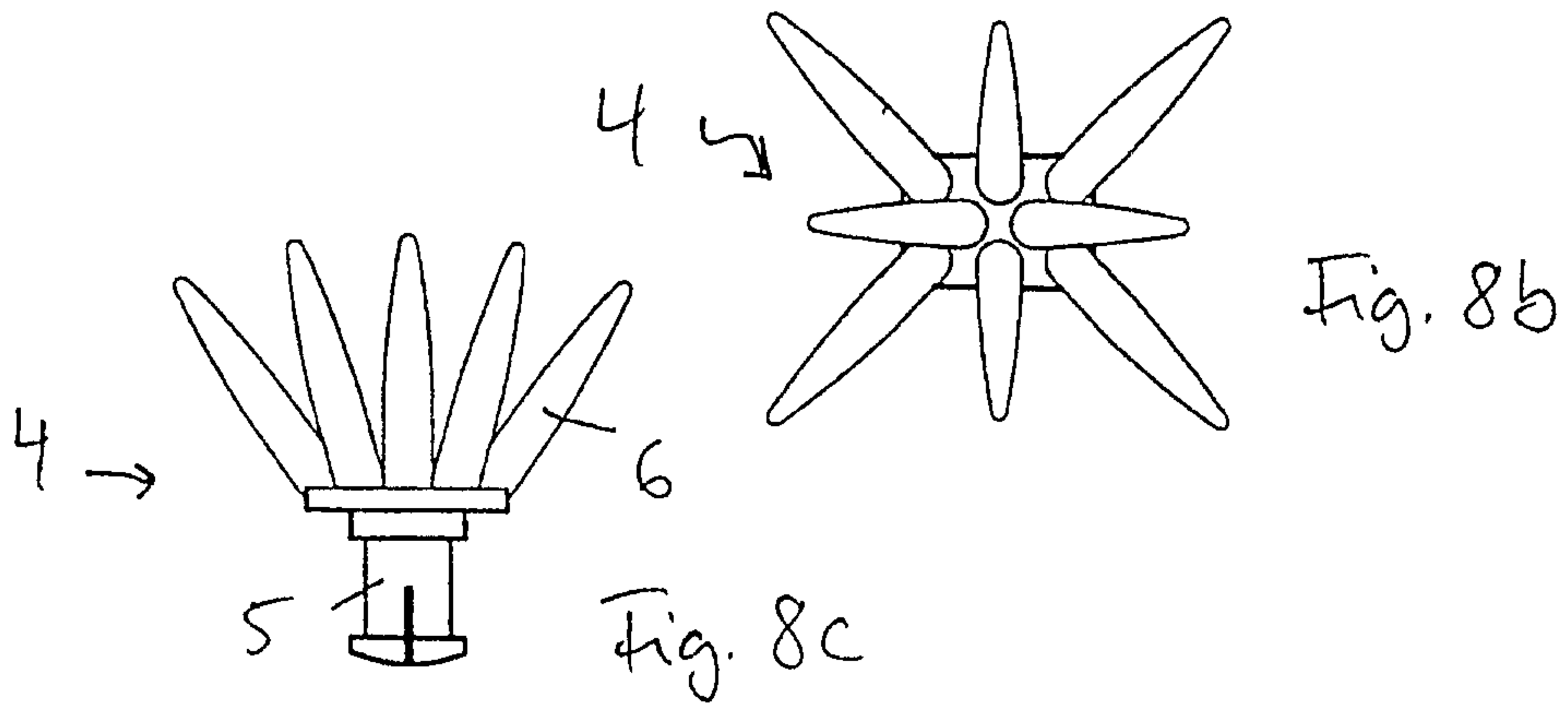
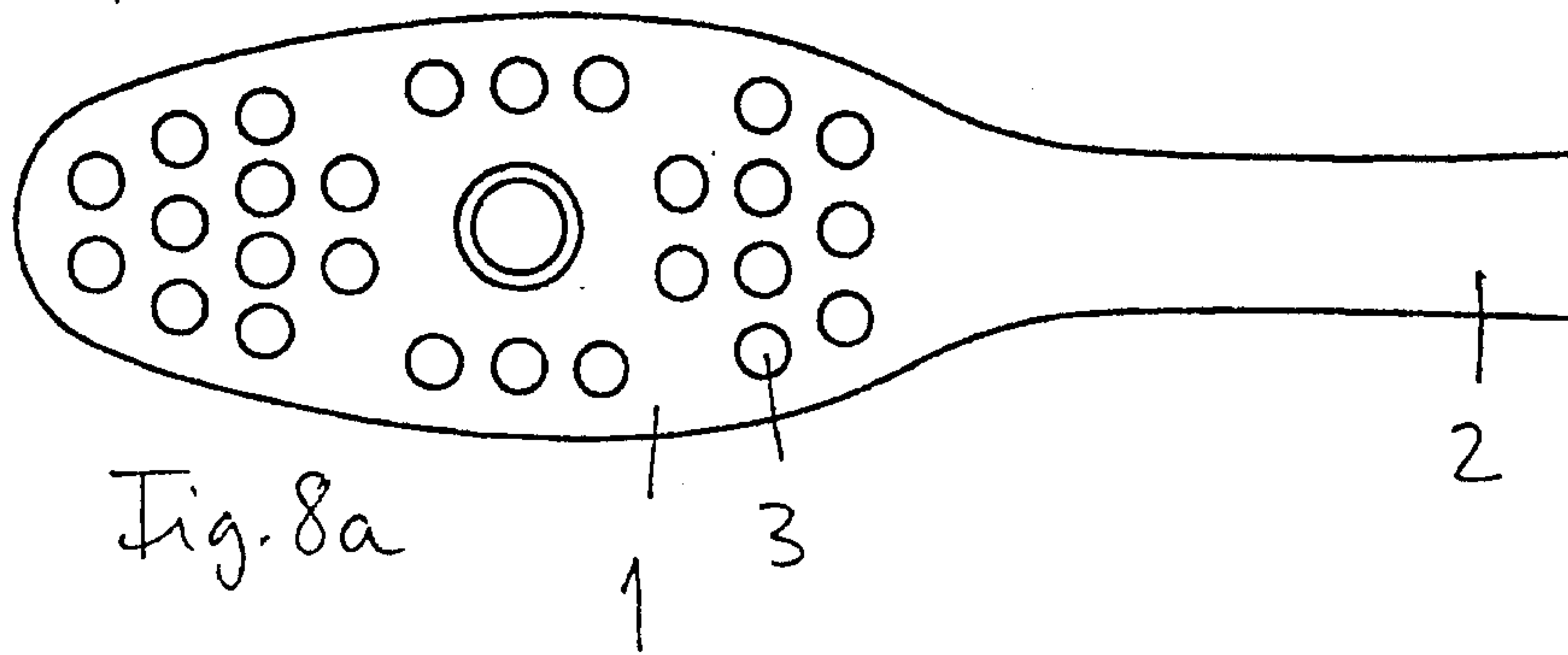

Fig. 6f







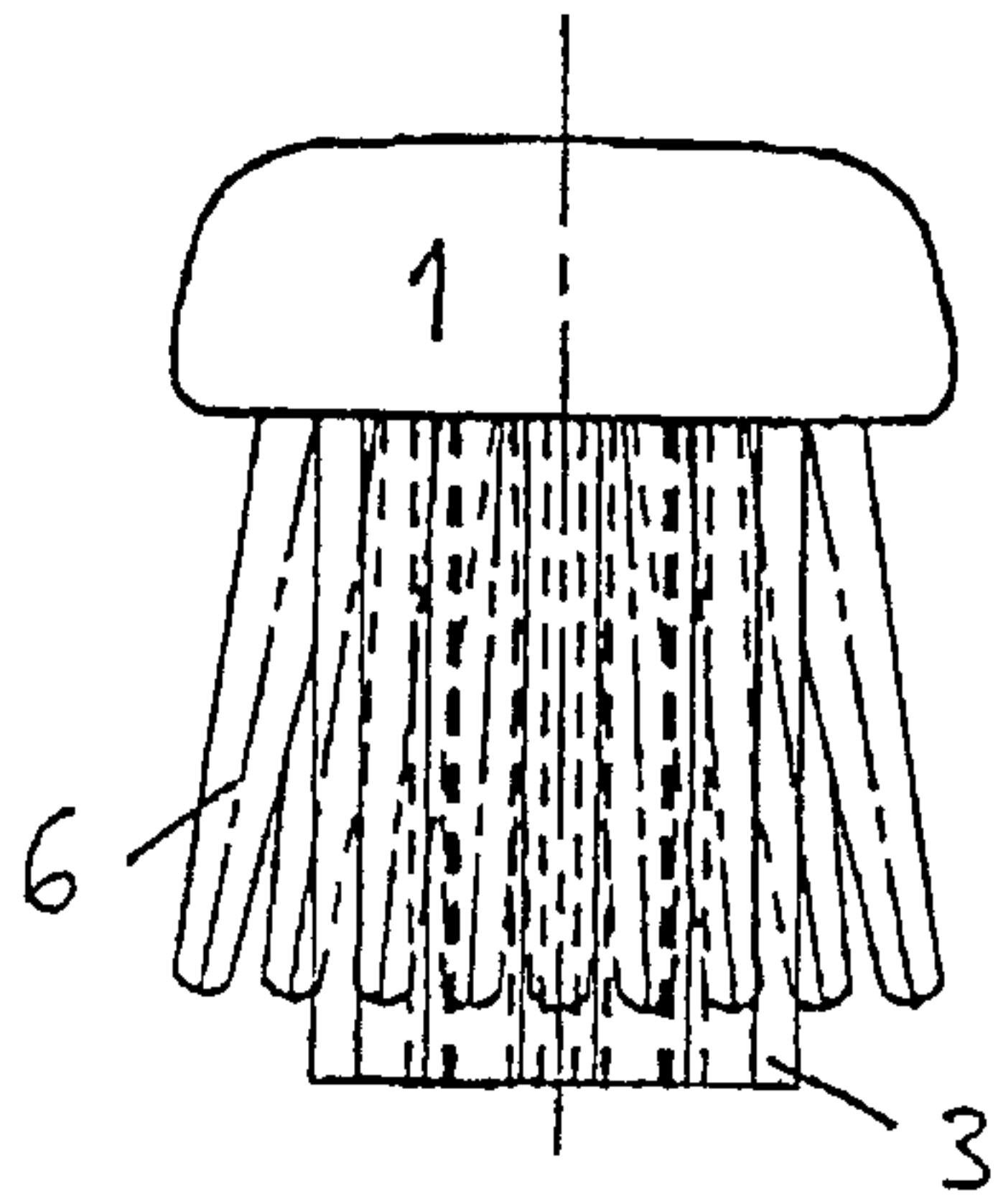

Fig. 9a

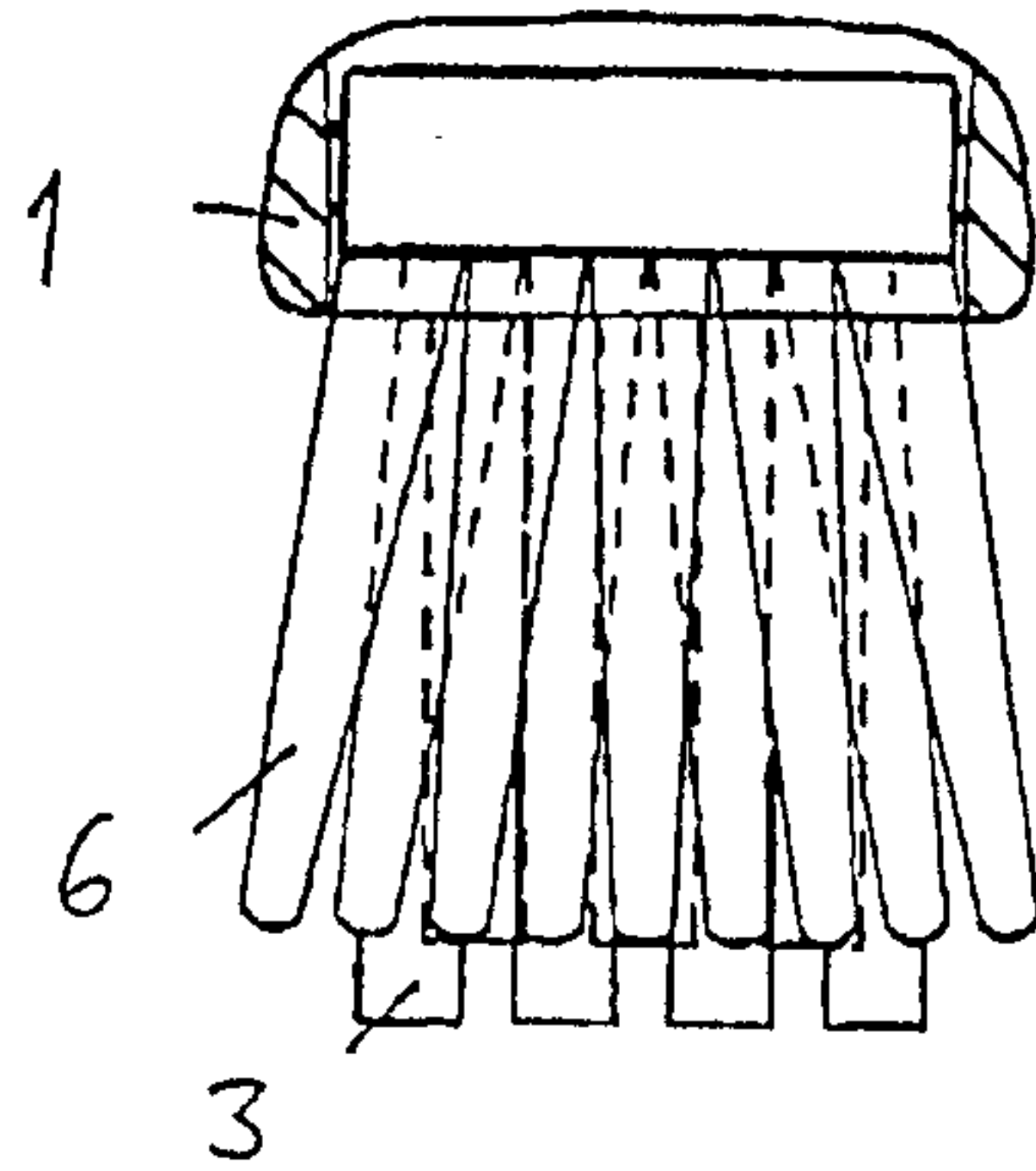

Fig. 9b

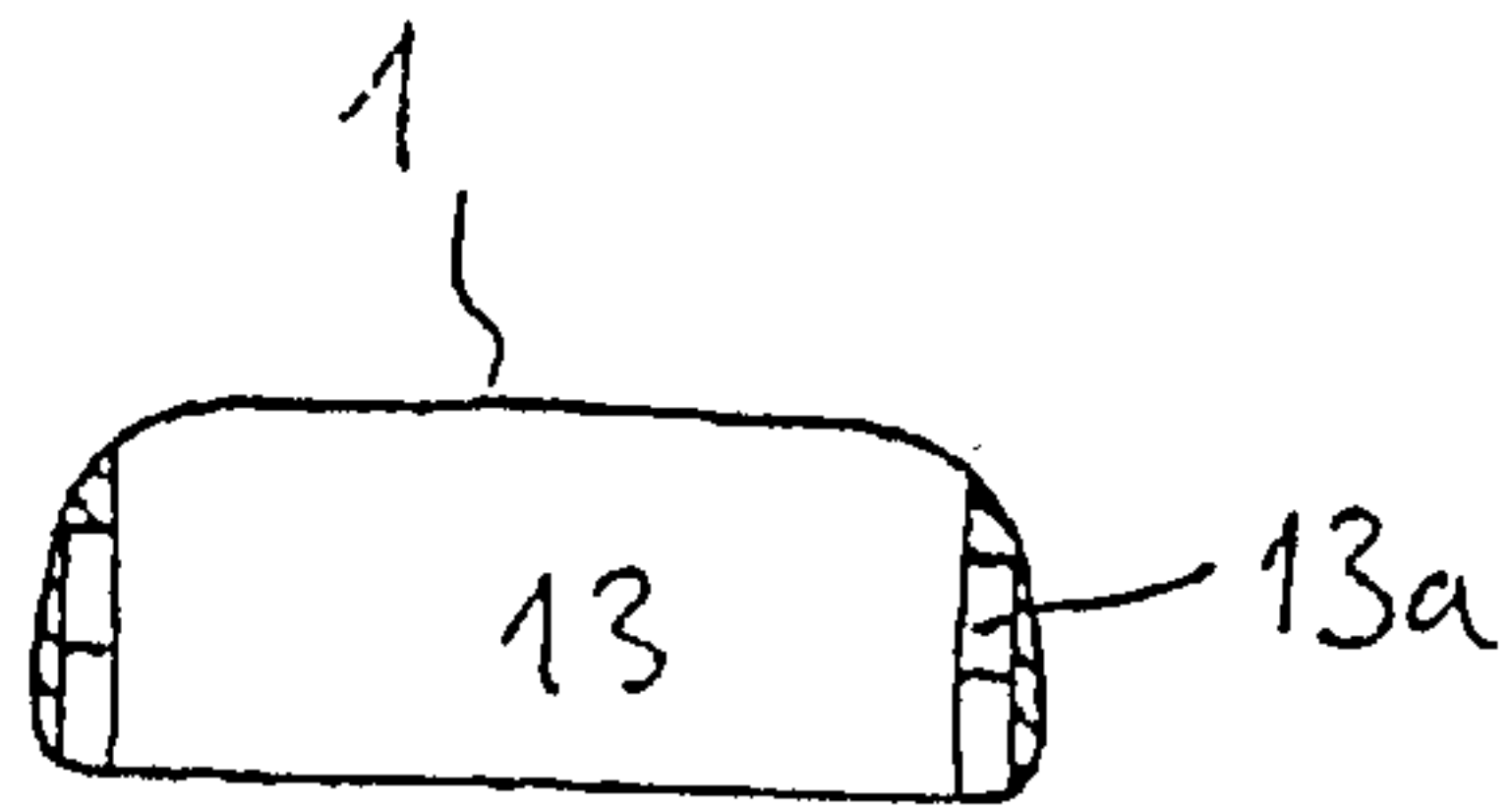

Fig. 9c

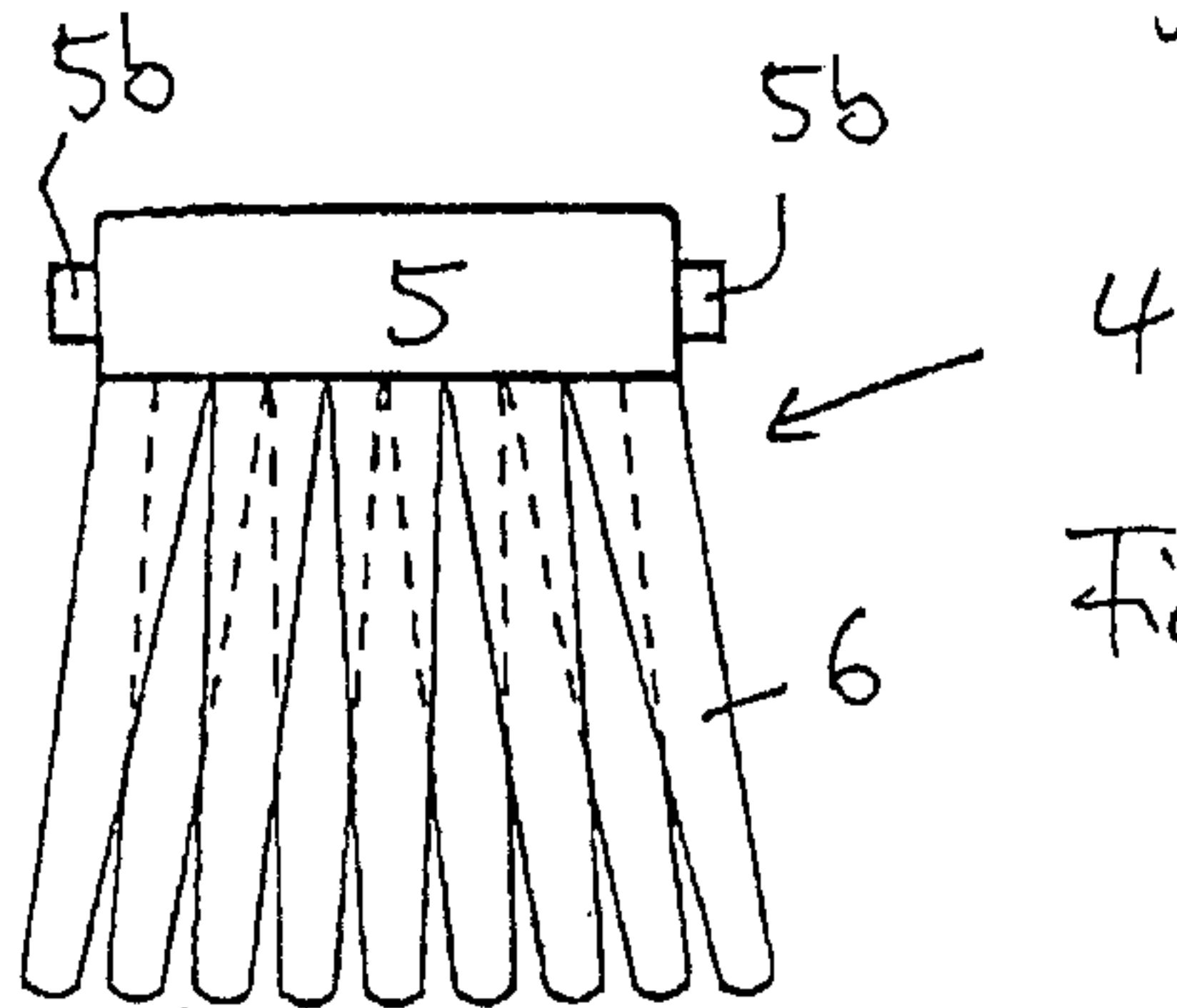

Fig. 9d

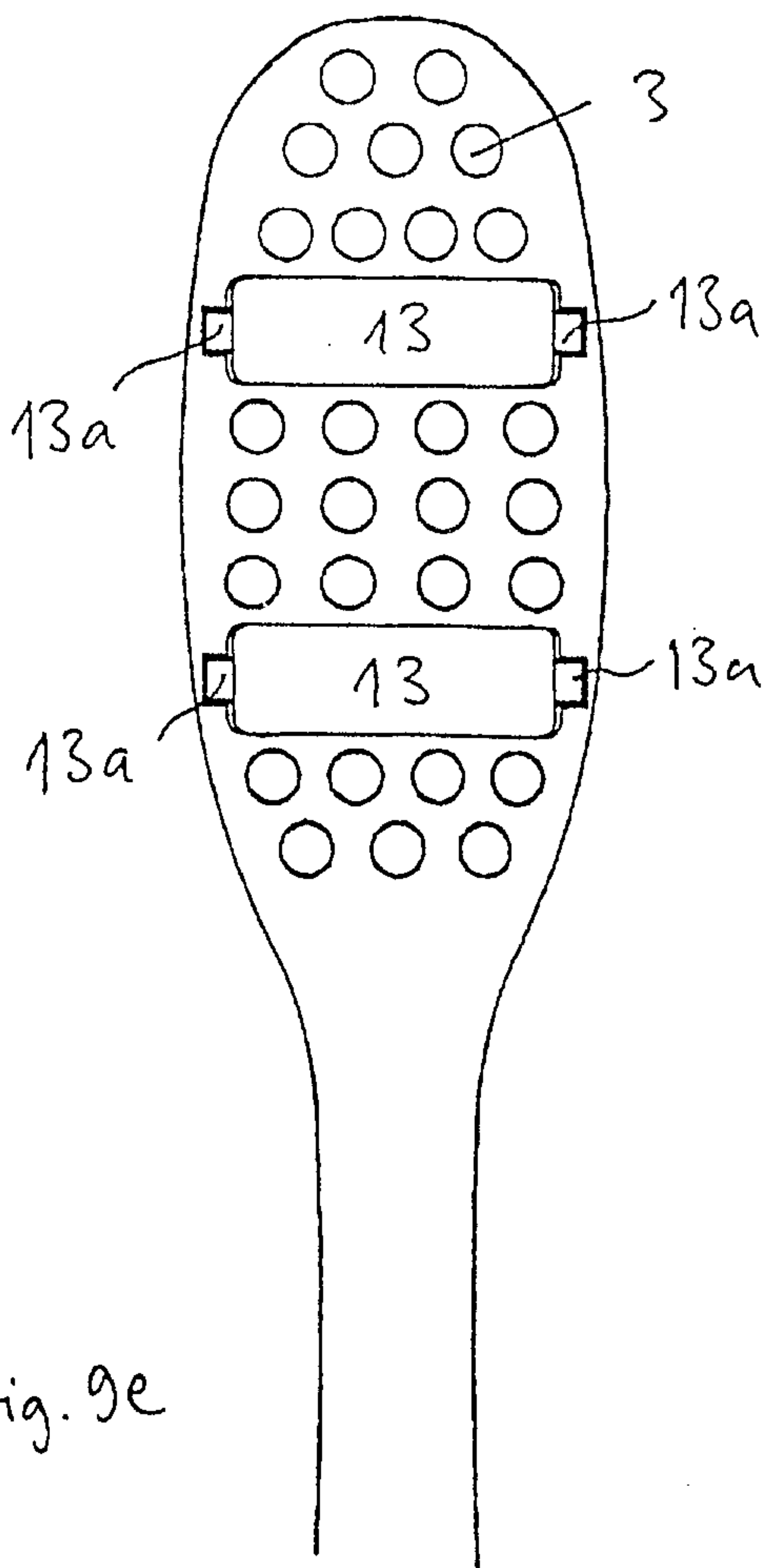

Fig. 9e

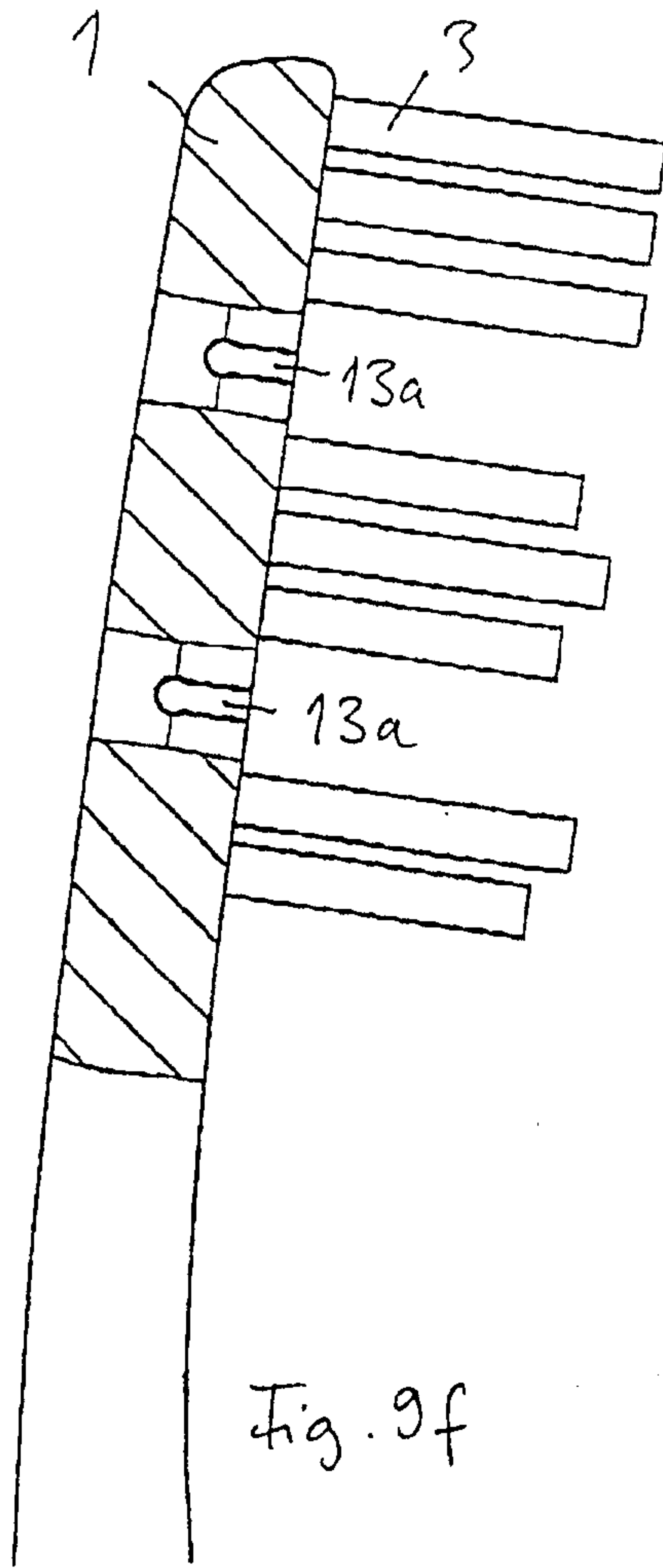
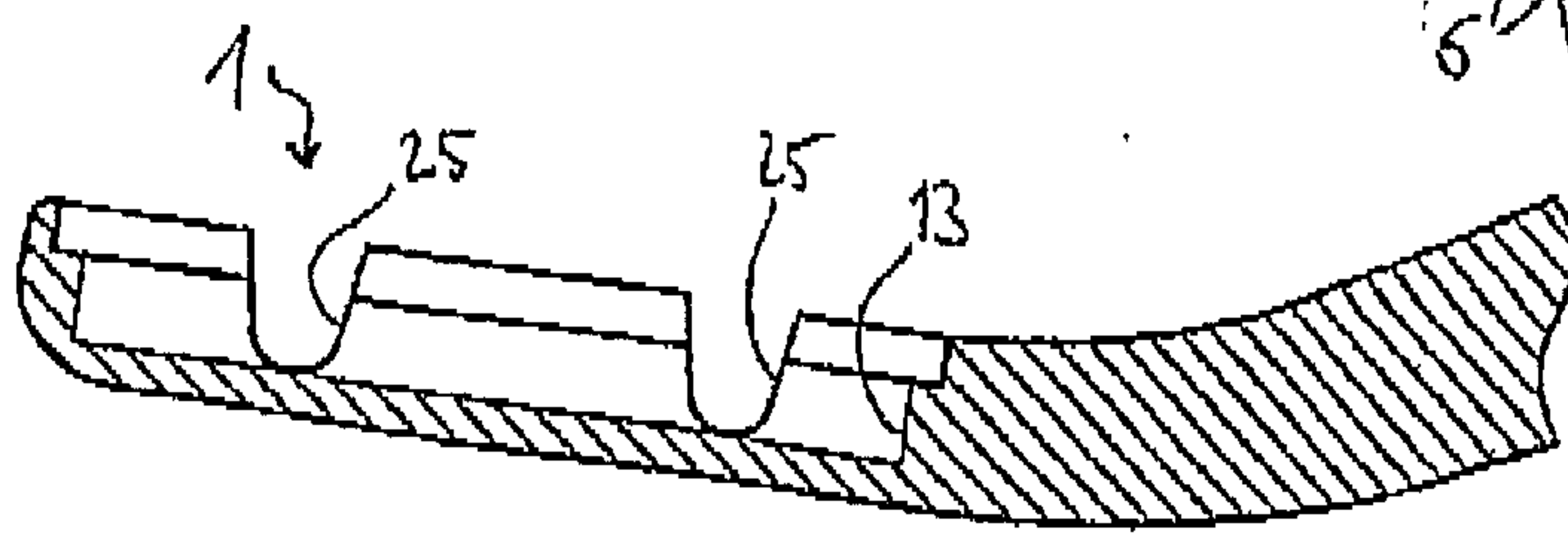
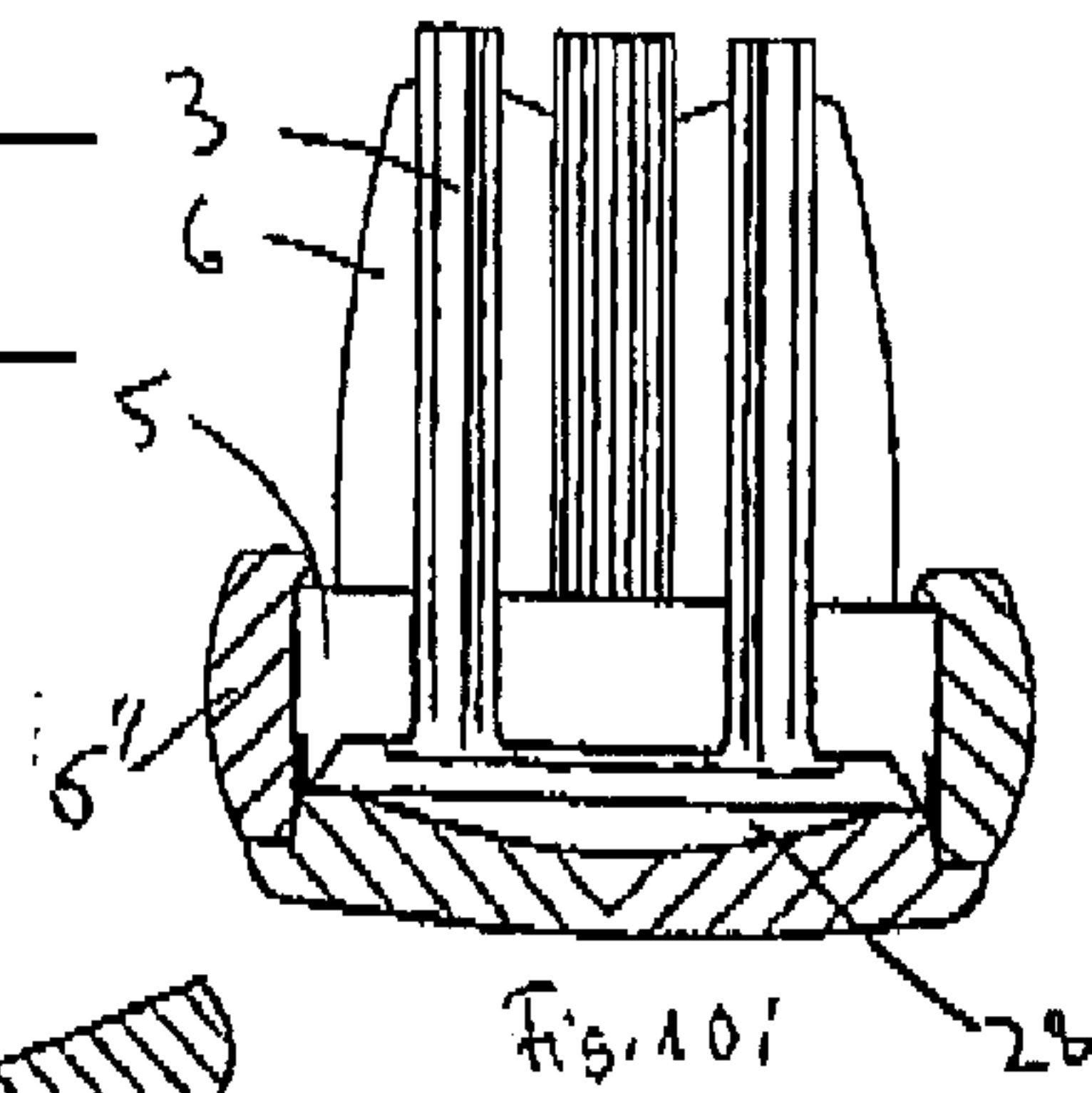
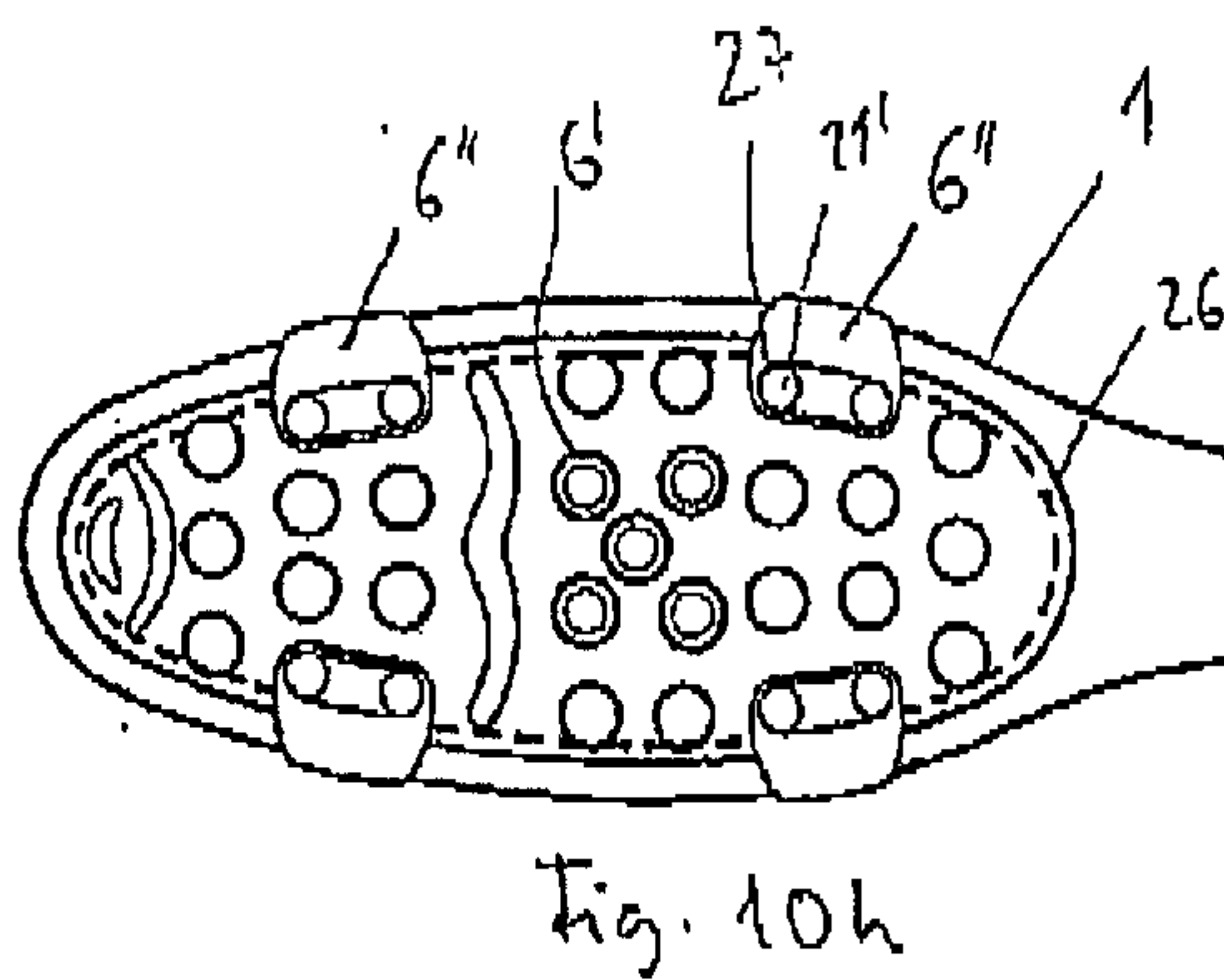
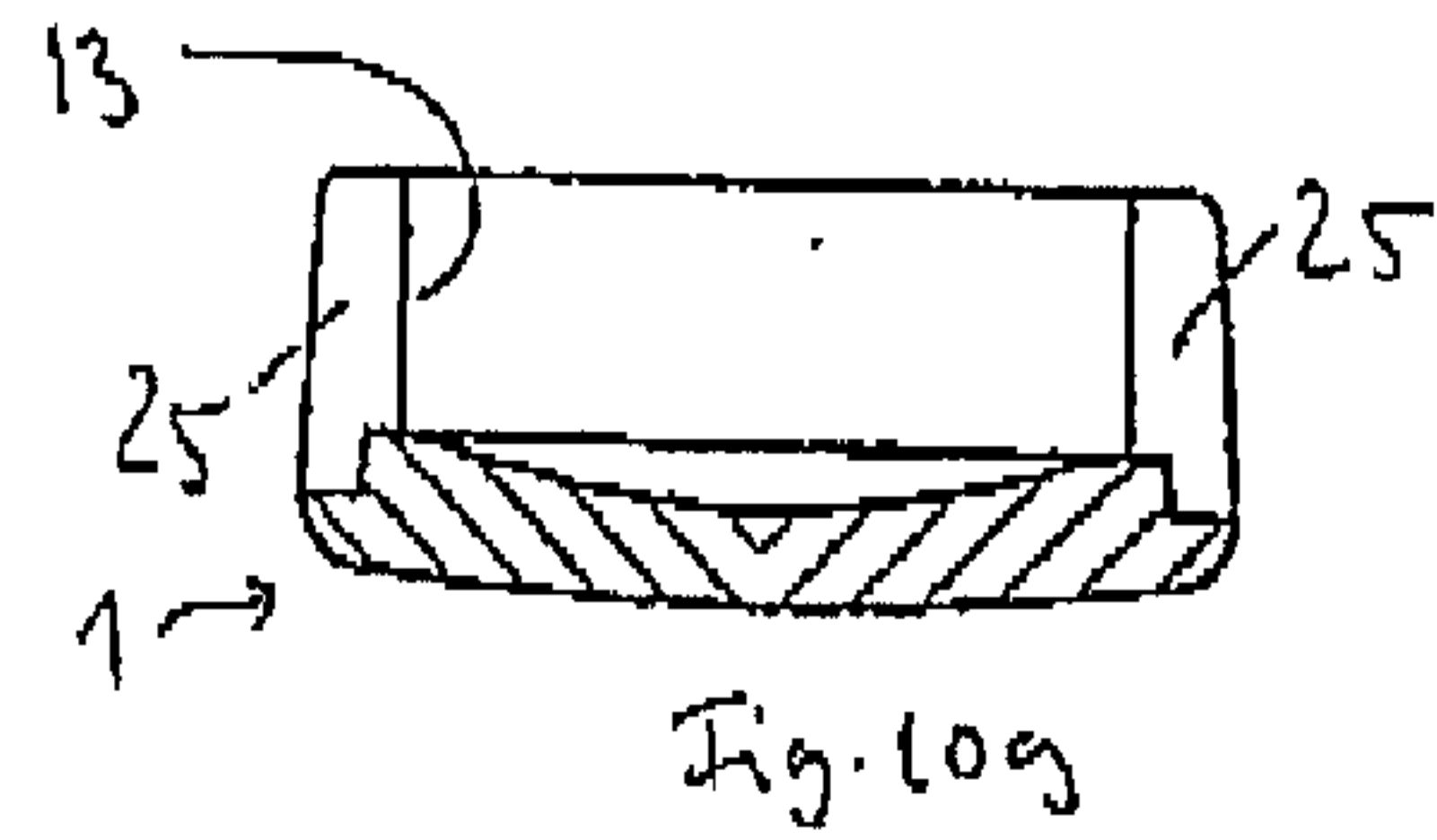
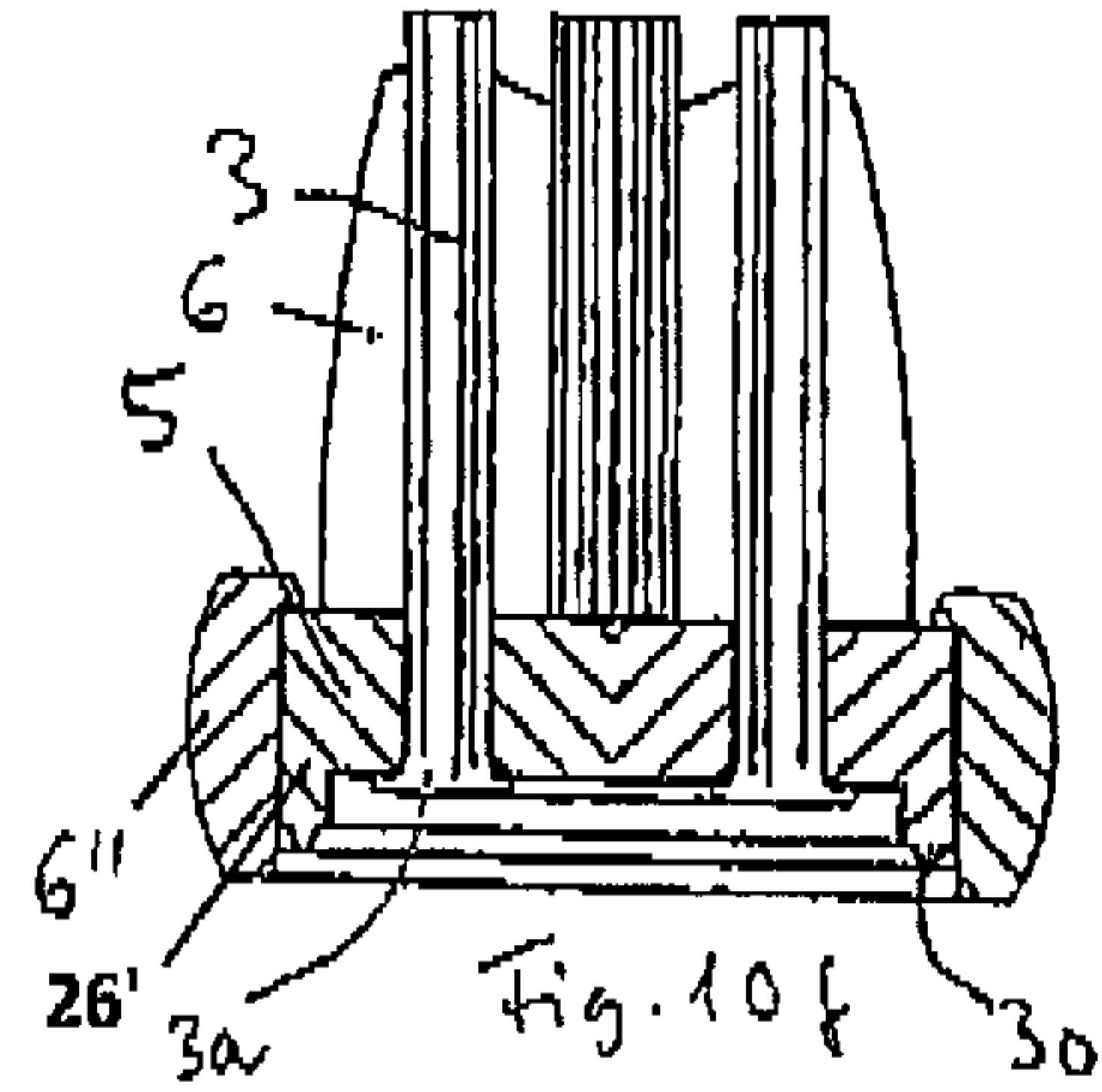
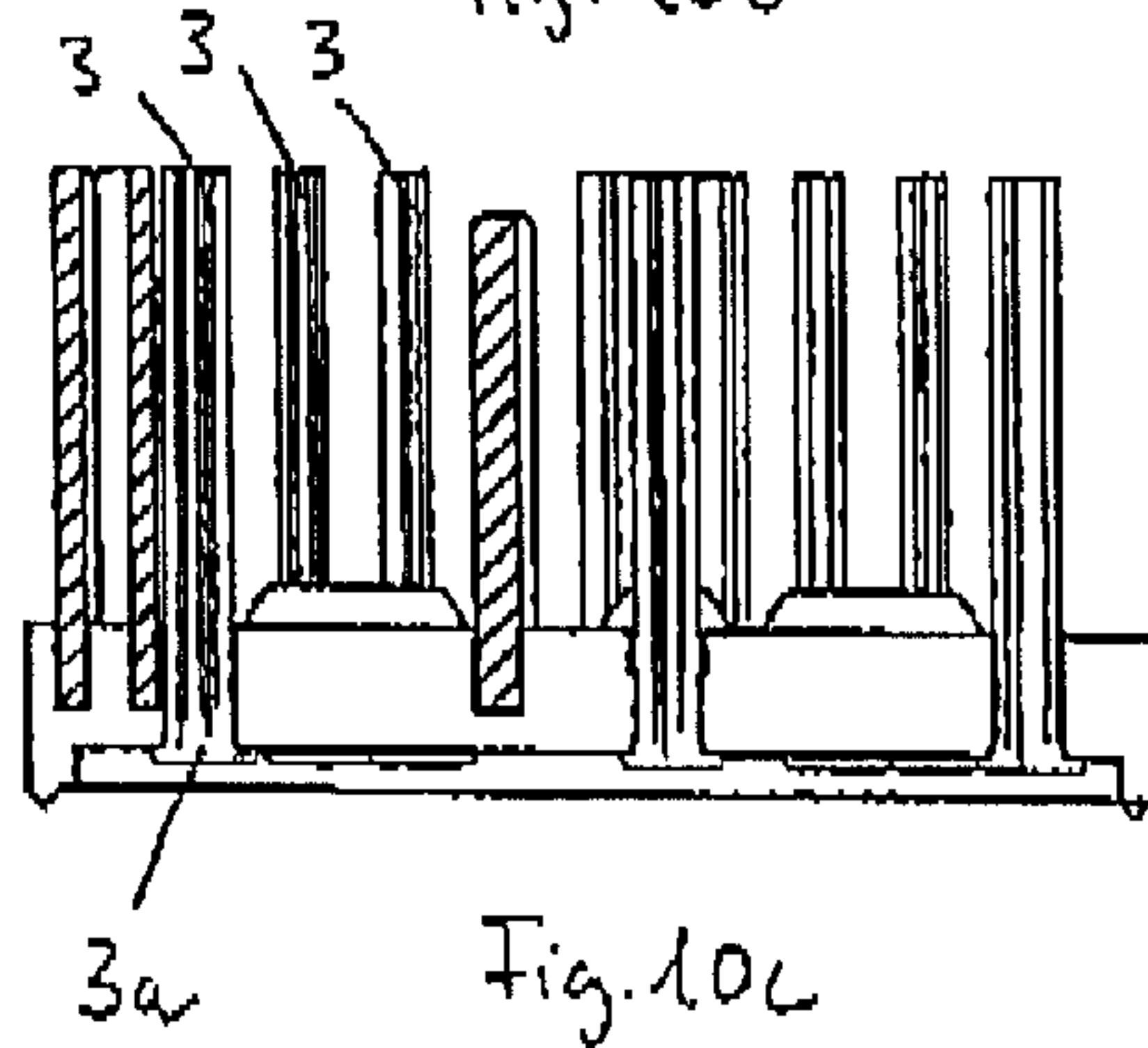
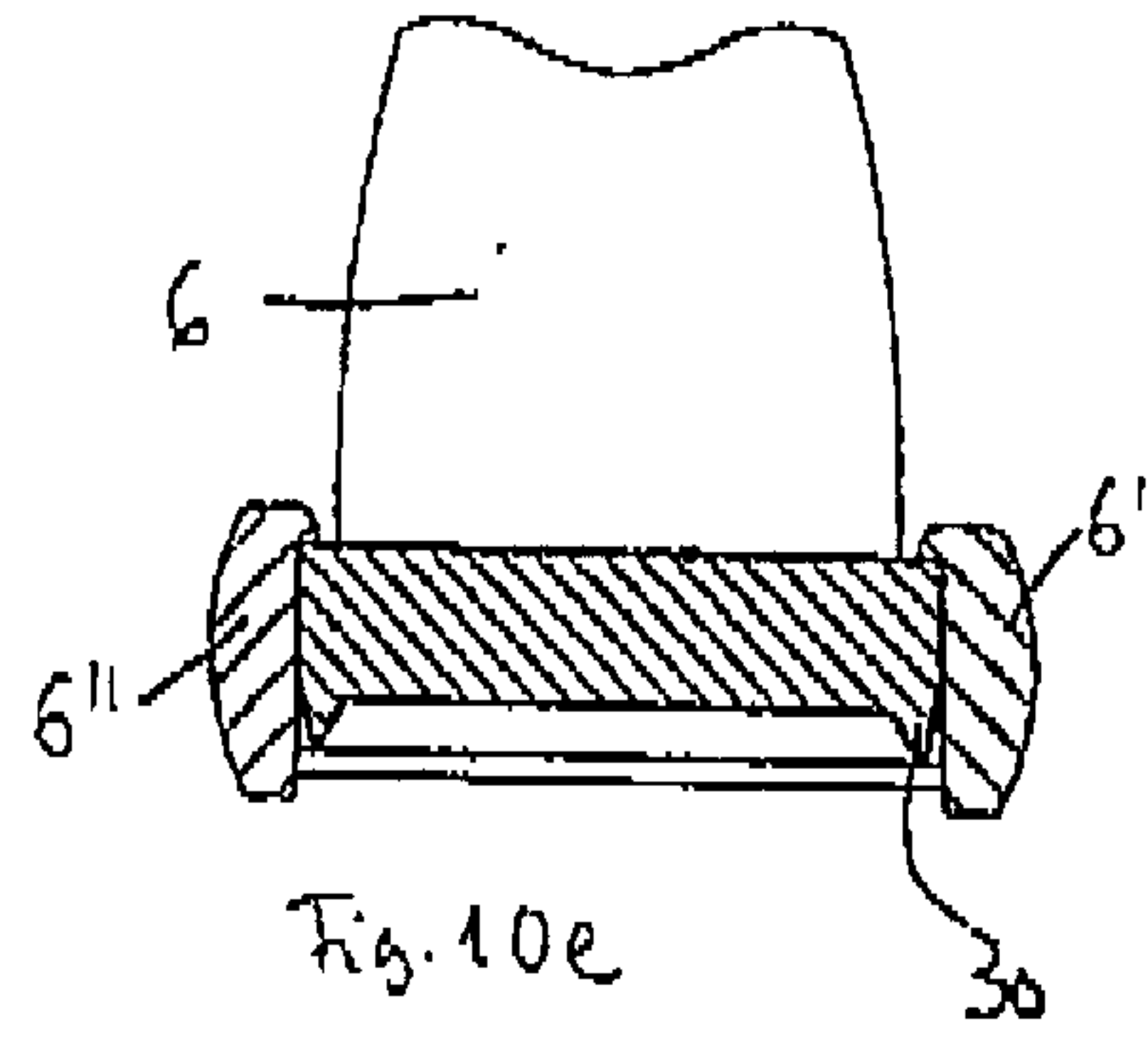
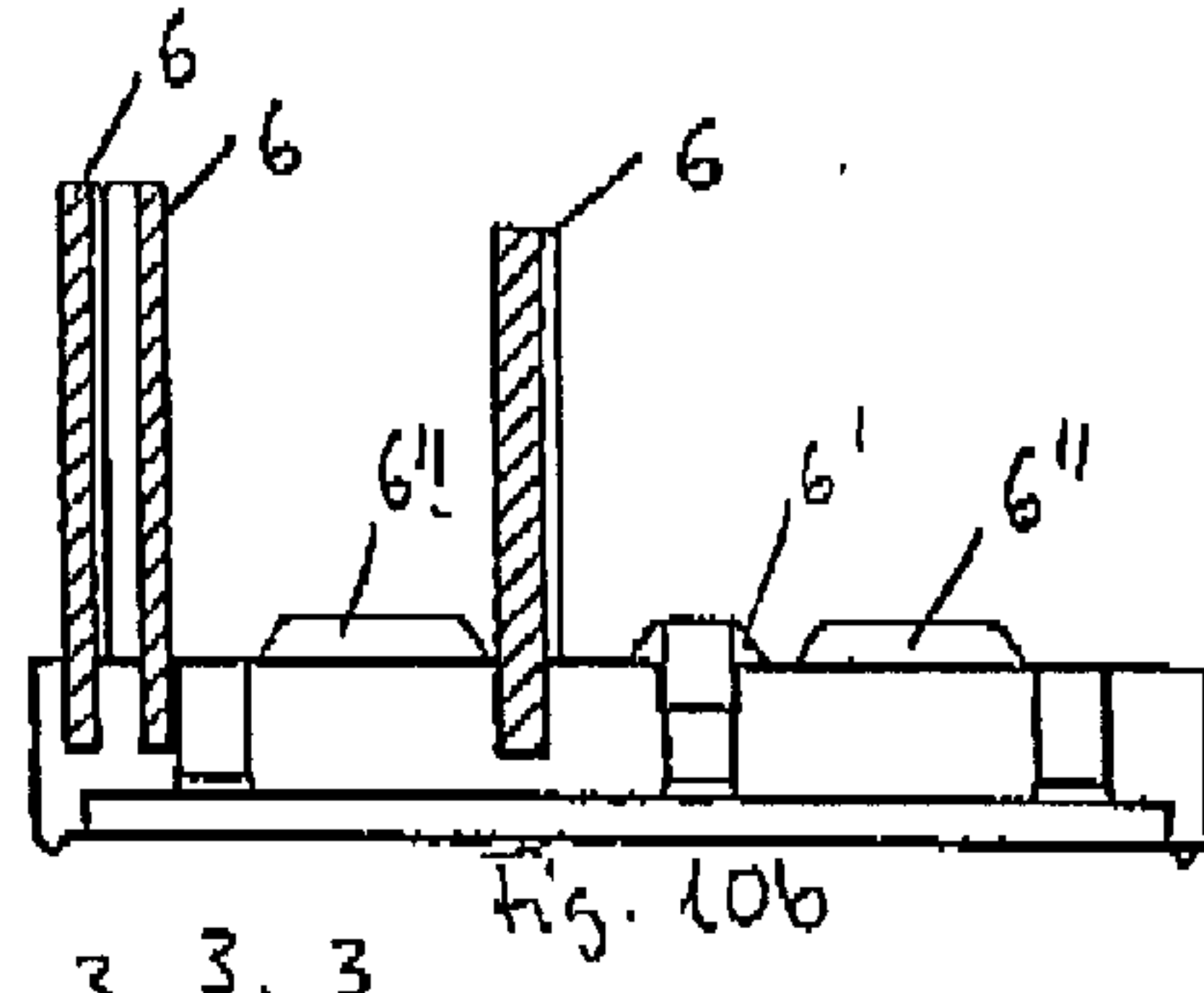
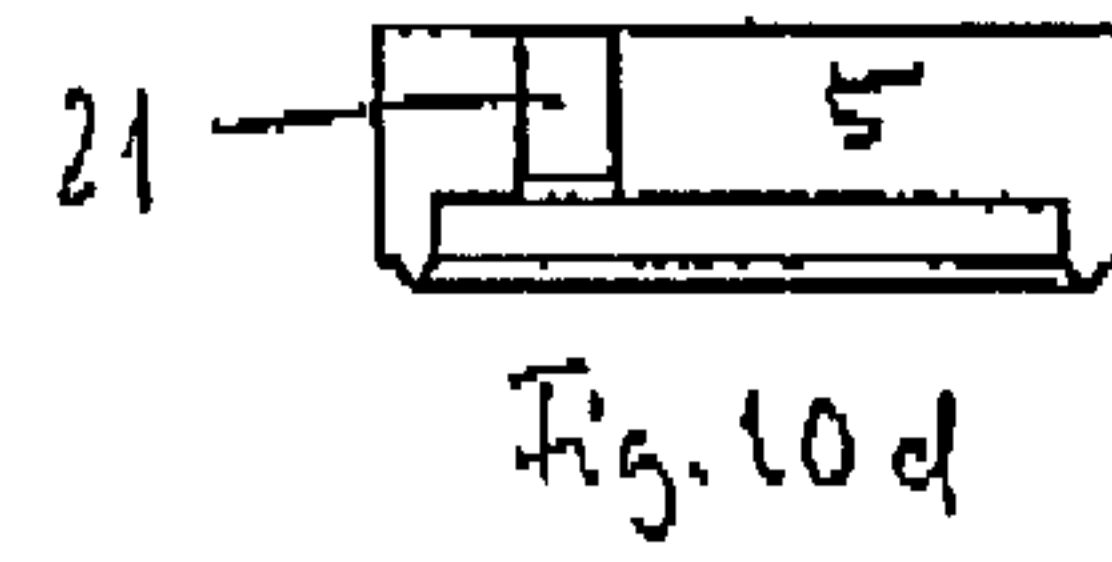
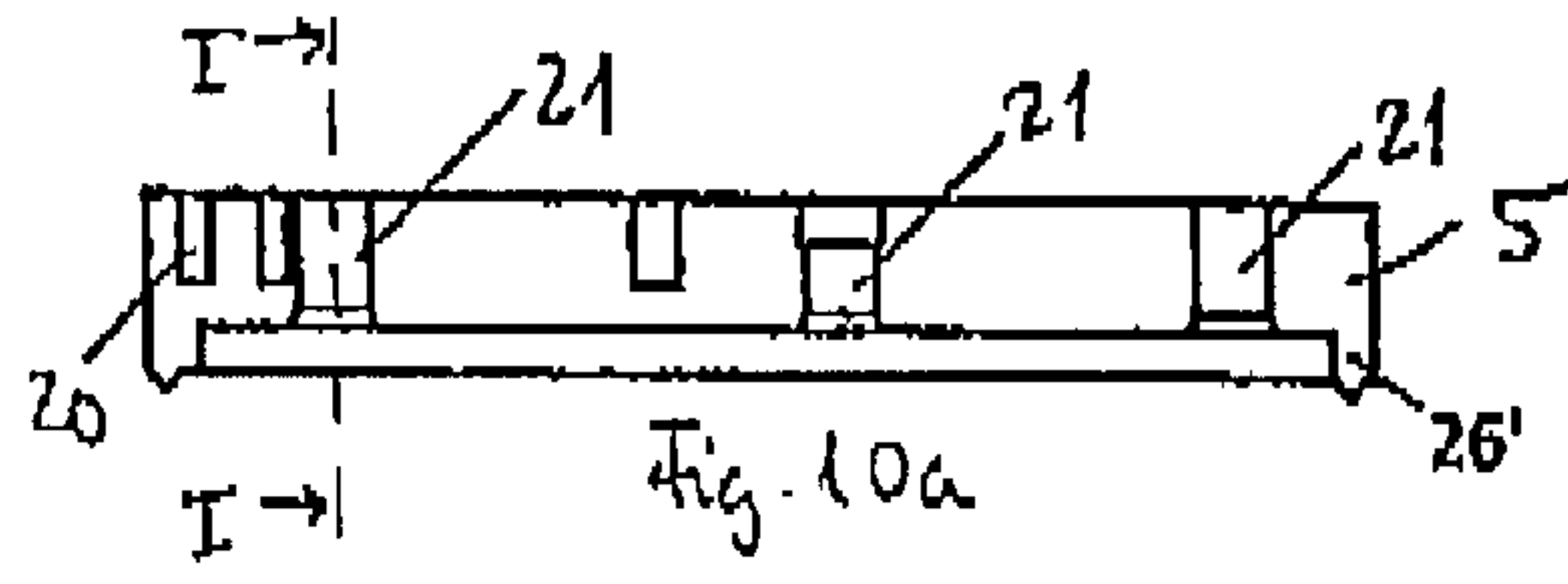

Fig. 9f



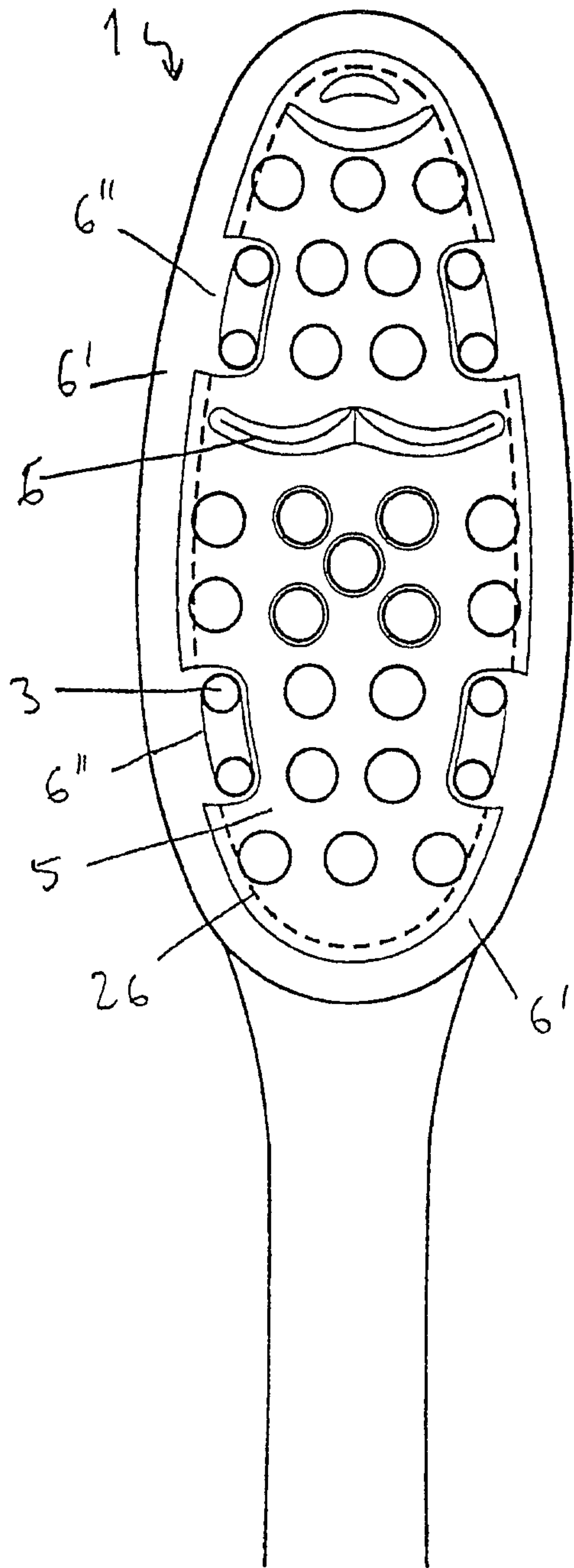

Fig. 11a

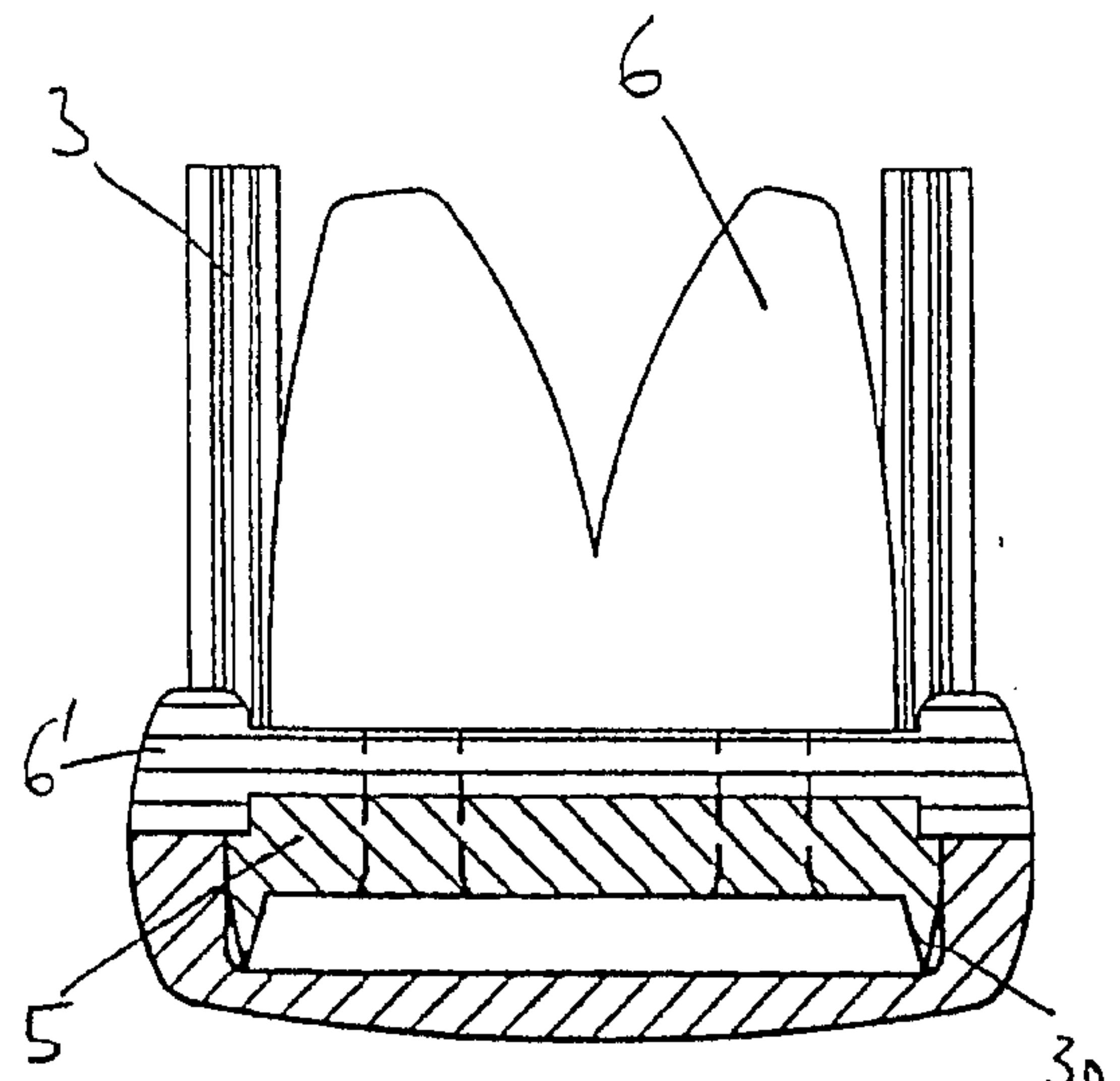

Fig. 11b

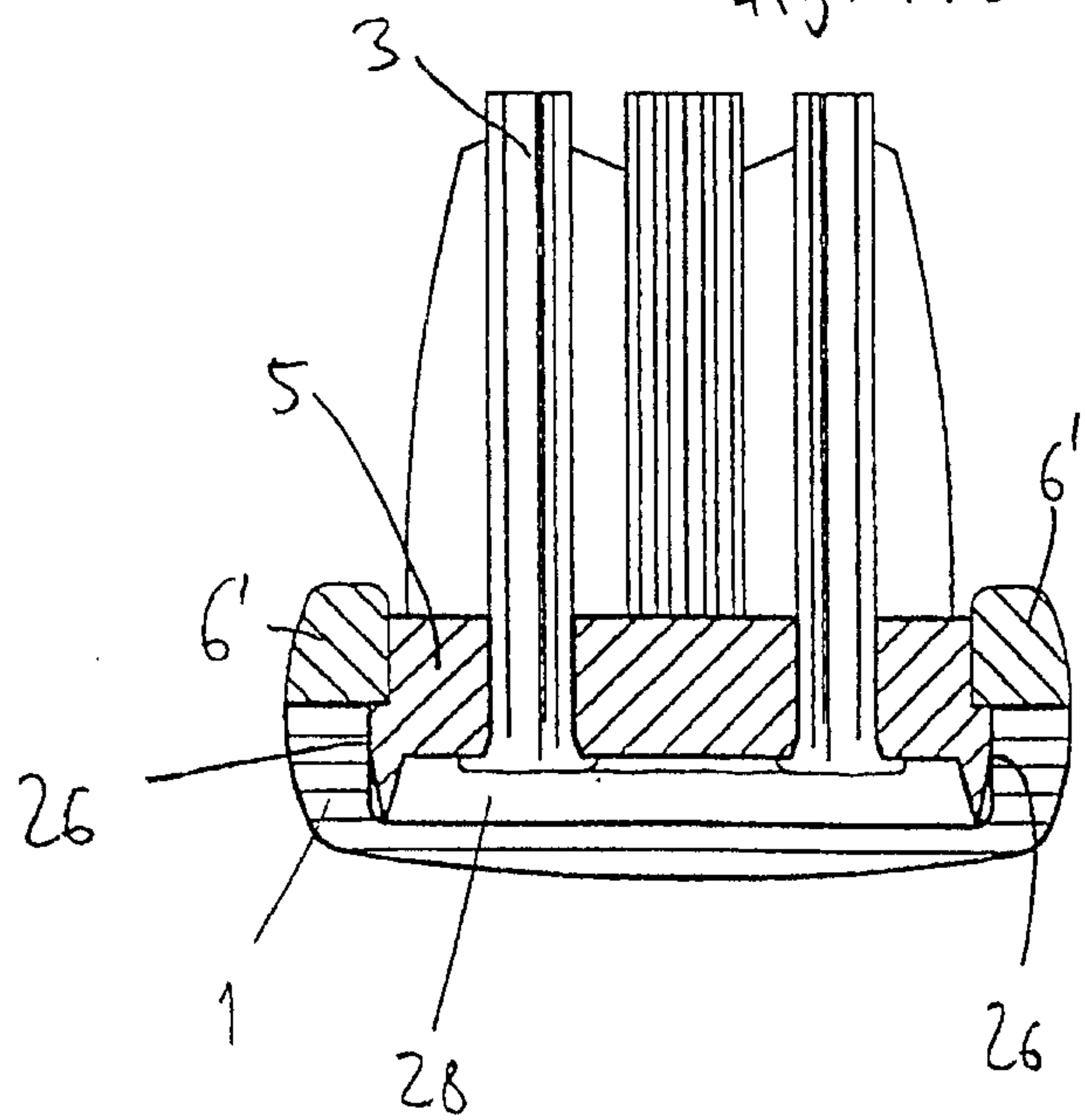

Fig. 11c

