

G. REHFUSS.

Sewing-Machine Tables.

No. 133,487.

Patented Nov. 26, 1872.

FIG. 1

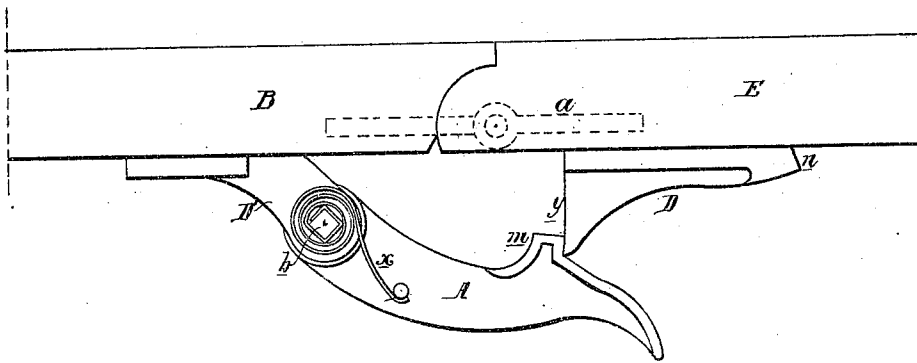
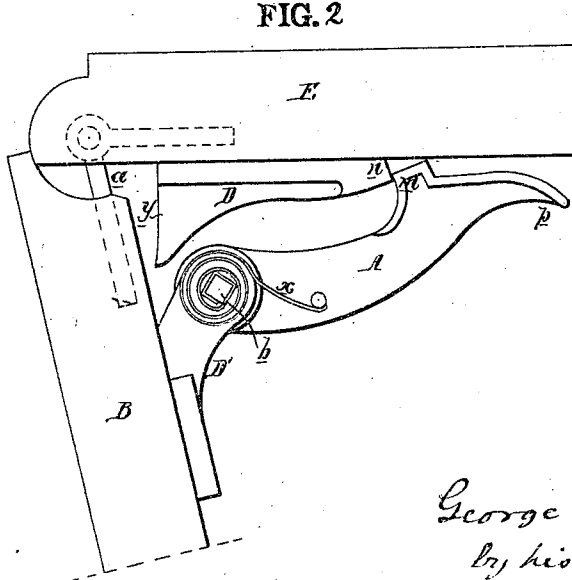

FIG. 2



George Rehfuss  
by his Attor.  
Horsman and Son.

WITNESSES. *Thomas M. Sloan*  
*John K. Rehfuss*

# UNITED STATES PATENT OFFICE.

GEORGE REHFUSS, OF PHILADELPHIA, PENNSYLVANIA, ASSIGNOR TO AMERICAN BUTTON-HOLE AND OVERSEAMING SEWING-MACHINE COMPANY, OF SAME PLACE.

## IMPROVEMENT IN SEWING-MACHINE TABLES.

Specification forming part of Letters Patent No. **133,487**, dated November 26, 1872.

*To all whom it may concern:*

Be it known that I, GEORGE REHFUSS, of Philadelphia, Pennsylvania, have invented an Improvement in Sewing-Machine Stands, of which the following is a specification:

The object of my invention is to retain the extension flap of a sewing-machine table in an elevated as well as a depressed position. This object I attain by the combination of a spring-catch lever, A, hinged to the under side of the extension flap B with a stop, D, secured to the under side of the permanent top E of the table, as shown in Figure 1 of the accompanying drawing. The flap B is connected to the top E of the table, as shown in dotted lines, and to a fixed pin, *b*, in a bracket, D', on the under side of the flap, is hinged a lever, A, which a coiled spring, *x*, attached to the said pin *b*, tends to elevate. When the flap B is raised so as to form a continuation of the permanent top E of the table it is retained in that position by the end *y* of the stop D, against which a projection, *m*, on the lever bears. On depressing the lever the flap will fall, and on moving it to the inclined position shown in Fig. 2, so that its lower end will be close to the frame of the sewing-machine stand, the projection *m* of the lever will catch against the rear end *n* of the stop D, thereby retain-

ing the flap in a position where it presents the least inconvenience to the sewing-machine operator.

It will be observed that the outer end of the catch-lever is so curved that it can easily be manipulated, and that the under side of the stop consists of a curved rib, so that when the flap B falls the projection *m* of the lever can slide freely over and in contact with the rib, which may be simply inclined instead of curved, until it is self-locked to the rear end of the stop.

I claim as my invention—

1. The combination, substantially as described, of the hinged extension flap B and spring-catch lever A with a stop, D, on the top E, or other permanent part of a sewing-machine stand.
2. The projection *m* of the said spring-lever, in combination with the ends *y* and *n* of the stop and the curved or inclined rib between the same.

In testimony whereof I have signed my name to this specification in the presence of two subscribing witnesses.

GEO. REHFUSS.

Witnesses:

JOHN POLLER,  
JOHN SHERBORNE SINGER.