

C. P. HIGGINS.

MACHINE FOR SPREADING ENDS OF HEADERS OR TUBES.

No. 524,324.

Patented Aug. 14, 1894.

Fig. 3.

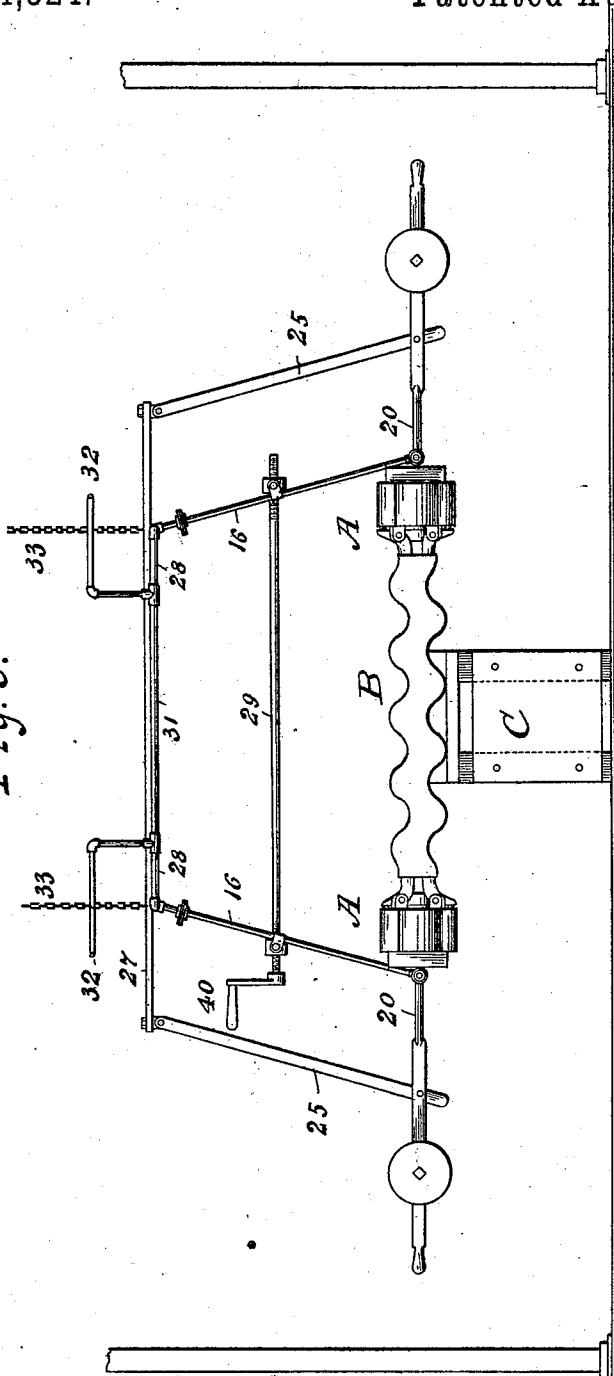

Witnesses
 Chas. Hanemann
 N. Marler

Inventor
Campbell P. Higgins
 By his Attorney
Chas W. Jordan

(No Model.)

3 Sheets—Sheet 3.

C. P. HIGGINS.

MACHINE FOR SPREADING ENDS OF HEADERS OR TUBES.

No. 524,324.

Patented Aug. 14, 1894.

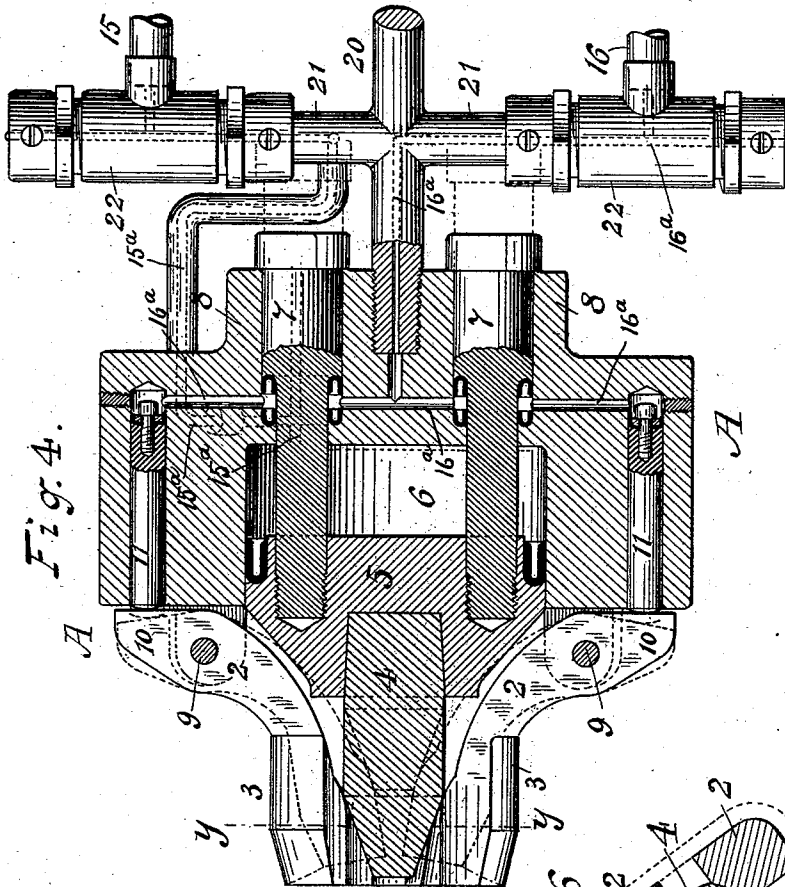

Fig. 4.

A

A

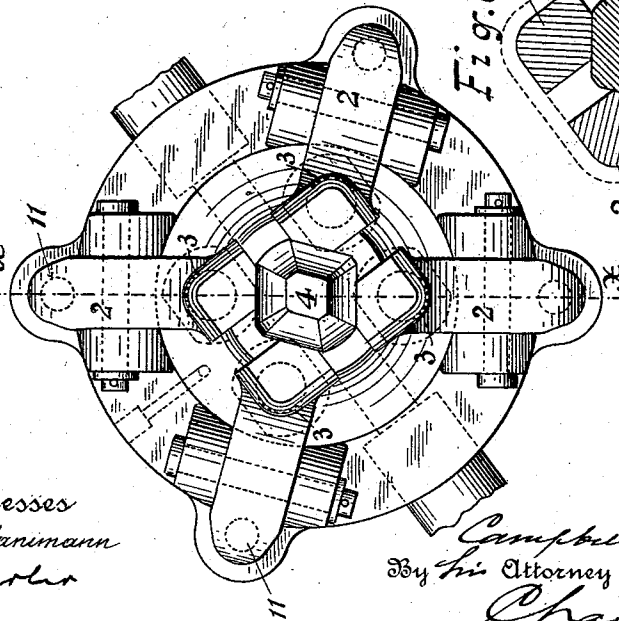

Fig. 5.

Fig. 6.

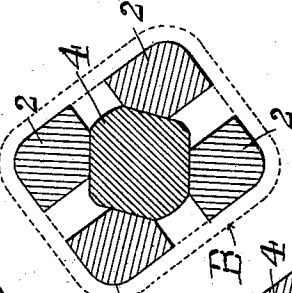
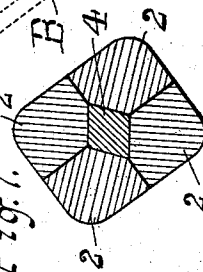

Fig. 7.



Witnesses
 Chas Hanemann
 W. Marler

Inventor
 Campbell P. Higgins
 By His Attorney
 Chas W. Torber

UNITED STATES PATENT OFFICE.

CAMPBELL P. HIGGINS, OF NEW YORK, N. Y.

MACHINE FOR SPREADING ENDS OF HEADERS OR TUBES.

SPECIFICATION forming part of Letters Patent No. 524,324, dated August 14, 1894.

Application filed July 5, 1892. Serial No. 439,064. (No model.)

To all whom it may concern:

Be it known that I, CAMPBELL P. HIGGINS, a citizen of the United States, residing in the city, county, and State of New York, have invented certain new and useful Improvements in Machines for Spreading the Ends of Headers or Tubes, of which the following is a specification.

The invention is designed to be used in the manufacture of headers for sectional steam boilers, but may be employed in other metallic boxes which are made from a tube of any cross-sectional form.

The object of the invention is to provide an apparatus adapted to expand the open ends of the tubes when heated preparatory to inserting and welding the ends for closing the same; and in order that others may understand and use the invention, I will first proceed to describe the construction and operation of a machine embodying it and subsequently point out in the claims its novel features.

Referring to the accompanying drawings, in which similar characters of reference indicate corresponding parts throughout the several views:—Figure 1, is a general elevation, showing two expanders, and the apparatus for manipulating the same; and Fig. 2, an end elevation of Fig. 1. Fig. 3, is a partial elevation showing the parts in Fig. 1, in the position of insertion into the ends of the tube. Fig. 4, is an enlarged section taken on the line $x-x$, Fig. 5, showing one of the expanders in detail. Fig. 5, is an end elevation of Fig. 4. Fig. 6, is a cross-section taken on the line $y-y$, Fig. 4; and Fig. 7, a similar section showing the parts closed.

A, A, Figs. 1 and 2, represent the expanders which for convenience are employed in duplicate, the one facing the other, adapted for simultaneous insertion into both extremities of the header or tube B, which is placed in position upon a stand C, for the purpose. The flexible connections for supporting the expanders A, above the stand will be more fully hereinafter described.

Reference now being made to Figs. 4, to 7, inclusive, the mechanism of the expander A, consists as follows:—Upon the body A, A, of the expander are four jaws 2, 2, 2, 2, pivoted at 9. The working faces 3, of the jaws 2, cor-

respond with the four corners of a quadrangular tube B, to be expanded, and the jaws 2, are so angularly placed as to draw the metal of the four sides of the quadrangle equally when expanded. Between the jaws 2, there is inserted a pyramidal steel wedge 4, acting on the interior faces of the said jaws, and the said wedge 4, is actuated by a ram 5, in the hydraulic cylinder 6. To the ram 5 are connected one or more retracting plungers 7, operating in the respective cylinders 8. The heels 10, of the jaws 2, are acted on by hydraulic plungers 11, which serve to contract the jaws 2, when the ram 5, and wedge 4, are retracted. All of the plungers thus described are suitably packed to be operated hydraulically, and passages and suitable means are provided for the admission and eduction of the water. A pipe 15, is provided for the admission and eduction of the actuating fluid for the expanding ram 5; suitable connecting passages 15^a being indicated; and a pipe 16 is provided for the admission and eduction of the actuating fluid for the retracting plungers 7, and 11, also provided with suitable passages 16^a.

22, 22, are rotary water joints of any suitable or usual construction.

Referring now to Figs. 1, 2 and 3, the stocks 20, bearing the expanders A, are suspended and counter balanced so as to be maintained in all positions in a horizontal direction upon flexible connections, which consist in the bars 25, and water pipes 15, 16, jointed to the horizontal bar 27, and pipes 28. A parallel motion is thus established, and the distance apart of the expanders A, A, is regulated by a screw rod 29, pivotally connected to the pipes 15, 16. The pipe sections 15, 16 are flexibly connected to the sections 28, by water collars 30, similar to those hereinbefore referred to. The middle section 31, of the pipe 28, is closed or composed of a solid bar, and the induction and eduction of the respective expanders independently effected through pairs of pipes 32.

The horizontal bar 27, of the operating frame is suspended upon chains 33, from a suitable overhead crane; each chain being connected over pulleys to a hydraulic operating cylinder 35, whereby the apparatus is raised or lowered and elevated out of the way

when not in use. Suitable valves and flexible connections are provided for supplying the pipes 32, and operating the cylinder 35, from any convenient position.

5 The spreading operation upon the end of the tube B, is preferably performed after the header has been corrugated by means of suitable mechanism, into the serpentine form indicated. The tube, after being heated, or
10 while still hot from the staggering press, is placed in position upon the stand C, and the expanding apparatus at the position indicated in Fig. 1, is lowered by means of the cylinder 35, and the expanders A, A, when
15 aligned with the ends of the tube are advanced by rotating the crank 40; the jaws 2, being preparatorily contracted for insertion. Pressure is then applied to the rams 5, expanding the jaws radially into each corner of
20 the open end of the header, producing a flared mouth of suitable size to receive the end piece which is to be placed and welded into it.

In the use of this invention, it is obvious that the expanding devices may be connected
25 with a fixed frame work and operated upon guide ways in lieu of the suspended frame work shown without departing from the spirit of the invention.

Having thus fully described my invention,
30 what I claim, and desire to secure by Letters Patent, is—

1. In a device for spreading tube ends, a series of radially movable jaws, a wedge adapted to expand the jaws, and a ram for
35 advancing and retracting the wedge, substantially as described.

2. In a device for spreading tube ends, a series of radially movable pivoted jaws, an

expanding ram acting on the jaws within the pivots, and a series of rams for retracting
40 the jaws, without the pivots, substantially as described.

3. In an apparatus for spreading tube ends, a pair of expanders arranged to operate at
45 opposite ends of the tube and connected means external to the tube for separating or advancing the expanders toward the tube ends.

4. An apparatus for spreading tube ends, comprising a pair of expanding devices and
50 means for drawing them toward one another simultaneously at opposite ends of the tube, and hydraulic rams with flexibly jointed tubing for conducting the fluid thereto, connected to the expanding devices for operat-
55 ing the same as set forth.

5. An apparatus for spreading tube ends, consisting of a pair of expanding devices, arranged to move in a plane with the tube, and
60 connected with hydraulic rams for operating the same suspended by the pressure pipes that conduct the fluid to operate the rams and means for adjusting the same, as set
65 forth.

6. A pair of hydraulic expanding devices
65 for spreading tube ends, mounted upon a jointed and balanced frame work, consisting in a horizontal bar, and means for elevating or lowering it, and pivoted suspensory bars supporting the expanders in parallel relation
70 at adjustable distances apart, and means for adjusting the said distances, as set forth.

CAMPBELL P. HIGGINS.

Witnesses:

S. M. PRATT,
FRANCIS L. WARD.