



(12) **DEMANDE DE BREVET CANADIEN  
CANADIAN PATENT APPLICATION**

(13) **A1**

(22) Date de dépôt/Filing Date: 2023/11/14  
(41) Mise à la disp. pub./Open to Public Insp.: 2024/06/23  
(30) Priorité/Priority: 2022/12/23 (EP22461652.4)

(51) Cl.Int./Int.Cl. *B64C 13/34* (2006.01),  
*F16H 49/00* (2006.01)  
(71) Demandeur/Applicant:  
HAMILTON SUNDSTRAND CORPORATION, US  
(72) Inventeurs/Inventors:  
CHMIELEWSKI, PAWEL, ALEKSANDER, PL;  
DARBY, JONATHAN A., GB;  
DAVIES, STEVE, GB;  
TUREK, LUKASZ, PL;  
CIS, MARCIN, PL;  
LUSZCZYK, KATARZYNA AGATA, PL  
(74) Agent: NORTON ROSE FULBRIGHT CANADA  
LLP/S.E.N.C.R.L., S.R.L.

(54) Titre : MECANISME D'ENTRAINEMENT A ONDES DE DEFORMATION  
(54) Title: STRAIN WAVE DRIVE

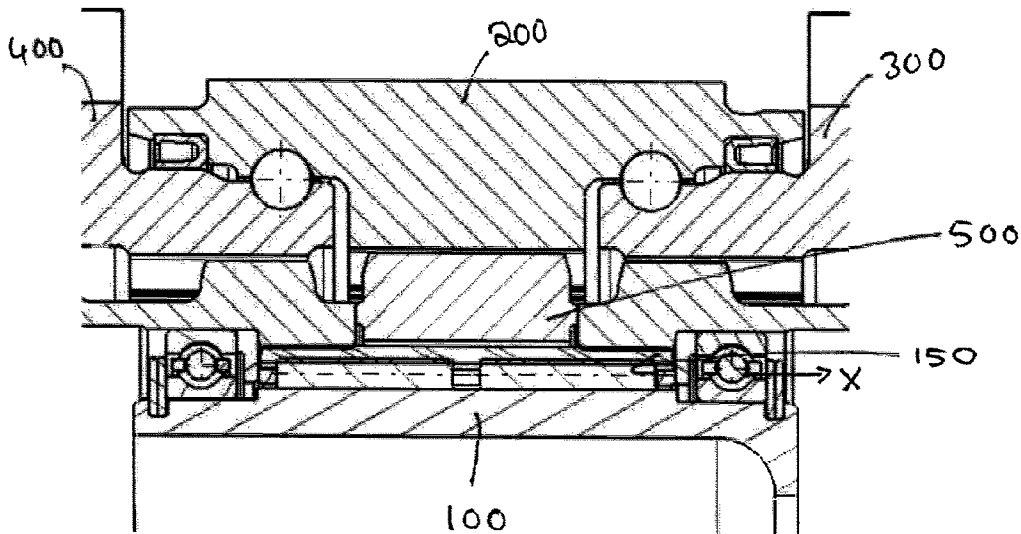

(57) **Abrégé/Abstract:**

A strain wave drive comprising: an elliptical wave generator shaft (100) rotatable about an axis (X); a flexible tubular flex spline (500) mounted around the wave generator shaft; a ring gear assembly mounted around the flex spline, the ring gear assembly comprising an output ring gear (200) having a circular inner periphery and being sandwiched between two earth ring gears (300, 400) each having a circular inner periphery; wherein the flex spline has a first number of radially outwardly extending teeth around its outer periphery; and wherein each earth ring gear has a first number of radially inwardly extending teeth to engage with the teeth of the flex spline; and wherein the output ring gear has a second number of radially inwardly extending teeth, wherein the second number is greater than the first number, such that as the wave generator shaft rotates, it causes the flex spline to take up the elliptical form of the wave generator shaft and the teeth of the flex spline engage with teeth of the output ring gear at the major diameter of the ellipse, causing the output ring gear to rotate.

## ABSTRACT

### STRAIN WAVE DRIVE

5 A strain wave drive comprising: an elliptical wave generator shaft (100) rotatable  
about an axis (X); a flexible tubular flex spline (500) mounted around the wave  
generator shaft; a ring gear assembly mounted around the flex spline, the ring gear  
assembly comprising an output ring gear (200) having a circular inner periphery and  
being sandwiched between two earth ring gears (300, 400) each having a circular  
10 inner periphery; wherein the flex spline has a first number of radially outwardly  
extending teeth around its outer periphery; and wherein each earth ring gear has  
the first number of radially inwardly extending teeth to engage with the teeth of the  
flex spline; and wherein the output ring gear has a second number of radially  
15 inwardly extending teeth, wherein the second number is greater than the first  
number, such that as the wave generator shaft rotates, it causes the flex spline to  
take up the elliptical form of the wave generator shaft and the teeth of the flex spline  
engage with teeth of the output ring gear at the major diameter of the ellipse,  
causing the output ring gear to rotate.

## STRAIN WAVE DRIVE

### 5 TECHNICAL FIELD

The present disclosure relates to a strain wave drive particularly a strain wave drive for rotary actuation of flight control surfaces of an aircraft.

### 10 BACKGROUND

Rotary actuation of devices or surfaces e.g. flight control surfaces in an aircraft, requires high torque drive and so typically requires gearing between the electric motor, which is typically high speed, low torque, and the output shaft of the actuator that drives the surface. Conventional involute gears, comprising a number of intermeshing toothed wheels to create the required gear ratio, are relatively large and heavy and the higher the required ratio, the more gears and, thus, the greater the size and weight of the overall actuator system.

20 In aircraft in particular, and also in other applications, there is a need to minimise the size and weight of components and there is a desire to provide a gear or drive that can provide the required torque ratio using a smaller, lighter, more compact arrangement.

25 A known type of gear mechanism that is particularly compact is the strain wave drive or gear. Strain wave gearing, also known as a harmonic drive, is used in many drive trains as it is compact and lightweight and can be used to provide a high gear ratio between an input or drive shaft and an output shaft. These properties make strain wave gearing suited to use in aircraft and other vehicles where space is limited and weight of components should be minimised, whilst maintaining reliability and performance.

30 A strain wave gear system includes a wave generator which is in the form of an elliptical shaft and a compliant ball bearing in which the elliptical shaft rotates. A flexible toothed ring (a flex spline) is mounted about the wave generator and

engages, and conforms to the shape of, the output shaft. A fixed outer ring, or circular spline is provided around the flex spline and has inner teeth that engage with the outer teeth of the flex spline but, due to the elliptical shape of the wave generator, the flex spline only engages with the teeth of the outer ring at the major diameter of the wave generator.

In operation, a drive shaft, connected to the wave generator, is rotated e.g. by a motor, which causes rotation of the wave generator. The bearing conforms to the elliptical shape of the wave generator. The flex spline conforms to the shape of the drive shaft and so as the wave generator rotates, the flex spline will only engage with the inner teeth of the outer ring at the major axes of the ellipse. The circular spline has a different number of inner teeth to the number of outer teeth of the flex spline. Rotation of the drive shaft thus causes a slower rotation of the output shaft by its engagement with the flex spline. The output shaft is connected to the device or surface to be moved by the actuator.

Known strain wave drives, however, have to be designed with built-in compliance (as discussed below) to ensure correct load distribution and engagement of the teeth. This adds to the costs and complexity of such gears for use in e.g. flight control rotary actuation. There is, therefore, a desire for an improved strain wave drive that retains the benefits of compactness and light weight whilst overcoming problems associated with existing strain wave drives.

#### SUMMARY

According to the disclosure, there is provided a strain wave drive comprising: an elliptical wave generator shaft rotatable about an axis; a flexible tubular flex spline mounted around the wave generator shaft; a ring gear assembly mounted around the flex spline, the ring gear assembly comprising an output ring gear having a circular inner periphery and being sandwiched between two earth ring gears each having a circular inner periphery; wherein the flex spline has a first number of radially outwardly extending teeth around its outer periphery; and wherein each earth ring gear has the first number of radially inwardly extending teeth to engage with the teeth of the flex spline; and wherein the output ring gear has a second number of radially inwardly extending teeth, wherein the second number is greater

than the first number, such that as the wave generator shaft rotates, it causes the flex spline to take up the elliptical form of the wave generator shaft and the teeth of the flex spline engage with teeth of the output ring gear at the major diameter of the ellipse, causing the output ring gear to rotate.

5 The second number of teeth is preferably more than the first number e.g. two or three more.

#### BRIEF DESCRIPTION

10 Examples of the strain wave drive according to the disclosure will now be described with reference to the drawings. It should be noted that these are examples only and variations are possible within the scope of the claims.

Figure 1A shows a cross-section through a known type of strain wave drive.

15

Figure 1B shows a detail of the strain wave drive of Fig. 1A.

Figure 2 shows a strain wave drive such as shown in Figs. 1A and 1B during deflection of the flex spline.

20

Figure 3 shows in close up the intermeshing teeth of the strain wave gear as shown in Fig. 2.

Figure 4 shows an example of a strain wave drive in accordance with the present disclosure.

25

Figures 5A, 5B and 5C show a strain wave drive in accordance with the disclosure from different views.

#### 30 DETAILED DESCRIPTION

As mentioned above, conventional drives for moving e.g. flight control surfaces in aircraft, have used a series of inter-meshing gear wheels. In an attempt to reduce the overall size and weight of the gearing, thought has been given to the use of the more compact strain wave gears or drives (also known as harmonic drives). Such

35

strain wave drives essentially consist of three main parts: a wave generator, driven by the motor drive shaft, is an elliptical shaft having bearings arranged around the outer perimeter thereof. The wave generator is located within a cylindrical flex spline which is a flexible annular component having radially outwardly extending teeth. The flex spline is sufficiently flexible to take up the elliptical shape of the wave generator as the wave generator and its bearings rotate within the flex spline. A rigid circular spline is a ring that fits around the flex spline. The circular spline has inwardly extending teeth. The circular spline is typically fixed e.g. to the actuator housing. As the wave generator is rotated by the motor, it causes the flex spline to take up the elliptical shape such that the outwardly extending teeth of the flex spline mesh with the inwardly extending teeth of the circular spline at the locations of the major axis of the ellipse. The circular spline typically has more teeth than the flex spline such that as the teeth engage, the flex spline is caused to rotate relative to the circular spline at a rate of rotation different to that of the motor. In other applications, such as shown in Fig. 1A, an output ring gear is positioned around the cup-shaped flex spline. The output ring gear is provided with inner teeth that engage with the teeth of the flex spline. As the flex spline deforms due to rotation of the wave generator inside it, its teeth engage with the inwardly protruding teeth of the output ring and, due to the elliptical movement of the point of engagement, this causes the output ring gear to rotate according to the gear ratio. The output ring gear is connected with a part or component to be moved by the drive.

Current designs of strain wave drives for rotary actuation of flight control surfaces require a right-angled U-shaped or cup-shaped flex spline to provide the flex spline function within the available space envelope and with the required strength and stress resistance. A flat flex spline would need to be excessively long to provide the required function, and this would not be sufficiently strong and would not fit within the available envelope. The right-angle cup shape adds stiffness and distributes stress through the earthed parts of the system. An example of such a strain wave drive is shown in Figs. 1A and 1B. Because the flex spline is cup-shaped, it has to be formed as two cup parts for manufacturing and assembly purposes, the two cup parts meeting at a join aligned with the output ring gear sandwiched between the earth gears.

Figure 1A shows a section of the strain wave drive, showing the wave generator 1, rotatable about axis A. Needle bearings 2 are provided around the perimeter of the

5 wave generator 1. The flex spline 3 is fitted around the wave generator to engage with the bearings to take up the elliptical shape of the wave generator. In the example shown, two flex splines are provided, each formed with a flange 30. Teeth (not shown in this figure) on the outer surface of the flex spline engage, at certain positions of rotation, with inwardly extending teeth (not shown in this figure) of the output ring gear 4. The earth gears may be fixed relative to the actuator housing or other fixed component and the flex spline may engage with an output shaft or output ring gear 4 which is caused to rotate with rotation of the point of engagement with the flex spline as the wave generator rotates. The output gear rotates according to the gear ratio and may be fixed to a part or surface to be rotated e.g. a flight control surface.

15 Because there is uneven loading on the flex spline 3 between the wave generator, via the bearings, and the output gear, and equal loads are transmitted from the flex spline through the earth gears, deflection of the flex spline creates a 'coning' effect as shown in Fig. 2. The split, two-part flex spline forms a conical shape at its interface with the output gear and the earth gears which can cause an uneven interference between the inter-meshing teeth at some positions, i.e. when the flex spline deflects, it engages with the corresponding teeth at an angle as seen in Fig. 3. This angle may also vary under changing loads and temperatures.

20 Further, to allow the cup-shaped flex spline to deflect to take up the elliptical form to engage with the output ring gear, the supporting flanges need to be sufficiently long to accommodate the range of deflection. Having longer flanges, however, compromises the torsional stiffness and space taken up by the design.

30 To take into account the tilt between the meshing gears when the flex spline is deformed, compliance needs to be built into the design to ensure uniform load distribution from the parts that generate the motion of the gearing through to the flex spline itself.

35 To address these problems, the strain wave drive of this disclosure uses a straight flex spline (i.e. a tube shaped flex spline without flanges, together with two different ring gears (circular splines) using a design similar to known flat (FR) type harmonic drives. The strain wave gear has an output ring gear 200 and two earth gears 300,

400 arranged either side of the output ring gear 200, such that the output ring gear is sandwiched between the two earth gears 300, 400 as best seen in Fig. 5B.

5 The elliptical wave generator 100 is a shaft, rotatable about an axis X, and located within the flex spline 500 which is a tubular sleeve component. Mounted around the flex spline is the sandwich arrangement of the output ring gear 200 between the earth gears 300, 400.

10 The earth gears are provided with flanges 30, 40 to be mounted to a fixed, earthing part or surface. The output gear 200 is rotatable relative to the earth gears according to the gear ratio provided by the different numbers of teeth. The output gear 200 is also provided with a flange 20 for attachment to the movable part e.g. flight control surface.

15 The output ring gear 200 has two teeth more than the flex spline 500 and this provides the gear ratio. The earth rings 300, 400 each have the same number of teeth as the flex spline such that the flex spline cannot rotate relative to the earth rings.

20 As the elliptical wave generator rotates, the outer sections of the flex spline are secured by the earth gears and, at the major diameter of the ellipse, the middle section of the flex spline is deformed to take up the elliptical shape and its teeth, in that section, mesh with the teeth of the output gear causing it to rotate.

25 With this design, the flex spline 500 can be deformed along its whole length which eliminates the coning effect. Further, because only the engaging part of the flex spline is being deflected, it does not need to be very long to provide compliance and so the design is very compact.

30 An arrangement according to the disclosure is shown in cross-section in Fig. 4

The wave generator 100 is shown and is rotatable about axis X, the wave generator is elliptical and has rollers e.g. needle rollers 150 around its periphery. The flex spline 500 takes the elliptical shape of the wave generator and therefore engages  
35 with the teeth on the output gear 200 at the points of the ellipse major axis.

Because the output gear has two more teeth than the flex spline, there is relative movement in the rotational direction between the flex spline and the output gear – i.e. the output ring gear rotates. The flex spline has the same number of teeth as the earth gears and so there is no relative movement.

5

Because of the balanced design with the earth gears on both sides of the output gear and, therefore, the flex spline, no coning effect occurs. It is not, therefore, necessary to provide compliance in the other components of the drive such as the bearings or the shaft to compensate for such coning. No skewing occurs and no flanges are needed to fix the flex spline. The compact design of the strain wave drive is simpler and less expensive and time consuming to manufacture and assemble and, requiring fewer parts, is less vulnerable to fault or wear.

10

CLAIMS

1. A strain wave drive comprising:  
an elliptical wave generator shaft (100) rotatable about an axis (X);  
5 a flexible tubular flex spline (500) mounted around the wave generator shaft;  
a ring gear assembly mounted around the flex spline, the ring gear  
assembly comprising an output ring gear (200) having a circular inner  
periphery and being sandwiched between two earth ring gears (300, 400)  
each having a circular inner periphery;  
10 wherein the flex spline has a first number of radially outwardly extending  
teeth around its outer periphery; and  
wherein each earth ring gear has the first number of radially inwardly  
extending teeth to engage with the teeth of the flex spline; and  
wherein the output ring gear has a second number of radially inwardly  
15 extending teeth, wherein the second number is greater than the first  
number, such that as the wave generator shaft rotates, it causes the flex  
spline to take up the elliptical form of the wave generator shaft and the teeth  
of the flex spline engage with teeth of the output ring gear at the major  
diameter of the ellipse, causing the output ring gear to rotate.  
20
2. The strain wave drive of claim 1, wherein the second number is two more  
than the first number.
3. The strain wave drive of claim 1, wherein the second number is three more  
than the first number  
25
4. The strain wave drive of any preceding claim, further comprising bearings  
(150) between the wave generator shaft and the flex spline.
5. The strain wave of claim 4, wherein the bearings are needle roller bearings.  
30
6. The strain wave of any preceding claim, wherein the earth ring gears are  
configured to be attached to an external fixed part.
7. The strain wave drive of claim 6, wherein the earth ring gears are provided  
35 with attachment flanges (30, 40) for attachment to the external fixed part.

8. The strain wave drive of any preceding claim, wherein the output ring gear is configured to be attached to a part or component to be moved.
- 5 9. The strain wave drive of claim 8, wherein the output ring gear is provided with a flange (20) for attachment to the part or component to be moved.
- 10 10. The strain wave drive of any preceding claim for moving a moveable part or component of an aircraft.
- 10 11. The strain wave drive of claim 10 for moving a flight control surface of an aircraft.

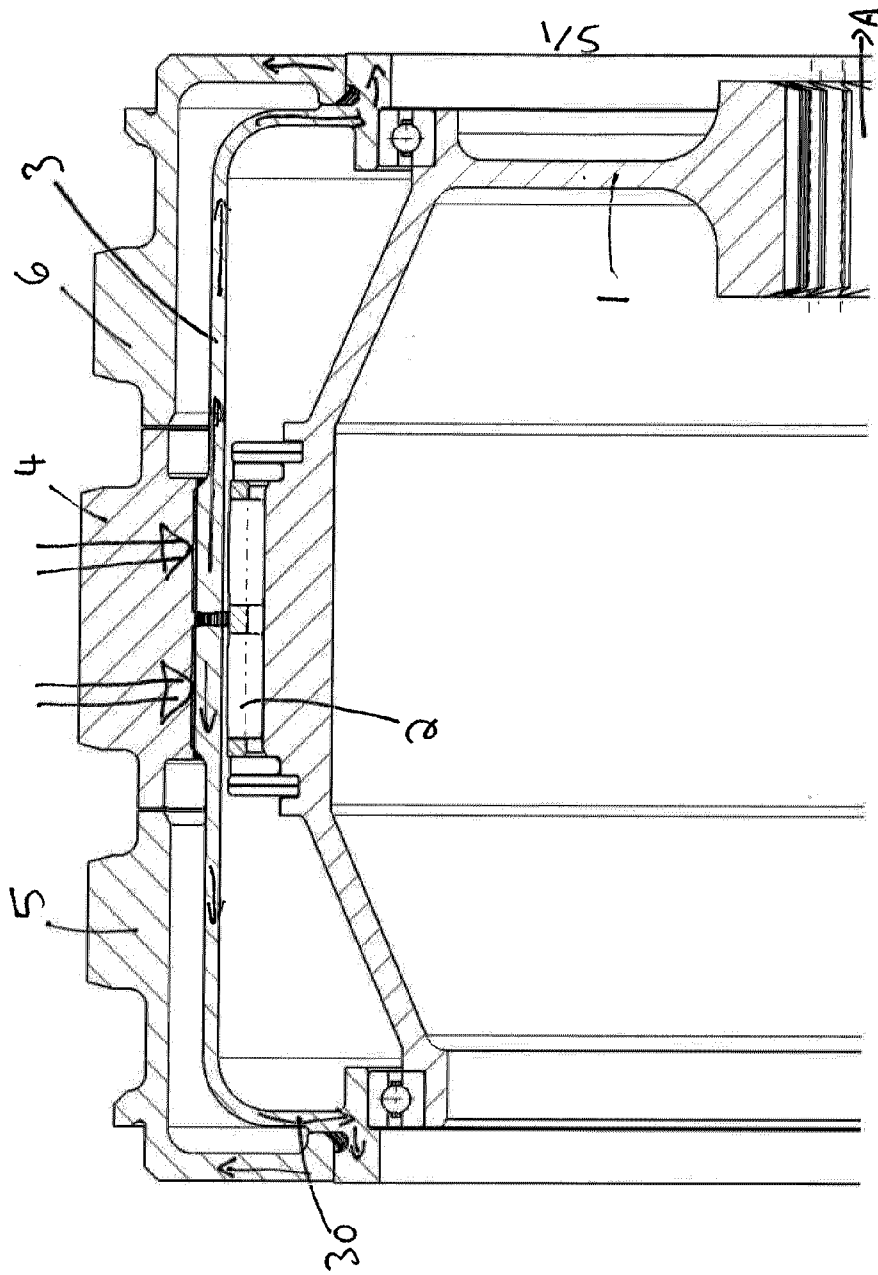

FIG. 1A

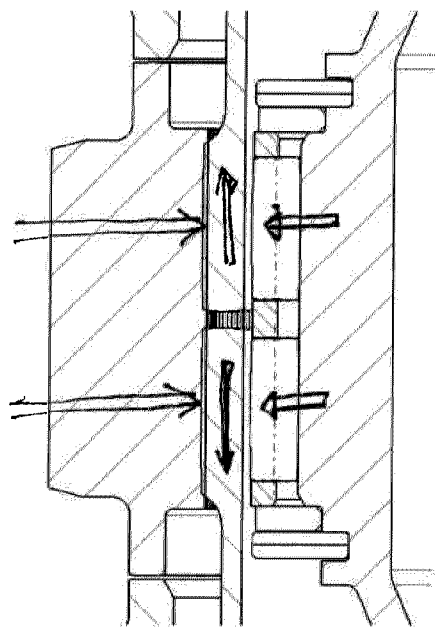

FIG. 1B

215

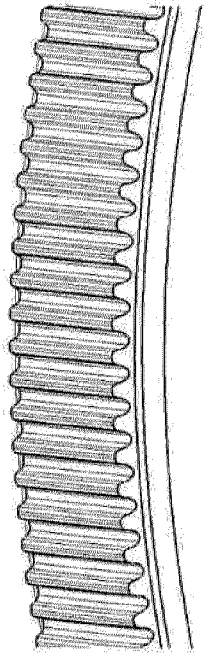

FIG. 3

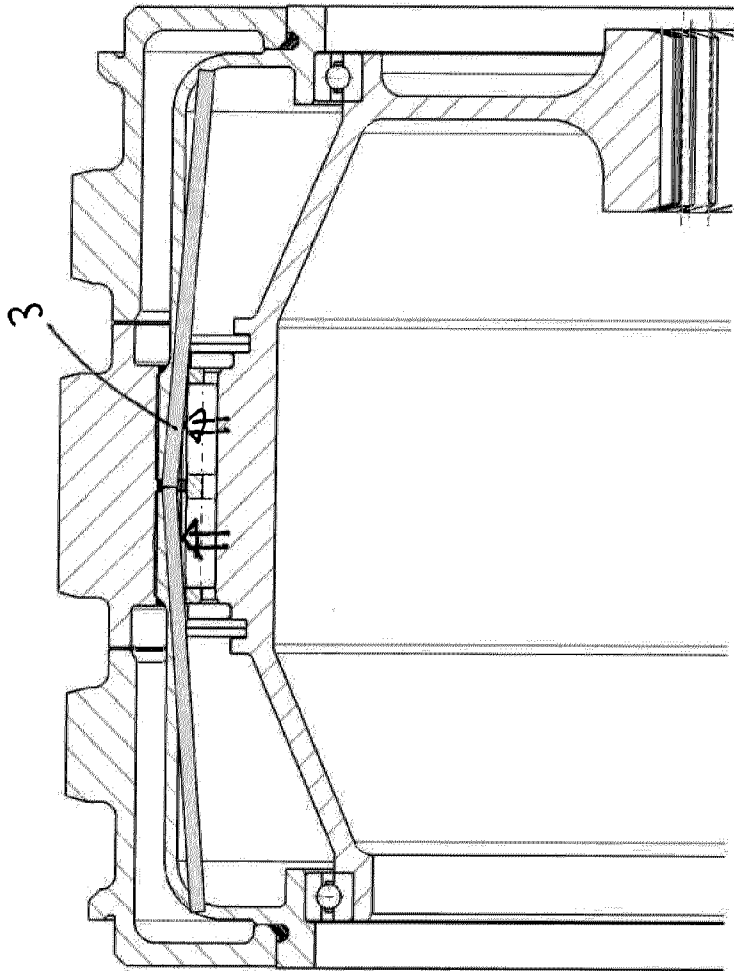

FIG. 2

315

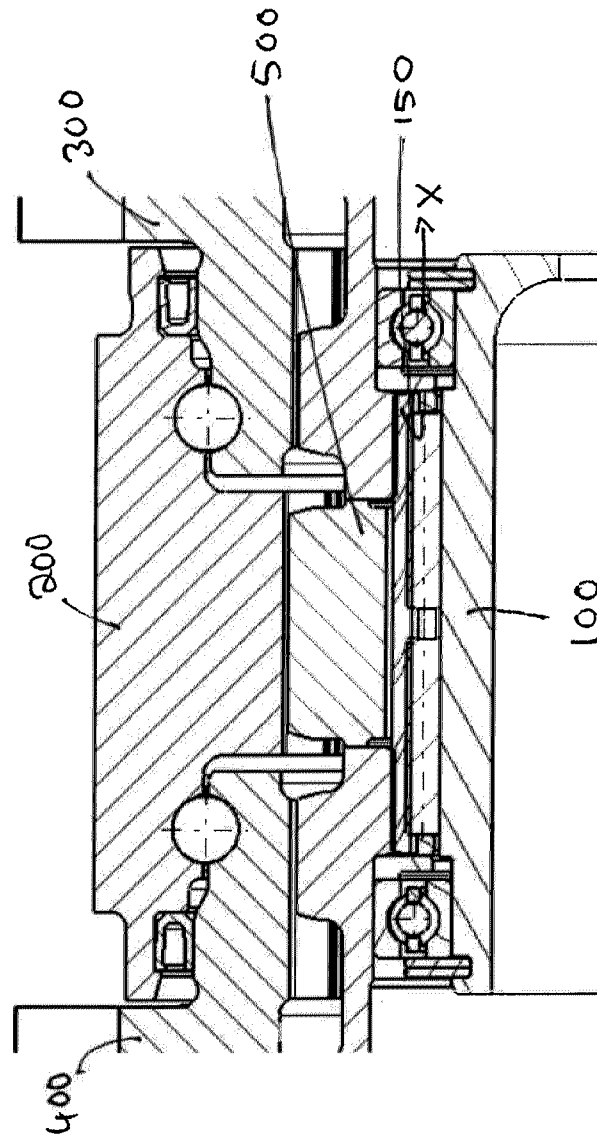
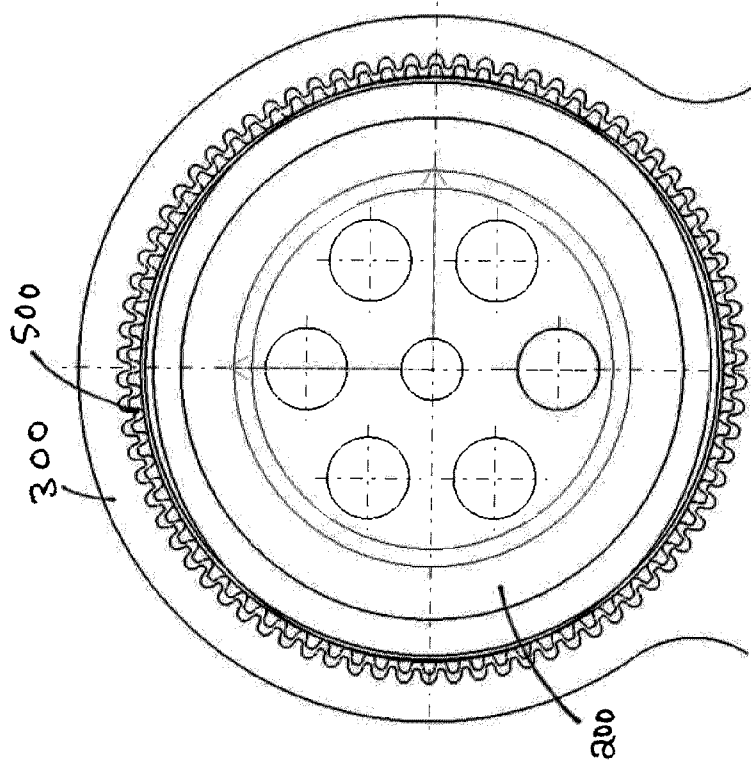
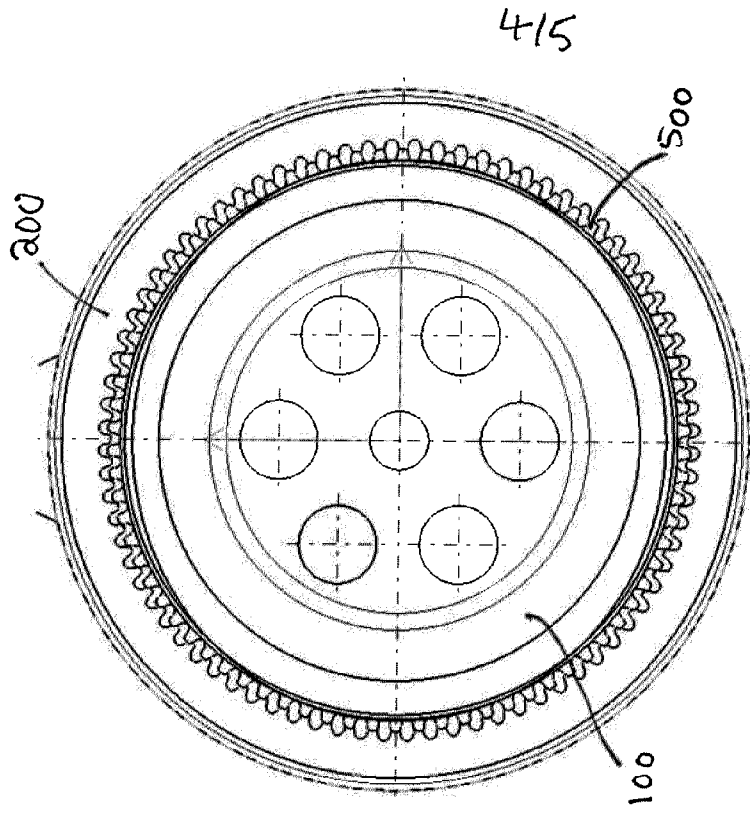

FIG. 4



Earth Gear

FIG. 5A



Output Gear

FIG. 5C

