



(51) International Patent Classification:

A61C 1/16 (2006.01) B65B 53/00 (2006.01)
A61B 1/00 (2006.01) A61B 19/02 (2006.01)
B29C 55/24 (2006.01) A61B 19/04 (2006.01)

(21) International Application Number:

PCT/TR2015/000250

(22) International Filing Date:

4 June 2015 (04.06.2015)

(25) Filing Language:

English

(26) Publication Language:

English

(30) Priority Data:

2014/06485 6 June 2014 (06.06.2014) TR

(72) Inventor; and

(71) Applicant : ÖZKARSLI, Şükrü Fatih [TR/TR]; Nispetiye Cad Çamlık Mevkii Aslanlı, Apt. No:1 D:5-6 Hoşgör Beşiktaş, İstanbul (TR).

(74) Agent: DESTEK PATENT, INC.; Konak Mah. Lefkoşe Cad., NM Ofis Park B Blok No:36/5, Beşevler Nilüfer, 16110 Bursa (TR).

(81) Designated States (unless otherwise indicated, for every kind of national protection available): AE, AG, AL, AM, AO, AT, AU, AZ, BA, BB, BG, BH, BN, BR, BW, BY, BZ, CA, CH, CL, CN, CO, CR, CU, CZ, DE, DK, DM, DO, DZ, EC, EE, EG, ES, FI, GB, GD, GE, GH, GM, GT, HN, HR, HU, ID, IL, IN, IR, IS, JP, KE, KG, KN, KP, KR, KZ, LA, LC, LK, LR, LS, LU, LY, MA, MD, ME, MG, MK, MN, MW, MX, MY, MZ, NA, NG, NI, NO, NZ, OM, PA, PE, PG, PH, PL, PT, QA, RO, RS, RU, RW, SA, SC, SD, SE, SG, SK, SL, SM, ST, SV, SY, TH, TJ, TM, TN, TR, TT, TZ, UA, UG, US, UZ, VC, VN, ZA, ZM, ZW.

(84) Designated States (unless otherwise indicated, for every kind of regional protection available): ARIPO (BW, GH, GM, KE, LR, LS, MW, MZ, NA, RW, SD, SL, ST, SZ, TZ, UG, ZM, ZW), Eurasian (AM, AZ, BY, KG, KZ, RU,

[Continued on next page]

(54) Title: PROTECTIVE COVER COATING DEVICE

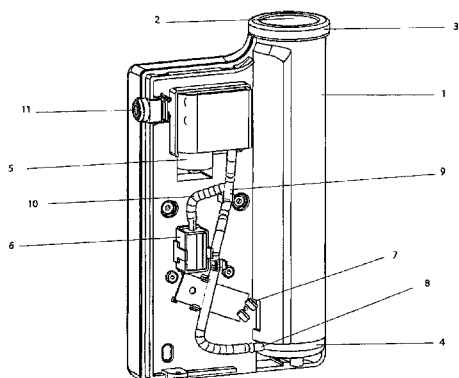

Figure 1c

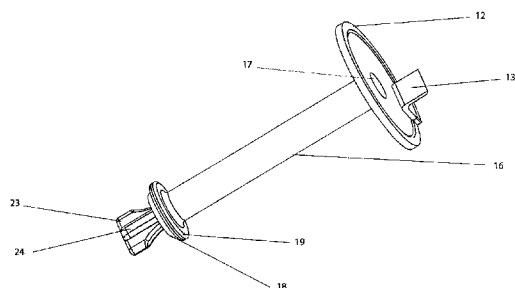

Figure 2c

(57) Abstract: The invention is related to a coating device (A) that allows for coating the surface of devices and tools in direct/indirect contact with the patient in medical and dental areas, to the coating method that is performed with the coating device (A) and to the method for removing the protective cover (16) from the coated devices.

TJ, TM), European (AL, AT, BE, BG, CH, CY, CZ, DE, DK, EE, ES, FI, FR, GB, GR, HR, HU, IE, IS, IT, LT, LU, LV, MC, MK, MT, NL, NO, PL, PT, RO, RS, SE, SI, SK, SM, TR), OAPI (BF, BJ, CF, CG, CI, CM, GA, GN, GQ, GW, KM, ML, MR, NE, SN, TD, TG).

Published:

- *with international search report (Art. 21(3))*
- *before the expiration of the time limit for amending the claims and to be republished in the event of receipt of amendments (Rule 48.2(h))*

DESCRIPTION

Protective Cover Coating Device

5 **Technical Field**

The invention is related to a coating device that is used for coating devices and tools utilized in medical and dental areas and to the coating method that is performed using said coating device.

10 The invention is particularly related to a coating device which allows for coating the surface of devices and tools that are in direct or indirect contact with the patient in medical and dental areas with a latex or similar flexible protective cover which may or may not be sterile and to the coating/removing method that is performed with said coating device.

15 **State of the Art**

Today, fast spreading of viral and communicable diseases threatens the assisting staff and the patients as well as the doctors in the medical and dental working environments. Besides, similar cases are experienced in the tools used for tattooing.

20

Especially, surfaces of the devices and tools used for treatment in dental offices are contaminated with blood, saliva, debris and other microbial wastes, and it leads to cross-transmission of pathogenic microorganisms from patient to doctor, patient to assisting staff or patient to patient.

25

In doctors' offices, it is recommended to use autoclave in order to sterilize those devices and tools which are in direct contact with the oral cavity and suitable for autoclave sterilization. It is required to clean the devices thoroughly before entering the autoclave. However, standard autoclaves employed only provide sterilization and the cleaning process is performed manually. And, manual cleaning is a long and difficult process. Besides, the assisting staff's attention and sensitivity is trusted with this cleaning process which is quite important.

30

Devices such as dental high speed handpiece, electric micromotor, surgical handpiece, ultrasonic scaler, light curing device, and intra-oral camera which are in direct contact with the oral cavity and cannot always be sterilized completely in the autoclave due to their complex designs and electronic components. In order to sterilize said devices in the autoclave after each patient and to re-use them, the number of each device available in the

35

doctor's office should be at least 50-100 which is almost impossible because of the high costs of these devices.

5 Due to the abovementioned disadvantages, some solutions are proposed to protect dental and medical devices with a protective cover. One of the patents with respect to the subject matter in the literature is the application No. US 8235720B1. Said application relates to a cover used to provide hygiene for a dental device. The cover of the invention comprises some components also to contribute to the dental operation.

10 The patent No. FR2908037 is related to a protection assembly that is used to provide hygiene for syringes especially utilized in a dental environment.

Some US patent applications with respect to the subject matter are the applications numbered as follows: US1485963, US2073137, US4728290, US4789336, US5228851, and
15 US6350124. However, the protective covers proposed for dental handpieces in these applications are produced specifically for each device. The covers designed individually for each device restrict the area of use of the covers. Moreover, it is required to coat said protective covers by manual manipulation. Then again, a secondary manual process is needed while creating drill connection holes for the device. This prolongs the process.

20

In conclusion, an improvement is deemed necessary in the respective technical field due to the abovementioned drawbacks and inadequacy of the existing solutions with respect to the subject.

25 **Objects of the Invention**

The present invention relates to a protective cover coating device for medical devices and to the method thereof meeting the abovementioned requirements, eliminating all the disadvantages and introducing some additional advantages.

30

The primary object of the invention is to coat the devices used in the medical areas by means of a device in order to avoid transmission of possible viral and communicable diseases between individuals.

35 An object of the invention is to allow for coating all sorts of devices required to be used in any dental/medical and sterile environment irrespective of their shapes, sizes, functions and

brands by means of the device according to the invention. Making the protective cover of latex and a similar flexible material facilitates coating the devices having various forms.

Another object of the invention is to allow for performing the coating process by means of the device according to the invention without requiring manual manipulation.

Another object of the invention is to allow for removing the protective cover which has been contaminated, from the medical device by means of the device according to the invention without requiring manual manipulation.

10

A similar object of the invention is to shorten the cleaning stage by eliminating or reducing the contaminated surfaces of the medical devices thanks to the protective cover.

The invention aims to avoid creating the hole manually which is required for drill connections after the coating process thanks to the fact that the protective cover is open at both ends.

15

In order to achieve the abovementioned objects, a coating device has been developed which allows for coating the surfaces of the devices and tools that are in direct/indirect contact with the patient in medical and dental areas. Said coating device comprises most basically at least one coating section where the coating process is carried out; an inlet opening which enables the device to be coated to enter into the coating device; at least one sealing ring which provides sealing in the coating section, is located on said inlet opening and has a geometry compatible with the coating section; a power source which provides energy for the coating device; a pump which is activated by the energy it receives from said power source; a valve which controls the entry-exit of a substance while providing negative pressure to the coating section; a connecting end which enables the coating section to be opened to said pump and valve; a connector which connects said pump, valve and connecting end; a protective cover which is placed into the coating section and has a flexible structure; and a carrier ring which fixes the protective cover onto the coating device.

20
25
30

In order to achieve the objects of the invention, a coating method has been developed for coating the surfaces of the devices and tools that are in direct/indirect contact with the patient in medical and dental areas by means of said coating device. This method comprises the process steps of locating the protective cover connected to the carrier ring onto the sealing ring on the coating device; generating negative pressure inside the coating section by activating the pump thanks to the energy received from the power source; inflating and enlarging of the protective cover placed inside the coating section (1) with the effect of the

35

negative pressure; placing the medical/dental device to be coated into the protective cover which has been inflated and enlarged and taken the form of the coating section through the inlet opening; and winding the medical/dental device with the protective cover by releasing the negative pressure as a result of stopping the power source.

5

In order to achieve the objects of the invention, a method for removing the protective cover from the surfaces of the devices and tools which are in direct/indirect contact with the patient in medical and dental areas and has been coated by means of the coating device has been developed. This method comprises the process steps of locating the coated dental/medical
10 device into the coating section through the inlet opening; generating negative pressure inside the coating section by activating the pump by the energy received from the power source; inflating and enlarging of the protective cover on the coated medical/dental device placed inside the coating section with the effect of the negative pressure; removing the protective cover which has been inflated and enlarged and taken the form of the coating section from
15 the medical/dental device.

The structural and characteristic features and all the advantages of the invention will be understood more clearly thanks to the figures given below and the detailed description composed with reference to these figures; and therefore, the evaluation needs to be done by
20 taking into consideration these figures and the detailed description.

Figures to Facilitate Understanding of the Invention

Figure-1a represents a lateral perspective view of the coating device according to the
25 invention.

Figure-1b represents another lateral perspective view of the coating device according to the invention.

Figure-1c represents a cross-sectional view of the coating device according to the invention.

Figure-2a represents a disassembled alternative embodiment of the protective cover to be
30 used for coating the medical/dental devices comprising drill or connection apparatus.

Figure-2b represents an alternative view of the components located on the protective cover to be used for coating the medical/dental devices comprising drill or connection apparatus.

Figure-2c represents an alternative embodiment of the protective cover to be used for coating the medical/dental devices comprising drill or connection apparatus.

35 Figure-3a represents a disassembled view of the protective cover with one end thereof closed which is an alternative embodiment.

Figure-3b represents a view of the protective cover with one end thereof closed which is an alternative embodiment.

Figure-4a represents a disassembled view of the protective cover and the supplementary cover with one end thereof closed which is an alternative embodiment.

5 Figure-4b represents a view of the protective cover and the supplementary cover with one end thereof closed which is an alternative embodiment.

Figure-5a represents an alternative embodiment wherein the coating device of the invention is used to remove the protective cover from the coated medical/dental devices.

10 Figure-5b represents a top view of the barrier used in an alternative embodiment wherein it is used to remove the protective cover from the coated medical/dental devices.

Figure-5c represents a bottom view of the barrier used in an alternative embodiment wherein it is used to remove the protective cover from the coated medical/dental devices.

Figure-6a represents a disassembled view of the adjustable ring.

Figure-6b represents a view of the adjustable ring in an open position.

15 Figure-6c represents a view of the adjustable ring in a closed position.

Figure-7 represents a view of the adjustable ring placed on the glove in a closed position.

Figure-8 represents a view of the adjustable ring placed on the glove in an open position.

20 The drawings do not need to be scaled necessarily and the details that are not necessary for the understanding of the present invention may have been ignored. Apart from this, the elements that are at least substantially identical or that have at least substantially identical functions are shown with the same numbers.

Description of Part References

25

A. Coating device

1. Coating section

2. Inlet opening

3. Sealing ring

30 4. Coating section connection piece

5. Pump

6. Valve

7. Sensor

8. Connecting end

35 9. Connector

10. Valve hose

11. Button

- 12. Carrier ring
- 13. Gripping element
- 14. Fixed connection member
- 15. Mobile connection member
- 5 16. Protective cover
- 17. Open end
- 18. Stopper end
- 19. Stopper
- 20. Opening
- 10 21. Disc
- 22. Plug
- 23. Handle
- 24. Direction indicator
- 25. Supplementary cover
- 15 26. Supplementary cover ring
- 27. Supplementary cover open end
- 29. Closed end
- 30. Supplementary cover inlet opening
- 32. Barrier
- 20 33. Cap
- 34. Cap connection section
- 35. Power source
- 36. Coating section window
- 37. Pipe
- 25 38. Parabolic apparatus
- 39. Gripping section
- 40. Narrow section
- 41. Sphere
- 42. Glove
- 30 43. Wrist part
- 44. Adjustable ring

Detailed Description of the Invention

- 35 In this detailed description, preferred embodiments of the protective cover (16) coating device (A) according to the invention are described only for a better understanding of the invention without any limiting effect.

The invention is related to a protective cover (16) coating device (A) that is used to coat the devices such as medical/dental devices or a tattoo gun which need to be hygienic and carry a risk of transmitting diseases from person to person. Furthermore, the coating device (A) can also be used to wear the gloves which can be considered as a protective cover especially in a surgical environment without using hands. Said coating device (A) can also be used to coat the probes of ultrasound devices (biplanar, intra-rectal, vaginal, convex, and linear probes), endoscopic cameras, and laparoscopic cameras.

Perspective views from both sides of the coating device (A) according to the invention are given in Figures 1a and 1b. On the other hand, a cross-sectional view of the coating device (A) is given in Figure 1c wherein internal parts thereof can be seen. As seen in the figure, the coating device (A) comprises at least one coating section (1) where the coating process will be carried out. Said coating section (1) is configured such that one side thereof will be open and the other side thereof will be closed. A sealing ring (3) which encircles the inlet opening (2) on the coating section (1) and provides sealing of the negative pressure generated inside the coating section is provided. Said sealing ring (3) is made of silicon material. The coating section (1) and the sealing ring (3) encircling the coating section (1) can be cylindrical or can have a different geometric form. The coating section (1) can be tetragonal prism, rectangular prism, triangular prism, elliptical, conical or reverse conical in shape or can be a combination of several geometric forms. Moreover, sizes of the coating section (1) can be changed depending on the size and shape of the device to be coated or more than one coating section (1) can be provided in one coating device (A). In conclusion, the inner diameter of the coating section (1) and the sealing rings (3) should be larger enough to incorporate several devices and tools. A coating section connection piece (4) is provided on the closed end of the coating section (1). Said connection piece (4) is connected with the pump (5) and the valve (6).

At least one pump (5) and valve (6) are contained for the negative pressure to be generated in the coating section (1). Said pump (5) discharges the air inside the coating area (1) and enables the protective cover (16) placed on the sealing ring (3) to expand inwards and inflate. Besides, said pump (5) is a vacuum or liquid pump. The valve (6), on the other hand, is responsible for entry and exit of the substance (air or liquid) used in the process that is carried out to generate negative pressure. Said valve (6) is a solenoid liquid or solenoid air valve.

In addition, the coating device (A) of the invention comprises a power source (35) to be activated. In the invention, the preferred power source is a cell battery. However; if preferred,

the coating device (A) can also be activated by utilizing an external absorbing power without incorporating any electronic component and pump (5). To that end, a vacuum effect from the outside that will be connected to the connecting end (8) of the coating section (1) will be enough. Devices capable of vacuuming such as a surgical aspirator available in dental
5 offices can be used to create a vacuum effect. The coating device (A) can be portable or it can be used as one-piece on the dental chair.

Additionally, the coating device (A) comprises some components which are employed for connecting the coating section (1), pump (5), and valve (6) to each other and allow for
10 carrying the substance (air or liquid) that generates the negative pressure. A connecting end (8) which connects the pump (5) to the coating section (1) is provided. Besides, a connector (9) which connects the pump (5), valve (6) and connecting end (8) is contained. Said connector (9) is a T-connector. In addition, a valve hose (10) which connects said valve (6) to the connector (9) is included.

15 Additionally, a sensor (7) is preferably provided on the coating device (A). Said sensor (7) is situated towards the closed end of the coating section (1) and checks if the protective cover (16) reaches the base or not. When the sensor (7) detects that the protective cover (16) has reached the base, it stops the pump (5). Said sensor (7) is an infrared proximity sensor. The
20 sensor (7) which is used to check the termination of the negative pressure can be inside or outside the coating section (1). A mechanical switch placed to the base or lateral surface inside the coating section (1) can also provide the same function instead of the sensor (7).

Besides, a coating section window (36) is preferably provided on the coating device (A). It is
25 a section that is formed to observe the protective cover (16) inside the coating section (1).

A button (11) is provided on the coating device (A). Said button (11) allows for starting and ending the vacuuming by checking the pump (5), valve (6) and sensor (7).

30 The component which will be used in the coating process inside the coating device (A) is a protective cover (16). The protective cover (16) is made of an elastic material such as latex and nitrile. Raw material of nitrile covers is acrylonitrile butadiene which is a synthetic copolymer; and as it does not contain latex, it can be used as an alternative for those who are allergic to latex.

35 It is important to design the inner diameter of the protective cover (16) smaller than that of the dental and medical devices to be coated in order to cover the surfaces of the devices

more tightly and to avoid any debris and liquid entry between the surfaces of the coated device. Therefore, diameter of the protective cover (16) should be 5-6 mm at the most.

5 The protective cover (16) placed on the sealing ring (3) encloses the open inlet opening (2) of the coating section (1) hermetically. The protective cover (16) is placed on the sealing ring (3) by means of a carrier ring (12). The carrier ring (12) is connected to the open end (17) of the protective cover (16). Said ring can preferably comprise a gripping element (13). The gripping element (13) allows for retaining the carrier ring (12) and removing thereof from the protective cover (16) after the coating process. Said carrier ring (12) can be made of a rigid
10 material or of a more flexible material such as silicon and rubber.

The gripping element (13) is connected onto the carrier ring (12) such that it will make a 90-degree angle by means of a mobile connection member (15) and a fixed connection member (14). Since the gripping element (13) is connected to the carrier ring (12) by means of a
15 mobile connection member (15), it can be moved for 180° in the reverse direction of the center of the carrier ring (12). Thanks to this movement, the protective cover (16) on the flat surface of the gripping element (13) can be pushed outside the carrier ring (12) and the carrier ring (12) can be removed easily after the coating process.

20 A preferred embodiment of the protective cover (16) is illustrated in Figure 2a. In the figure, the protective cover (16) is chosen such that both ends thereof will be open. Thus, it is ensured that the device is coated such that there will be an open surface just as large as the drill or apparatus inlet opening.

25 In said embodiment, a gripping element (13) and a carrier member (12) are provided on the open end (17) of the protective cover (16). Said carrier ring (12) comprises a gripping element (13). A stopper end (18) is provided on the other end of the protective cover (16). The stopper (19) is provided which is connected to the stopper end (18) providing hermetical sealing and has a diameter larger than that of the stopper end (18).
30

An opening (20) is created at the center of the stopper (19) for drill or apparatus connection of the dental/medical devices. A complete closed structure is obtained by inserting a plug (22) into said opening (20) with a diameter that is compatible with that of the opening, wherein said plug has a handle (23) thereon.
35

Besides, a sponge disc (21) soaked into disinfectant is provided on the surface of the stopper (19) which remains inside the protective cover (16). Said disc (21) is integrated with the

stopper (19). The sponge disc (21) soaked into disinfectant supports disinfection by contacting directly with the drill or apparatus connection surface of the device after the coating process. In addition, a direction indicator (24) which indicates the direction of placing the protective cover (16) into the coating device (A) is provided on the plug (22) with a handle (23).

Figure 2b illustrates a preferred embodiment of the components which are connected to said protective cover (16). The stopper (19) can be produced and used as integrated with the plug (22) and the handle (23) without an opening (20) thereon. In such case, the stopper (19) is completely removed from the stopper end (18) of the protective cover (16) by means of the handle (23) after the coating process. Said disc (21) is also provided in this preferred embodiment in order to provide disinfecting property.

Figure 2c illustrates an alternative embodiment wherein the characteristics mentioned in Figures 2a and 2b are employed together. In addition to said characteristics, a section which is created by curling the protective cover (16) over itself at the stopper end (18) in order to prevent the stopper (19) from being separated from the protective cover (16). Besides, the open end (17) of the protective cover (16) inserted into the carrier ring (12) is provided on the flat surface that is formed by making a 90-degree angle between gripping element (13) and the carrier ring (12).

Figure 3a illustrates another alternative embodiment of the protective cover (16). Said protective cover (16) is designed such that only one end thereof is open. Thus, it is used to coat devices which does not contain drill or apparatus connection (light curing device, intra-oral camera, digital x-ray sensor, reflector arm, etc.). Therefore, said protective cover (16) has a closed end (29). As seen in Figure 3b, the open end (17) of the protective cover (16) with a closed end (29) is inserted into the carrier ring (12). As mentioned before, the carrier ring (12) can also comprise a gripping element (13) if preferred (not shown in the figures).

Figure 4a illustrates another alternative embodiment of the protective cover (16). When some dental/medical devices are considered, the inner diameter of the coating section (1) and the sealing ring (2) restricts the devices and tools to be coated. A supplementary cover (25) is provided to coat the dental/medical devices which are larger than the inner diameter. The supplementary cover (25) is connected with the carrier ring (12). Said supplementary cover (25) has a structure with both ends thereof being open. The supplementary cover open end (27) is provided in the section where said supplementary cover is connected with the carrier ring. A supplementary cover inlet end (30) of the supplementary cover (25) is provided at the

other end of the supplementary cover (25) and the supplementary cover ring (26) is integrated with the supplementary cover (25) at this end.

5 The supplementary cover open end (27) can be combined and used with the protective cover (16). In this manner, the parts of dental/medical devices which do not fit into the coating device (A) can be coated by means of the supplementary cover (25).

10 The use of protective cover (16) together with the supplementary cover (25) is illustrated in Figure 4b. The carrier ring (12) which is compatible with the geometry and diameter of the supplementary cover ring (26) that is made of a rigid or semi-rigid material is placed such that it will be inside the supplementary cover (25) on the side of the supplementary cover open end (27). A combination of the protective cover (16) and the supplementary cover (25) is obtained by inserting a protective cover (16) into the carrier ring (12). Then, the supplementary cover (25) is brought together inside the supplementary cover ring (26) and the supplementary cover ring (26) is inserted onto the carrier ring (12).

20 For the medical/dental devices such as light curing devices and wireless endodontic micromotors hand-held parts of which are large, the parts which enter into the coating section (1) are coated with the protective cover (16) while the parts which are larger than the inner diameter of the coating section (1) and the sealing ring (3) are coated with the supplementary cover (25).

25 In said supplementary cover (25)-protective cover (16) combination, the protective cover (16) with one end thereof closed as in Figure 3b can be employed if there is not any drill and apparatus connection, and the embodiments as in Figure 2a and 2c can be employed if there is a drill and apparatus connection.

Operating principle:

30 Before operating the coating device (A), the protective cover (16) (with one end or both ends thereof open or in combination with the supplementary cover (25)) should be selected based on the shape of the dental/medical device to be coated. Afterwards, the protective cover (16) is connected with the carrier ring (12). Then, the carrier ring (12) connected with the protective cover (16) is inserted onto the sealing ring (3) on the coating section (1). Thus, the inlet opening (2) of the coating section (1) is hermetically closed.

When the on-off button (11) is pressed, the solenoid air valve (6) hinders the air intake and the vacuum pump (5) starts to suck air from the coating section (1) to which it is connected.

5 As soon as the activated pump (5) starts to discharge air from the coating section (1), a negative pressure occurs inside the coating section (1). Thanks to the generated negative pressure, the protective cover (16) enlarges and starts to inflate inside the coating section (1).

10 When the protective cover (16) which moves forward inside the coating section (1) reaches the bottom of the coating section (1), it triggers the infrared proximity sensor (7). The activated proximity sensor (7) stops the vacuum pump (5) and warns the user audibly and visually. This prevents the vacuum pump (5) from operating for a long time and provides energy saving. Afterwards, the device or tool to be coated is placed into the latex protective cover (16) that has been enlarged through the inlet opening (2) of the coating section (1).

15

After this process step, the button (11) is pressed again and the solenoid air valve (6) and the vacuum pump (5) are completely deactivated; and as a result, air is let into the coating section (1). The protective cover (16) which has been inflated due to the pressure change inside the coating section (1) starts to shrink and encircle the device placed therein tightly.
20 The device inside the coating section (1) is removed from the device as covered with the protective cover (16).

The carrier ring (12) with or without a gripping element (13) can be removed from the protective cover (16) or left thereon optionally and depending on the area of use of the coated device. If the carrier ring (12) has a gripping element (13), the carrier ring (12) can be easily removed by pulling from the gripping element (13). Thanks to the movement of the mobile connection member (15) of the gripping element (13) that is connected to the carrier ring (12), it can be moved for 180° in the reverse direction of the center of the carrier ring (12). Thanks to this movement, the protective cover (16) on the fixed connection member (14) of the gripping element can be pushed outside the carrier ring (12) and the carrier ring (12) can be easily removed from the protective cover (16). If the coated device has a drill or apparatus connection, the plug (22) with a handle (23) at the stopper end (18) of the protective cover (16) is removed from the protective cover (16). Besides, the opening (20) of the stopper (19) is adjusted by being centered such that it will correspond to the drill or apparatus connection hole of the coated device. In this manner, a surface only as large as
35 the drill or apparatus inlet space of the coated device will be left open and the stopper (19)

with an opening (20) will be located on the coated device and under the protective cover (16).

Removal of the device coated with the protective cover (16) after use:

5

In order to remove the protective cover (16) seen in Figure 2a and 2c which is used especially for the devices with a drill and apparatus hole, the open end (17) of the protective cover (16) on the coated device is forwarded by being manually rolled towards the stopper end (18) of the protective cover (16) and removed from the coated device.

10

In order to remove the protective covers (16) as in Figure 3b and 4b, the coated material needs to be placed into the coating section (1) through the inlet opening (2) of the coating device (A) and the device needs to be activated. The protective cover (16) on the coated material enlarges and inflates inside the coating section (1) with the effect of negative pressure. Thus, the protective cover (16) is separated from the coated device. The user finishes the process by taking the device that is released in the inflated protective cover (16) outside the coating section (1).

15

The use of two separate devices for the process of coating and removing the protective cover (16) is important in the control of cross-infection. For this reason, it is highly important to make available two separate devices and not to confuse one with the other in practice.

20

Figure 5a illustrates an alternative embodiment of the device (A) to be used in the process of removing the protective cover (16). A barrier (32) hindering the inlet is provided in the inlet opening (2) of the coating section (1) instead of the sealing ring (3).

25

Figures 5b and 5c illustrate top and bottom views of said barrier (32) respectively. Said barrier (32) is triangular in shape and made of silicon and it consists of caps (33). The cap connection area (34) which is the large side of these triangular caps (33) is combined with the inner surface of the barrier (32). Said caps (33) have an elastic and mobile structure so as to let only the coated medical/dental device enter into the coating section (1). Thus, the use of the device (A) with a barrier (32) attached thereto in the process of coating protective cover (16) by the user is avoided both physically and visually.

30

35

Use of the coating device (A) for the process of wearing a glove without contact:

It is quite important to check the medical gloves whether they are pierced or not before and after use. Required measures should be taken according to the area and risk of use of the person using the glove which is detected as pierced after use.

The coating device (A) of the invention can be used to wear the medical gloves. It can be used to wear and take off the gloves (42) by designing the gloves (42), which have the inlet opening (2) of the coating device (A) and sealing ring (3) designs as shown in Figure 6b, with a diameter and geometry compatible with the open position of the adjustable ring (44).

The adjustable ring (44) which will be attached to the wrist part (43) of the medical gloves (42) is shown in Figures 6a, 6b and 6c. The adjustable ring (44) consists of a pipe (37) made of parabolic polyurethane material suitable for the wrist anatomy of a human being and a parabolic apparatus (38) moving inside said pipe (37). The parabolic apparatus (38) can be made of plastic or metal material.

The adjustable ring (44) is shown in two positions as open and closed in Figures 6b and 6c respectively. The diameter of the parabolic apparatus (38) is smaller than the inner diameter of the pipe (37). Thus, the parabolic apparatus (38) can easily move inside the pipe (37). In order for the adjustable ring (44) to stay in the open position inside the medical glove (42), spheres (41) are provided at both end of the parabolic apparatus (38). The diameter of these spheres (41) is smaller than the inner diameter of the pipe (37) and larger than the narrow parts (40) at the ends of the pipe (37). As such, when the parabolic apparatus (38) easily moves inside the pipe (37) and the spheres (41) at the end of the apparatus (38) reach the narrow part (40) at the end of the hose, the spheres(41) get stuck in this section and enable the adjustable ring (44) to stay in the open position.

There is a gripping section (39) on the parabolic apparatus (38) of the adjustable ring (44). As seen in Figure 6c, said gripping section (39) ensures integrity of the pipe (37) in the closed position of the adjustable ring (38). Besides, it makes it easy to hold the gripping section (39) while the adjustable ring (44) is being brought to the open position. The gripping section (39) of the adjustable ring (44) is adjusted to the wrist part (43) of the medical glove (42) such that it will be on the side of the thumb of the glove (42). Thus, the adjustable ring (44) can be easily opened and closed manually before and after use.

The closed position of adjustable ring (44) that is attached to the wrist part (43) of the medical glove (42) is seen in Figure 7 while the open position thereof is seen in Figure 8.

The use of different coating devices (A) while wearing and taking off the medical gloves (42)
5 is important in terms of sterilization.

CLAIMS

1. A coating device (A) allowing for coating the surfaces of the devices and tools that are in direct/indirect contact with the patient in medical and dental areas, characterized in comprising
- at least one coating section (1) where the coating process is carried out,
 - an inlet opening (2) which enables the device to be coated to enter into the coating device (A),
 - at least one sealing ring (3) which provides sealing in the coating section (1), is located on said inlet opening (2) and has a geometry compatible with the coating section (1),
 - a power source (35) which provides energy for the coating device (A),
 - a pump (5) which is activated thanks to the energy it receives from said power source (35),
 - a valve (6) which controls the entry-exit of a substance while providing negative pressure to the coating section (1),
 - a connecting end (8) which enables the coating section (1) to be opened to said pump (5) and valve (6),
 - a connector (9) which connects said pump (5), valve (6) and connecting end (8),
 - a protective cover (16) which is placed into the coating section (1) and has a flexible structure, and
 - a carrier ring (12) which fixes the protective cover (16) onto the coating device (A).
2. The coating device (A) as in Claim 1, characterized in comprising an infrared proximity sensor (7) or a mechanical switch which controls the enlargement of the protective cover (16) with the effect of the negative pressure.
3. The coating device (A) as in Claim 1, characterized in comprising a valve hose (10) which connects said valve (6) to the connector (9).
4. The coating device (A) as in Claim 1, characterized in comprising a button (11) which turns on/off said coating device (A).
5. The coating device (A) as in Claim 1, characterized in that said carrier ring (12) comprises a gripping element (13).

6. The coating device (A) as in Claim 4, characterized in that said gripping element (13) comprises a fixed connection member (14) and a mobile connection member (15).

5 7. The coating device (A) as in Claim 1, characterized in that said protective cover (16) is latex or nitrile.

8. The coating device (A) as in Claim 1, characterized in that said protective cover (16) comprises an open end (17) and a stopper end (18) in order to be used in medical/dental devices with drill or connection apparatus.

10 9. The coating device (A) as in Claim 8, characterized in that a stopper (19) connected to the stopper end (18) of said protective cover (16) is provided.

15 10. The coating device (A) as in Claim 9, characterized in comprising an opening (20) on said stopper (19).

11. The coating device (A) as in Claim 9 or 10, characterized in comprising a sponge disc (21) which is soaked into disinfectant and integrated with said stopper (19).

20 12. The coating device (A) as in Claims 9, 10 or 11, characterized in comprising a plug (22) and a handle (23) connected to said stopper (19).

13. The coating device (A) as in Claim 12, characterized in comprising a direction indicator (24) connected to said plug (22) and handle (23).

25 14. The coating device (A) as in Claim 1, characterized in that said protective cover (16) comprises an open end (17) and a closed end (29) in order to be used in medical/dental devices without drill or connection apparatus.

30 15. The coating device (A) as in Claim 14, characterized in comprising a supplementary cover (25) which is connected to said protective cover (16) by means of the carrier ring (12).

35 16. The coating device (A) as in Claim 15, characterized in that said supplementary cover (25) comprises a supplementary cover open end (27) and a supplementary cover inlet end (30).

17. The coating device (A) as in Claim 16, characterized in that said supplementary cover (25) comprises a supplementary cover ring (26) at the supplementary cover inlet end (30).

18. The coating device (A) as in Claim 1, characterized in comprising a barrier (32) when said coating device (A) is used to remove the coated protective covers.
19. The coating device (A) as in Claim 18, characterized in that said barrier (32) comprises caps (33).
5
20. The coating device (A) as in Claim 1, characterized in that said protective cover (16) is a glove (42).
- 10 21. The coating device (A) as in Claim 20, characterized in that said glove (42) comprises an adjustable ring (44) thereon.
22. The coating device (A) as in Claim 21, characterized in comprising a pipe (37), a parabolic apparatus (38), a gripping section (39), a narrow section (40) and a sphere (41) on
15 said adjustable ring (44).
23. The coating device (A) as in Claim 1, characterized in comprising a coating section window (36) through which the coating section (1) can be seen.
- 20 24. A method for coating the surfaces of the devices and tools that are in direct/indirect contact with the patient in medical and dental areas by means of said coating device (A) as in Claim 1, characterized in comprising the following process steps;
- locating the protective cover (16) connected to the carrier ring (12) onto the sealing ring (3) on the coating device (A);
 - 25 – generating negative pressure inside the coating section (1) by activating the pump (5) thanks to the energy received from the power source (35);
 - inflating and enlarging of the protective cover (16) placed inside the coating section (1) with the effect of the negative pressure;
 - placing the medical/dental device to be coated into the protective cover (16) which
30 has been inflated and enlarged and taken the form of the coating section (1) through the inlet opening (2); and
 - winding the medical/dental device with the protective cover (16) by releasing the negative pressure as a result of stopping the power source (35).
- 35 25. A method for removing the protective cover (16) from the surfaces of the devices and tools which are in direct/indirect contact with the patient in medical and dental areas and has been coated by means of said coating device (A) as in Claim 1, characterized in comprising the following process steps;

- locating the coated dental/medical device into the coating section (1) through the inlet opening (2);
 - generating negative pressure inside the coating section (1) by activating the pump (5) thanks to the energy received from the power source (35);
- 5 – inflating and enlarging of the protective cover (16) on the coated medical/dental device placed inside the coating section (1) with the effect of the negative pressure;
- and removing the protective cover (16) which has been inflated and enlarged and taken the form of the coating section (1) from the medical/dental device.
- 10 **26.** The coating/removing method as in Claim 24 or 25, characterized in that the process step of pressing the button (11) is realized with the energy received from the power source (35).
- 15 **27.** *The coating/removing method as in Claim 24 or 25, characterized in comprising the process step of detecting the inflation and enlargement of the protective cover (16) by means of the sensor (7) on the coating device (A) and of stopping the power source (35) by activating valve (6).*

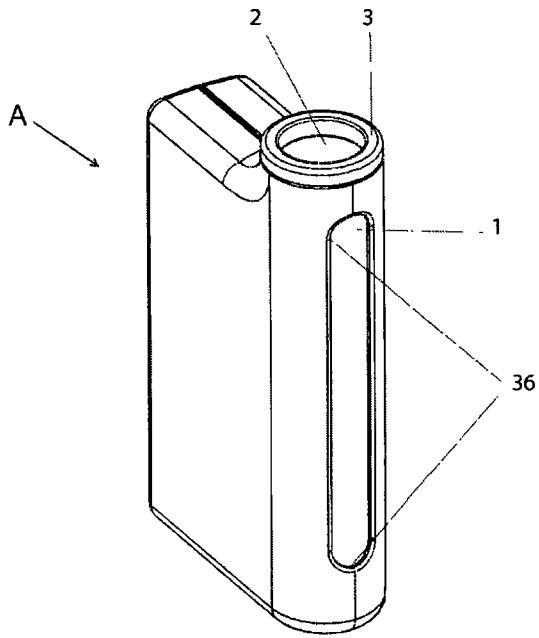

Figure 1a

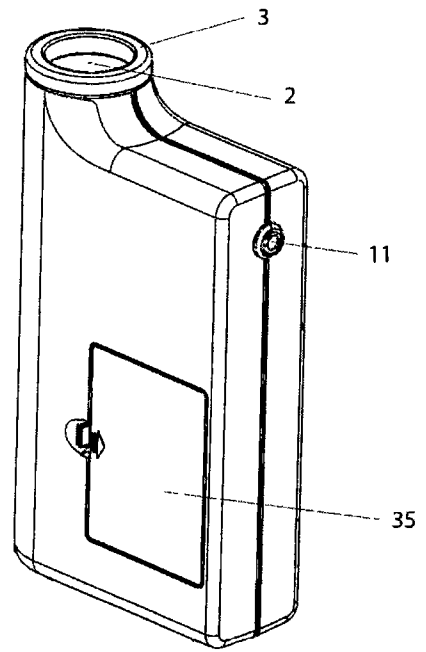

Figure 1b

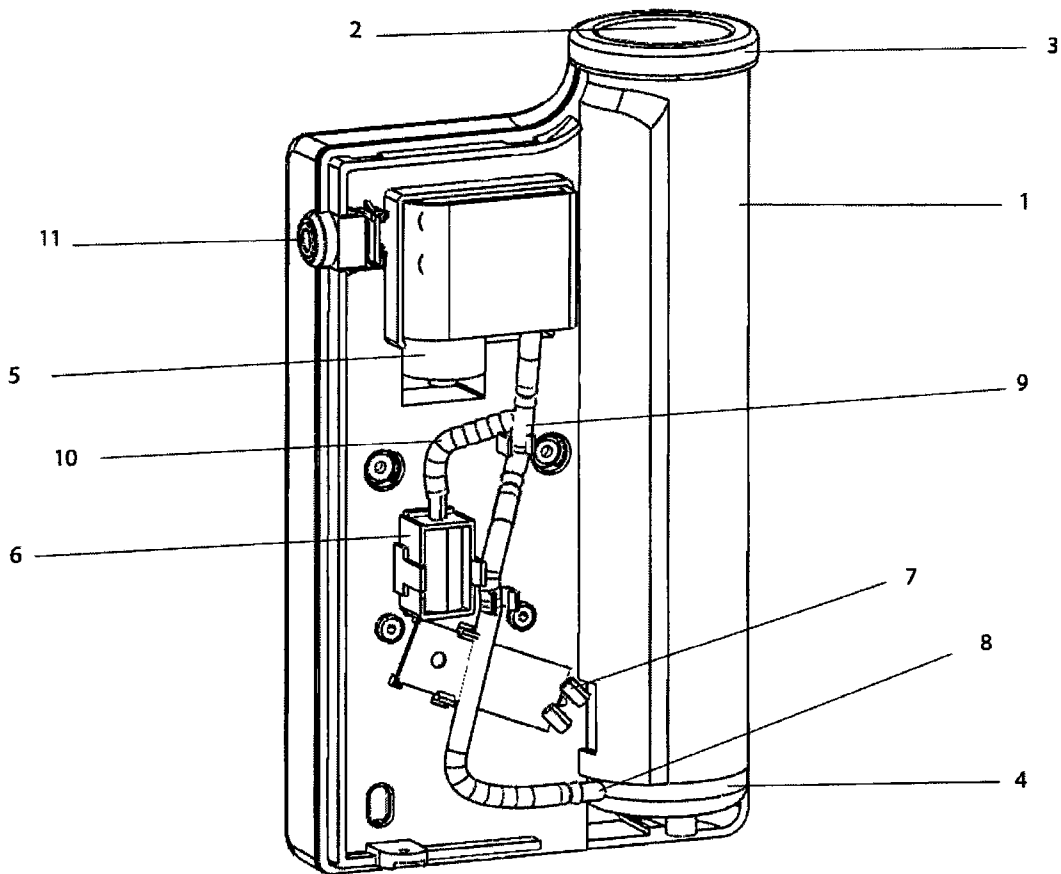

Figure 1c

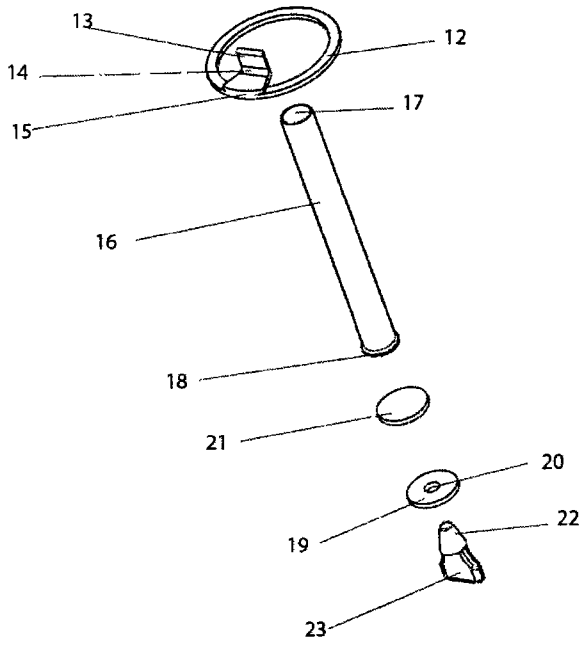

Figure 2a

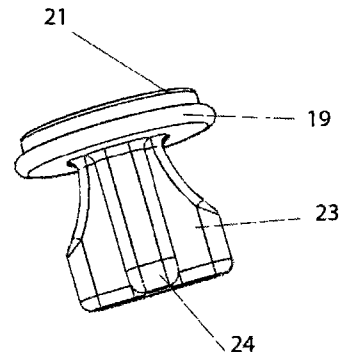

Figure 2b

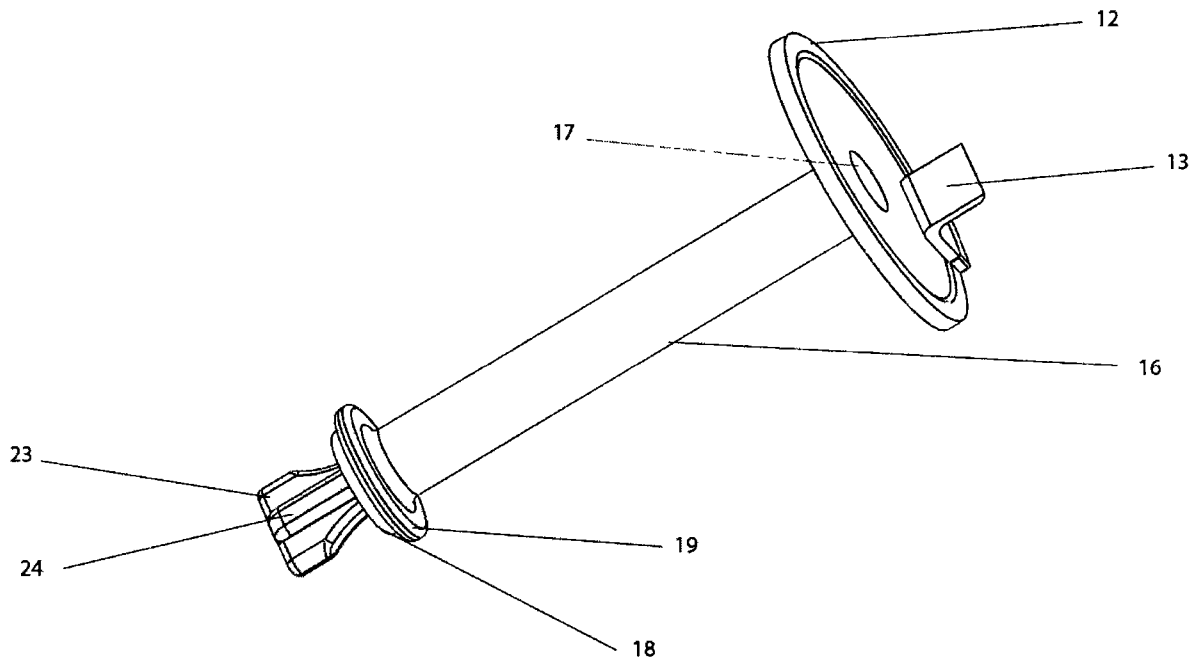

Figure 2c

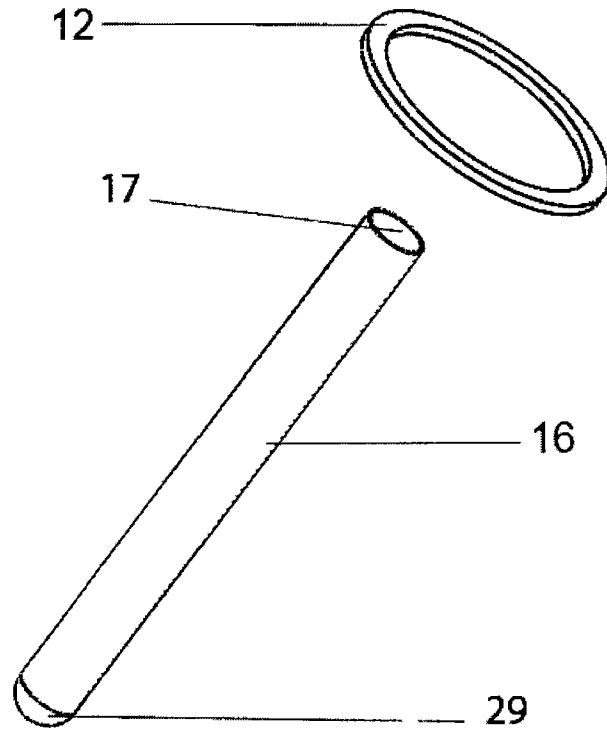

Figure 3a

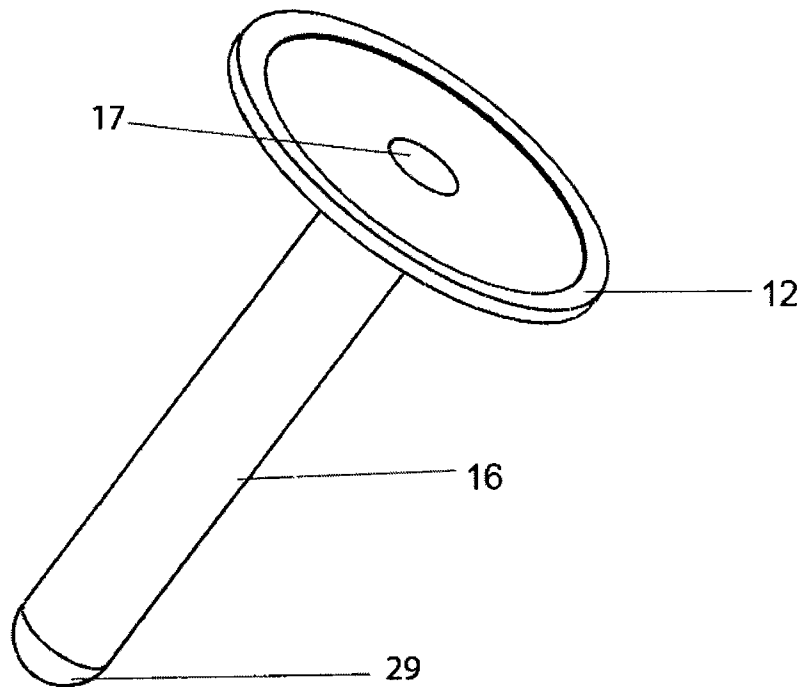

Figure 3b

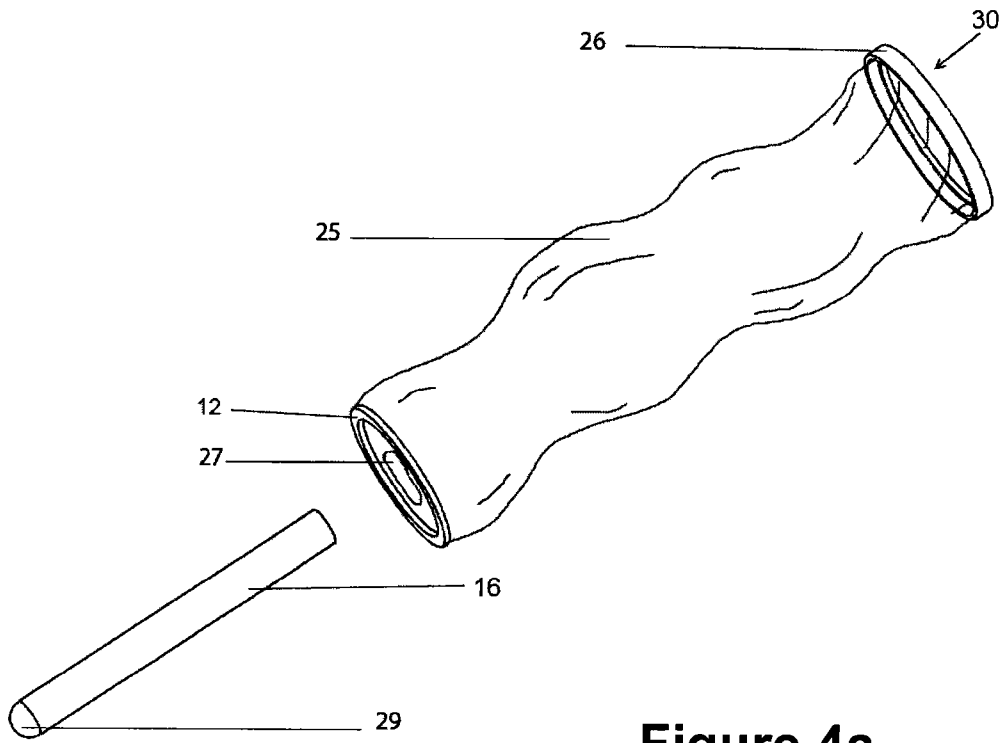

Figure 4a

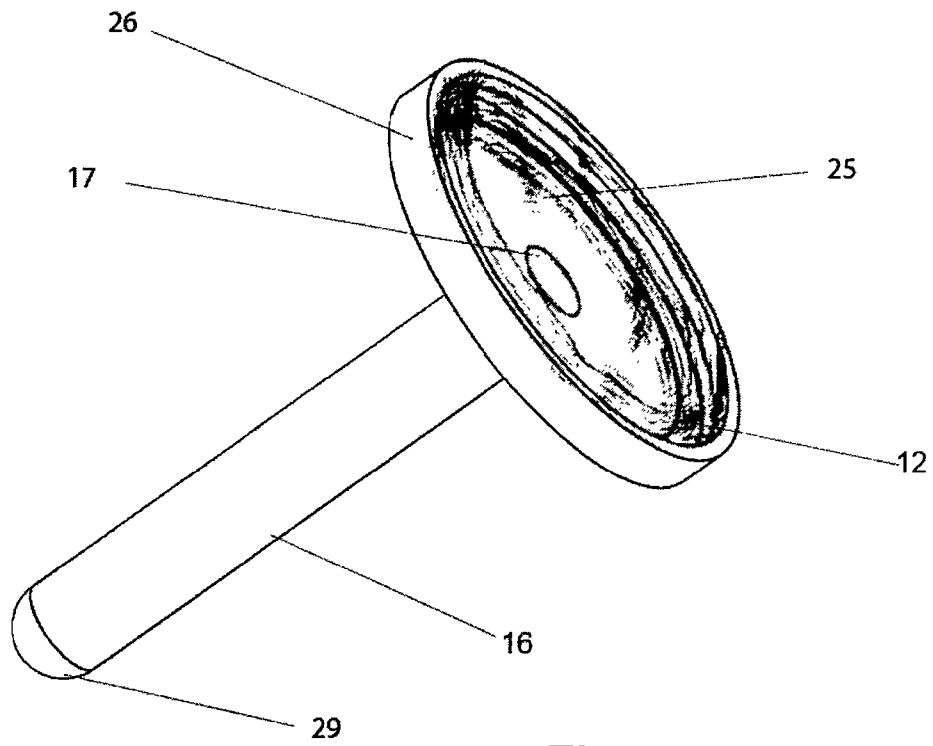

Figure 4b

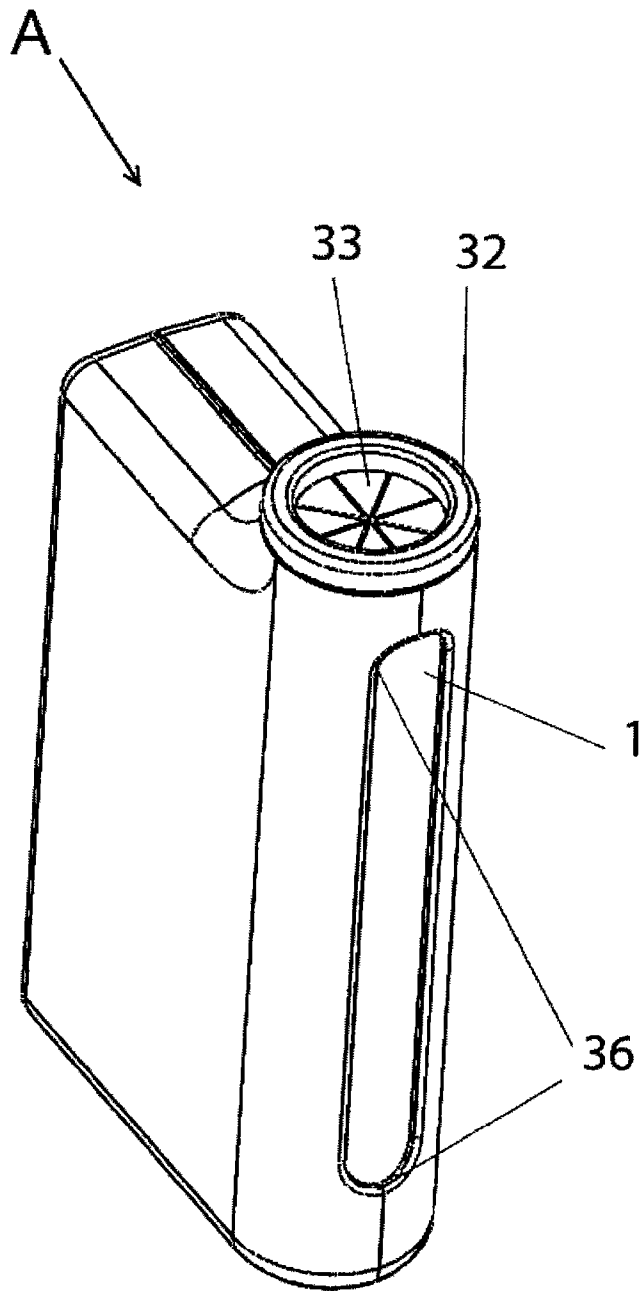

Figure 5a

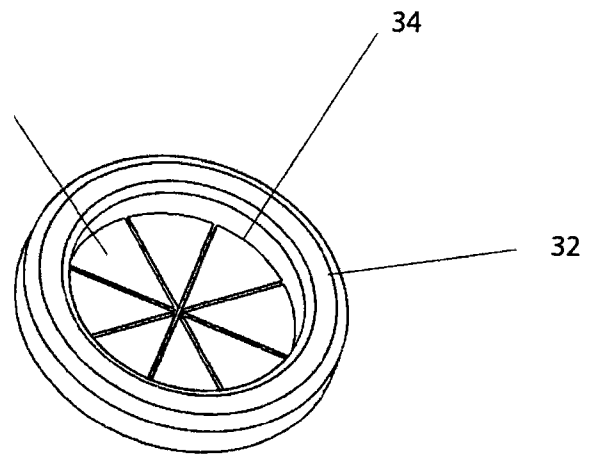

Figure 5b

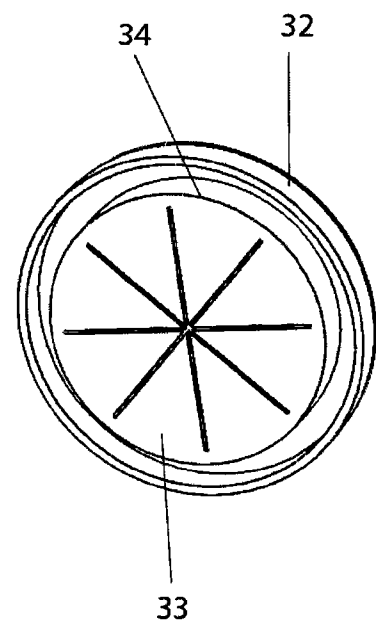

Figure 5c

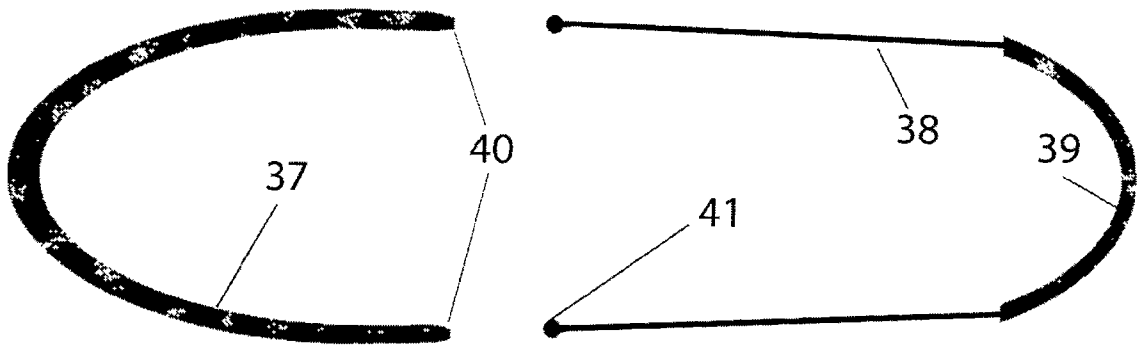

Figure 6a

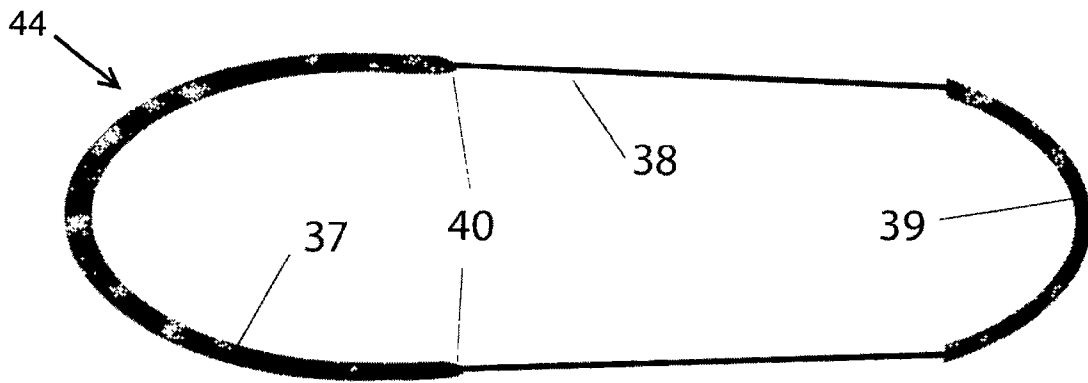

Figure 6b

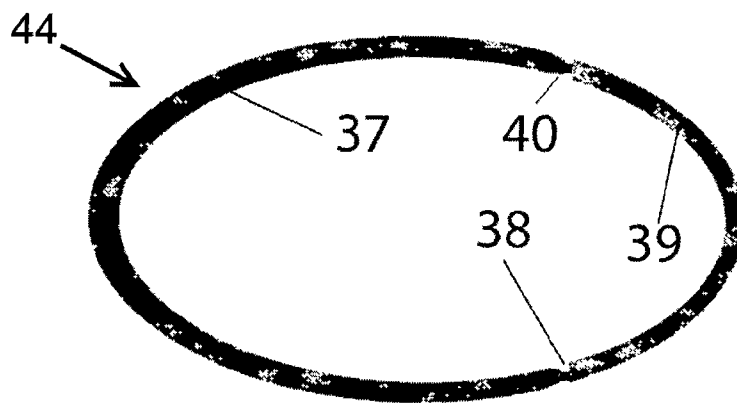

Figure 6c

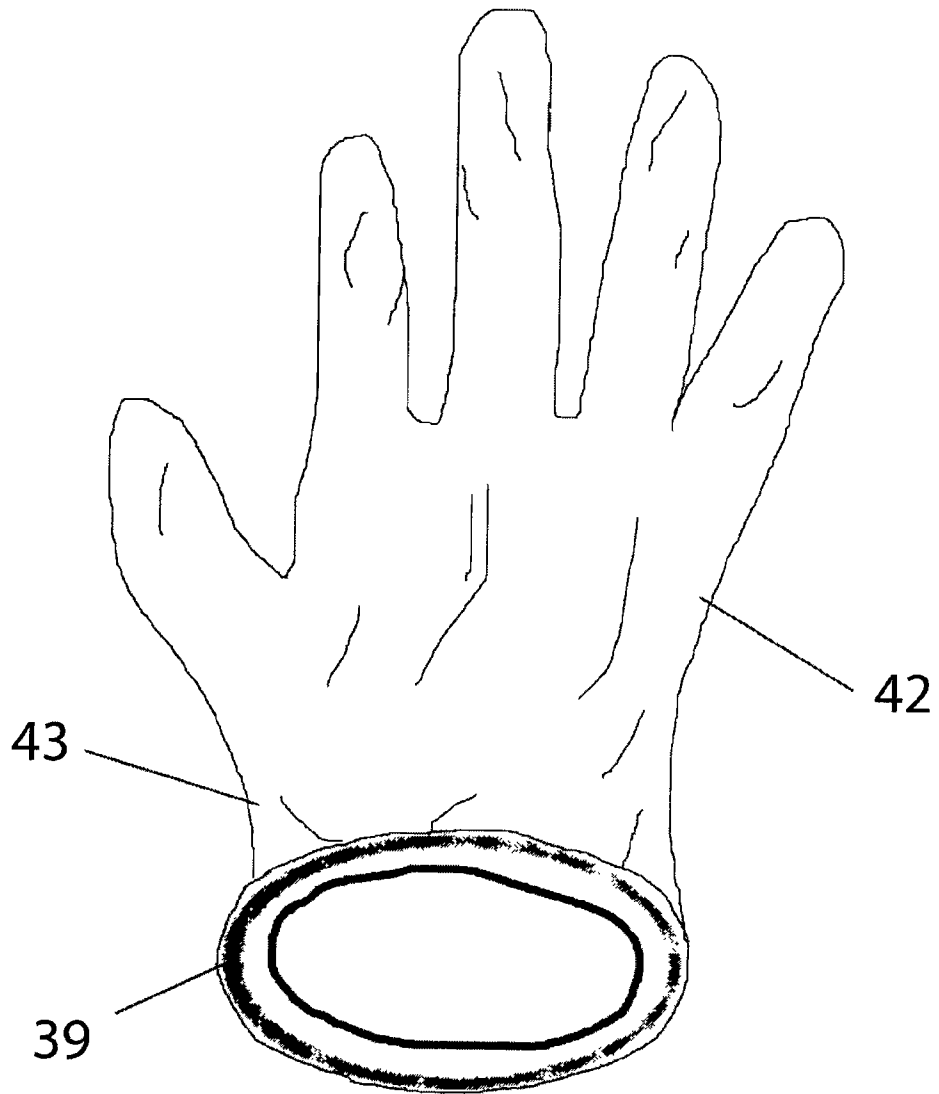

Figure 7

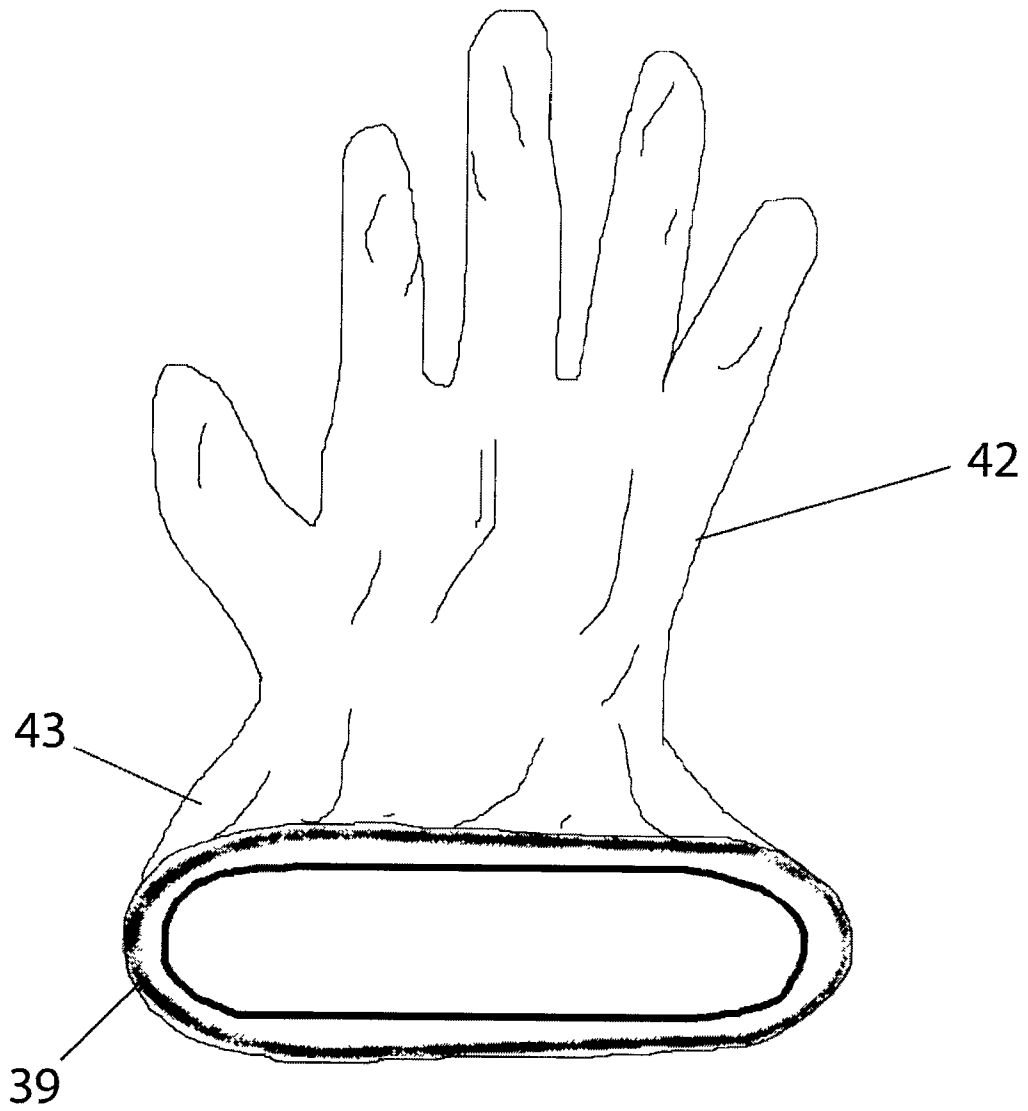

Figure 8

INTERNATIONAL SEARCH REPORT

International application No
PCT/TR2015/000250

A. CLASSIFICATION OF SUBJECT MATTER

INV. A61C1/16 A61B1/00
ADD. B29C55/24 B65B53/00 A61B19/02 A61B19/04

According to International Patent Classification (IPC) or to both national classification and IPC

B. FIELDS SEARCHED

Minimum documentation searched (classification system followed by classification symbols)

A61C A61B B29C B65B B65D

Documentation searched other than minimum documentation to the extent that such documents are included in the fields searched

Electronic data base consulted during the international search (name of data base and, where practicable, search terms used)

EPO-Internal, WPI Data

C. DOCUMENTS CONSIDERED TO BE RELEVANT

Category*	Citation of document, with indication, where appropriate, of the relevant passages	Relevant to claim No.
A	US 5 050 585 A (TAKAHASHI NAGASHIGE [JP]) 24 September 1991 (1991-09-24) column 3, lines 48-50, 57-66 -----	1-19, 23-27
A	US 6 530 881 B1 (AILINGER ROBERT E [US] ET AL) 11 March 2003 (2003-03-11) column 3, lines 30-35, 42-52 -----	1-19, 23-27
Y	US 2008/073388 A1 (SAEGUSA TAKASHI [JP]) 27 March 2008 (2008-03-27) paragraphs [0103], [0107] - [0108]; claims 3, 8, 12 -----	20-22
Y	US 4 002 276 A (PONCY MARK P ET AL) 11 January 1977 (1977-01-11) column 4, lines 28-39 column 5, lines 14-18 column 6, lines 6-19 -----	20-22

Further documents are listed in the continuation of Box C.

See patent family annex.

* Special categories of cited documents :

"A" document defining the general state of the art which is not considered to be of particular relevance
"E" earlier application or patent but published on or after the international filing date
"L" document which may throw doubts on priority claim(s) or which is cited to establish the publication date of another citation or other special reason (as specified)
"O" document referring to an oral disclosure, use, exhibition or other means
"P" document published prior to the international filing date but later than the priority date claimed

"T" later document published after the international filing date or priority date and not in conflict with the application but cited to understand the principle or theory underlying the invention
"X" document of particular relevance; the claimed invention cannot be considered novel or cannot be considered to involve an inventive step when the document is taken alone
"Y" document of particular relevance; the claimed invention cannot be considered to involve an inventive step when the document is combined with one or more other such documents, such combination being obvious to a person skilled in the art
"&" document member of the same patent family

Date of the actual completion of the international search

6 November 2015

Date of mailing of the international search report

16/11/2015

Name and mailing address of the ISA/

European Patent Office, P.B. 5818 Patentlaan 2
NL - 2280 HV Rijswijk
Tel. (+31-70) 340-2040,
Fax: (+31-70) 340-3016

Authorized officer

Bjola, Bogdan

INTERNATIONAL SEARCH REPORT

Information on patent family members

International application No

PCT/TR2015/000250

Patent document cited in search report	A	Publication date	Patent family member(s)	Publication date
US 5050585	A	24-09-1991	DE 3909290 A1	12-10-1989
			JP H0360486 B2	13-09-1991
			JP H01244732 A	29-09-1989
			US 5050585 A	24-09-1991

US 6530881	B1	11-03-2003	AU 5081801 A	05-02-2002
			EP 1581091 A2	05-10-2005
			JP 4800552 B2	26-10-2011
			JP 2004510464 A	08-04-2004
			US 6530881 B1	11-03-2003
			WO 0207787 A2	31-01-2002

US 2008073388	A1	27-03-2008	JP 2008081852 A	10-04-2008
			US 2008073388 A1	27-03-2008
			WO 2008038438 A1	03-04-2008

US 4002276	A	11-01-1977	NONE	
