

C. F. DUKE.  
HACKSAW.

APPLICATION FILED JUNE 24, 1909.

1,000,159.

Patented Aug. 8, 1911.

2 SHEETS—SHEET 1.

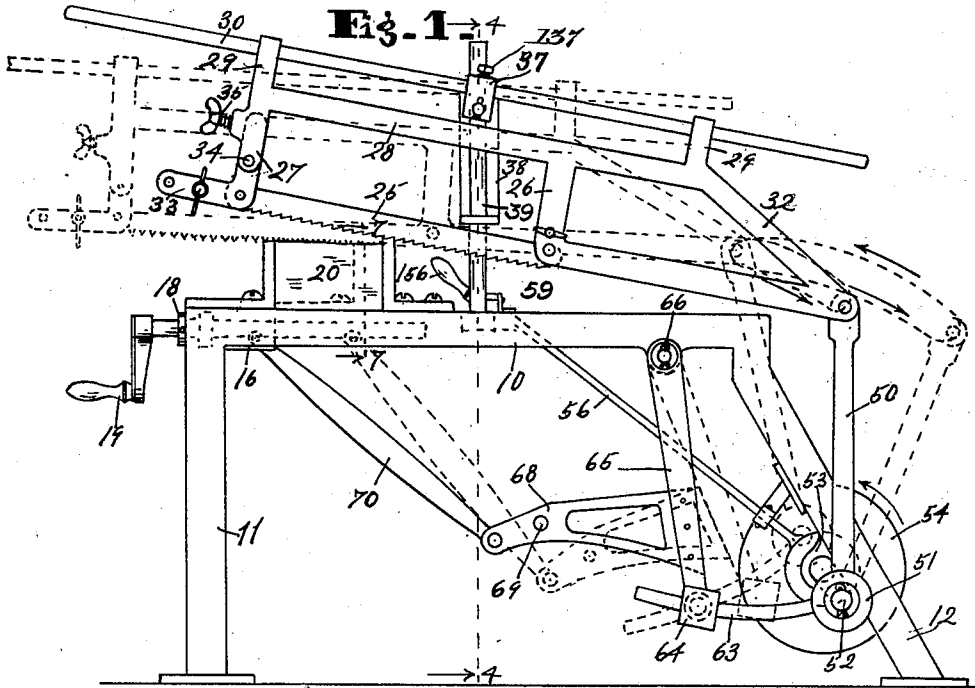

Fig. 2 -

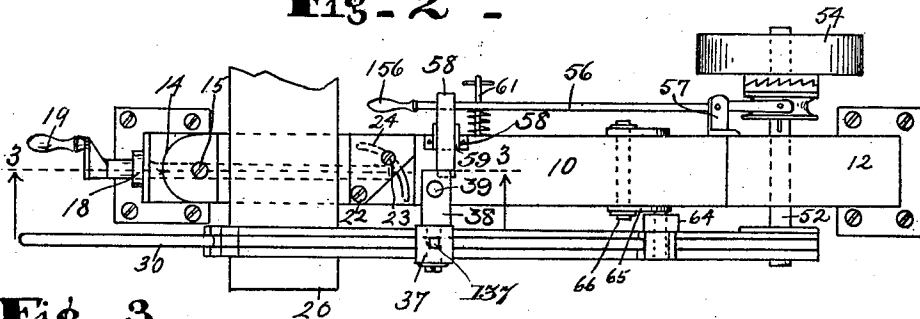
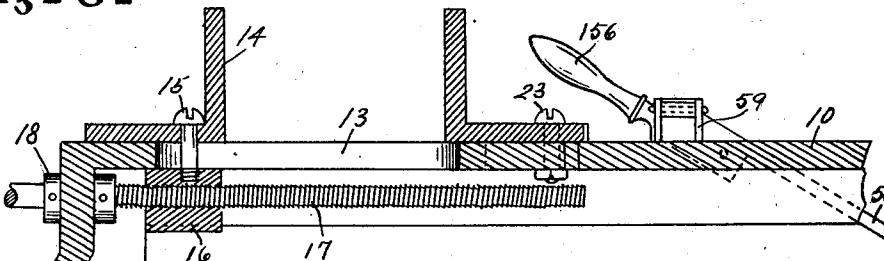

Fig. 3 -



WITNESSES:

*M. M. Gentry.*

*O. M. McLaughlin.*

INVENTOR.  
**Calvin F. Duke.**

BY  
*V. H. Fackwood*  
ATTORNEY.

C. F. DUKE.  
HACKSAW.

APPLICATION FILED JUNE 24, 1909.

1,000,159.

Patented Aug. 8, 1911.

2 SHEETS-SHEET 2.

**Fig. 4.**

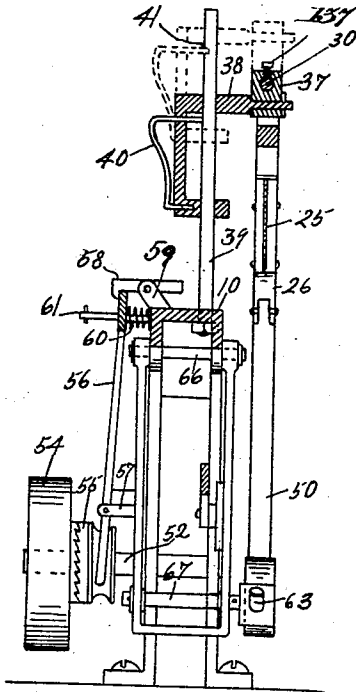

**Fig. 5.**

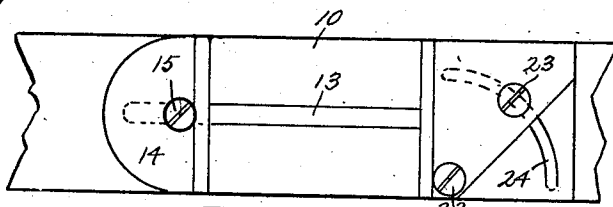

**Fig. 6.**

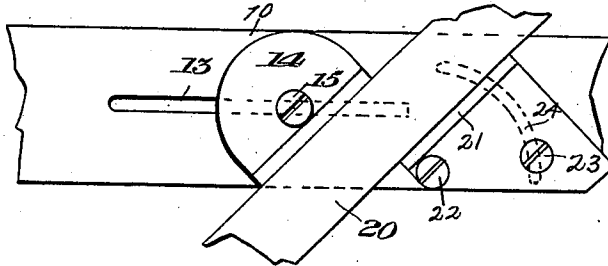

**Fig. 7.**

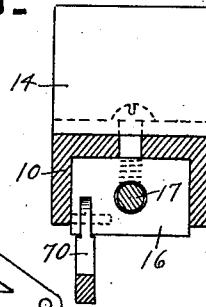

**Fig. 8.**

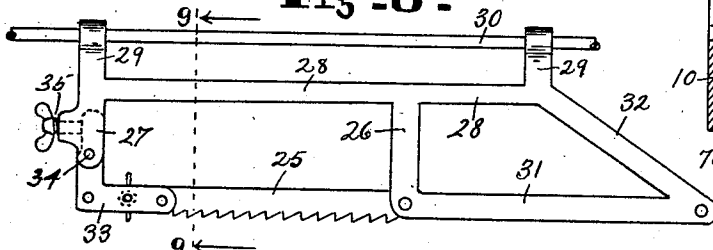

**Fig. 9.**

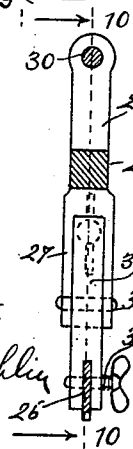

**Fig. 10.**

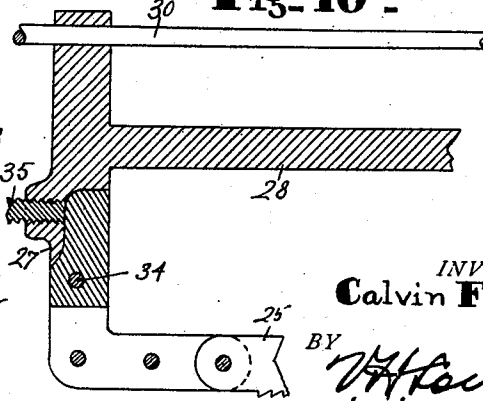

WITNESSES:

*W. M. Kettle.*

*O. M. M. Laughlin.*

INVENTOR.

**Calvin F. Duke.**

BY

*W. H. Lockwood.*  
ATTORNEY.

# UNITED STATES PATENT OFFICE.

CALVIN F. DUKE, OF INDIANAPOLIS, INDIANA.

## HACKSAW.

1,000,159.

Specification of Letters Patent.

Patented Aug. 8, 1911.

Application filed June 24, 1909. Serial No. 504,009.

*To all whom it may concern:*

Be it known that I, CALVIN F. DUKE, of Indianapolis, county of Marion, and State of Indiana, have invented a certain new and useful Hacksaw; and I do hereby declare that the following is a full, clear, and exact description thereof, reference being had to the accompanying drawings, in which like letters refer to like parts.

10 The object of this invention is to improve the construction and operation of hack saws, and especially to cause the saw to have the movement peculiar to hand-operated saws.

15 One feature of the invention consists in mounting the saw reciprocally on an oscillatable support. A rod is mounted on an oscillatable support and the frame of the saw is longitudinally and substantially horizontally reciprocable on said rod.

20 Along with the foregoing is the provision of means for giving to the saw a combined reciprocable and rocking movement. This means consists of an arm mounted rigidly in a sleeve on a crank shaft or other eccentric and a guide pin rigidly extending from said sleeve and reciprocable in an oscillatable bearing block.

25 Another feature of the invention consists in certain peculiar means for clamping and holding the material to be sawed, whereby it may be adjusted to material of different dimensions and to saws of different lengths.

30 The full nature of the invention will be understood from the accompanying drawings and the following description and claims.

35 In the drawings Figure 1 is a side elevation of the machine in full lines, altered positions of parts being shown by dotted lines. 40 Fig. 2 is a plan view of the machine. Fig. 3 is a central vertical section on the line 3—3 of Fig. 2. Fig. 4 is a vertical transverse section on the line 4—4 of Fig. 1. Fig. 5 is a plan view of a portion of the top of the 45 frame and means for clamping the material, said frame being partially broken away and the clamps arranged to hold the material to be sawed transversely. Fig. 6 is the same with the clamps in position to hold the material diagonally. Fig. 7 is a vertical transverse section on the line 7—7 of Fig. 1. Fig. 8 is a side elevation of the saw and its supporting means with an angle bar reversed. 50 Fig. 9 is a transverse section on the line 9—9 of Fig. 8 and Fig. 10 is a longitudinal

section of a portion of the device on the line 10—10 of Fig. 9.

The main frame consists of the horizontal plate 10 and two supports 11 and 12 adapted to be secured to some stationary means. The 60 width of the plate 10 is indicated in Figs. 5 and 6 where it is shown with a longitudinal slot 13 to permit a sliding adjustment of a clamping jaw 14 which is secured by the 65 screw 15 that projects downwardly through the slot 13 to the block 16 below through which the feed screw 17 operates, said feed screw being mounted in the bearing 18 and actuated by the crank 19. Therefore the 70 clamping jaw 14 can by means of the screw 15 be turned to any angle, as indicated in Fig. 6, to accommodate the jaw to any desired position of the article 20 to be sawed. The other jaw 21 is stationary longitudinally but it is angularly adjustable, as shown 75 in Fig. 6, by means of the pivot pin 22 whereby it is secured to the plate 10 and is held in adjusted position by the bolt 23 passing through the slot 24 in plate 10 that is curved concentrically to the pivot 22. 80

The saw 25 is secured to the lower ends of the two arms 26 and 27 of a frame composed of said arms and the horizontal bar 28 and the two upwardly extending arms 29 that 85 are slidably mounted on the saw supporting rod 30. Said saw frame also has a bar 31 extending rearwardly from the lower end of the arm 26 in alinement with the saw and an oblique bar 32 extends from the rear end of the bar 28 down to the rear end of the 90 bar 31. The forward end of the saw 25 is secured to the angle bar 33 that is pivoted at 34 to the lower end of the bar 27 of the frame and has an upwardly extending end against which the set screw 35 presses and 95 which may be reversed, as seen in Figs. 1 and 8. By tightening said screw 35 the saw can be held taut. The rod 30 which supports the saw frame is longitudinally movable in and supported by the block 37 that is 100 pivoted on an arm from the frame 38 that is supported on the rod 39 which is secured to and extends upwardly from the plate 10. A set screw 37 in said block 37 clamps the rod 30 therein. Said frame 38 is vertically 105 movable on the said rod 39 and is held in place by the spring catch 40 secured to said frame and adapted to project into the notch 41 in the rod 39, see Fig. 4.

The saw is actuated by the arm 50 that is 110

pivoted at its upper end to the rear end of the saw frame and at its lower end is rigidly secured in the sleeve 51 that is mounted on a portion of the crank shaft 52. Said crank shaft 52 is mounted in two ears or brackets 53 extending forward from the inclined portion 12 of the frame and is driven by the pulley 54. The pulley 54 is loosely mounted and is clutched with the shaft 52 by the clutch 55. The clutch is held in operative engagement with the pulley 54 by the lever 56 fulcrumed on the arms 57 from the rear part 12 of the frame, and which has a handle 156 on its upper end. The said bar 56 extends diagonally and forwardly as shown in Figs. 1 and 2. The catch 58 pivoted on the arms 59 secured to the plate 10 of the frame holds the upper end of said lever 56 in position to maintain the operative connection between the pulley 54 and shaft 52. The device is thrown out of operation by releasing the catch 58 whereupon the lever 56 is thrown by the spring 60 on the rod 61.

In order to cause the arm 50 to actuate the saw frame the sleeve 51 is held from rotation or excessive oscillation on a crank shaft 52 by the guide rod 63. Said rod is rigidly connected with the sleeve 51 and slides through a block 64 pivoted on the cross rod 67 which extends through the bars 65 formed into a stirrup that is suspended from the rod 66 on the top 10 of the frame, see Fig. 4. Said bars 65 are held in position by a bracket 68 secured thereto and projecting forwardly and having a pair of holes 69 therein for pivoting the connecting bar 70 that runs therefrom to the block 16 on the screw 17 and jaw 14.

The construction just described gives to the saw a rocking reciprocatory movement such as is given to it when operated by hand. The movement of the parts is indicated by dotted lines in Fig. 1 and the intermediate position is indicated by full lines, and the path of movement of the rear end of the saw frame is also indicated by the dotted lines in Fig. 1 showing it to be curved downwardly toward the rear and upwardly toward the front, whereby the saw is rocked.

The extent of movement of the saw or length of stroke is regulated by adjusting the pivot block 64 on the rod 63 toward or away from the sleeve 51. The nearer said pivot block is to the sleeve 51 the shorter will be the stroke of the saw, and the reverse is true and this adjustment is effected by changing the connection between brackets 68 and connecting bar 70. The purpose of varying the stroke of the saw is to cause it to move as far as possible in each direction in order to do as much sawing as possible with each movement. The extent of the movement of the saw desired depends upon the width of the material sawed. If it be a wide piece of material the saw obviously can have very

little movement until it has reached its limit in either way, but if a narrow article is being sawed the stroke of the saw can be greatly increased, that is, as far as the article will permit in either direction; hence this adjustment increases the working capacity of the saw, especially while sawing narrow articles.

The ends of the saw frame in their reciprocatory movements do not pursue the same lines backward and forward, but the rearward path is on a lower line than the forward path, as indicated by dotted lines in Fig. 1. This causes the rear end of the saw to drop down as it goes backwardly and to push up as it goes forwardly. The sawing movement of the saw is from right to left, as shown in Fig. 1. The connecting bar 70 and arms 68, between the movable jaw 14 and swinging bar 65, vary the distance between the pivot block and sleeve in proportion to the adjusting movement of the movable jaw.

What I claim as my invention and desire to secure by Letters Patent is:

1. A hack saw including a fixed frame adapted to support the work to be sawed, a saw, a frame for holding said saw, means for supporting the saw frame so that said saw frame is reciprocable longitudinally of said supporting means, means for fulcruming said supporting means between the ends thereof and of the saw frame, and means for giving the saw frame a combined longitudinally reciprocable and rocking movement.

2. A hack saw including a fixed frame adapted to support the work to be sawed, a saw, a frame for holding the saw, rocking means vertically movable with reference to said fixed frame for supporting the saw frame so that it is longitudinally reciprocable, oscillatory means for giving said saw frame a combined reciprocable and rocking movement, whereby the saw will ride by gravity upon the work being sawed and have said combined reciprocable and rocking movement while at work, and readily releasable means for supporting said rocking means in an elevated position for holding the saw frame elevated while it is not sawing.

3. A hack saw including a fixed frame adapted to hold the work to be sawed, a vertically extending guide from said fixed frame, a block vertically movable in connection with said guide and having a rocking bearing, and means for giving the saw frame a combined reciprocable and rocking movement.

4. A hack saw including a reciprocatory saw frame, a driving crank shaft, a sleeve on a crank thereof, a rod secured to the sleeve and extending upwardly and pivoted at its upper end to said saw frame, a curved

rod secured to the sleeve and projecting forwardly, a swinging bar, a pivot block connected therewith through which said curved rod slides, a bracket extending forwardly  
5 from said swinging bar at substantially a right angle therefrom, an adjustable jaw for clamping the article to be sawed, and a bar pivotally connected at one end with said clamping jaw and at the other end to said  
10 bracket.

5. A hack saw including a saw frame, rocking means upon which said saw is re-

ciprocable, and means for reciprocating said saw frame which causes the rear end of the saw frame to move through a circuit with  
15 the path of rearward movement below the path of forward movement.

In witness whereof, I have hereunto affixed my signature in the presence of the witnesses herein named.

CALVIN F. DUKE.

Witnesses:

G. H. BOINK,  
O. M. McLAUGHLIN.

Copies of this patent may be obtained for five cents each, by addressing the "Commissioner of Patents  
Washington, D. C."