



INTERNATIONAL APPLICATION PUBLISHED UNDER THE PATENT COOPERATION TREATY (PCT)

<p>(51) International Patent Classification ⁶ : B32B 1/08, 31/30, F16L 11/00</p>	<p>A1</p>	<p>(11) International Publication Number: WO 97/44186 (43) International Publication Date: 27 November 1997 (27.11.97)</p>
<p>(21) International Application Number: PCT/US97/08236 (22) International Filing Date: 15 May 1997 (15.05.97) (30) Priority Data: 60/018,171 23 May 1996 (23.05.96) US (71) Applicant: EAGLE-PICHER INDUSTRIES, INC. [US/US]; 580 Walnut Street, Cincinnati, OH 45202 (US). (72) Inventor: HUNTER, Robin, B.; 19 High Street, Spratton, Northants NN6 8HH (GB). (74) Agents: LUNN, Gregory, J. et al.; Wood, Herron & Evans, L.L.P., 2700 Carew Tower, Cincinnati, OH 45202 (US).</p>	<p>(81) Designated States: AL, AM, AT, AU, AZ, BA, BB, BG, BR, BY, CA, CH, CN, CU, CZ, DE, DK, EE, ES, FI, GB, GE, GH, HU, IL, IS, JP, KE, KG, KP, KR, KZ, LC, LK, LR, LS, LT, LU, LV, MD, MG, MK, MN, MW, MX, NO, NZ, PL, PT, RO, RU, SD, SE, SG, SI, SK, TJ, TM, TR, TT, UA, UG, UZ, VN, YU, ARIPO patent (GH, KE, LS, MW, SD, SZ, UG), Eurasian patent (AM, AZ, BY, KG, KZ, MD, RU, TJ, TM), European patent (AT, BE, CH, DE, DK, ES, FI, FR, GB, GR, IE, IT, LU, MC, NL, PT, SE), OAPI patent (BF, BJ, CF, CG, CI, CM, GA, GN, ML, MR, NE, SN, TD, TG).</p> <p>Published <i>With international search report.</i></p>	

(54) Title: LAMINATED FUEL AND VAPOR RETURN LINES

(57) Abstract

A multi-layer hydrocarbon vapor-impermeable tube (11) is formed with a nylon outer layer (12) and a vapor barrier inner layer (15) such as ETFE, bonded together by two adhesive layers. The laminated tube is coextruded. The shear on the two adhesive layers are adjusted to bias the first adhesive layer (13) towards the nylon outer layer and the second adhesive layer (14) towards the ETFE barrier layer (15). This permits rapid coextrusion of the laminated tubing. Preferably, both adhesive layers are formed from a blend of nylon and ETFE. The ratio of nylon to ETFE can be adjusted so that the first adhesive layer is preferentially adherent to the nylon layer, and the second adhesive layer is preferentially adherent to the ETFE layer, and both adhesive layers are adherent to each other.

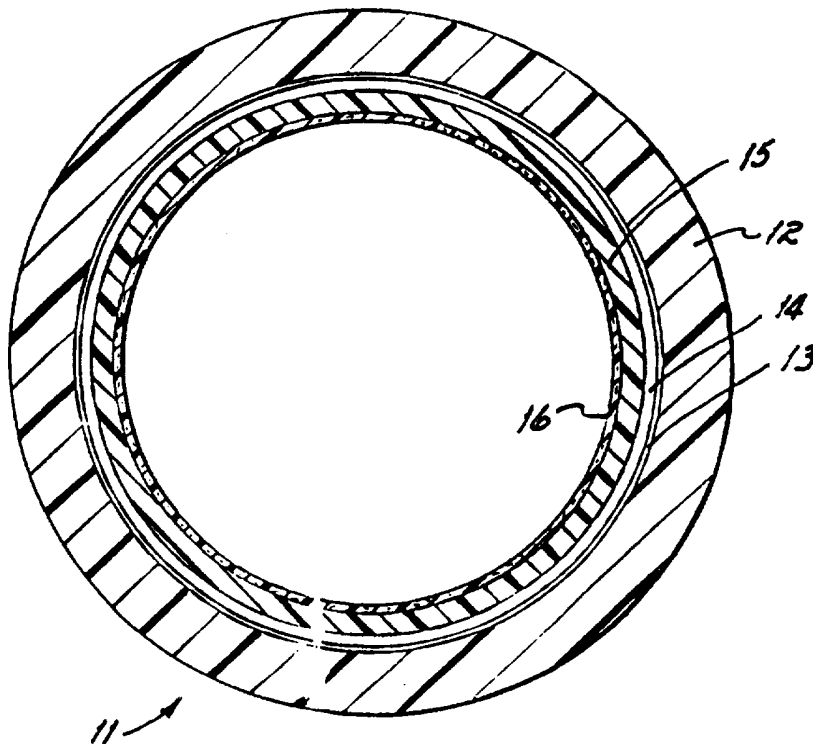

FOR THE PURPOSES OF INFORMATION ONLY

Codes used to identify States party to the PCT on the front pages of pamphlets publishing international applications under the PCT.

AL	Albania	ES	Spain	LS	Lesotho	SI	Slovenia
AM	Armenia	FI	Finland	LT	Lithuania	SK	Slovakia
AT	Austria	FR	France	LU	Luxembourg	SN	Senegal
AU	Australia	GA	Gabon	LV	Latvia	SZ	Swaziland
AZ	Azerbaijan	GB	United Kingdom	MC	Monaco	TD	Chad
BA	Bosnia and Herzegovina	GE	Georgia	MD	Republic of Moldova	TG	Togo
BB	Barbados	GH	Ghana	MG	Madagascar	TJ	Tajikistan
BE	Belgium	GN	Guinea	MK	The former Yugoslav Republic of Macedonia	TM	Turkmenistan
BF	Burkina Faso	GR	Greece			TR	Turkey
BG	Bulgaria	HU	Hungary	ML	Mali	TT	Trinidad and Tobago
BJ	Benin	IE	Ireland	MN	Mongolia	UA	Ukraine
BR	Brazil	IL	Israel	MR	Mauritania	UG	Uganda
BY	Belarus	IS	Iceland	MW	Malawi	US	United States of America
CA	Canada	IT	Italy	MX	Mexico	UZ	Uzbekistan
CF	Central African Republic	JP	Japan	NE	Niger	VN	Viet Nam
CG	Congo	KE	Kenya	NL	Netherlands	YU	Yugoslavia
CH	Switzerland	KG	Kyrgyzstan	NO	Norway	ZW	Zimbabwe
CI	Côte d'Ivoire	KP	Democratic People's Republic of Korea	NZ	New Zealand		
CM	Cameroon			PL	Poland		
CN	China	KR	Republic of Korea	PT	Portugal		
CU	Cuba	KZ	Kazakistan	RO	Romania		
CZ	Czech Republic	LC	Saint Lucia	RU	Russian Federation		
DE	Germany	LI	Liechtenstein	SD	Sudan		
DK	Denmark	LK	Sri Lanka	SE	Sweden		
EE	Estonia	LR	Liberia	SG	Singapore		

-1-

Laminated Fuel and Vapor Return Lines

Background of the Invention

Hydrocarbon emissions have become a major concern with environmental agencies throughout the world. One way to reduce hydrocarbon emissions from automobiles is to prevent hydrocarbon vapor emissions through fuel lines and vapor lines. In the past, these fuel lines have been formed from nylon which is particularly strong, but has relatively poor hydrocarbon vapor barrier characteristics. A solution to this has been to provide a laminated fuel line having one or more layers that provide improved barrier characteristics laminated to nylon. Fuel lines, as opposed to vapor lines, also require an inner conductive layer to permit dissipation of static charge created as the fuel passes through the fuel line.

Most of the barrier layers tend to be fluorinated hydrocarbons such as ethylene tetrafluoroethylene (ETFE) and polytetrafluoroethylene (PTFE). The problem with these barrier layers is

-2-

they do not adhere well to nylon. Plasma treatment of the fluorinated hydrocarbon polymers has been employed and is successful to some extent, but still suffers problems with delamination and further, is relatively expensive. *Noone et al.* U.S. Patent 5,383,087 discloses using an outer nylon layer bonded to an inner barrier layer by a compatibilizing adhesive. Unfortunately, in practice it is very difficult to get both the nylon and the fluorinated polymer to both adhere to the compatibilizing adhesive.

Summary of the Invention

The present invention is premised on the realization that a polyamide or nylon outer layer can be laminated to a fluorinated polymer inner layer by a dual adhesive layer. These four layers are coextruded together with the inner adhesive layer, adjacent the outer surface of the fluorinated polymer, extruded under high shear conditions, whereas the outer adhesive layer adjacent the nylon is extruded under low shear conditions. This causes the inner layer to be biased toward the fluorinated polymer layer and the outer layer to be biased toward the nylon layer.

The adhesives can be the same or different adhesives. Different adhesives can be selected to promote further adhesion between the respective nylon and fluorinated polymer layers. Further, the present invention can include an innermost conductive layer formed from a carbon or metal-impregnated fluorinated polymer.

The objects and advantages of the present invention will be further appreciated in light of the following detailed description and drawings in which:

Brief Description of the Drawings

5 FIG. 1 is a perspective view of a fuel line made according to the present invention.

 FIG. 2 is a cross-sectional view taken at lines 22 of Fig. 1.

Detailed Description

 The present invention is a laminated tube 11 adapted to
10 transport either fuel or hydrocarbon vapors. The tube 11 includes an
 outer layer 12 which is a cold impact resistant layer, preferably formed
 from a polyamide and most particularly formed from a nylon. Adjacent
 outer layer 12 is a first compatibilizing adhesive layer 13. Adjacent first
 compatibilizing adhesive layer 13 is a second compatibilizing adhesive
15 layer 14. These two layers combined promote the adhesion of the nylon
 layer 12 to a barrier layer 15. The innermost layer adhered to the barrier
 layer 15 is an optional conductive layer 16.

 All layers are formed from melt-processable thermoplastics.
 The outer layer 12 may be composed of any melt-processable,
20 extrudable, thermoplastic material which is resistant to ultraviolet
 degradation, extreme changes in heat, exposures to environmental
 hazards such as zinc chloride, and degradation upon contact with engine
 oil and brake fluids. These are all standard requirements for a fuel line.

-4-

In general, the exterior layer is formed from a polyamide, preferably nylon 11, nylon 12 or nylon 6. These thermoplastic materials are commercially available under trademarks such as Santoprene, Kraten, Seralink and Vichem. The nylon outer layer can have a thickness of about 685
5 microns to about 715 microns, with about 700 microns preferred.

Compatibilizing adhesive layer 13 adjacent layer 12 is a thermoplastic material which is adherent to the nylon layer 12 and also adherent to the second compatibilizing adhesive layer 14. Suitable adhesive layers would include melt-processable thermoplastic
10 fluoroplastic polymers such as polyvinylfluoride compounds including polyvinylidene fluoride polymers, polyvinyl fluoride polymers, and mixtures thereof. Particularly suitable is a blend of a fluorinated polymer adhesive and a polyamide adhesive. One such adhesive is sold under the trademark Daiken DUX 43J. This adhesive is about 60% nylon
15 and 40% ETFE by weight.

The first compatibilizing adhesive layer 13 can be extremely thin and generally will be about 10 microns to 15 microns. Generally, its thickness will depend upon the processing conditions, as discussed below. A preferred thickness is about 10 microns.

20 The second compatibilizing adhesive layer 14 can be any adhesive layer which is compatible with both the barrier layer 15 and the first compatibilizing adhesive layer. Both adhesive layers 13 and 14 can be the same material or different blends of the same materials. In one preferred embodiment, the first compatibilizing adhesive is a blend of

-5-

polyamide (nylon) and fluorinated polymer. The second compatibilizing adhesive layer is also a blend of polyamide and fluorinated polymer. But the first compatibilizing adhesive layer has added polyamide to promote adhesion with the nylon outer layer. In other words, the first compatibilizing adhesive is preferentially adherent to the nylon layer relative to the barrier layer. This is effected by increasing the percentage of nylon in the adhesive. Likewise, the second compatibilizing adhesive should be preferentially adherent to the barrier layer, relative to the nylon layer. This is effected by increasing the fluorinated polymer content of the second compatibilizing adhesive. The second adhesive would be the Daiken DUX 43J with added ETFE to provide a 40% nylon/60% ETFE blend by weight.

The thickness of the second compatibilizing adhesive layer again will be determined by processing conditions, as discussed below. Generally, its thickness will be 80 to 100 microns with 90 microns preferred.

The barrier layer 15 is again a melt-processable, thermoplastic material. Generally, this will be a fluorinated polymer. Preferred materials include polytetrafluoroethylene, ethylene tetrafluoroethylene, and polyvinylidene fluoride. Ethylene tetrafluoroethylene can be purchased from Daiken under the trademark EP 160.

Optionally, the tube can include an innermost conductive layer 16 which would be used for fuel lines. This would not be included

-6-

for vapor return lines. The conductive layer will be a carbon fiber or metal-impregnated material which is compatible with the barrier layer 15. It will generally be formed from the same polymer as layer 15 impregnated with a sufficient amount of conductive materials to dissipate an electrostatic charge in the range of 10^{-4} to 10^{-9} ohm/cm². Conductive metals include copper, silver, gold, nickel, silicon and mixtures thereof, however carbon fibers are preferred. The amount of conductive material contained in this layer is 5% to 10% by weight. One such conductive material can be purchased from Daiken EP610AS.

10 The tube of the present invention is formed by coextrusion. The temperatures and flow rates will vary depending upon the particular polymer. However, with respect to the first and second compatibilizing adhesive layers 13 and 14, the flow rates are adjusted to manipulate shear to promote adhesion to the outer nylon layer and the inner barrier layer, respectively. Generally, high shear conditions promote the adhesion of the second compatibilizing adhesive layer 14 to the barrier layer 15. Likewise, low shear characteristics bias the first compatibilizing adhesive layer 13 toward the nylon layer. This promotes adhesion between the respective layers and greatly improves cold impact delamination characteristics.

20 The tube 11 is formed by coextruding all four or five layers (depending upon whether the inner conductive layer is present). Improved adhesion is obtained by manipulating the two adhesive layers 13 and 14 to produce a bias either toward the ETFE or the nylon, thereby

-7-

using two layers of adhesive and manipulating them to create a bias toward nylon 12 on the fourth layer and a bias toward ETFE on the third layer. Further, one can improve relative adhesion to the barrier layer and the nylon layer, respectively, by selecting two different adhesives, each having preference for these respective layers. However, the adhesive layers must be compatible and adhesive to each other.

The invention will be further appreciated in light of the following detailed example.

EXAMPLE

A laminated tube used for the fuel line is formed with an outer layer 12 of nylon 12 supplied by UBE Chemical of Japan, having a thickness of 700 microns. The first compatibilizing adhesive layer 13 is formed from a blend of nylon and ethylene tetrafluoroethylene supplied by Daiken Chemical, also of Japan. Its thickness is 10 microns. The second compatibilizing adhesive layer 14 is formed from the same adhesive as layer 13, and has a thickness of 90 microns. The barrier layer 15 is formed from nonconductive ETFE supplied by Daiken and has a thickness of 150 microns. The inner conductive layer 16 is conductive ETFE sold by Daiken and has a thickness of 50 microns. These are coextruded using the following extruder settings with Extruder 1 used to extrude the inner conductive layer, Extruder 2 the barrier layer, Extruder 3 the second compatibilizing adhesive layer, Extruder 4 the first compatibilizing adhesive layer, and Extruder 5 the nylon layer.

PROCESS SPECIFICATIONS

Extruder Temperature Settings.(° C)

	Extruder 1 Size 30 mm	Extruder 2 Size 45 mm	Extruder 3 Size 30 mm	Extruder 4 Size 30 mm	Extruder 5 Size 45 mm
Zone 1	300	300	210	210	210
Zone 2	300	300	225	225	230
Zone 3	310	300	230	230	240
Zone 4	310	310	240	240	240
Zone 5	310	310	240	240	240

5

10

15

20

The extruders were all set to the parameters listed above and extruder speeds adjusted to meet the layer thicknesses previously referenced. The carbon-filled layer of ETFE acts as a conductive layer for the fuel tube. The carbon-filled layer is of the same material as the ETFE nonconductive layer and accordingly adheres to this. This nonconductive ETFE acts as the barrier layer. The adhesive, when subjected to shear, has an effect on its ability to adhere to either nylon 12 or ETFE. Using two extruders for the adhesive layer changes the bias of the adhesive to have good adhesion to the nylon layer through extruder 4 and the ETFE through extruder 3. This method is not affected by pressure or linear speed and therefore the process is more stable with a larger window for success. The produced tube easily withstood industry-standard cold impact tests without delaminating and accordingly is useful as a fuel line for automobiles.

25

This has been a description of the present invention, along with the preferred method of practicing the invention. However, the invention itself should only be defined by the appended claims wherein we claim:

-9-

1. A method of forming a multi-layer tube for hydrocarbon transmission comprising an outermost protective layer, an inner hydrocarbon barrier layer, and a first and second compatibilizing adhesive layer, wherein said tubing is formed by simultaneously
5 coextruding the four layers, wherein the first compatibilizing adhesive layer is biased toward said protective layer, and said second compatibilizing adhesive layer is biased toward said barrier layer.

2. The method claimed in claim 1 wherein said protective layer is nylon.

3. The method claimed in claim 1 wherein said first and second compatibilizing adhesive layers are formed from the same material.

4. The method claimed in claim 1 further comprising coextruding an innermost conductive layer adhered to said barrier layer.

-10-

5. The method claimed in claim 2 wherein said barrier layer is a fluoropolymer.

6. The method claimed in claim 5 hwerein said first and second compatibilizing adhesive layers comprise a blend of nylon and fluoropolymer.

7. The method claimed in claim 2 wherein said first compatibilizing adhesive is preferentially adherent to said outermost nylon layer, and said second compatibilizing adhesive layer is preferentially adherent to said hydrocarbon barrier layer, and said first
5 and second compatibilizing adhesive layers are adherent to each other.

8. The method claimed in claim 6 wherein said first compatibilizing adhesive layer has a higher percentage by weight of nylon.

9. A multi-layer tube made according to the method of claim 1.

-11-

10. A multi-layer tube made according to the method of claim 2.
11. A multi-layer tube made according to the method of claim 3.
12. A multi-layer tube made according to the method of claim 4.
13. A multi-layer tube made according to the method of claim 5.
14. A multi-layer tube made according to the method of claim 6.
15. A multi-layer tube made according to the method of claim 7.
16. A multi-layer tube made according to the method of claim 8.

-12-

17. A multi-layer tube comprising a nylon outer layer and a
ETFE barrier separated by a first and second compatibilizing adhesive
layer;

5 wherein said first compatibilizing adhesive layer is bonded
to an inner surface of said nylon outer layer, and to an outer surface of
said second compatibilizing adhesive layer;

and said second compatibilizing adhesive layer has an
inner surface bonded to an outer surface of said barrier layer;

10 wherein said first compatibilizing adhesive layer comprises
a blend of nylon and ETFE and is preferentially adherent to said nylon
layer relative to said barrier layer;

wherein said second compatibilizing adhesive layer
comprises a blend of nylon and ETFE and is preferentially adherent to
said barrier layer relative to said nylon layer.

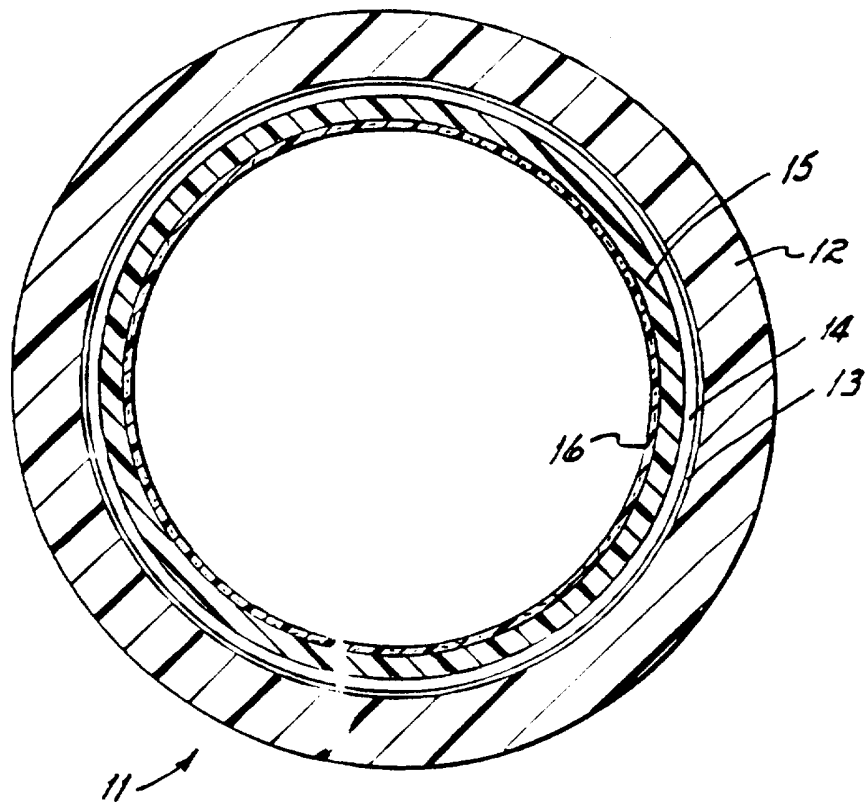
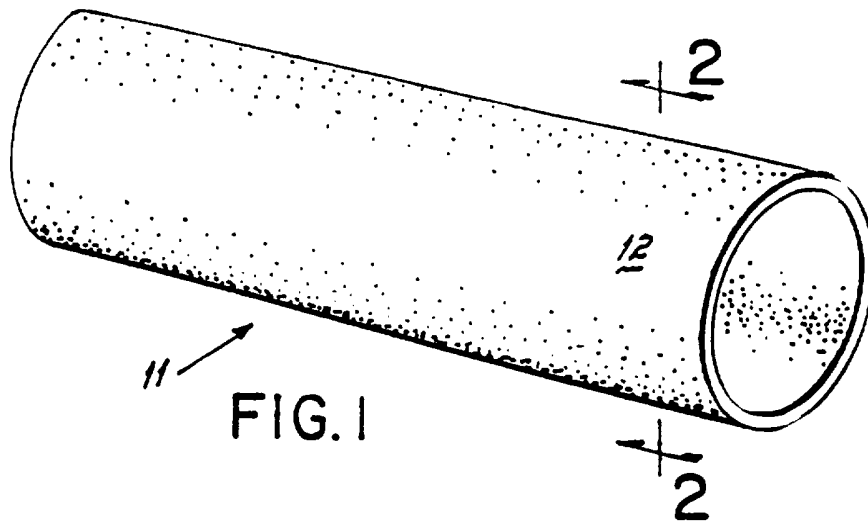

INTERNATIONAL SEARCH REPORT

International application No.
PCT/US97/08236

A. CLASSIFICATION OF SUBJECT MATTER IPC(6) : B32B 1/08, 31/30; F16L 11/00 US CL : 264/171.1, 171.26, 171.27, 171.28; 138/137, 138; 428/36.91 According to International Patent Classification (IPC) or to both national classification and IPC		
B. FIELDS SEARCHED Minimum documentation searched (classification system followed by classification symbols) U.S. : 264/171.1, 171.26, 171.27, 171.28; 138/137, 138; 428/36.91 Documentation searched other than minimum documentation to the extent that such documents are included in the fields searched Electronic data base consulted during the international search (name of data base and, where practicable, search terms used) GPIC search terms: tube, hose, pipe, coextruding, adhesive, conductive		
C. DOCUMENTS CONSIDERED TO BE RELEVANT		
Category*	Citation of document, with indication, where appropriate, of the relevant passages	Relevant to claim No.
Y	US 3,376,181 A (LARSON et al) 02 April 1968 (02.04.68), see entire document.	1-17
Y	US 4,370,186 A (BLANDIN et al) 25 January 1983 (25.01.83), see entire document.	1-17
Y	US 5,170,011 A (MARTUCCI) 08 December 1992 (08.12.92), see entire document.	5, 6, 9-17
Y	US 5,437,311 A (REYNOLDS) 01 August 1995 (01.08.95), see entire document.	5, 6, 9-17
Y	US 5,474,109 A (STOPPELMANN et al) 12 December 1995 (12.12.95), see entire document.	1-17
Y, P	US 5,580,405 A (PALMER) 03 December 1996 (03.12.96), see entire document.	1-17
<input type="checkbox"/> Further documents are listed in the continuation of Box C. <input type="checkbox"/> See patent family annex.		
* Special categories of cited documents:	*T* later document published after the international filing date or priority date and not in conflict with the application but cited to understand the principle or theory underlying the invention	
A document defining the general state of the art which is not considered to be of particular relevance	*X* document of particular relevance; the claimed invention cannot be considered novel or cannot be considered to involve an inventive step when the document is taken alone	
E earlier document published on or after the international filing date	*Y* document of particular relevance; the claimed invention cannot be considered to involve an inventive step when the document is combined with one or more other such documents, such combination being obvious to a person skilled in the art	
L document which may throw doubts on priority claim(s) or which is cited to establish the publication date of another citation or other special reason (as specified)	*G* document member of the same patent family	
O document referring to an oral disclosure, use, exhibition or other means		
P document published prior to the international filing date but later than the priority date claimed		
Date of the actual completion of the international search	Date of mailing of the international search report	
07 JULY 1997	27 AUG 1997	
Name and mailing address of the ISA/US Commissioner of Patents and Trademarks Box PCT Washington, D.C. 20231	Authorized officer <i>JAN SILBAUGH</i> JAN SILBAUGH	
Facsimile No. (703) 305-3230	Telephone No. (703) 308-3829	