

May 7, 1935.

F. C. SUTLIFFE  
HYPODERMIC INJECTOR  
Filed Nov. 9, 1931

2,000,262

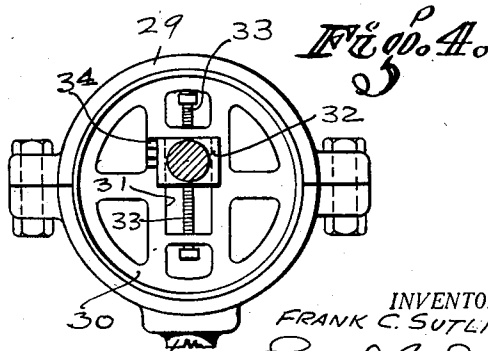
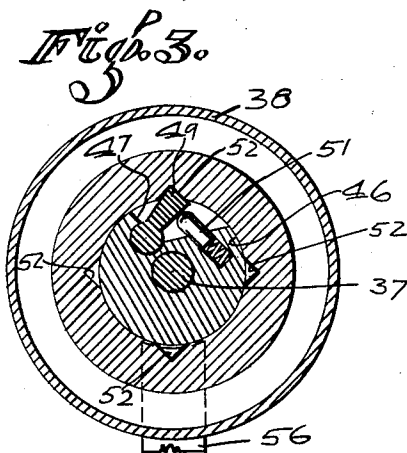
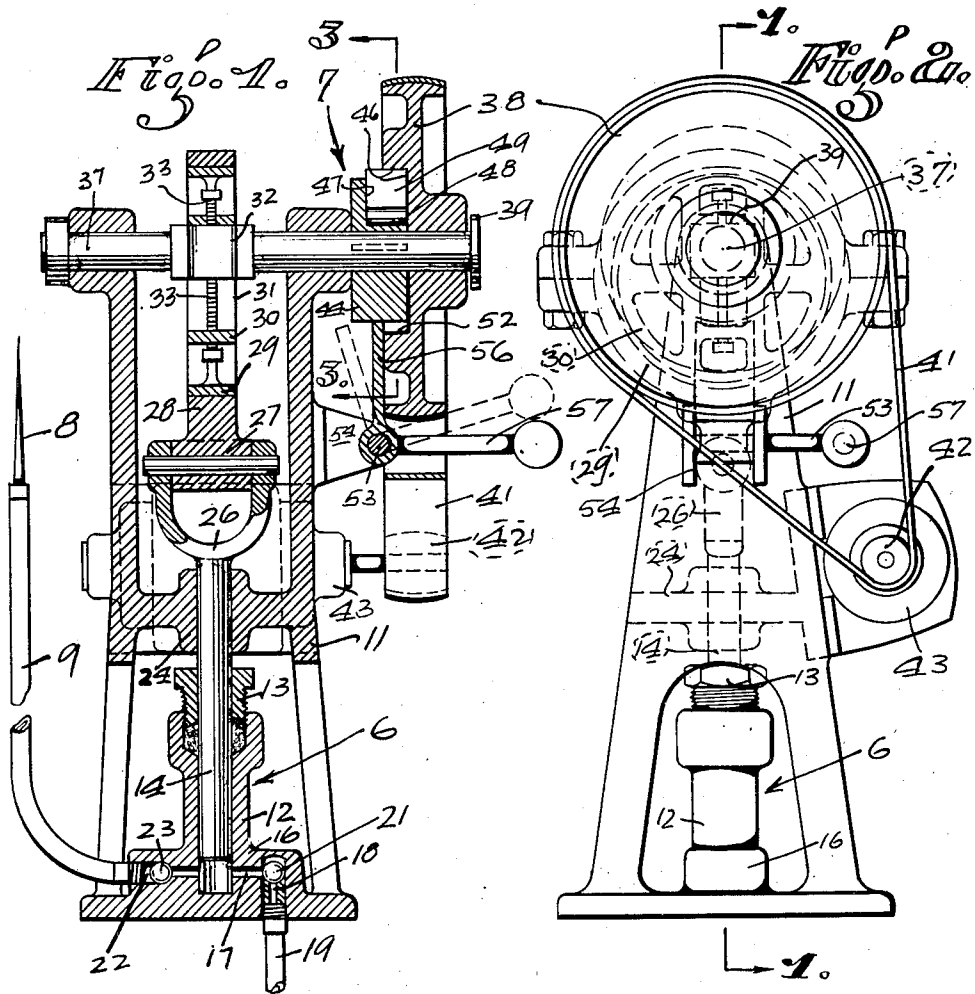

INVENTOR.  
FRANK C. SUTLIFFE  
BY *Frederick Johnson*  
ATTORNEYS.

# UNITED STATES PATENT OFFICE

2,000,262

## HYPODERMIC INJECTOR

Frank C. Sutcliffe, San Francisco, Calif., assignor  
to William Joyner, San Francisco, Calif.

Application November 9, 1931, Serial No. 573,768

4 Claims. (Cl. 99—2)

The invention relates to a liquid injecting device.

The primary object of the invention is to provide an injecting mechanism, whereby a curing liquid may be readily injected in objects to be cured or preserved such as into ham or the like; means being provided to regulate the amount of liquid injected, and to force out equal amounts of curing liquids every time the device is actuated.

An object of the invention is to provide an injecting device wherein a hypodermic needle or the like, is connected to liquid forcing mechanism, when the latter is actuated so as to force a predetermined amount of liquid through the needle into the object in which the needle is inserted; the actuating means of the liquid forcing mechanism being normally inoperative, and being rendered operative only for sufficient length of time to inject a desired charge of liquid through the needle.

Other objects and advantages are to provide a liquid injecting device that will be superior in point of simplicity, inexpensiveness of construction, positiveness of operation, and facility and convenience in use and general efficiency.

In this specification and the annexed drawing, the invention is illustrated in the form considered to be the best, but it is to be understood that the invention is not limited to such form, because it may be embodied in other forms; and it is also to be understood that in and by the claims following the description, it is desired to cover the invention in whatsoever form it may be embodied.

The invention is clearly illustrated in the accompanying drawing, wherein

Fig. 1 is a sectional view of the device constructed in accordance with my invention, the section being taken on the line 1—1 of Fig. 2.

Fig. 2 is a side view of the device.

Fig. 3 is a sectional view of the driving and tripping mechanism of the device, the section being taken on the line 3—3 of Fig. 1.

Fig. 4 is a sectional detail view of the adjustable eccentric.

In its general organization my invention includes a syringe or plunger 6, a driving mechanism 7, and a hypodermic needle 8 connected by a flexible conduit 9 to the discharge of the plunger 6.

In detail the device comprises a frame 11 on the base of which is a plunger cylinder 12. In the upper end of the cylinder 12 is a packing gland 13 through which slidably extends a plunger

piston 14 working in the cylinder 12. The lower end of the cylinder 12 is formed into a valve head 16 having a passage 17 at right angles across the bottom of the cylinder 12. At one end of the passage 17 is an intake 18 to which is connected a liquid supply conduit 19. The intake 18 is controlled by a check valve 21 opened by suction created in the cylinder 12 during the upward stroke of the piston 14.

In the other end of the passage 17 is a discharge 22 to which is connected the end of the flexible conduit 9. A check valve 23 controls the discharge. The valve 23 is closed by the suction in the cylinder 12 and is opened by the pressure in the cylinder during the downward stroke of the piston 14.

Thus in one reciprocation, or two strokes, liquid is drawn into the cylinder 12 and forced out through the conduit 9 and the needle 8 into the object wherein the needle 8 is inserted.

The plunger rod or piston 14 is guided also by a bearing 24 on the frame 11. On the upper end of the piston 14 is a yoke 26 disposed above the bearing 24. In the yoke 26 is journaled a crosshead 27. A connecting rod 28 is connected to the crosshead 27. The connecting rod 28 extends from an eccentric band 29 in which latter rotates an eccentric 30, adjustably mounted on a shaft 31 journaled in the upper end of the frame 11. The eccentric 30 has a diametrical slot 31 on the longitudinal edges of which is slidable a block 32 fixed on the shaft 31, to rotate the eccentric 30 in the band 29 thereby to reciprocate the rod 28 and the piston 14.

In each end of the slot 31 is threadedly secured an adjusting screw 33. The opposed screws 33 bear against opposite ends of the block 32 to hold the eccentric 30 in an adjusted position. On the face of the eccentric 30 and adjacent the block 32 I provide a plurality of graduation marks 34, each mark corresponding to a certain stroke length of the piston 14. The block 32, of course, is the fixed center on the shaft 31, and the adjusting of the screws 33 moves the eccentric 30, and particularly the slot 31, relatively to the block 32 thereby changing the eccentricity thereof, and that, of course, results in varying the throw of the eccentric and the stroke of the piston 14. In this manner a certain definite predetermined amount of liquid can be pumped through the needle 8 at all times.

The driving mechanism 7 includes a fly-wheel 35 freely rotatable on the outer end of the shaft 31 and being held against removal by a flange

39 on the end of said shaft. The fly-wheel 38 is driven by a belt 41 and pulley 42, the latter being driven by an electric motor 43 on the side of the frame 11. The motor 43 thus drives the fly-wheel 38 constantly, but the latter merely idles on the shaft 37 without imparting rotation to the same.

The fly-wheel 38 is connectible to the shaft 37 by means of a collar 44 keyed on the shaft 37 and disposed partly within a circular recess 46 in the fly-wheel 38. The collar 44 has a recess 47 extending from the outer periphery inwardly of the collar and has a transverse socket 48 formed in its inner corner. In the socket 48 fits a cylindrical edge of a pawl 49 so that the said pawl 49 is turnable in the recess. The outer ends of the pawl 49 is formed with sharp corners. A spring plunger 51 in a wall of the recess 47 urges the pawl 49 outwardly against the inner periphery of the annular recess 46 in the fly-wheel 38.

There are four angular indentations 52 in the inner periphery of said recess 46, each of which is adapted to be engaged by the outer corner of the pawl 49. When the fly-wheel 38 is rotated in a contra-clockwise direction, viewing Fig. 3, the engagement of the pawl 49 with one of the indentations 52 establishes driving connection between the fly-wheel 38 and the collar 44, which latter drives the shaft 37 to reciprocate the plunger piston 14.

The pawl 49 is controlled by a tripping mechanism, which includes a pin 53 journaled in a bearing bracket 54 on the frame 11, and below the fly-wheel 38. On the pin 53 is fixed a tripping arm 56 extending upwardly against the periphery of the collar 44. The free end of the arm 56 is curved to fit over the collar periphery. It is to be noted that the arm 56 is swingable toward and away from the fly-wheel 38, into and out of engagement with the collar periphery. A counter-weight arm 57 extends at right angles to the tripping arm 56 to normally hold the latter in collar engaging position alongside the fly-wheel 38. In this normal position the arm 56 operates to urge and hold the pawl 49 in the recess 47 thereby to prevent the said pawl to engage the indentations 52, thus allowing the free idle rotation of the fly-wheel 38 on the shaft 37.

In operation the needle 8 is inserted into the ham or the like article to be cured; then the counter-weight arm 57 is thrown upwardly into the dotted line position, shown in Fig. 1, and is immediately released and allowed to drop back to its normal position. Thus the tripping arm 56 is momentarily moved away from the pawl 48 and the latter is allowed to drop into one of the indentations 52 and establish the driving connection between the driving mechanism 7 and the plunger 6.

Inasmuch as the weight on the arm 57 immediately returns the arm 56 into normal position, the pawl 49 is again urged into inoperative position out of engagement with the indentation 52 after one revolution. In this manner each tripping of the arm 56 results in only one revolution of the shaft 37, which corresponds to an upward and downward stroke of the piston 14, and to a single predetermined charge injected through the needle 8.

Usually in curing ham, for instance, the same is sorted according to weight, then hams of the same weight are cured in a group. Therefore the stroke of my machine is first adjusted to correspond to the charge of curing liquid required for ham of that size. Then every time the needle 8 is inserted in the ham, in the usual manner, the lever 57 is tripped and immediately released to permit only one revolution of the shaft 37 and a single charge is thus injected in each ham.

It will be recognized that a device is provided which greatly improves the speed, efficiency, and accuracy of injecting curing liquids or the like into substances of any character, and particularly in hams to be cured; the device is readily adjustable to inject a predetermined amount of curing liquid accurately, at each operation. The device is simple in construction, positive in operation, its operation does not require any particular skill, therefore it readily lends itself to effective application by the labor ordinarily available.

Having thus described this invention, what I claim and desire to secure by Letters Patent is:

1. In a device of the character described a hypodermic needle, a flexible conduit connected thereto, reciprocating means to force a predetermined amount of liquid through said conduit and out through said needle, driving means and releasable means of connection between the driving means and the reciprocating means to transmit movement for one revolution when released, and to disconnect the driving means from the reciprocating means other times.

2. In a device of the character described a hypodermic needle, a flexible conduit, a reciprocating mechanism to force a liquid through said conduit and said needle, an end of the conduit being connected to the needle and its other end to the discharge of said mechanism, a driving mechanism for the reciprocating mechanism, means of connection between the said mechanism being normally inoperative, and means to render said connection means operative at will for one reciprocation of the reciprocating mechanism at a time.

3. The combination with a plunger, and an intermittent driving mechanism therefor, of a hypodermic needle connected to the discharge of the plunger, and a tripping mechanism normally holding the driving mechanism disconnected from the plunger, and when tripped establishing operative connection between said plunger and said mechanism for only one reciprocation of the plunger.

4. The combination with a plunger and an intermittent driving mechanism therefor, of a hypodermic needle connected to the discharge of the plunger; means to adjust the stroke of the plunger to a predetermined liquid discharge through the needle; and a tripping mechanism normally holding the driving mechanism disconnected from the plunger, and when tripped establishing operative connection between said plunger and said mechanism for only one reciprocation of the plunger.

FRANK C. SUTLIFFE.