

J. H. SNYDER.
Horseshoe Machine.

No. 108,530.

Patented Oct. 18, 1870.

Fig. 1.

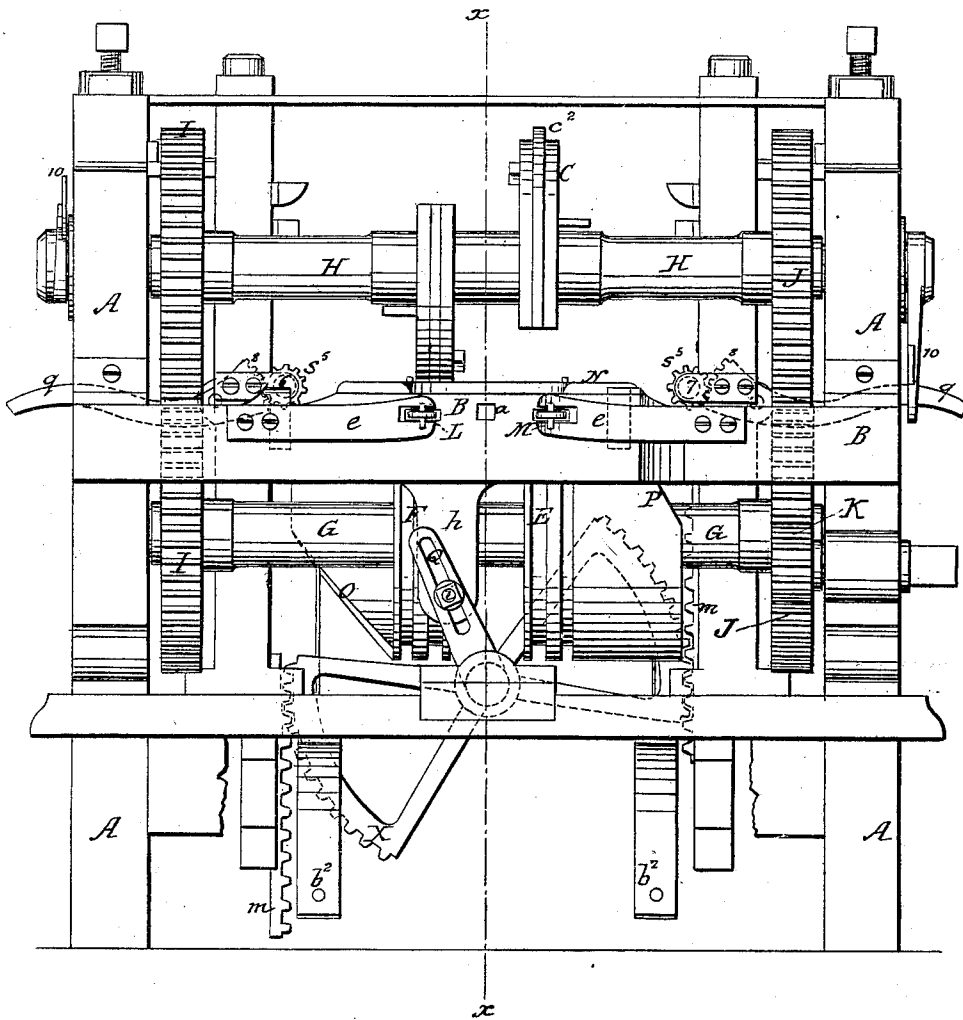

Witnesses.
Edward C. Rehill.
C. M. Cully.

Inventor.
J. H. Snyder
per J. M. Justice
att'y.

J. H. SNYDER.
Horseshoe Machine.

No. 108,530.

Patented Oct. 18, 1870.

Fig. 2.

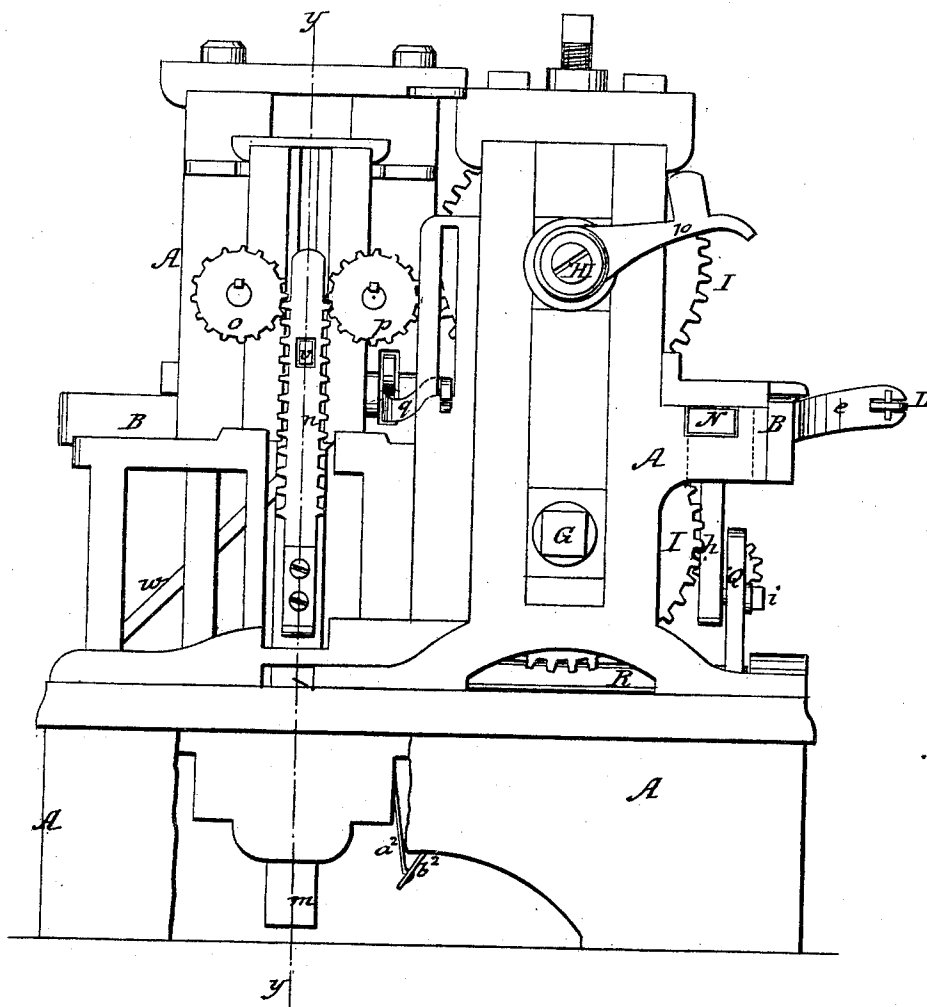

Witnesses:
Edward C. Peckill
E. McCully.

Inventor:
J. H. Snyder
By atty
J. M. Justice

J. H. SNYDER.
Horseshoe Machine.

No. 108,530.

Patented Oct. 18, 1870.

Fig. 3.

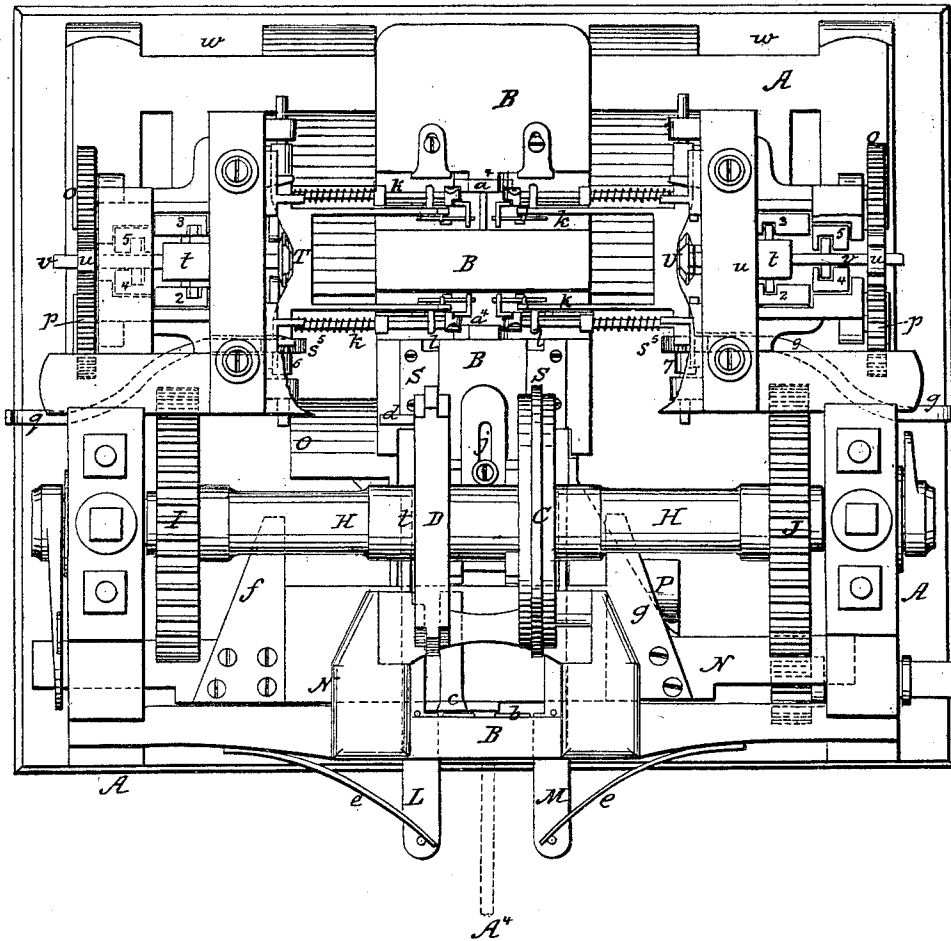

Witnesses.
Edward C. Rehill.
C. M. Leully

Inventor.
J. H. Snyder
By J. M. Dutice

J. H. SNYDER.
Horseshoe Machine.

No. 108,530.

Patented Oct. 18, 1870.

Fig. 4.

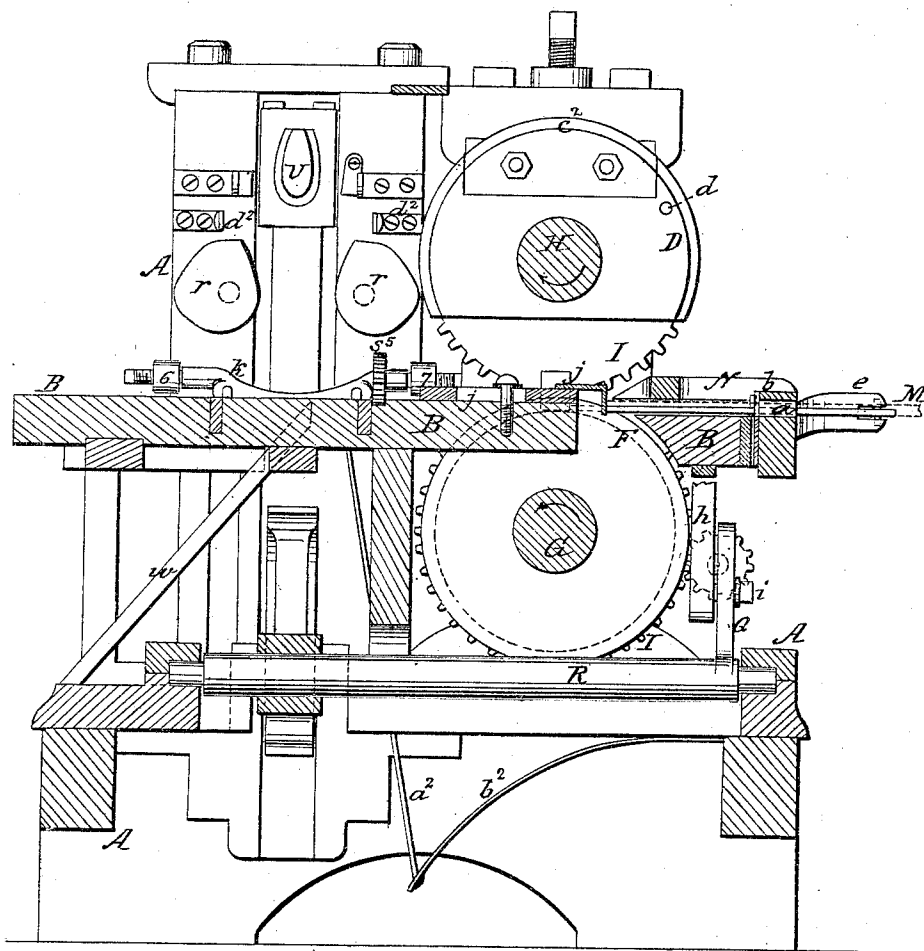

Witnesses.
Edward C. Keshill.
E. M. Cully.

Inventor.
J. H. Snyder
per atty
J. M. Justice.

J. H. SNYDER.
Horseshoe Machine.

No. 108,530.

Patented Oct. 18, 1870.

Fig. 5.

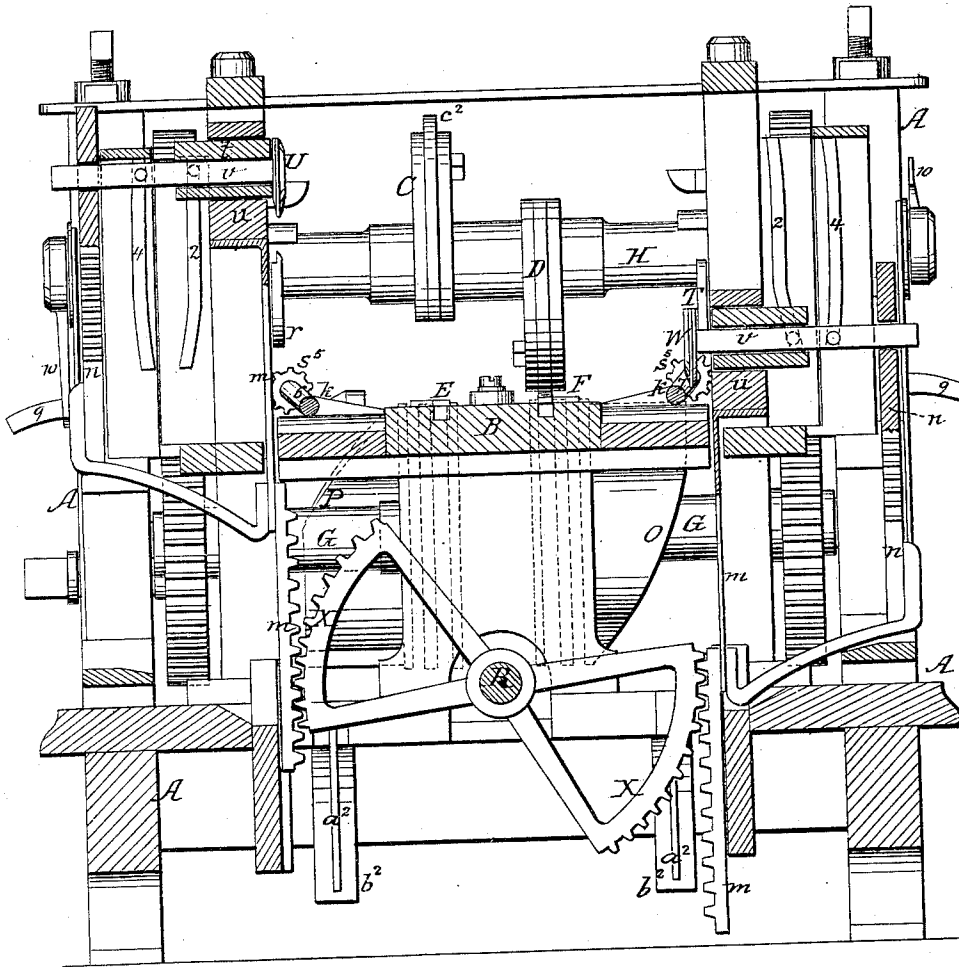

Fig. 6.

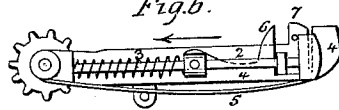
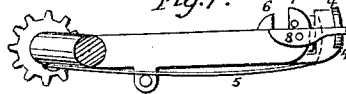

Fig. 7.



Witnesses.
Edward Bleckhill
Edm. Cully

Inventor.
J. H. Snyder
per
J. McArthur

UNITED STATES PATENT OFFICE.

JOHN H. SNYDER, OF TROY, NEW YORK.

IMPROVEMENT IN MACHINES FOR MAKING HORSESHOES.

Specification forming part of Letters Patent No. **108,530**, dated October 18, 1870.

To all whom it may concern:

Be it known that I, JOHN H. SNYDER, of Troy, of Rensselaer county, in the State of New York, have invented a new and useful Machine for Making Horseshoes; and I do hereby declare that the following is a full and exact description thereof, reference being had to the accompanying drawing, making part of this application.

Previous to my invention machines have been used for making horseshoes complete, except the toe and heel calks, which are sometimes needed, and the nail-holes; and it has been suggested, and I believe machines have been made for the purpose, to make the shoe complete, nail-holes and all, by machinery.

My invention relates to certain new and useful improvements in that kind of horseshoe-machines in which the bar of iron fed in is simply cut up and formed into a shoe, with the exception of the toe and nail holes, which are to be made when the shoe is adapted and put onto the horse's hoof, and has for its object an organized machine in which all the necessary rolling and bending operations are performed without any loss time or motions, and the stock cut off rapidly from the bar fed in, and which shall, at the same time that it is effective in all its operations, be simple in its construction; and to these ends my invention consists in a machine having separate rolling and bending mechanisms, by means of which the shoe-blank is first rolled down and then bent around into shape, as will be hereinafter more fully explained; and my invention further consists in certain new devices and combinations used in a machine adapted to work on the plan just described.

To enable those skilled in the art to make and use my invention, I will proceed to describe my new machine, referring by letters to the accompanying drawing, in which—

Figure 1 is a front elevation; Fig. 2, a side elevation; Fig. 3, a top view; Fig. 4, a vertical section at line *x x*, Fig. 1; Fig. 5, a vertical section at the line *y y*, Fig. 2; and Figs. 6 and 7, detail views of the carrier mechanism.

In the several figures the same part will be found designated by the same letter of reference.

A is the main frame-work or body of the machine, in which are supported the table

B and all the working parts, as will be directly explained. C and D are the upper, and E F the lower, rolls of the two sets of rolling dies for shaping the straight blank, and are respectively on the shafts G and H, which are geared together by gears I I and J J, so that the shaft H is driven from the shaft G. This last-named may either have the motive power applied to one end directly, or through the medium of a counter-shaft and driving-pinion, K. The table B, as shown, is arranged so that its top surface lies about in a plane passing between the points of contact of the upper and lower rods.

a is a hole in the front cross-piece of the frame, through which the stock is fed in the usual manner to the machine, and at the inner end of which is a cut-off plate or die-plate, *b*, against which works the cutting-off die *c*, which moves back and forth past the feed-hole and die-plate *b*. On each side of the cut-off and about in line with the rolls is a feeder, L, (and M,) which is periodically moved longitudinally in one direction by means of the roll or rotatory disk C or D through the medium of a pin or lug, *d*, projecting from said disk, which engages with a projection at 1 on the rear end of the feed-bar, and is moved back when released from said lug *d* by means of a spring, *e*.

The cut-off die *c* is secured on the surface of a carriage, N, which has a reciprocatory movement in suitable bearings, effected by two inclines or cams, O P, (on the lower rolls,) which act alternately upon the two arms or projecting stands *f g* of the carriage N. This carriage has an arm or stand, *h*, projecting downward from it, which is coupled by means of a wrist-pin, *i*, to the slotted arm Q of a rock-shaft, R, and through this medium of connection the said carriage imparts to the said shaft an intermittent oscillating motion, as and for purposes to be directly explained.

j is a stop, against which the end of the rod is thrust when fed into the machine to regulate the length of the blanks cut off.

The table B has grooves or depressions in it for the accommodation of the carriers *k*, and also grooves *l*, in which the blanks pass while going onto the said carriers. S are plates, covering the grooves *l* part way during the length of the latter. T U are the formers, and

V V and W W the forming-cams of the bending mechanism.

$m m$ are two vertical bars, which are each connected by a cross-frame at its lower end to a bar, $n n$, and these bars $m m$ and $n n$ serve to move the formers T U up and down. Each of the bars m has a rack on it, into which meshes a toothed sector, X, (on the rock-shaft,) through which it is driven, and each of the bars n is provided on each of its edges with teeth, which mesh into and drive pinions $o p$ on shafts $q r$, which drive the rotary cams V and W. Each of the formers or benders T U is composed of two parts.

The shank t of the inner part is free to move longitudinally in the former-carriage u . (See Fig. 5.) It is provided with pins on either side, which pass into grooves 2 3 of a stationary casing, and the shank v of the outer part passes and moves freely through the shank t , and is provided with pins, which run in grooves 4 5. The former, with its carriage u , is moved up and down. Its parts are moved in and out by the cam-grooves 2 3 and 4 5, in a manner and for purposes to be presently explained. The carrier-frames k , which receive and carry to the bending mechanisms the rolled blanks, are so hung as to vibrate freely on centers or studs in bearings at 6 7, and each one is provided with a pinion, into which meshes a sector, 8, the lever or arm 9 of which projects out at the side of the machine, and is acted upon (in a manner to be explained) by a finger, 10, projecting from and rotated by the shaft H. Each of the said carrier-frames is provided with a rod, a^2 , passing down to a spring, b^2 , and immediately below each carrier-frame is located an inclined receiving table or chute, w , onto which the finished shoes fall, and from which they slide off to any suitable receptacle.

As is clearly shown, the upper rolls, C D, are formed with tongues, which work in grooves in the circumference of the lower rolls, E F, and on each of said upper rolls is a removable die, c^2 , (see Fig. 4,) of the proper shape to induce the required form to be imparted to the blank previous to its being bent around into the horseshoe shape.

d^2 (see Fig. 4) are adjusting or centering shoes. They are so arranged and formed that when the rolled blank is carried up by the carrier k , its ends of the blank pass in between the flaring opposite faces of said shoes, and the blank is by them moved endwise, (should it not be in the right position,) to insure its being placed centrally beneath the bender or former.

Each of the carrier-frames k is provided with a mechanism (actuated by inclines and stops on the frame and table) by means of which the blank, after it passes onto said carrier, is there clamped, and by which the blank is afterward released and deposited and held beneath the former or bender until the bending mechanism has gripped it.

As the two carriers and bending mechan-

isms are duplicates, I will describe the mechanism of one, from which description both will be comprehended.

Each arm of the carrier k (see Figs. 6, 7) is formed with a shoulder or projection at 1, and is provided with a sliding rod, 2, which is held out by a spring, 3. To this rod 2 is pivoted one end of a piece, 4, which is held in its normal position by a spring, 5, and which is cut out so as to leave a projection at 6, which, together with the shoulder 1, constitutes the clamp for holding the blank.

On the end of rod 2 is a rounded head, which comes in contact, when the carrier descends into the table B, with an incline or cam-shaped lug, a^4 , in said table, by means of which the rod 2 is forced in, (in the direction indicated by the arrow, Fig. 6,) and held in such position until the carrier is lifted away from the table.

S' is a vibratory arm, which is pivoted to k , and is moved by the plate 4. Its office is to push the blank home into place beneath the bender, as will be presently explained.

In the drawing the dotted lines at A^4 , Fig. 3, indicate a bar of iron, such as fed into the machine to make horseshoes, and which I have about square, and very nearly or just about the size in cross-section of the heel of the shoe to be made.

The operation of the several parts of the machine will be understood from the following explanation in connection with what I have already said of the several parts.

The motive power being applied, and the machine put in motion or set running, the bar is fed, as usual, into the machine through the hole a until its end strikes the gage or stop j , and is cut off each time as the carriage N moves back and forth. At each motion of the cut-off the blank is carried along to one of the feeders L M, which then moves in with it to the rolls, which roll the blank out and discharge it in the groove l under plate S, until a second one is rolled out by the same set of rolls, when the first one is pushed along by the second on to the carrier k , the clamping-jaws of which are open.

The carrier k then grips and lifts the blank, carries it up, and delivers it to the bending mechanism, which bends the rolled blank into the proper curved form and gives the finishing shape to it, discharging it onto the chute w .

While this operation is being performed by one set of rolls, carrier, and bending mechanism on one side of the machine, a similar operation is being performed on another blank by the other set of rolls, carrier, and bending mechanism; the operations, however, of feeding in a blank, rolling, carrying up, and bending being performed, not simultaneously, but in succession on the different sides of the machine—that is to say, just as a blank is rolled through by one set of rolls a blank is fed in to be rolled by the other set of rolls.

It will be understood that while the carriers k rest in the table their clamping-jaws are

open to receive the blanks fed in by the rolls, and that so soon as said carriers begin to ascend, their rod-heads 2 are relieved from the inclines a^4 , and the spring 3 forces said rod outward, carrying with it the piece 4, which clamps the blank between its shoulder 6 and the shoulder 1 of the carrier-bar.

When the carrier reaches its destination with the blank the rounded heads of rods 2, coming in contact with the inclined faces of lugs, are forced inward and the blank released from the clamps; and at the same time the ends of the pieces 4, coming against the frame of the machine, are pressed outward and swivel the pivoted pieces or plates S' , so that they press the blanks home against the face of the former-block u .

In the operation of the bending mechanism, which commences just as the blank is deposited and held as just explained, the former first descends to the blank; then its two parts close together, so that the blank is gripped between them, and carry the blank down between the rotary cams V W.

As the blank is bent around the former it is also pressed into complete shape. After the former has descended to its lowest limit of motion the two parts open or separate, and the finished shoe falls out.

The opening and closing of the parts of the former to gripe the blank and allow the finished shoe to drop out, as just explained, are effected by means of the cam-grooves 2 3 and 4 5, already mentioned.

In the details of construction many changes may be made without departing from the spirit of my invention; and in lieu of using the duplication of rolling and bending mechanisms, with their feeding devices, in connection with a double-acting cut-off device, only one-half of my machine may be used; but I deem the whole arrangement, operating as described, to be the best.

I do not wish to be understood as claiming, broadly, the rolling and bending devices; but,

Having fully explained the construction and operation of my new machine for making horseshoes, what I claim therein as new, and desire to secure by Letters Patent, is—

1. A machine constructed and operating substantially in the manner described, in which the blank is first shaped or rolled out straight and then bent up and finished.

2. The employment, in combination with a double-acting cutting-off device, of two feeding mechanisms for alternately operating to carry to the rolling-dies the blanks cut off successively.

3. The cut-off described, so arranged and

operating as to also perform the functions of a carrier to and guide in the feeder, as described.

4. The automatic carrier for taking the rolled blank to the bending mechanism constructed and operating substantially as described.

5. A bending and finishing mechanism composed of a former having a reciprocatory motion, in combination with two oscillatory cams, between which said former passes, the whole constructed and arranged to operate in substantially the manner described.

6. A machine having two sets of rolling-dies and two bending mechanisms, the whole constructed as shown, and so arranged and operating that while one set of dies is preparing a blank for the bending mechanism which works in conjunction with said set of dies, the bending mechanism which works in conjunction with the other set of dies shall be bending up and finishing a blank, as hereinbefore set forth.

7. A compound reciprocatory former constructed and operated as described, so that while its parts move together during the bending operation, they separate and close for gripping and releasing the blank and finished shoe, as hereinbefore described.

8. The employment, in combination with the bending mechanism, of centering or registering gages d^2 , for insuring the proper placement of the blank, substantially as set forth.

9. The combination of the pinions O P and their racks n with the driving-racks m and double vibratory sector X, substantially as and for the purpose set forth.

10. The combination, with the bending mechanism described and cutting-off mechanism, of a single rock-shaft, R, which is actuated by the cutting-off mechanism and operates the bending mechanism.

11. In combination with the carrier which feeds the rolled blank to the bender, an automatic locking device for clamping the blank and insuring its delivery to the bending mechanism, as described.

12. In combination with a vibratory carrier, k , provided with a pinion, s^2 , a sector-arm, 9, and finger 10, for lifting and holding up said carrier, and a suitable spring device for insuring its descent.

In testimony whereof I have hereunto set my hand and seal this 14th day of February, 1870.

J. H. SNYDER. [L. s.]

Witnesses:

J. McINTIRE,
T. B. BEECHER.