

C. ROTHENBERGER.
TRIP HAMMER.

(Application filed July 30, 1898.)

(No Model.)

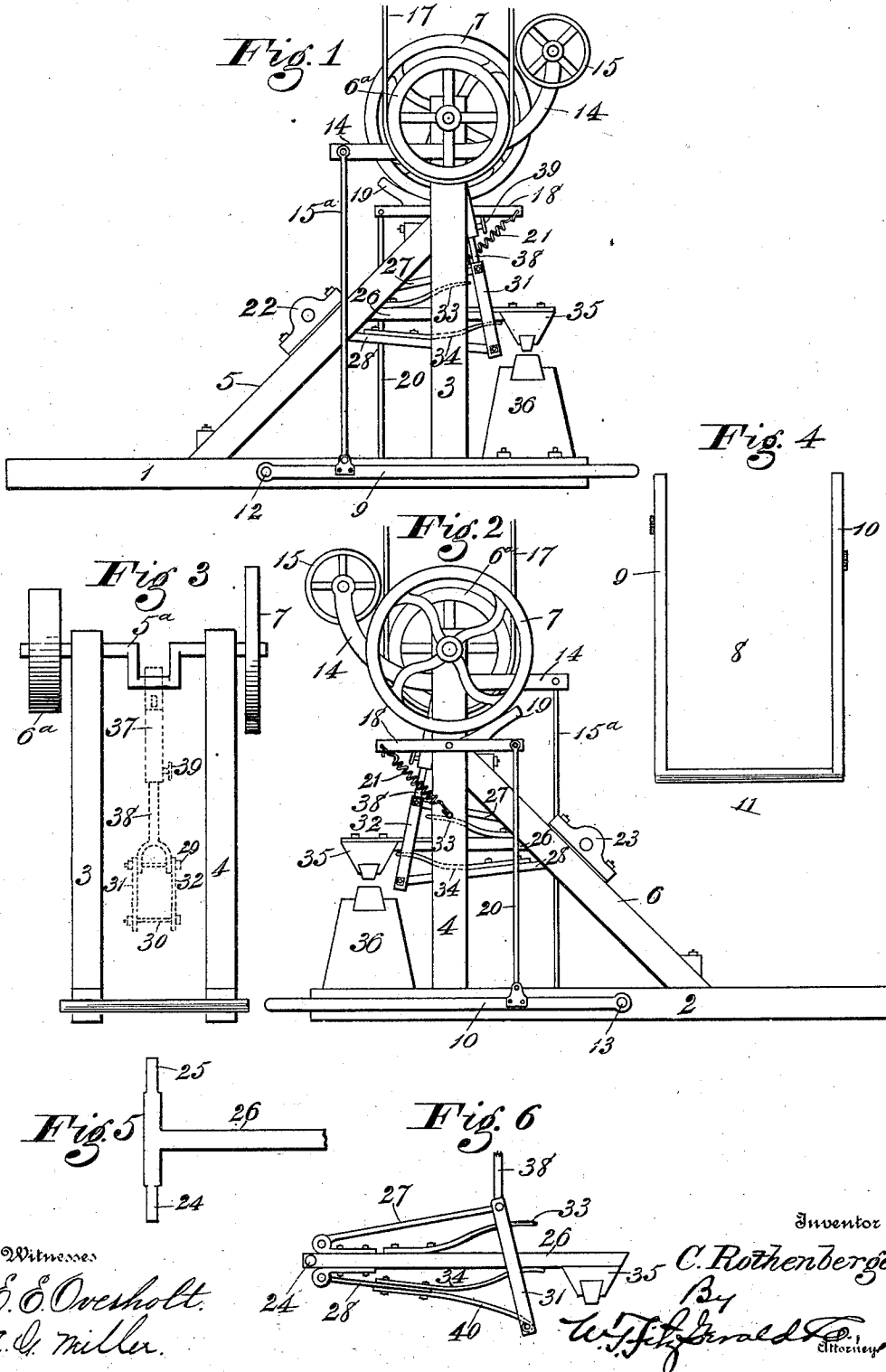

Witnesses
E. C. Overholt.
A. Q. Miller.

Inventor
C. Rothenberger
 By
W. J. ...
 Attorney

UNITED STATES PATENT OFFICE.

CHRISTIAN ROTHENBERGER, OF TRIPP, SOUTH DAKOTA.

TRIP-HAMMER.

SPECIFICATION forming part of Letters Patent No. 647,525, dated April 17, 1900.

Application filed July 30, 1898, Serial No. 687,292. (No model.)

To all whom it may concern:

Be it known that I, CHRISTIAN ROTHENBERGER, a citizen of the United States, residing at Tripp, in the State of South Dakota, have
5 invented certain new and useful Improvements in Trip-Hammers; and I do hereby declare the following to be a full, clear, and exact description of the invention, such as will enable others skilled in the art to which it
10 appertains to make and use the same.

My invention has relation to trip-hammers, the object being to provide a hammer which will be simple, durable, and economical in construction and which will reliably perform
15 the work required of such a device with less strain upon the working parts thereof than in other hammers now in common use.

The construction, operation, and advantages of my improved hammer will be pointed
20 out in the appended specification and claims and illustrated in the accompanying drawings, forming a part of this application, in which—

Figure 1 is a side elevation of my hammer.
25 Fig. 2 is a side elevation showing the opposite side thereof. Fig. 3 is a front view of the frame with the crank-shaft and the wheels carried thereby in position. Fig. 4 is a top plan of the foot-lever, while Fig. 5 is a top
30 plan of the hammer-handle; and Fig. 6 is a view of a slightly-varied form of hammer-operating mechanism.

Referring to the drawings, the frame of my machine consists of the horizontally-disposed
35 beams 1 and 2, lying parallel to each other, the vertical beams 3 and 4, erected thereupon, and the braces 5 and 6.

Mounted in suitable bearings at the top of the beams or posts 3 and 4 is the crank-shaft
40 5^a, carrying at one end thereof the driving-pulley 6^a and at the other the fly-wheel 7. The foot-lever 8, substantially U-shaped, is composed of the parallel sides or sections 9
45 and 10 and the transverse section 11. Said lever is attached to the frame by the bolts 12 and 13. The sides 9 and 10 of the lever lie along the outside of the beams 1 and 2, respectively, and are parallel thereto.

Near the upper end of the post 3, pivotally
50 secured thereto, is the bent lever 14, the upper end of which carries the small wheel 15, which may be denominated the "belt-tightener."

The other end of the lever 14 is connected to section 9 of the foot-lever by means of the rod 15^a. The driving-pulley 6^a is connected to
55 the driving-shaft or whatever other power is employed to operate the hammer by the loose belt 17.

Pivotaly attached to post 4 is the brake-lever 18, carrying the brake 19. This lever
60 18 is connected at one end with the section 10 of the foot-lever, the rod 20 forming the connecting-link. To the other end of the lever 18 is attached the spring 21, the other end of said spring being firmly secured to post 4.
65 This spring operates to hold the brake 19 normally in contact with the fly-wheel 7. When it is desired to start the machine, the free end 11 of the foot-lever is pressed downward. This overcomes the force of the spring
70 21 and moves the brake 19 out of engagement with the fly-wheel 7. The foot-lever being constructed as illustrated and described, it follows that the two sides thereof must always
75 move together, either up or down, simultaneously. Hence when this lever is moved downwardly one side of it operates to release the brake from the fly-wheel, as already stated, while simultaneously with this the other end
80 operates to force the wheel 15 against the belt 17, which takes up the slack in the belt, and thereby operatively connects the pulley 6^a with the line of shafting or other propelling power, which at once sets the machine in motion.
85

When it is desired to stop the machine, all that is necessary is to remove the foot from the foot-lever, whereupon the spring 21 instantly acts to bring the brake 19 into engagement with the fly-wheel, and through in-
90 termediate connection it also operates on lever 14 to bring pulley 15 out of engagement with the driving-belt 17, which at once loosens the belt, so that motion is no longer transmitted thereby. Hence it will be seen that by
95 operating the foot-lever one of two results takes place—either the belt is tightened and the brake simultaneously removed to start the machine or, on the other hand, the machine is locked and the belt loosened simul-
100 taneously therewith to stop the machine.

Suitably mounted upon the braces 5 and 6 are the bearings 22 and 23, adapted to respectively receive the ends 24 and 25 of the

transverse bar of the hammer-handle 26, Fig. 5. Connected to the hammer-handle 26, near the inner end thereof, either by pivots or strong hinges are the flat bars 27 and 28, the former attached to the upper and the latter to the lower side of said handle. These bars are pivotally connected to each other at their outer ends by the bolts 29 and 30 and the side straps 31 and 32.

Between the upper bar 27 and the handle I locate the strap-spring 33, while between the lower bar and said handle I locate the spring 34. These springs serve as cushions when the machine operates to suddenly raise and lower the hammer as it delivers blows upon the anvil 36. The hammer, through its handle-bars 27 and 28, is connected with the crank-shaft through the mediation of the pitman 37 and the extension-shank 38. The pitman 37 is provided with a socket, into which the extension-shank 38 telescopes, being held in any position desired by the set-screw 39. The lower end of said shank is U-shaped.

Fig. 6 shows a slight modification in my method of further cushioning my hammer as it is elevated preparatory to delivering a blow. I accomplish this by shortening the lower handle-bar 28 and substituting for the cut-away portion thereof the spring 40. It will be seen from the foregoing that I have provided means which greatly relieve the working parts of the machine from the strain that would ordinarily be imposed thereupon by sudden

jerks, &c. Consequently my machine will last longer, will do better work, and be less liable to breakage and strain than the machines now in ordinary use.

Having thus fully described the principles of my invention and illustrated means whereby the same may be applied to practical use, I yet do not wish to be limited to the exact showing made, but desire protection in all that comes clearly within the scope of my invention.

What I claim as new, and desire to secure by Letters Patent, is—

1. In a trip-hammer, a pivoted hammer, handle-bars pivoted thereto, straps connecting the outer ends of said bars and cushioning devices carried by said handle and means to operate the hammer, as set forth.

2. In a trip-hammer, a pivoted hammer, handle-bars pivoted thereto, a leaf-spring on the top of the hammer-handle, a double leaf-spring on the under side of said handle, lower spring being pivoted to said handle, straps connecting the outer ends of the handle-bars and means to operate said hammer, as set forth.

In testimony whereof I affix my signature in presence of two witnesses.

CHRISTIAN ROTHENBERGER.

Witnesses:

WILL A. GRAHAM,
J. A. SMETHERS.