



- (51) International Patent Classification:
A61F 13/44 (2006.01) A61B 17/50 (2006.01)
- (21) International Application Number:
PCT/US2013/062033
- (22) International Filing Date:
26 September 2013 (26.09.2013)
- (25) Filing Language: English
- (26) Publication Language: English
- (30) Priority Data:
61/712,640 11 October 2012 (11.10.2012) US
- (71) Applicant: RUSH UNIVERSITY MEDICAL CENTER
[US/US]; 1653 W. Congress Parkway, Chicago, IL 60612 (US).
- (72) Inventor: BYRNE, Richard, W.; 1725 W. Harrison St., Suite 1115, Chicago, IL 60612 (US).
- (74) Agents: MARTIN, Alice, O. et al.; Barnes & Thornburg LLP, P.O. Box 2786, Chicago, IL 60690-2786 (US).
- (81) Designated States (unless otherwise indicated, for every kind of national protection available): AE, AG, AL, AM,

AO, AT, AU, AZ, BA, BB, BG, BH, BN, BR, BW, BY, BZ, CA, CH, CL, CN, CO, CR, CU, CZ, DE, DK, DM, DO, DZ, EC, EE, EG, ES, FI, GB, GD, GE, GH, GM, GT, HN, HR, HU, ID, IL, IN, IS, JP, KE, KG, KN, KP, KR, KZ, LA, LC, LK, LR, LS, LT, LU, LY, MA, MD, ME, MG, MK, MN, MW, MX, MY, MZ, NA, NG, NI, NO, NZ, OM, PA, PE, PG, PH, PL, PT, QA, RO, RS, RU, RW, SA, SC, SD, SE, SG, SK, SL, SM, ST, SV, SY, TH, TJ, TM, TN, TR, TT, TZ, UA, UG, US, UZ, VC, VN, ZA, ZM, ZW.

- (84) Designated States (unless otherwise indicated, for every kind of regional protection available): ARIPO (BW, GH, GM, KE, LR, LS, MW, MZ, NA, RW, SD, SL, SZ, TZ, UG, ZM, ZW), Eurasian (AM, AZ, BY, KG, KZ, RU, TJ, TM), European (AL, AT, BE, BG, CH, CY, CZ, DE, DK, EE, ES, FI, FR, GB, GR, HR, HU, IE, IS, IT, LT, LU, LV, MC, MK, MT, NL, NO, PL, PT, RO, RS, SE, SI, SK, SM, TR), OAPI (BF, BJ, CF, CG, CL, CM, GA, GN, GQ, GW, KM, ML, MR, NE, SN, TD, TG).

Published:
— with international search report (Art. 21(3))

(54) Title: ANCHORING FOR NON-RETAINABLE FOREIGN OBJECTS

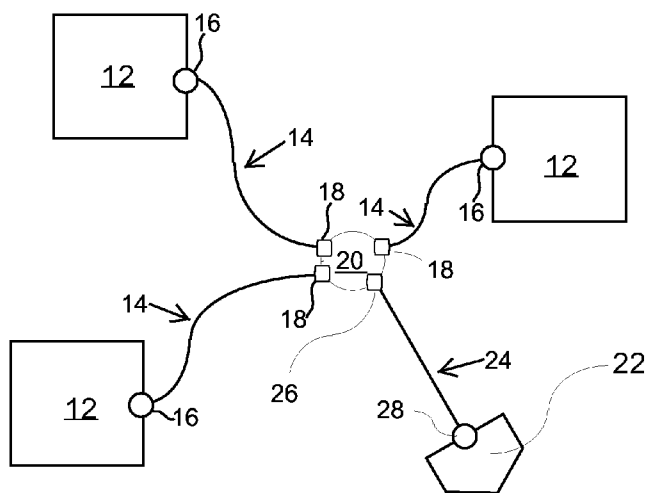

FIG 1

(57) Abstract: A kit and/or method for use during surgery is configured to decrease the risk of accidental retention of foreign objects, such as surgical items or medical devices, used in surgery inside of a patient after the surgery is completed. Specifically, illustrative kits may include, but not be limited to, a combination of one or more foreign objects, an anchoring member attached to a point outside of the patient or surgical field, and at least one or more connection members connecting the foreign objects to the anchoring member. Illustrative methods may include, but not be limited to, anchoring one or more foreign object by one or more connection members, wherein a first end of each connection member is attached to the foreign object, and a second end of each connection member is attached to a junction member; attaching the junction member to an anchoring member; and attaching the anchoring member to a structure that is outside the patient or surgical field.

WO 2014/058630 A1

ANCHORING FOR NON-RETAINABLE FOREIGN OBJECTS**BACKGROUND**

[0001] A kit and/or method for use during surgery is described herein. The kit and/or method is configured to decrease the risk of accidental retention of foreign objects, such as surgical items or medical devices, used in surgery inside of a patient after the surgery is completed. Specifically, illustrative kits and/or methods may include, but not be limited to, a combination of one or more medical devices, surgical items and/or an anchoring member.

[0002] Surgical items such as sponges or stimulation tags may be used inside of or placed on a patient where applicable during a surgical procedure. Similarly, medical devices used during surgery are also used inside of a patient during a surgical procedure. Currently, such surgical items or medical devices are not anchored or connected to a fixed point outside of the patient. These items or devices may be lost or misplaced in the surgical field due to inadvertent and undesirable movement or obscuring caused by fluids or other tissue effluents, such as smoke during laser ablation. Consequently, this may lead to the foreign objects being accidentally retained within the patient's body after surgery. The risk of a retained foreign object such as a surgical item or medical device may be eliminated by the kit and/or method disclosed herein. Specifically, the kit may include an anchoring member to connect such foreign objects to a point outside the patient's body. Further, the foreign objects may be packaged into a traceable, easy to use, standardized kit with such an anchoring member.

[0003] Safe, reliable and simple methods for using surgical items or medical devices without the risk of the foreign objects being retained inside the patient are beneficial.

SUMMARY OF THE DISCLOSURE

[0004] A kit for use during surgery that decreases the risk of foreign objects, such as surgical items or medical devices, used in surgery being retained inside the patient after surgery is disclosed. Such a kit may include:

- (a) one or more foreign objects;
- (b) at least one anchoring member; and

(c) one or more connection members connecting the foreign objects to the anchoring member.

[0005] A method of preventing foreign objects, such as surgical items or medical devices, from remaining inside a patient after undergoing a surgical procedure is disclosed. Such a method may comprise:

(a) anchoring each foreign object to a connection member, wherein a first end of the connection member is attached to the foreign object, and a second end of the connection member is attached to a junction member;

(b) attaching the junction member to an anchoring member; and

(c) attaching the anchoring member to a structure that is outside the patient's body and is stable until detached.

BRIEF DESCRIPTION OF THE DRAWINGS

[0006] FIG. 1 shows an illustrative embodiment of a kit of the present disclosure, the kit including one or more non-retainable surgical sponges coupled together by a junction member that is further coupled to an anchoring member.

[0007] FIG. 2 shows another illustrative embodiment of a kit of the present disclosure, the kit including one or more non-retainable surgical stimulation tags anchored by a junction member that further is coupled to an anchoring member.

[0008] FIG. 3 shows another illustrative embodiment of a kit of the present disclosure, the kit including one or more non-retainable, non-descript foreign object anchored by a junction member that further is coupled to an anchoring member.

[0009] FIG. 4 shows another illustrative embodiment of a kit of the present disclosure, the kit including one or more non-retainable, non-descript foreign object anchored directly to an anchoring member.

[00010] Other objects, features and advantages of the disclosed devices and methods will become apparent from the following detailed description. It should be understood the detailed description and the specific examples, while indicating preferred embodiments, are given by way of illustration only, because various changes and modifications within the spirit and scope of the invention will become apparent to those skilled in the art from the detailed description.

DETAILED DESCRIPTION

- [00011] A kit for use during surgery that decreases the risk of foreign objects, such as surgical items or medical devices, used in surgery being retained inside the patient after surgery is disclosed. In illustrative embodiments, the kit includes multiple components for use during surgery, including one or more foreign objects, an anchoring member, and/or a junction member. The kit is configured to allow all of the components to be attached together to ensure that the foreign objects used inside of a patient during surgery are anchored together to a point outside of the surgical field, and therefore can be removed together after the surgery is complete to avoid unintentionally retaining any foreign objects inside the patient after surgery.
- [00012] The components of the present invention may include a wide variety of items and foreign objects used during a surgical procedure. For instance, the medical devices may include, but are not limited to, sponges or tags. The surgical items may include, but are not limited to, protecting sheets, barriers, cotton balls, gauze, and surgical protectors. The anchoring members may include, but are not limited to, clips, paper fasteners, claw mechanisms, clamps, and loop-and-hook mechanisms. The junction members may include, but are not limited to, a flexible ring, tube or bar.
- [00013] The foreign objects are configured to include a connection member, such as a suture, string, electronic cord or wire, to allow the components to be attached to the junction member and/or anchoring member. The connection members may be radio-opaque. Alternatively, the connection members may be made of the same material as the foreign objects or may be integrally made with the foreign objects. Alternatively, the connection members may be structurally separate or an extension of the foreign objects. In illustrative embodiments, the connection members may be attached to the foreign objects by any known means, such as surgical staples, zip ties, knots and/or soldering. The connection member may also be attached to the foreign objects by sterile glue.
- [00014] In addition to coupling the foreign objects to a junction member and/or anchoring member, the connection members may also be used to couple a junction member to an anchoring member. In illustrative embodiments, the connection members are configured to provide a point of connection or attachment between

the medical devices, surgical items, the anchoring members and/or junction members.

[00015] In use, the kit and its components provide an effective means of ensuring that any foreign objects, such as surgical items or medical devices, used during surgery are not inadvertently left inside a patient once the surgery is complete. The user of the kit, for example, a surgeon or surgical staff, places the kit in the area in and around the surgical field and arranges the foreign objects in appropriate locations. Appropriate locations for these foreign objects may be predetermined by the surgeon and the surgical procedures. For instance, tags may be placed in areas of the patient that should not be targeted for the surgical procedure and must be avoided. Sponges may be placed, for example, in areas where bodily fluids could obscure the surgeon's field of view and removal of the fluids is necessary. The medical devices or surgical items may be connected to the junction member, or directly to the anchoring member, either prior to or after placement of the medical devices or surgical items in the surgical field.

[00016] The anchoring member of the kit may attach to a variety of locations. For example, the anchoring member may attach to either to a surgical drape that overlays and protects the surgical field, or to some other convenient point on the patient or in the surgical area. The anchoring member may also be attached to a point on the skull or other body part of the patient. The anchoring member may also be attached to scalp hemostasis clips positioned on the patient. The anchoring member may also be attached to various objects around the surgical area, such as, but not limited to, an overhead light, bed rail, or surgical cart. The anchoring member should be attached to something outside of the patient and is preferably out of the way of the surgical work.

[00017] The junction member of the kit is configured to provide an optional central point of connection for all surgical items and medical devices. In illustrative embodiments, the surgical items and medical devices are coupled together around a single junction member, and the single junction member is then coupled directly to the anchoring member. The junction member, through a single connection member connecting the junction member to the anchoring member, permits a single connection to the anchoring member even though multiple surgical items and medical devices may be anchored by the anchoring member. In other embodiments, each surgical item and medical device may be individually coupled

to the anchoring member by multiple connection members. Any number of foreign objects may be coupled to one junction member, including but not limited to a number that is complementary to certain surgical procedures, such as 3, 5 or 10 foreign objects. Moreover, multiple kits, or multiple anchoring mechanisms within one kit, may be used throughout the entire surgical area.

[00018] The process of coupling the foreign objects to the junction member, and/or the junction member to the anchoring member, may include a variety of coupling techniques. For instance, the foreign objects may be first placed in the surgical field or on the patient and then coupled to the junction member. Or the foreign objects may be manufactured as coupled to the junction member prior to surgery. Similarly, the junction member may be coupled to the anchoring member before or after the foreign objects are utilized during surgery. Other various processes are also envisioned.

[00019] The connection members of the components couple the components together and ensure that the foreign objects are ultimately linked (either directly or through the junction member) to the anchoring member outside of the patient's body. Therefore, it is important that the connection members remain intact during the entire surgical procedure. When possible, the connection members may be placed outside of the surgical field, or at least in locations that are not where the targeted surgery is being performed, when the patient is undergoing surgery. After the surgery is complete, the anchoring member may be released and the entire kit, including all foreign objects, such as medical devices or surgical items, and the anchoring member, may be removed. Prior to removal, a user such as a surgeon may perform a count of all foreign objects attached to the anchoring member to ensure all attached foreign objects used in the surgical field are not retained within the patient's body. Any combination of medical devices, surgical items and/or anchoring members may be used in a kit if necessary. Use of such kits during surgery decreases the risk of the individual attached foreign objects being lost or retained in the patient after surgery.

[00020] FIG. 1 illustrates one embodiment of a kit 10 of the present disclosure, the kit including anchored non-retainable surgical sponges 12. As illustrated, a plurality of sponges 12 (symbolized as squares) are individually attached to corresponding connection members 14 at a first end 16 of the connection members 14. A second, distal end 18 of the connection members 14 are attached to a

common junction member 20. Similarly, the common junction member 20 is attached to an anchoring member 22 by a corresponding connection member 24 at a first end 26 of the connection member 26, and a second end 28 of the connection member 24 is attached to the anchoring member 22.

[00021] FIG. 2 illustrates another embodiment of a kit 30 of the present disclosure, the kit 30 including anchored non-retainable surgical tags 32. As illustrated, the plurality of tags 32 (symbolized by circles) are individually attached to corresponding connection members 34 at a first end 36 of the connection members 34. A second, distal end 38 of the connection members 34 are attached to a common junction member 40. Similarly, the common junction member 40 is attached to an anchoring member 42 by a corresponding connection member 44 at a first end 46 of the connection member 44, and a second end 38a of the connection member 44 is attached to the anchoring member 42.

[00022] FIG. 3 illustrates another embodiment of a kit 50 of the present disclosure, the kit 50 including anchored non-retainable, non-descript foreign objects 52. As illustrated, a plurality of generic or non-descript foreign objects 52 (symbolized by circles) are individually attached to corresponding connection members 54 at a first end 56 of the connection members 54. A second, distal end 58 of the connection members 54 are attached to a common junction member 60. The common junction member 60 is attached to an anchoring member 62 by a separate connection member 64.

[00023] FIG. 4 illustrates an alternate embodiment of a kit 70 of the present disclosure, the kit 70 including anchored non-retainable, non-descript foreign objects 72. As illustrated, a plurality of generic or non-descript foreign objects 72 (symbolized by circles) are individually attached to corresponding connection members 74 at a first end 76 of connection members 74. A second, distal end 78 of connection members 74 are directly connected to an anchoring member 80. In this embodiment, no junction member is disclosed.

[00024] Although the instant invention describes embodiments of various kits 10, 30, 50 and 70, as illustrated in FIGS. 1-4, it is contemplated that the instant invention can be used to retain other types of surgical items or devices. Thus, the instant disclosure should not be read to limit the use of the instant invention to sponges, tags, other medical devices, or other surgical items s for use during surgery. Furthermore, the organization and type of the individual components of a

kit represent preferred embodiments and should not be read to limit the use of alternate configurations and types. One of ordinary skill in the art can discern, from the description of the instant invention, alternate embodiments contemplated by the inventors.

EXAMPLE

Examples presented are illustrative of the invention, and not limiting.

Example 1:

[00025] Cortical stimulation mapping tags may get lost in the surgical field during surgery. A kit of the present invention for a cortical mapping unit may include, for example, five colored plastic tags or discs of 1 cm diameter. The tags may be numbered and connected to individual connection members such as small caliber, flexible, radio-opaque strings. The connection members may, in turn, be connected to an anchoring member that is configured to grasp or clip onto a surgical drape. Alternatively, the anchoring member may be configured to anchor directly to a patient's skull.

[00026] Current cortical mapping tags are made ad hoc at individual institutions, are not anchored, and may be lost in the surgical field. This may lead to a retained component, such as the mapping tags, being left inside the patient's body on accident. A kit of the present invention that conforms to modern operating room requirements of traceable implants reduces the risk of any of the components, such as cortical stimulation mapping tags, getting lost in the surgical field and left in a patient's body unintentionally. Such a kit also brings components, such as mapping tags and other foreign objects, together into a traceable, easy to use, standardized kit.

CLAIMS:

1. A kit for use during surgery that decreases the risk that foreign objects used in surgery will be unintentionally retained inside the subject of the surgery, the device comprising:
 - (a) one or more foreign objects;
 - (b) an anchoring member, the anchoring member attached to a point outside of the subject of the surgery; and
 - (c) at least one or more connection members connecting the foreign objects to the anchoring member.
2. The kit of claim 1, wherein the foreign objects are medical devices or surgical items.
3. The kit of claim 2, wherein the foreign objects are surgical tags.
4. The kit of claim 1, wherein the connection members are integrally formed with the foreign objects.
5. The kit of claim 4, wherein the connection members are made of the same material as the foreign objects.
6. The kit of claims 5, wherein the connection members include a distal end spaced away from the foreign objects.
7. The kit of claim 1, wherein the foreign objects are connected to the anchoring member through both connection members and a junction member.
8. The kit of claim 7, wherein a connection member extends between the junction member and the anchoring member.
9. The kit of claim 7, wherein the junction member provides a single, central point of connection for all foreign objects.

10. The kit of claim 9, wherein the junction member is configured to be located within the surgical field during surgery.
11. The kit of claim 9, wherein the junction member is made of flexible material.
12. The kit of claim 11, wherein the junction member is a ring, bar or tube.
13. The kit of claim 1, wherein the anchoring member includes a clip, paper fastener, claw mechanism, clamp, or loop-and-hook mechanism.
14. A method of preventing foreign objects, such as medical devices and surgical items, from remaining inside a subject undergoing a surgical procedure, the method comprising:
 - (a) anchoring each foreign object by one or more connection members, wherein a first end of each connection member is attached to the foreign object, and a second end of each connection member is attached to a junction member;
 - (b) attaching the junction member to an anchoring member; and
 - (c) attaching the anchoring member to a structure that is outside the surgical field.
15. The method of claim 14, wherein any of the one or more connection members is a flexible suture, string, or wire.
16. The method of claim 14, wherein any of the one or more connection members is radio-opaque.
17. The method of claim 14, wherein any of the one or more connection members is integrally connected to the foreign objects.
18. The method of claim 17, wherein the second end of any of the one or more connection members is removably attached to the junction member.

19. The method of claim 18, wherein any one of the one or more connection members is removable from the junction member independent of the other connection members.

20. The method of claim 14, wherein the junction member is attached to the anchoring member by a second set of one or more connection members.

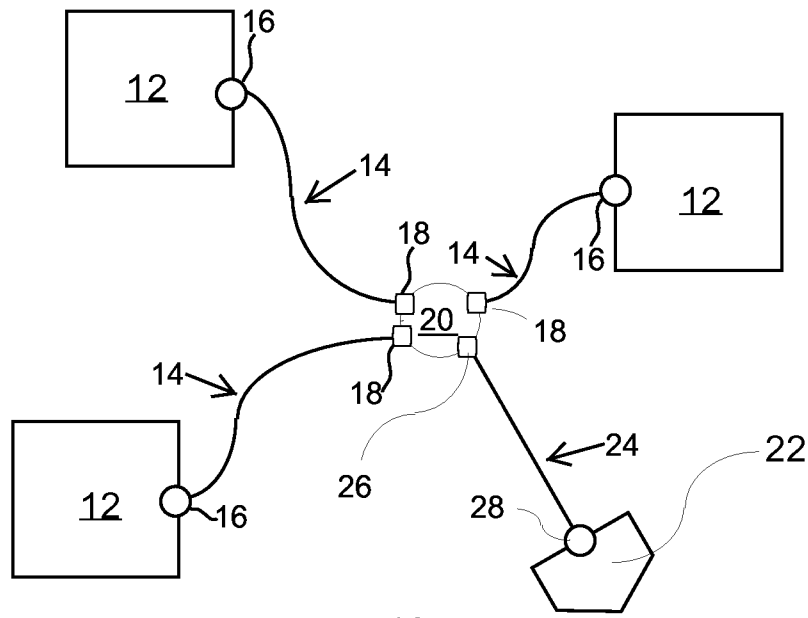

-10-

FIG 1

3/4

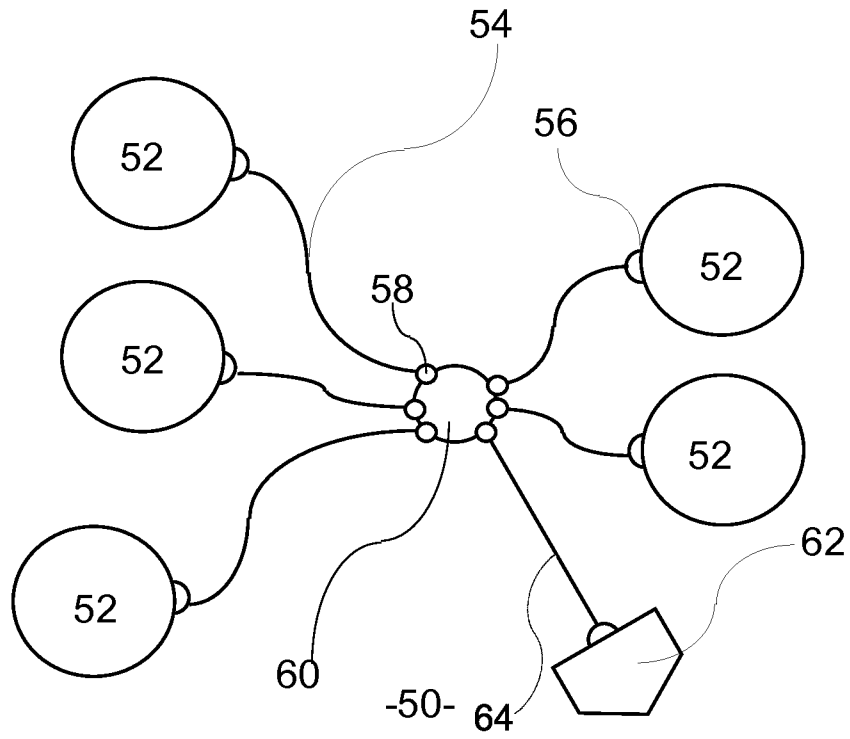

FIG 3

4/4

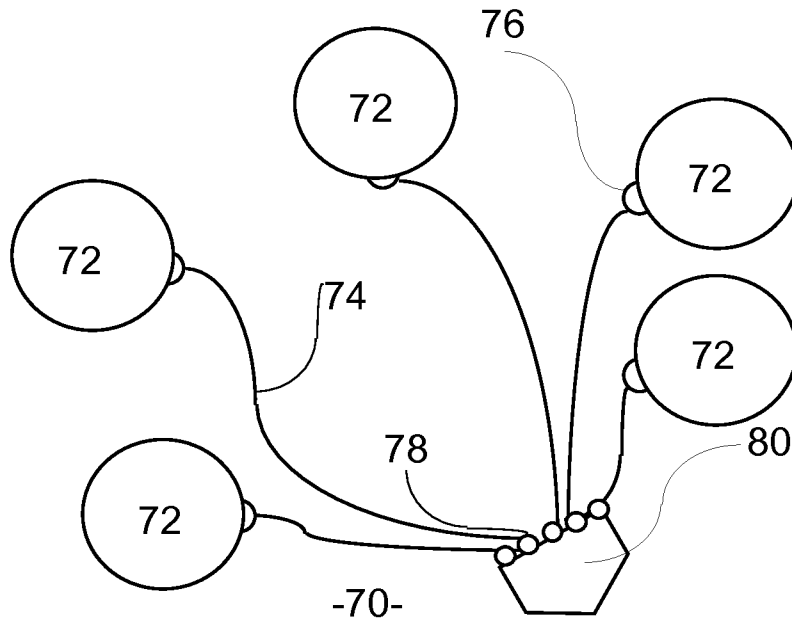

FIG 4

INTERNATIONAL SEARCH REPORT

International application No
PCT/US2013/062033

A. CLASSIFICATION OF SUBJECT MATTER
INV. A61F13/44 A61B17/50
ADD.
According to International Patent Classification (IPC) or to both national classification and IPC

B. FIELDS SEARCHED
Minimum documentation searched (classification system followed by classification symbols)
A61B A61F

Documentation searched other than minimum documentation to the extent that such documents are included in the fields searched

Electronic data base consulted during the international search (name of data base and, where practicable, search terms used)
EPO-Internal, WPI Data

C. DOCUMENTS CONSIDERED TO BE RELEVANT

Category*	Citation of document, with indication, where appropriate, of the relevant passages	Relevant to claim No.
X	US 5 203 767 A (CLOYD DAVID W [US]) 20 April 1993 (1993-04-20) column 2, line 25 - column 3, line 19; figures 1-3	1-20
X	----- US 3 630 202 A (SMALL SIDNEY ROBERT) 28 December 1971 (1971-12-28) column 2, line 29 - column 3, line 40; figures 1-3	1-13
X	----- US 5 370 656 A (SHEVEL ELLIOT [ZA]) 6 December 1994 (1994-12-06) column 3, line 47 - column 4, line 53; figures 7-10	1-3,13, 14
	----- -/--	

Further documents are listed in the continuation of Box C.

See patent family annex.

* Special categories of cited documents :

- "A" document defining the general state of the art which is not considered to be of particular relevance
- "E" earlier application or patent but published on or after the international filing date
- "L" document which may throw doubts on priority claim(s) or which is cited to establish the publication date of another citation or other special reason (as specified)
- "O" document referring to an oral disclosure, use, exhibition or other means
- "P" document published prior to the international filing date but later than the priority date claimed

- "T" later document published after the international filing date or priority date and not in conflict with the application but cited to understand the principle or theory underlying the invention
- "X" document of particular relevance; the claimed invention cannot be considered novel or cannot be considered to involve an inventive step when the document is taken alone
- "Y" document of particular relevance; the claimed invention cannot be considered to involve an inventive step when the document is combined with one or more other such documents, such combination being obvious to a person skilled in the art
- "&" document member of the same patent family

Date of the actual completion of the international search 13 December 2013	Date of mailing of the international search report 20/12/2013
Name and mailing address of the ISA/ European Patent Office, P.B. 5818 Patentlaan 2 NL - 2280 HV Rijswijk Tel. (+31-70) 340-2040, Fax: (+31-70) 340-3016	Authorized officer Moers, Roelof

INTERNATIONAL SEARCH REPORT

International application No
PCT/US2013/062033

C(Continuation). DOCUMENTS CONSIDERED TO BE RELEVANT		
Category*	Citation of document, with indication, where appropriate, of the relevant passages	Relevant to claim No.
X	US 2011/077682 A1 (GREGORY KENTON W [US] ET AL) 31 March 2011 (2011-03-31) paragraph [0047] - paragraph [0048]; figure 3 -----	1,14
X	US 5 074 840 A (YOON INBAE [US]) 24 December 1991 (1991-12-24) column 3, line 12 - column 4, line 58; figures 1-4 -----	1,14
X	US 5 112 325 A (ZACHRY KATHY W [US]) 12 May 1992 (1992-05-12) column 4, line 31 - column 6, line 42; figures 1-5 -----	1,14
X	US 2011/066124 A1 (SHAO WEIRU [US]) 17 March 2011 (2011-03-17) paragraph [0028]; figures 1-6 -----	1,14

INTERNATIONAL SEARCH REPORT

Information on patent family members

International application No PCT/US2013/062033

Patent document cited in search report	Publication date	Publication date	Patent family member(s)	Publication date
US 5203767	A	20-04-1993	NONE	

US 3630202	A	28-12-1971	NONE	

US 5370656	A	06-12-1994	AU 6242894 A	14-09-1994
			US 5370656 A	06-12-1994
			WO 9419050 A1	01-09-1994

US 2011077682	A1	31-03-2011	AU 2010246025 A1	17-11-2011
			CA 2760201 A1	11-11-2010
			EP 2427157 A1	14-03-2012
			JP 2012525930 A	25-10-2012
			US 2011077682 A1	31-03-2011
			WO 2010129587 A1	11-11-2010

US 5074840	A	24-12-1991	US 5074840 A	24-12-1991
			US 5827215 A	27-10-1998
			US 6248088 B1	19-06-2001

US 5112325	A	12-05-1992	NONE	

US 2011066124	A1	17-03-2011	US 2011066124 A1	17-03-2011
			WO 2012054464 A2	26-04-2012
