



(19) **United States**

(12) **Patent Application Publication**
Shaolian et al.

(10) **Pub. No.: US 2006/0271164 A1**

(43) **Pub. Date: Nov. 30, 2006**

(54) **IMPLANTABLE VASCULAR GRAFT**

now Pat. No. 6,197,049, which is a continuation-in-part of application No. 09/210,280, filed on Dec. 11, 1998, now Pat. No. 6,187,036.

(76) Inventors: **Samuel M. Shaolian**, Newport Beach, CA (US); **Frank M. Zeng**, Irvine, CA (US)

Publication Classification

Correspondence Address:
KNOBBE MARTENS OLSON & BEAR LLP
2040 MAIN STREET
FOURTEENTH FLOOR
IRVINE, CA 92614 (US)

(51) **Int. Cl.**
A61F 2/90 (2006.01)
(52) **U.S. Cl.** **623/1.16; 623/1.35**

(57) **ABSTRACT**

Disclosed is a tubular endoluminal vascular prosthesis, useful in treating, for example, an abdominal aortic aneurysm. The prosthesis comprises a self-expandable wire support structure having a tubular main body support and first and second branch supports. The support structure may include sliding links to permit flexibility while maintaining patency of the central lumen. The branch supports may articulate with the main body to permit the branches to pivot laterally from the axis of the main body throughout a substantial range of motion. Exoskeleton components or barbs may be provided to resist migration and endoleaks.

(21) Appl. No.: **11/417,926**
(22) Filed: **May 3, 2006**

Related U.S. Application Data

(63) Continuation of application No. 10/764,991, filed on Jan. 26, 2004, which is a continuation-in-part of application No. 09/728,582, filed on Dec. 1, 2000, now abandoned, which is a continuation-in-part of application No. 09/251,363, filed on Feb. 17, 1999,

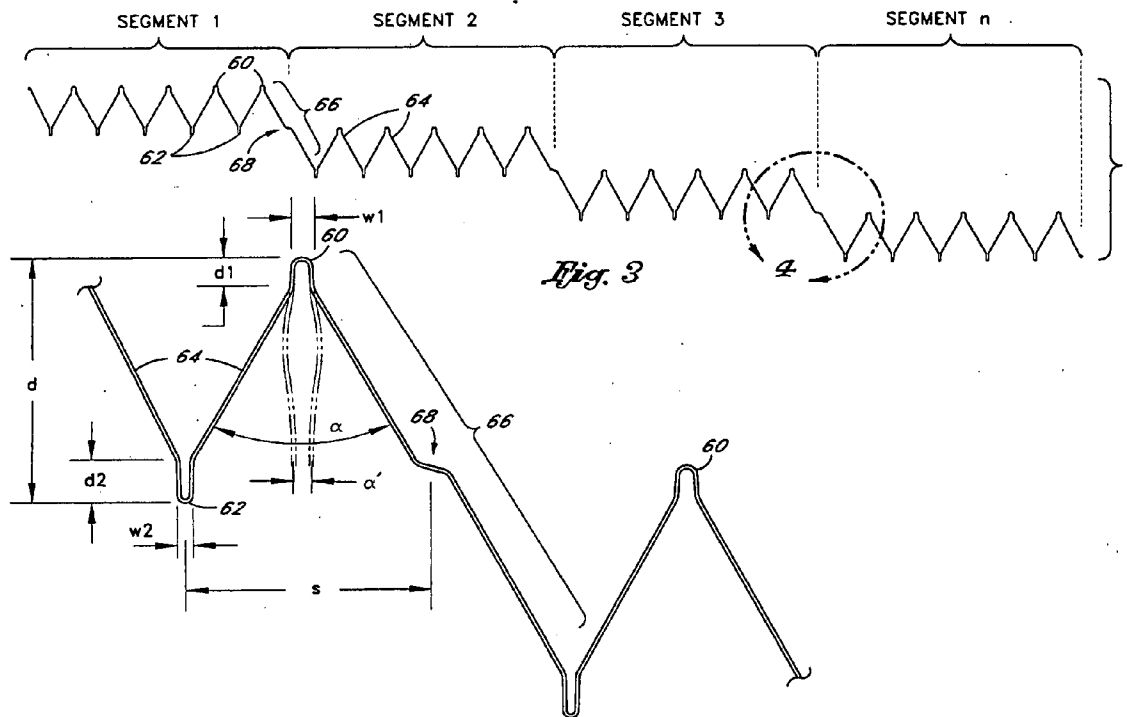

Fig. 1

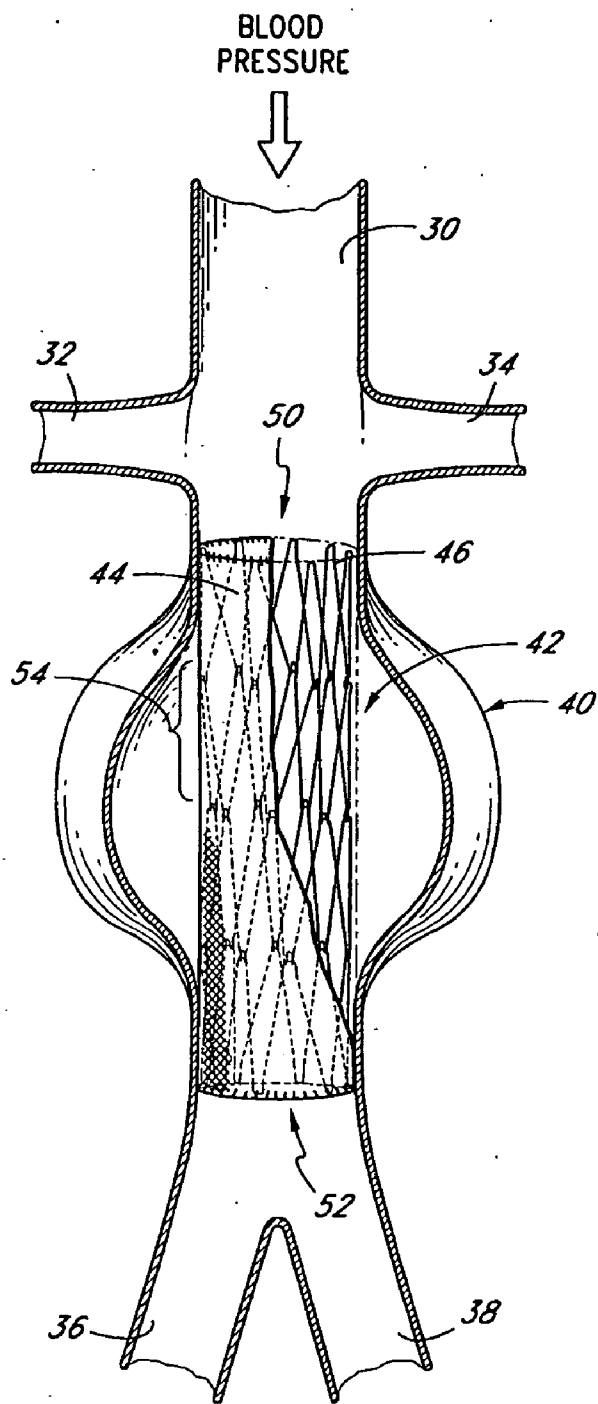
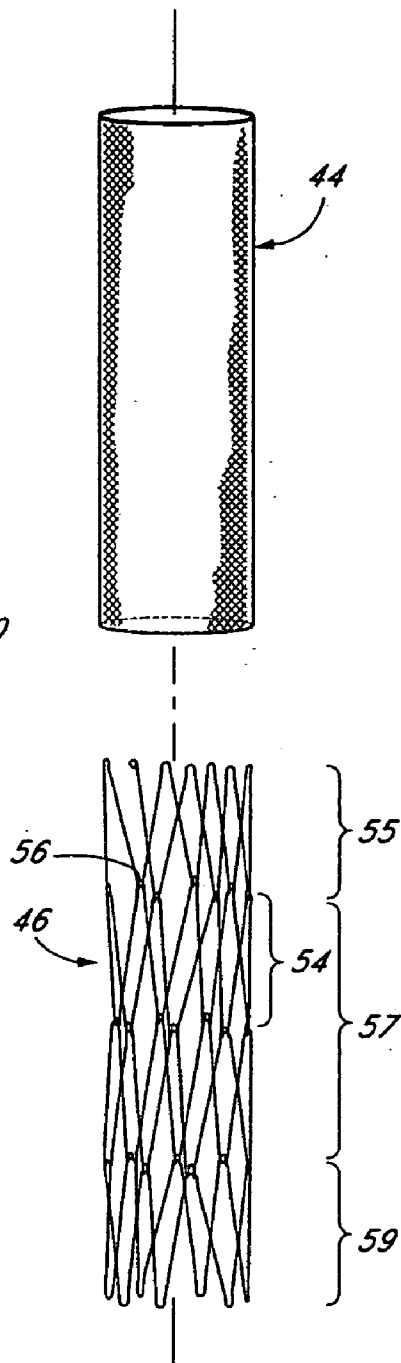

Fig. 2



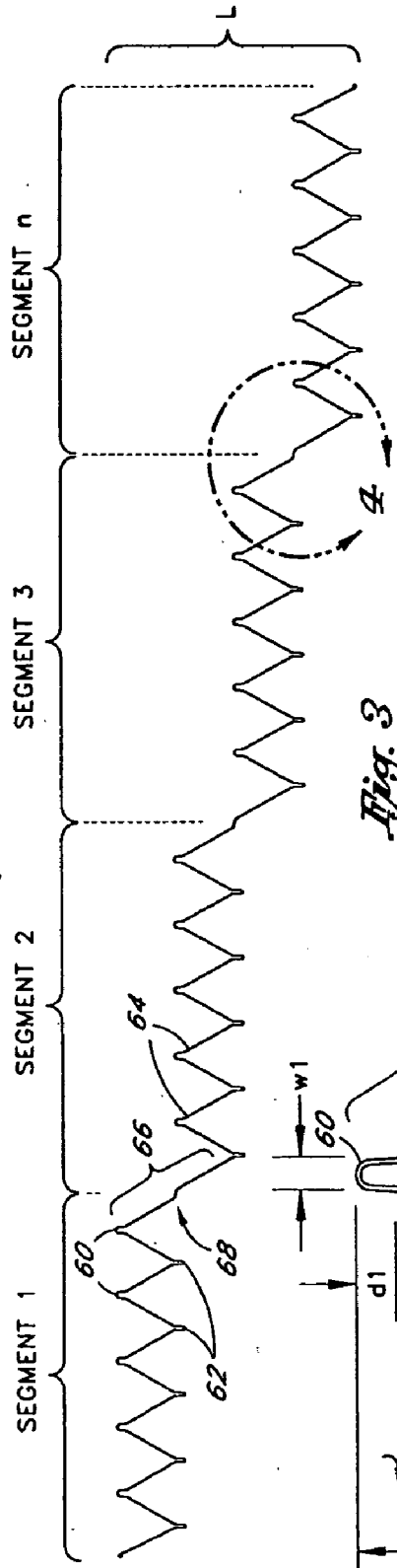

Fig. 3

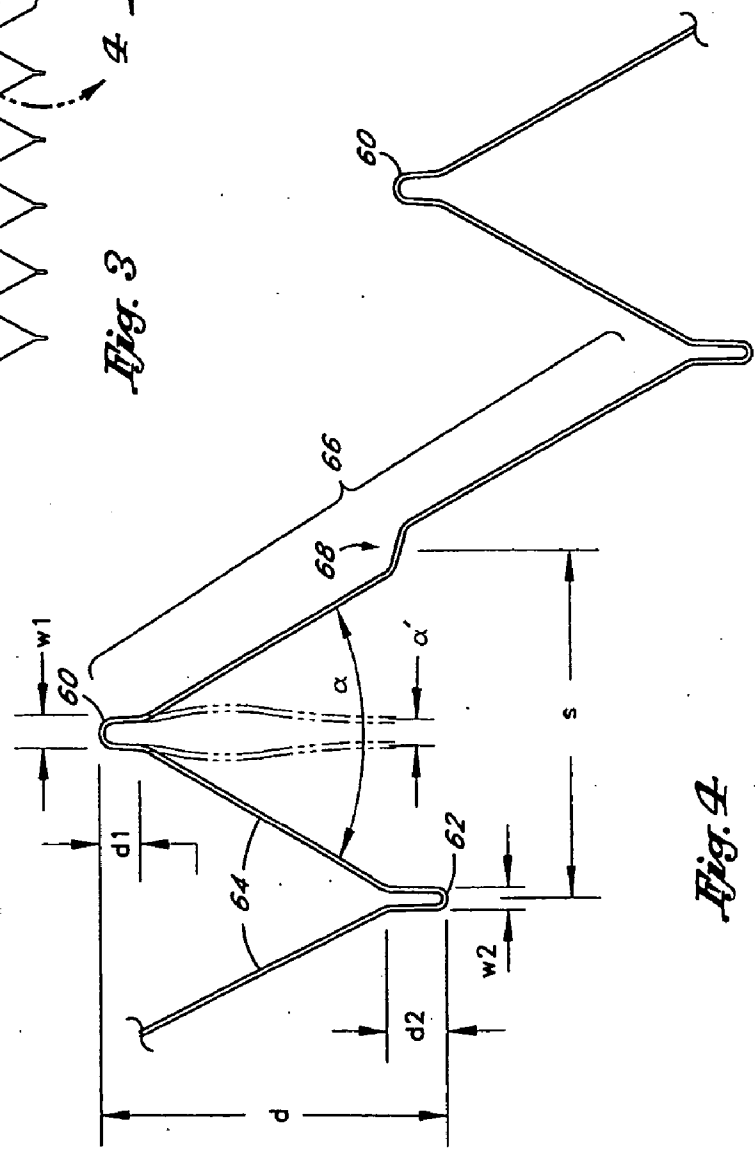

Fig. 4

Fig. 5

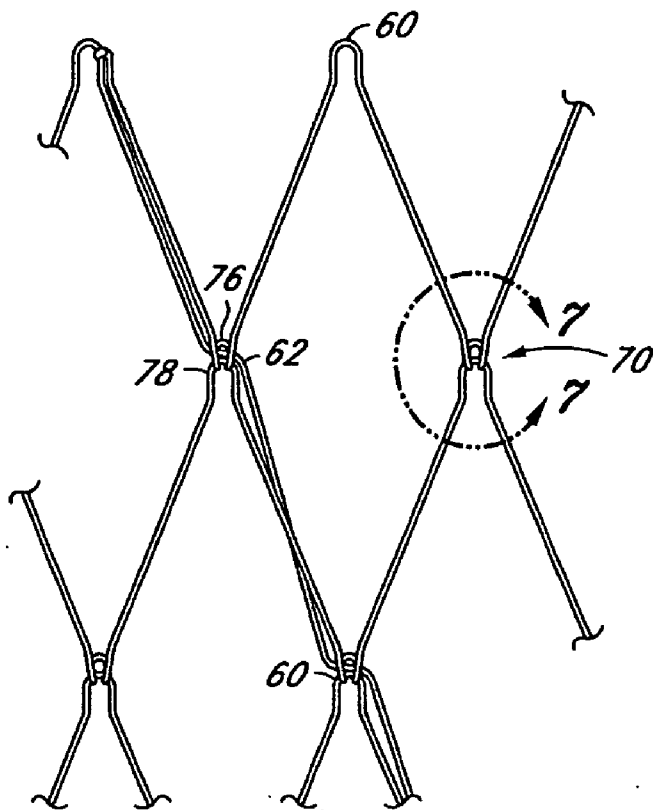

Fig. 6

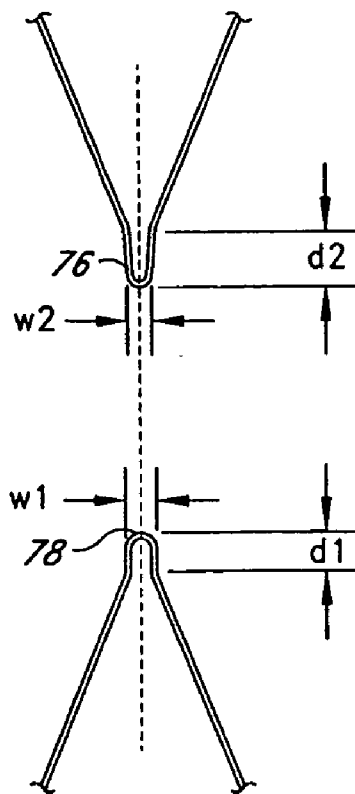

Fig. 6A

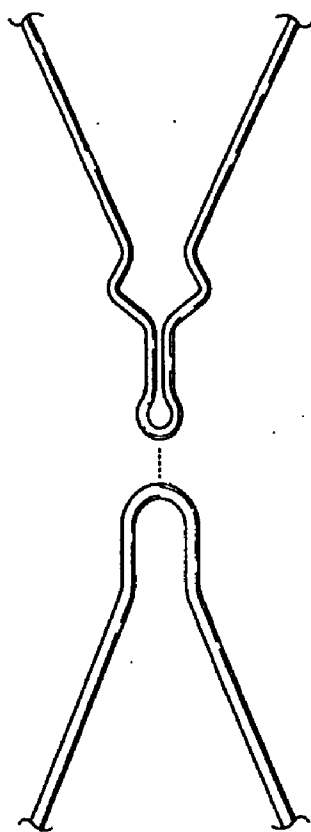

Fig. 7A

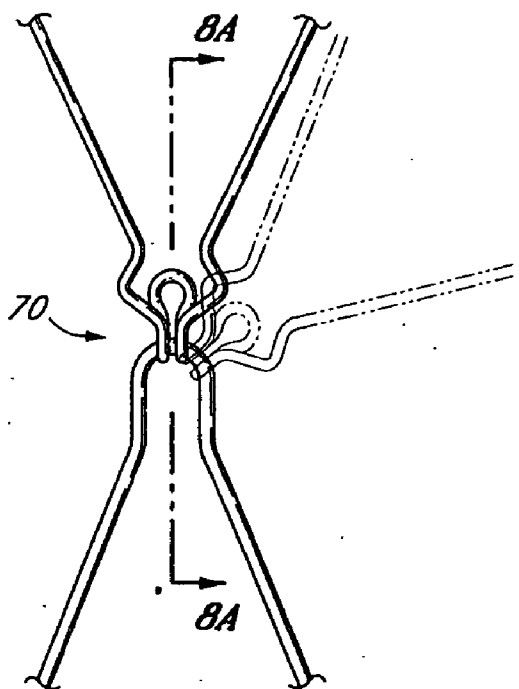

Fig. 8A

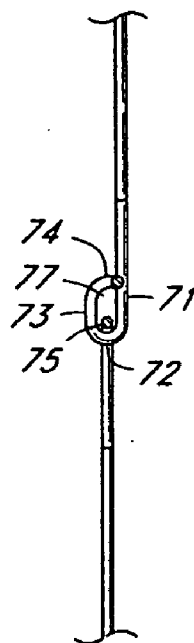

Fig. 7

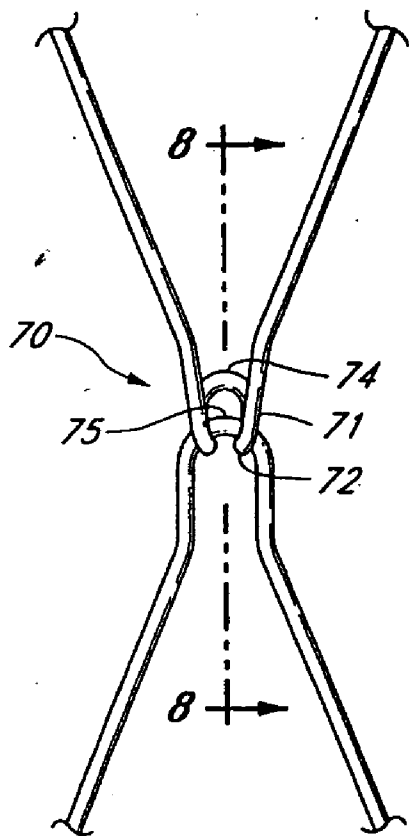

Fig. 8

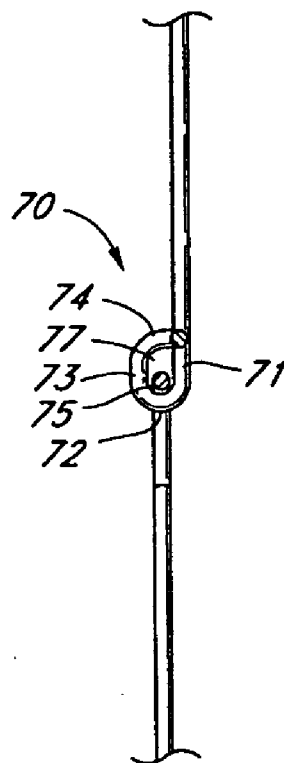

Fig. 7B

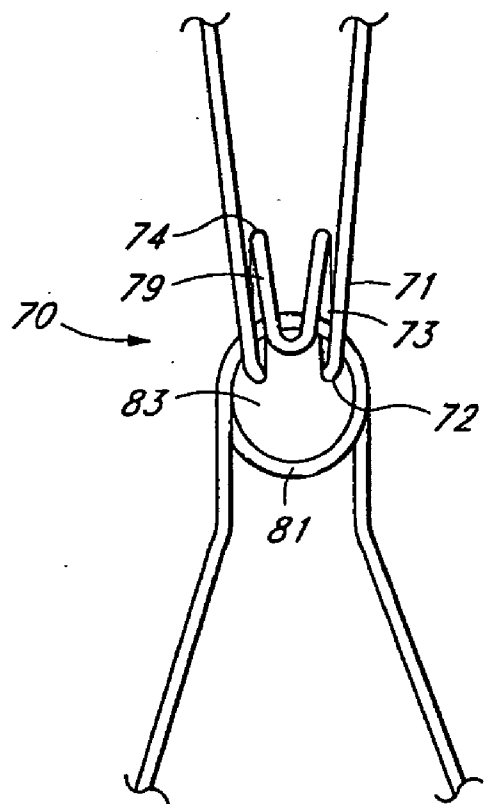

Fig. 8B

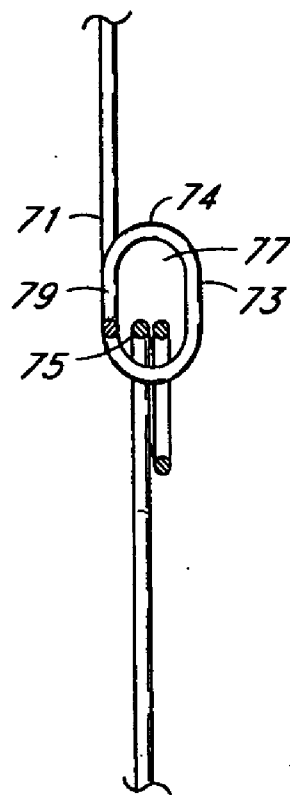

Fig. 7C

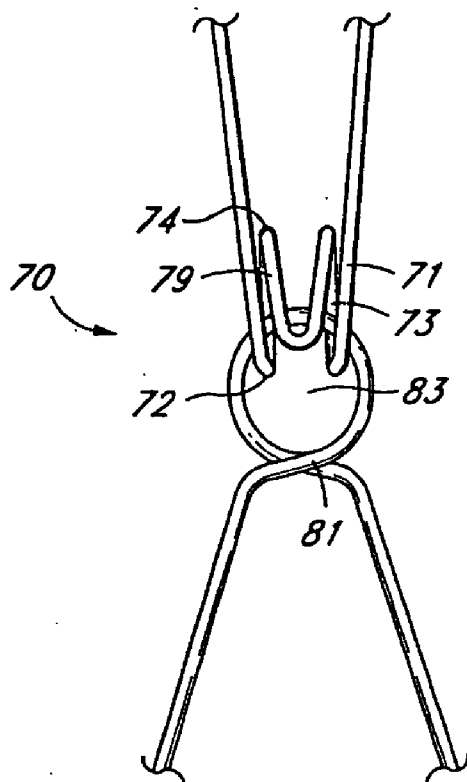

Fig. 7D

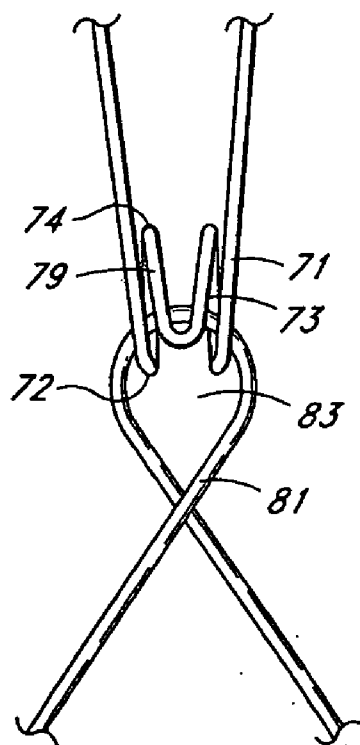

Fig. 9

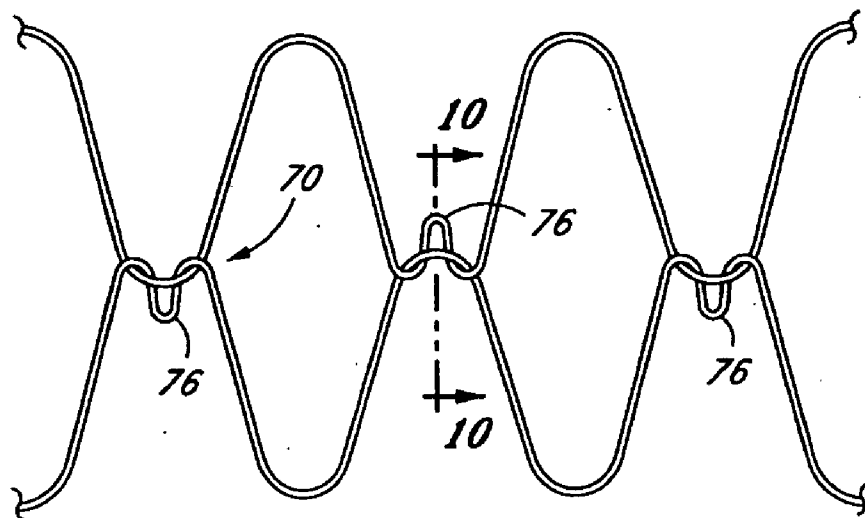

Fig. 10

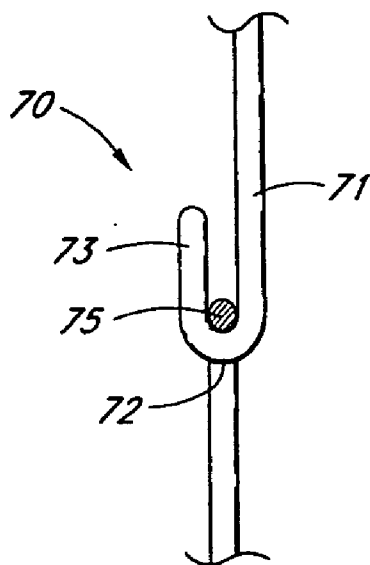

Fig. 11

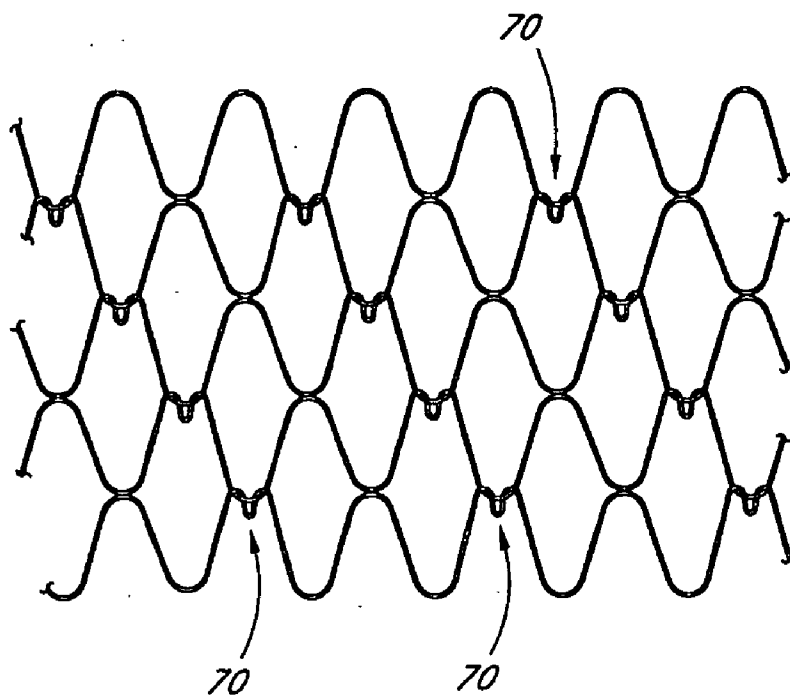

Fig. 12

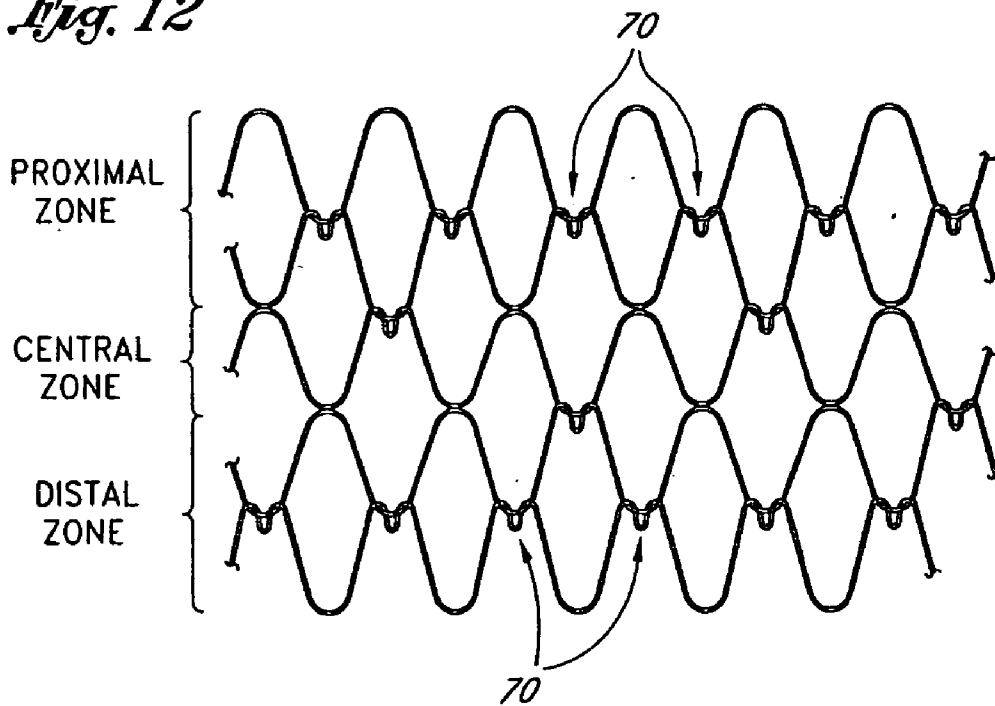

Fig. 12A

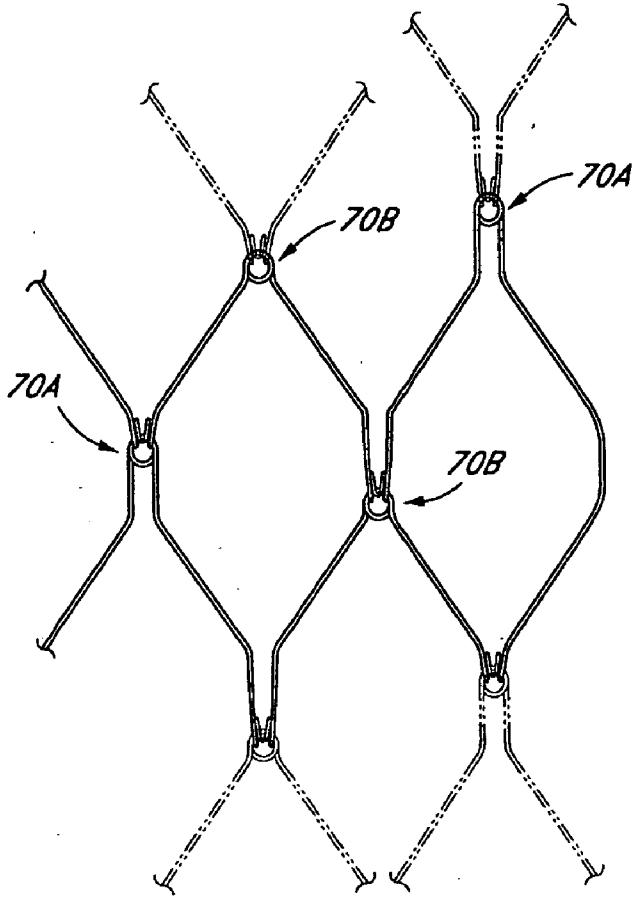

Fig. 12B

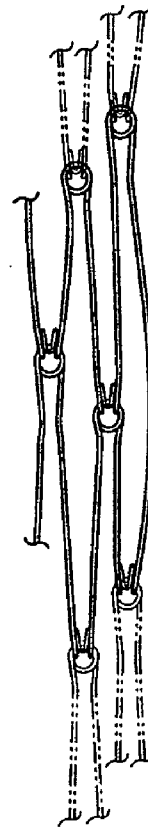

Fig. 12C

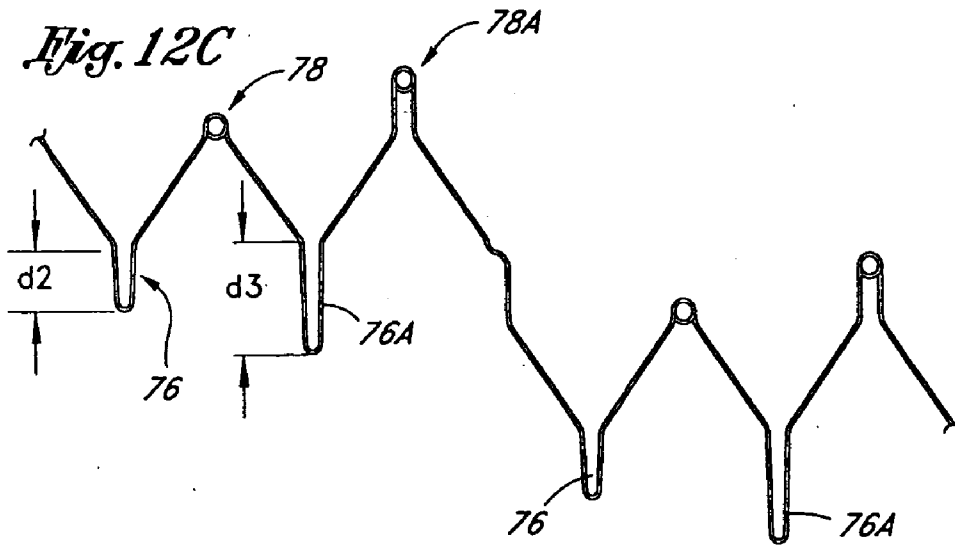

Fig. 13

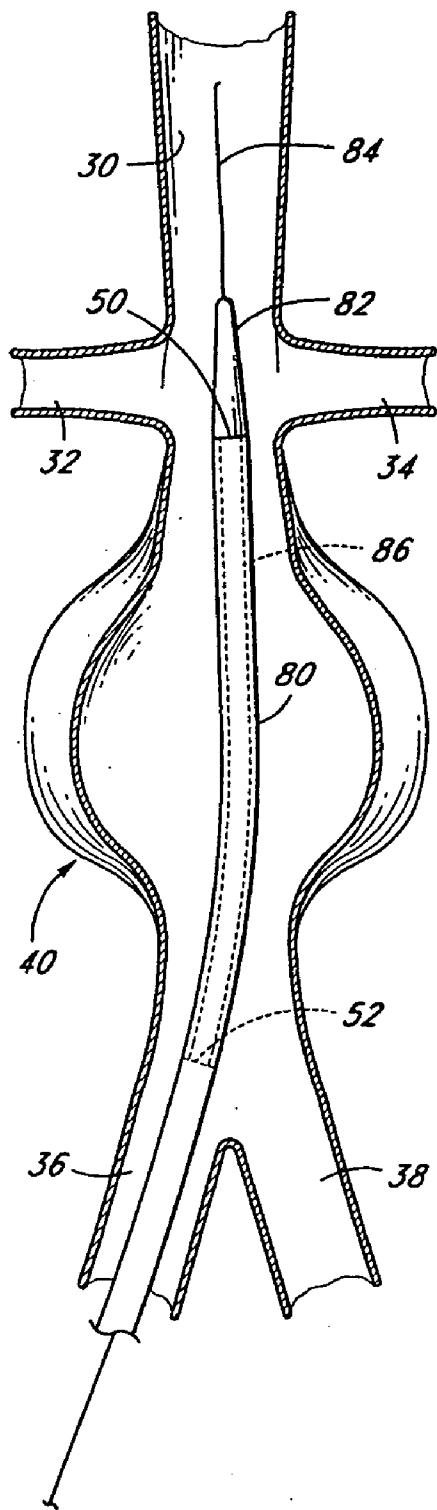

Fig. 14

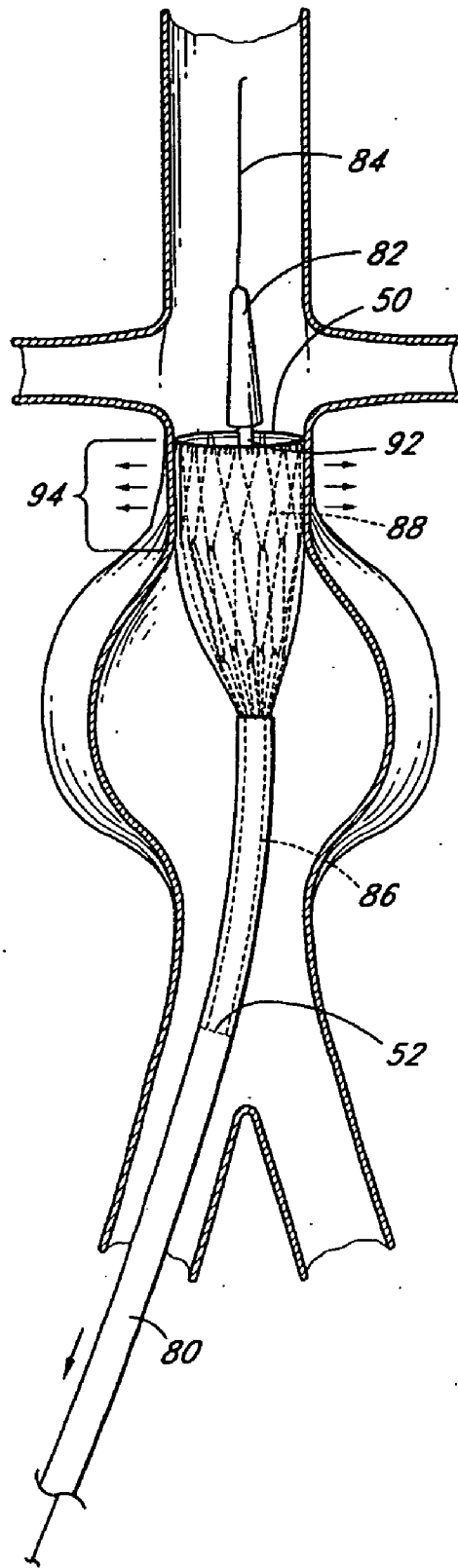

Fig. 15

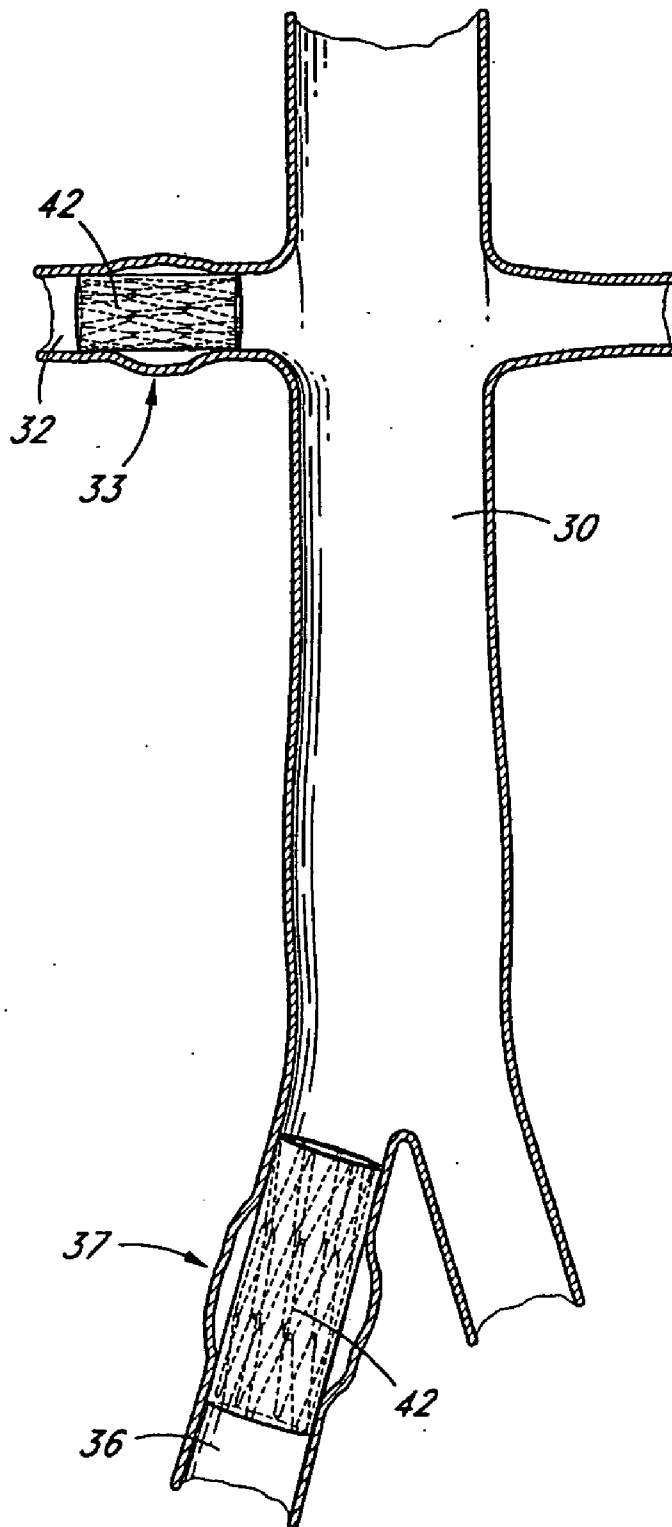

Fig. 16

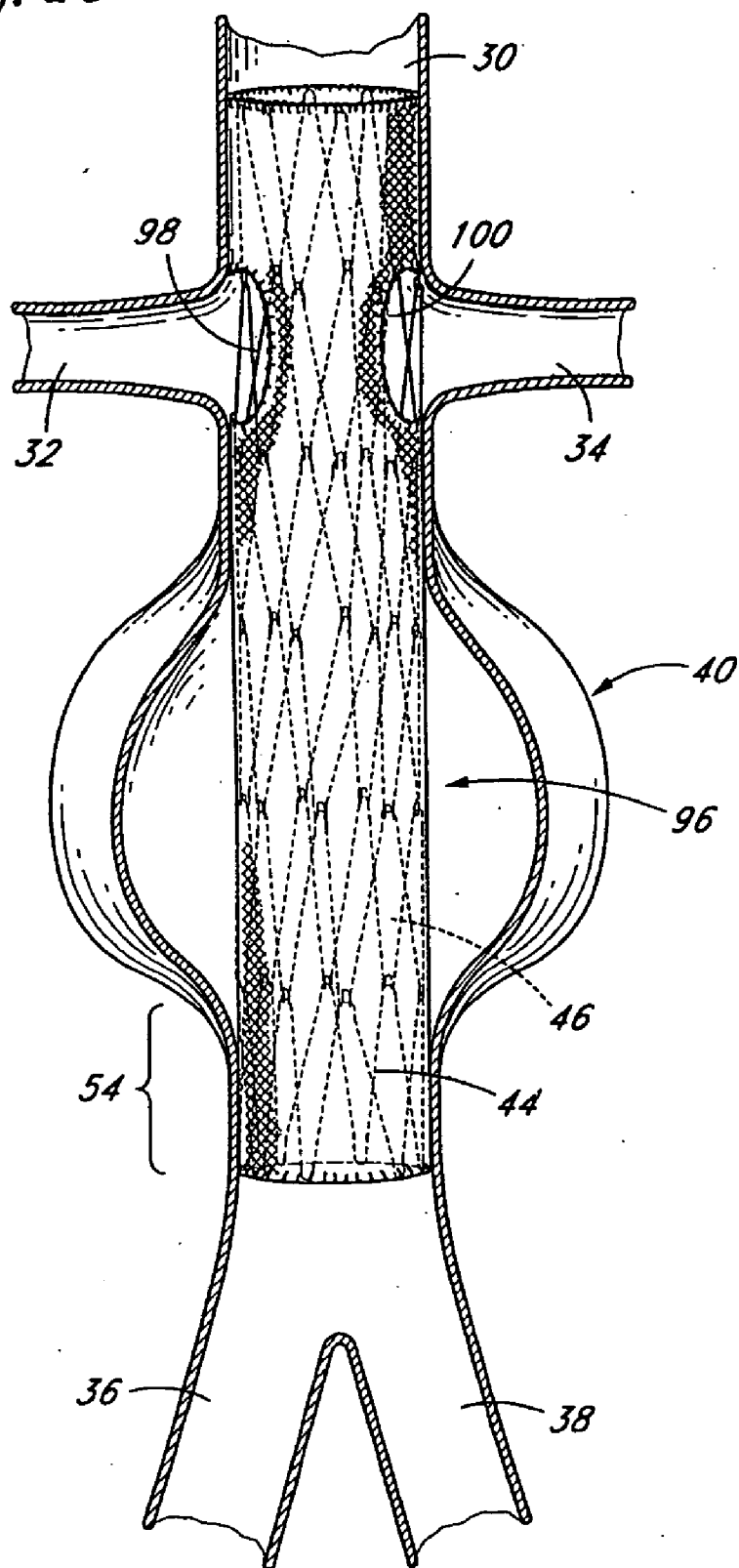
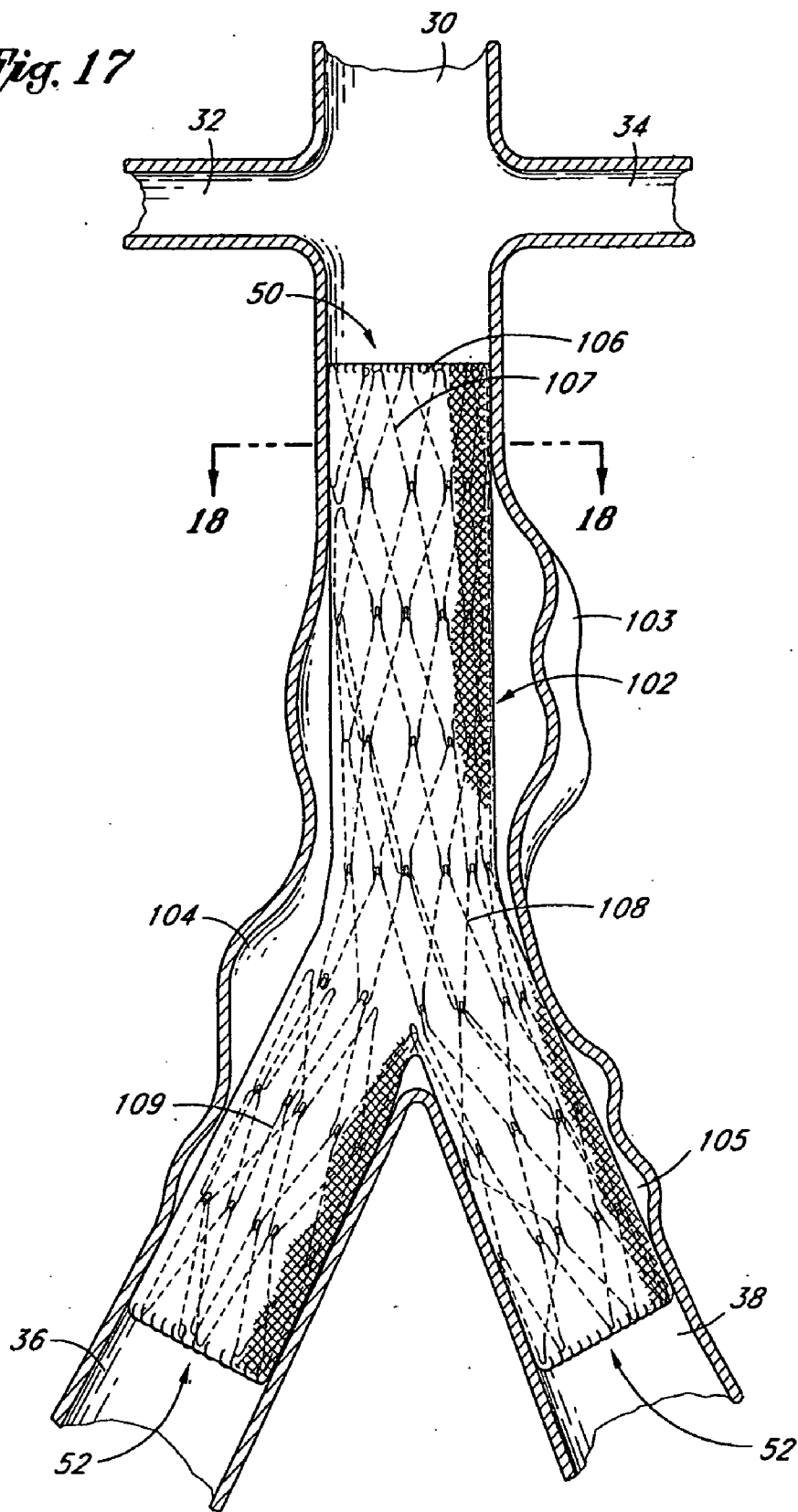
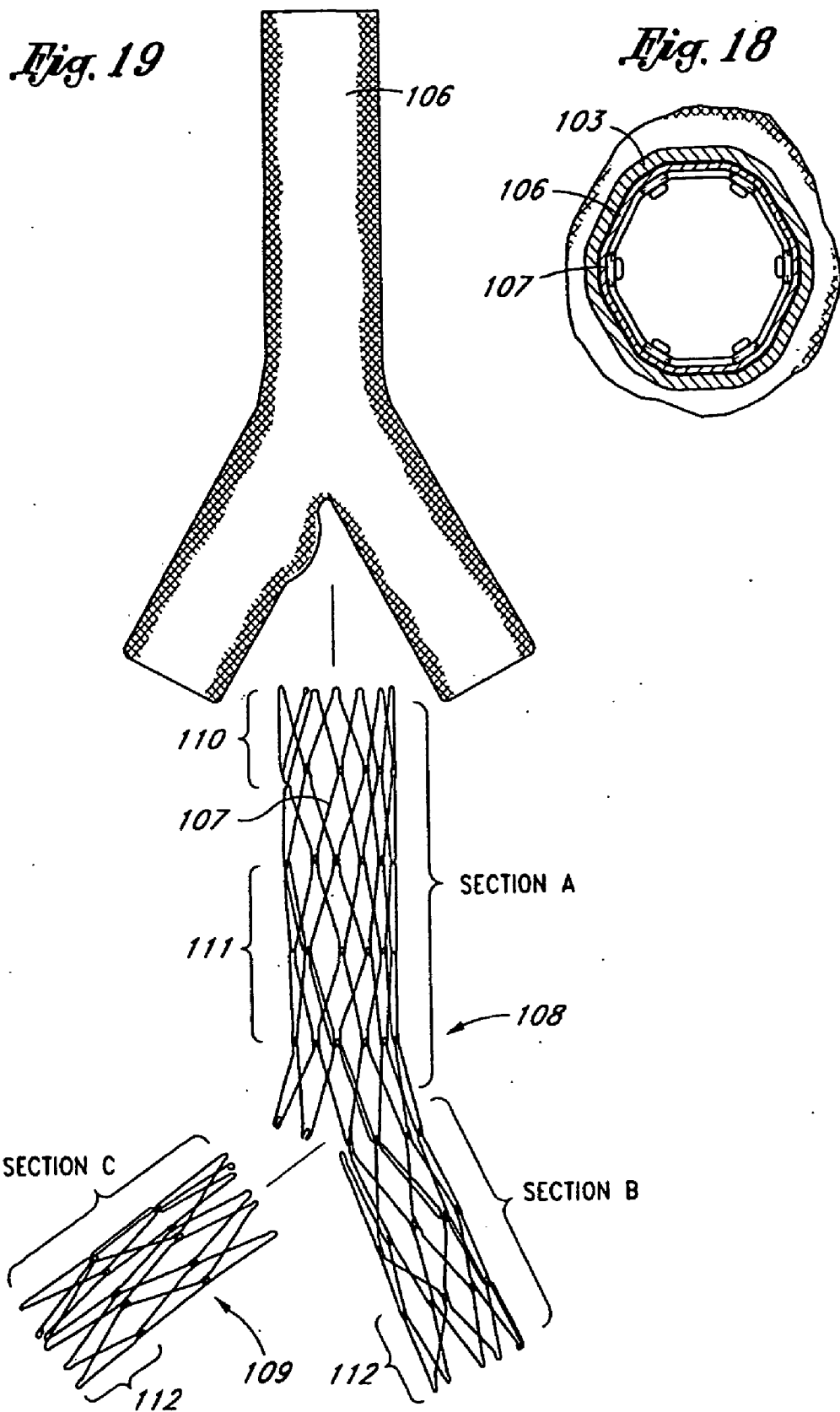

Fig. 17





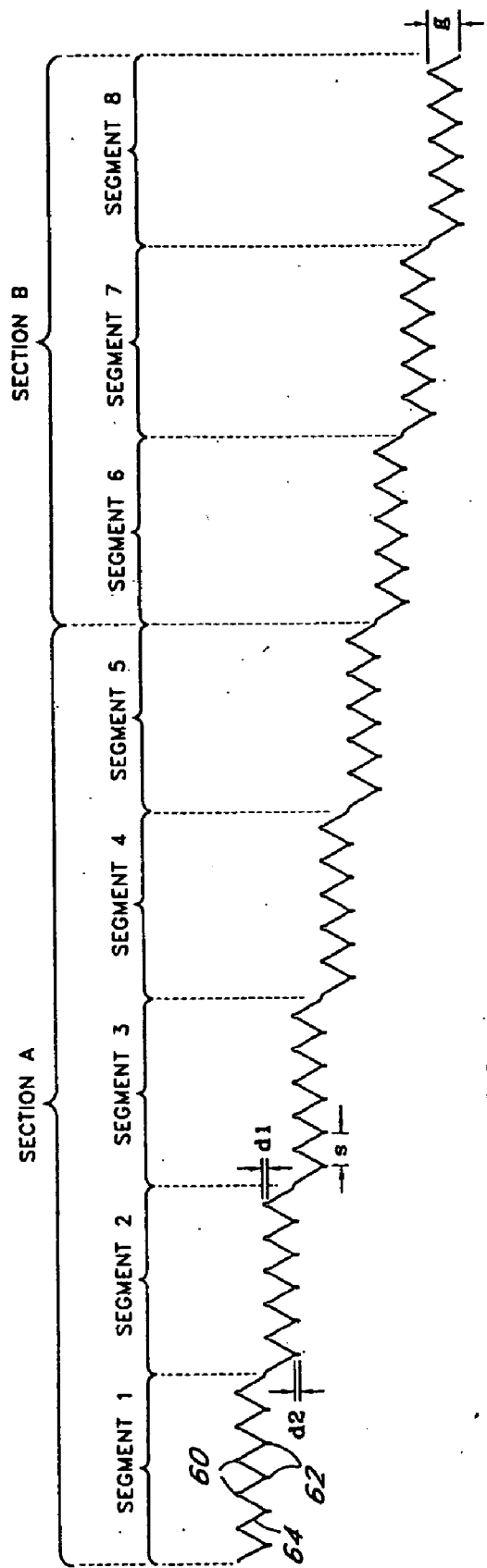

Fig. 20

Fig. 22

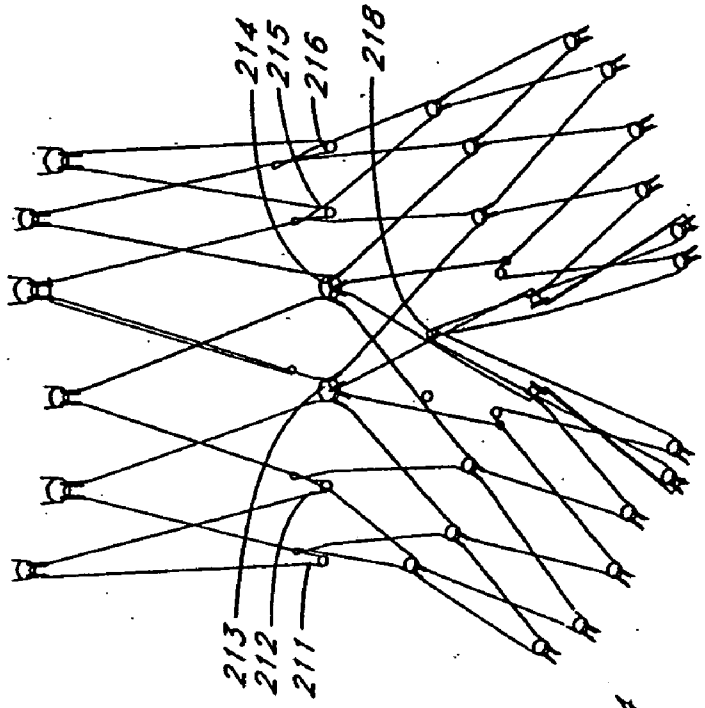
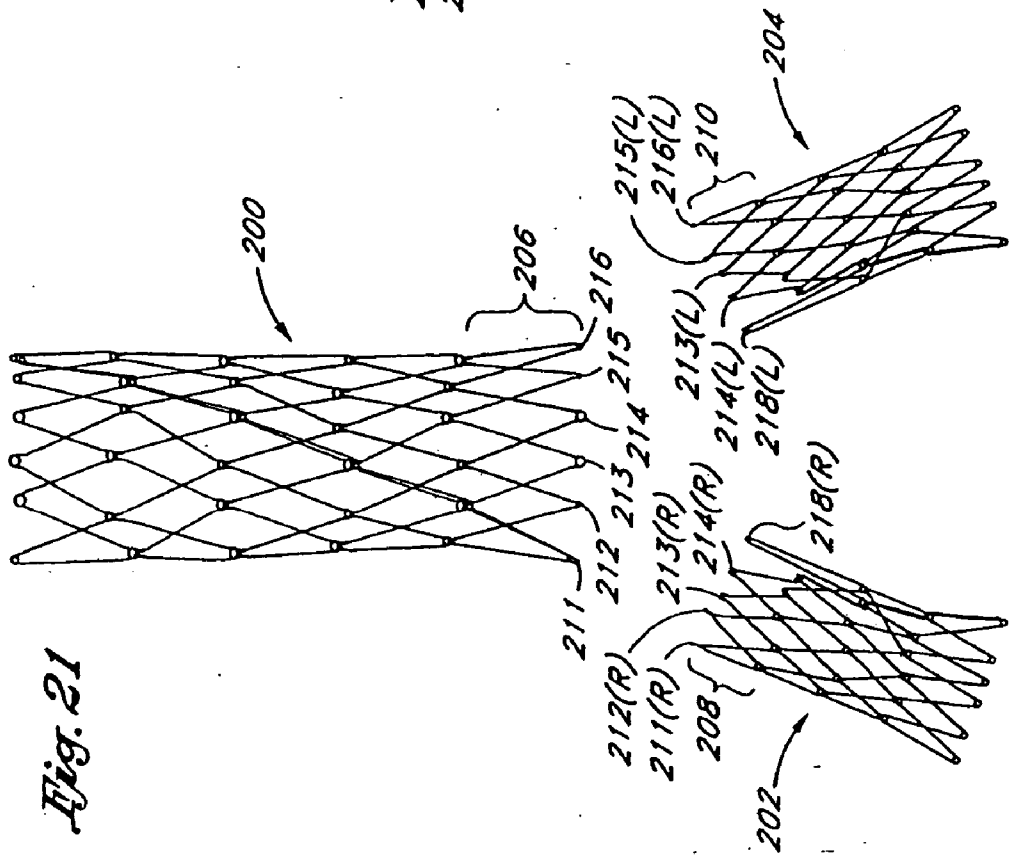

Fig. 21



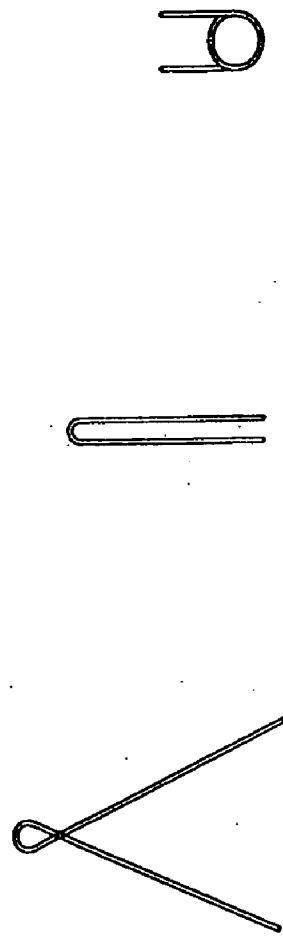
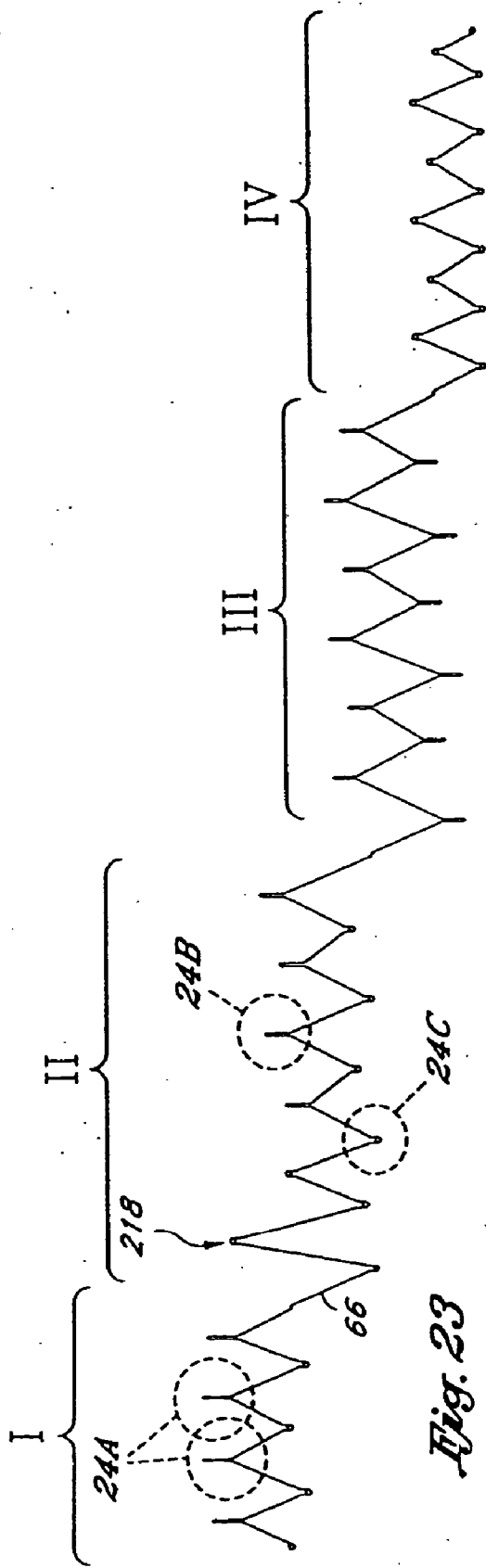

Fig. 25

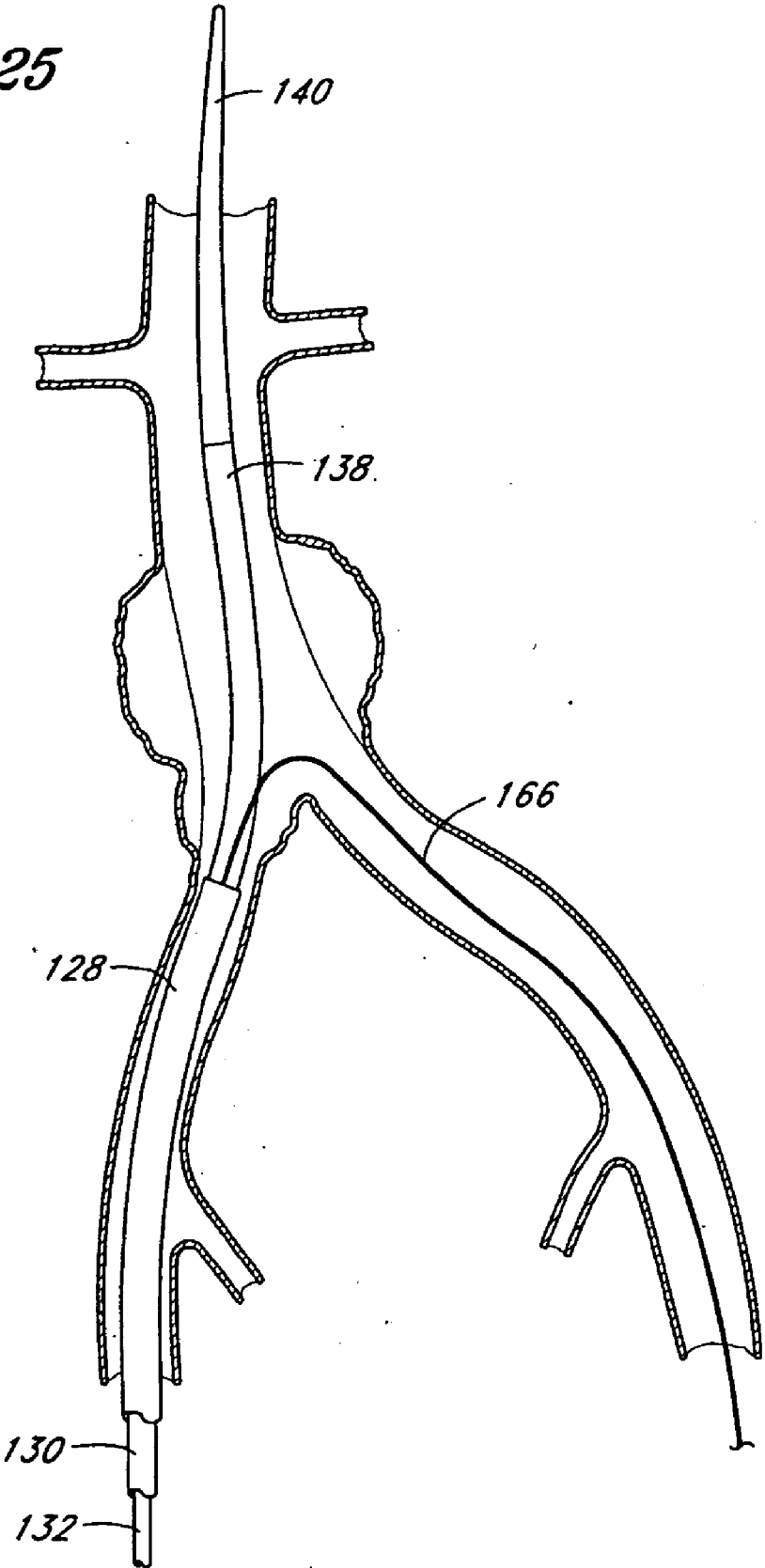

Fig. 26

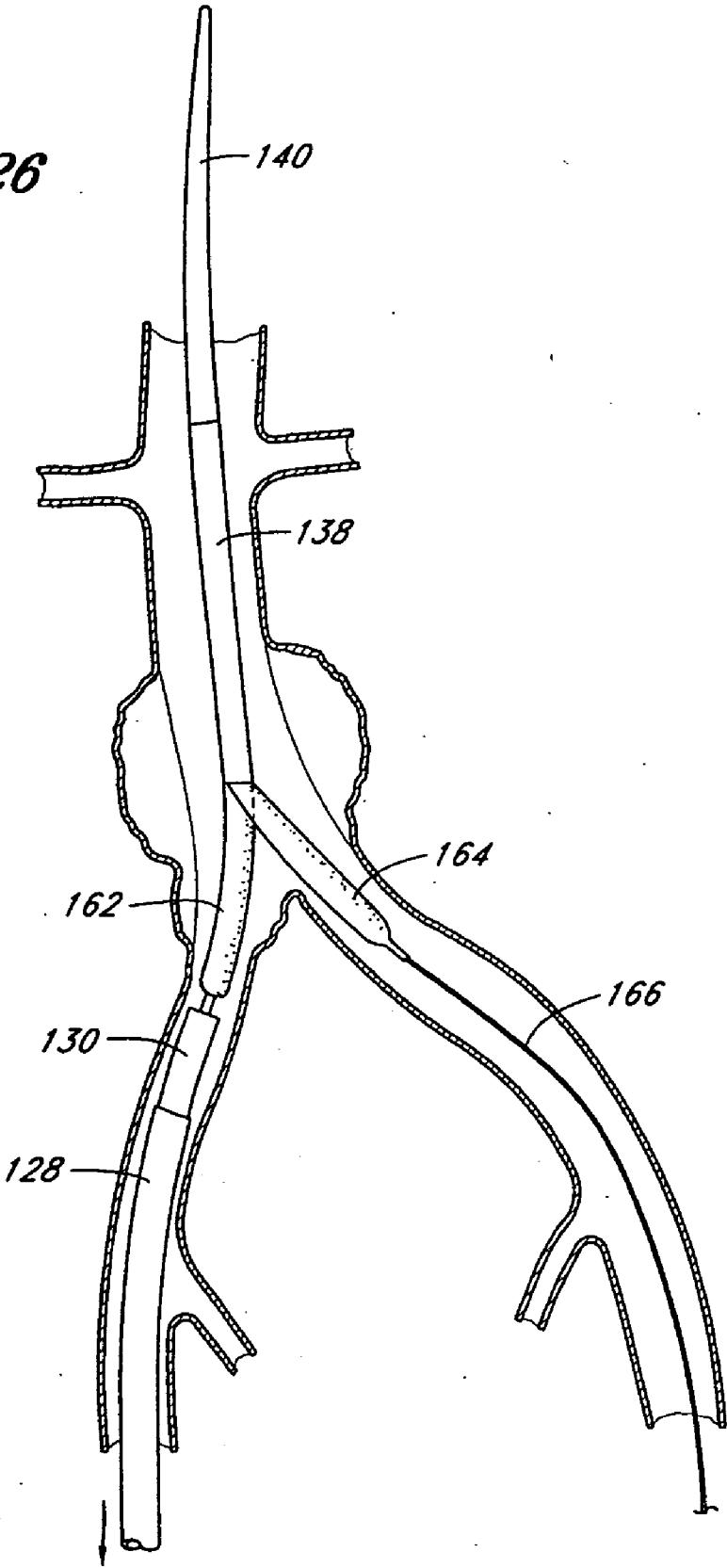

Fig. 27

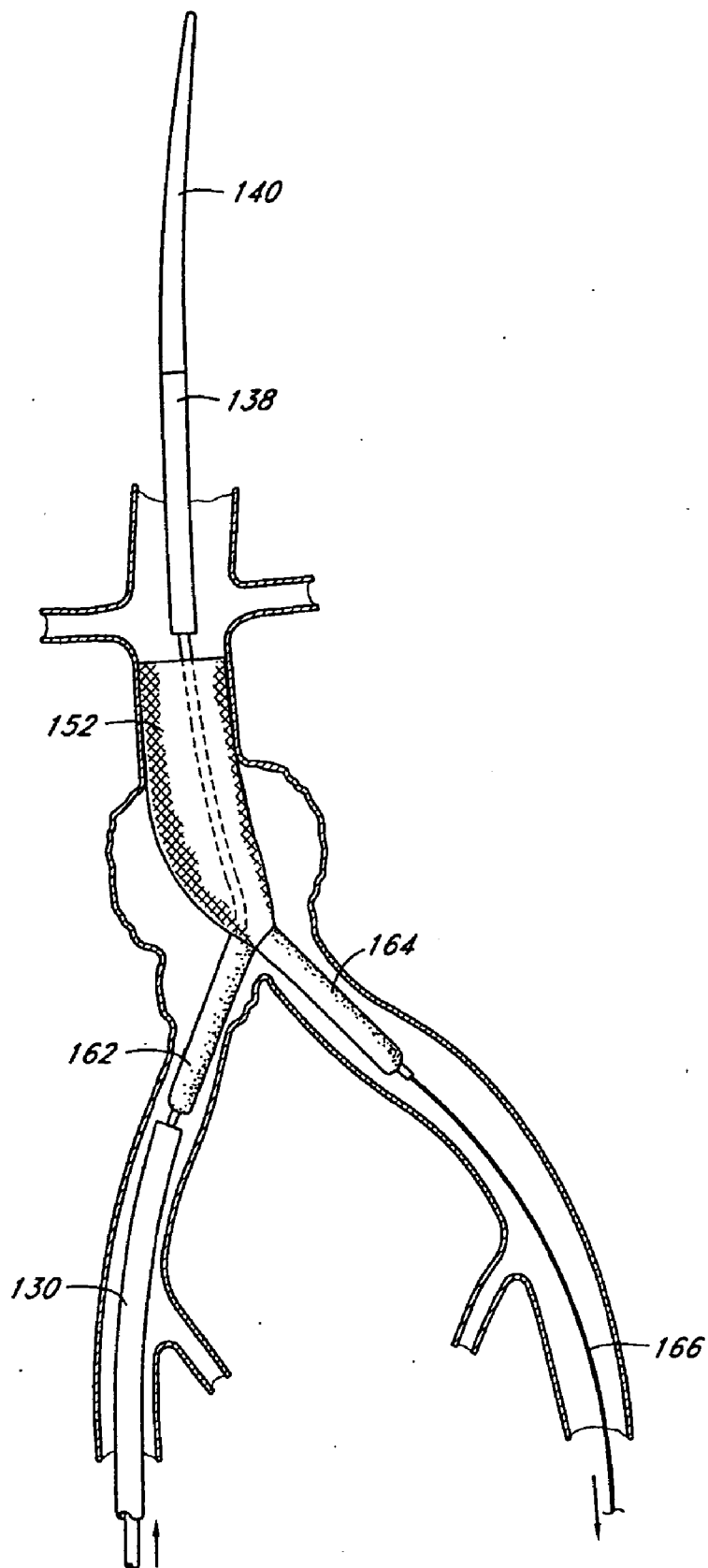

Fig. 28

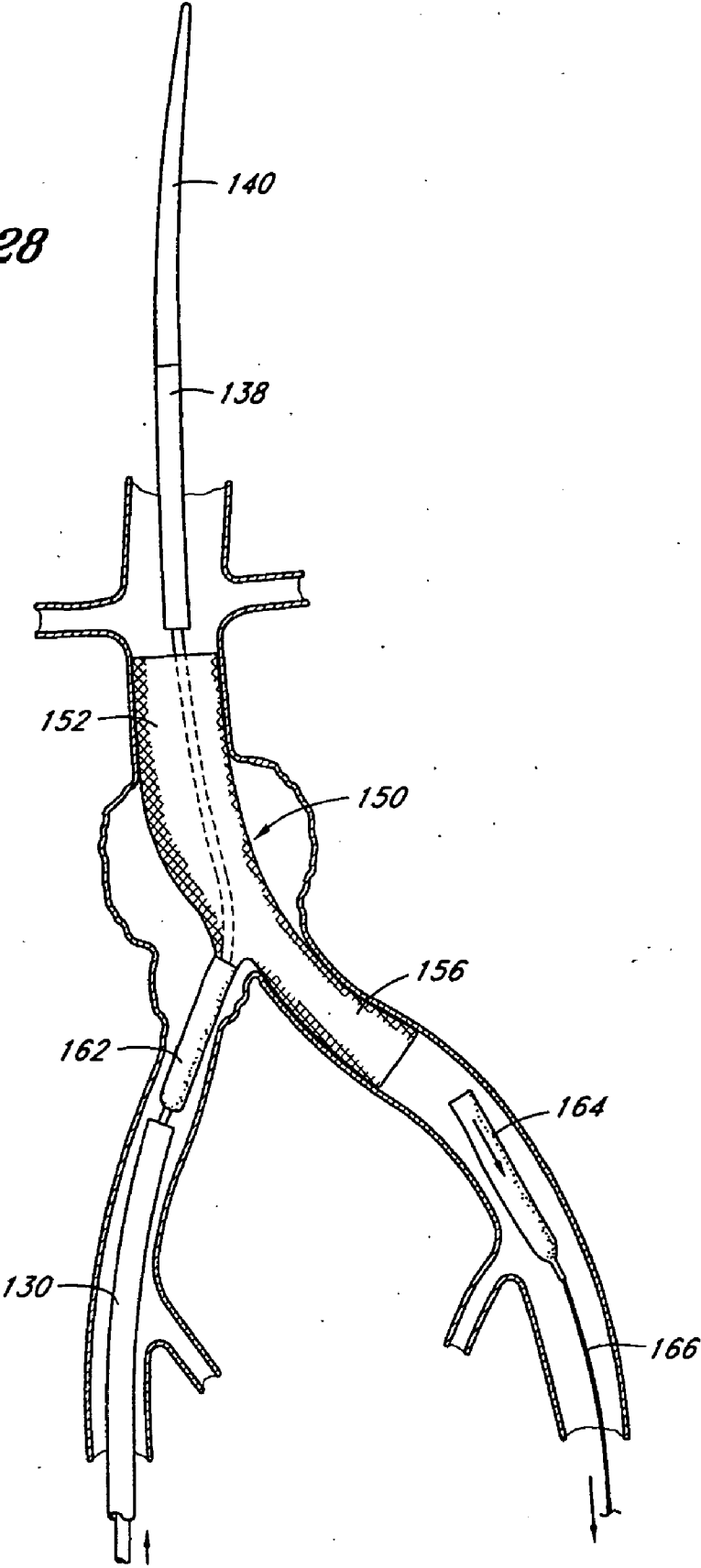

Fig. 29

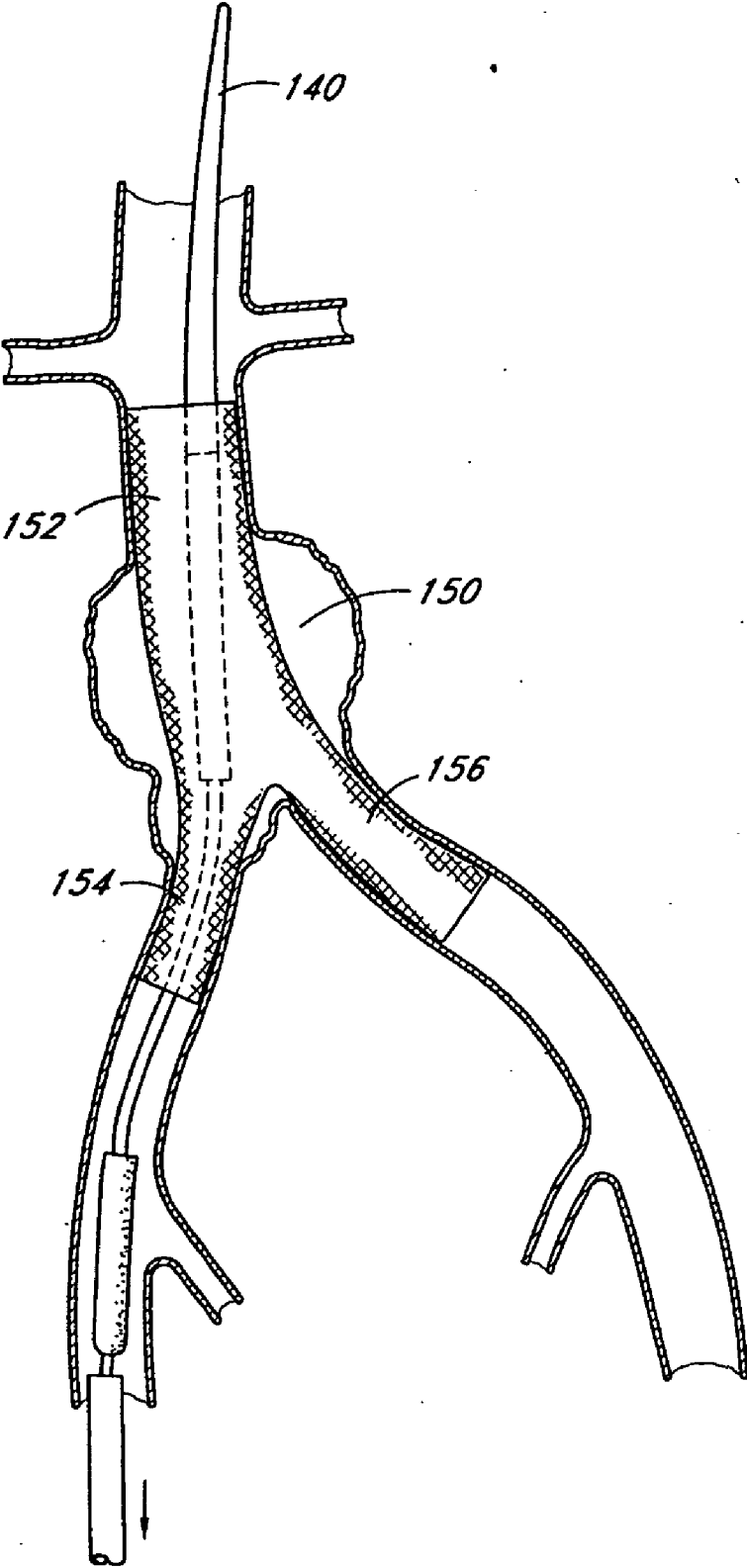

Fig. 30

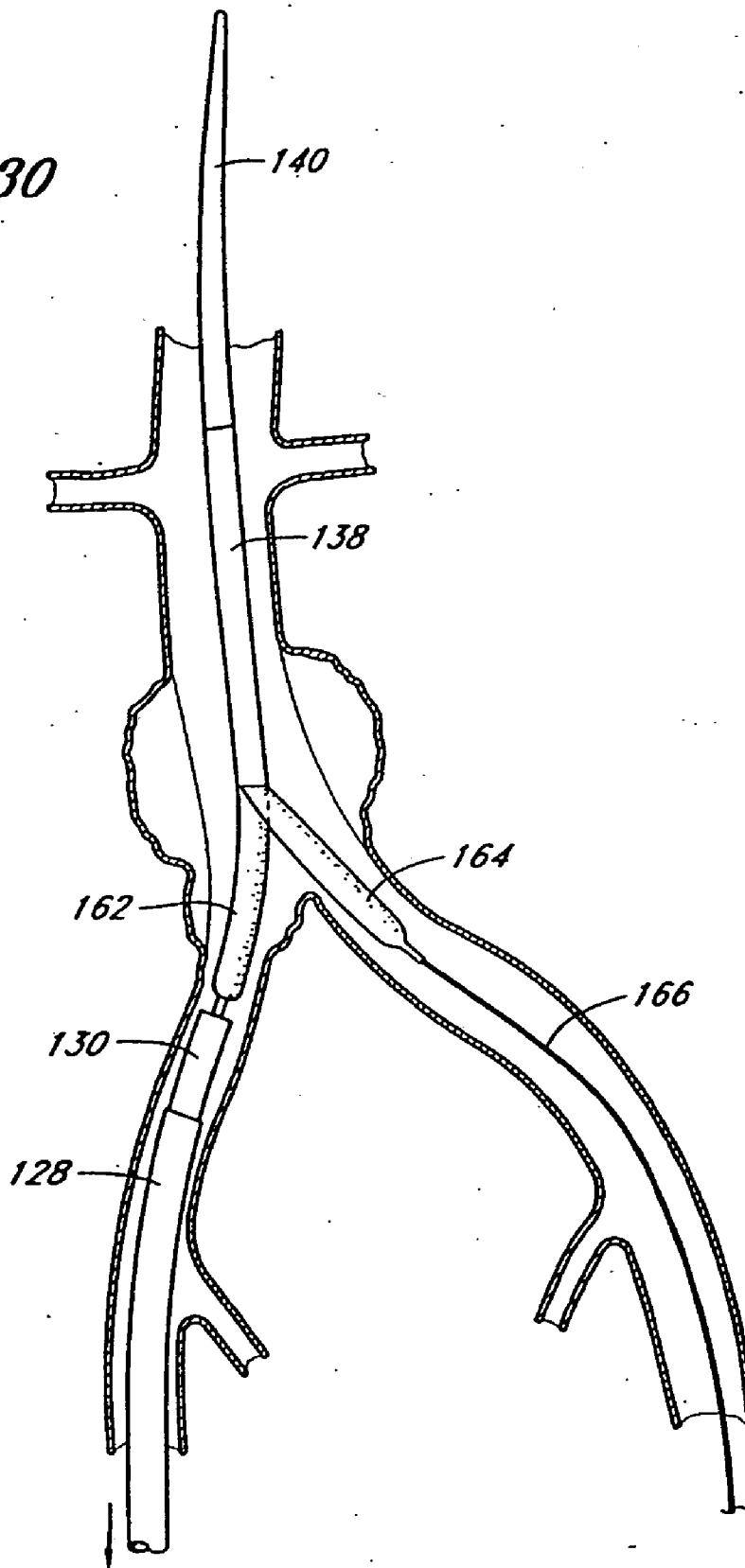

Fig. 31

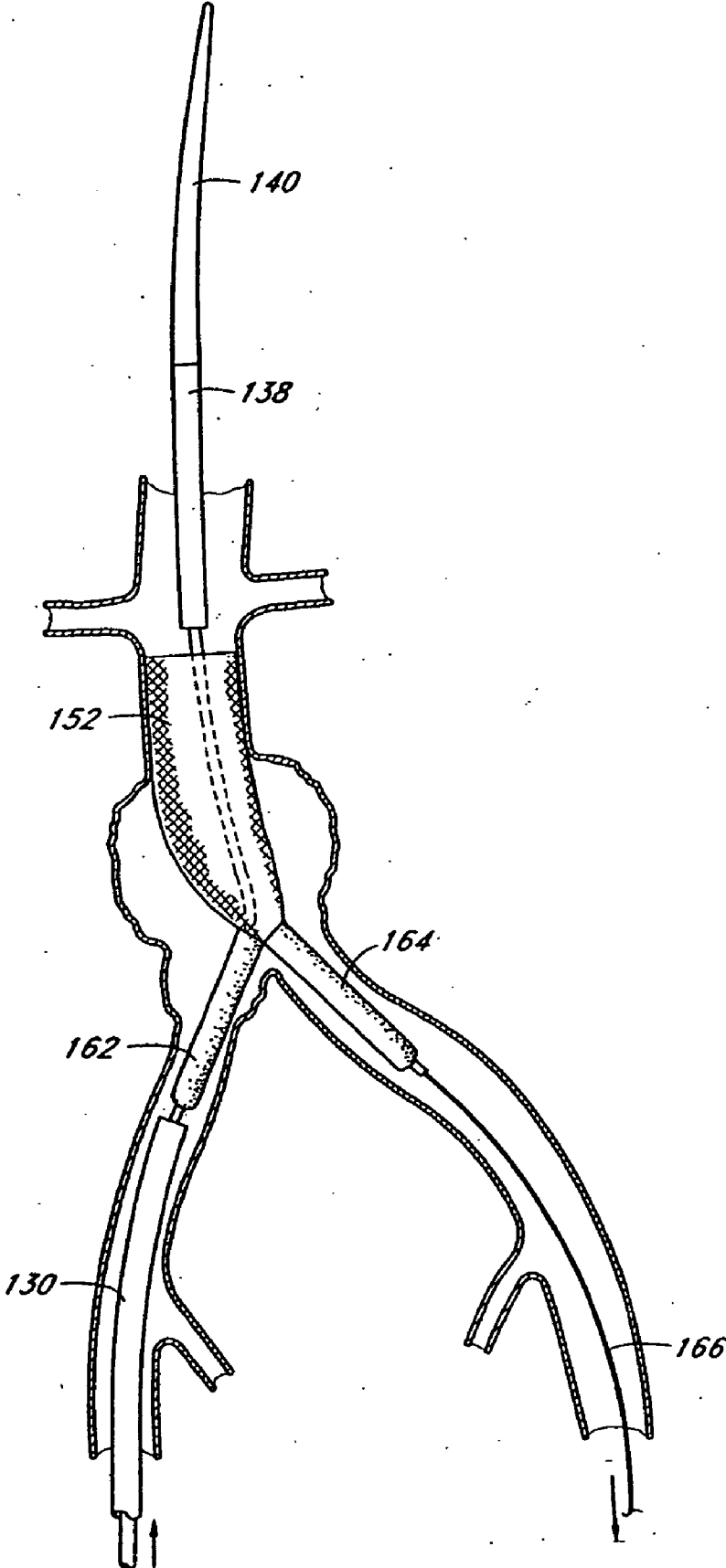

Fig. 32

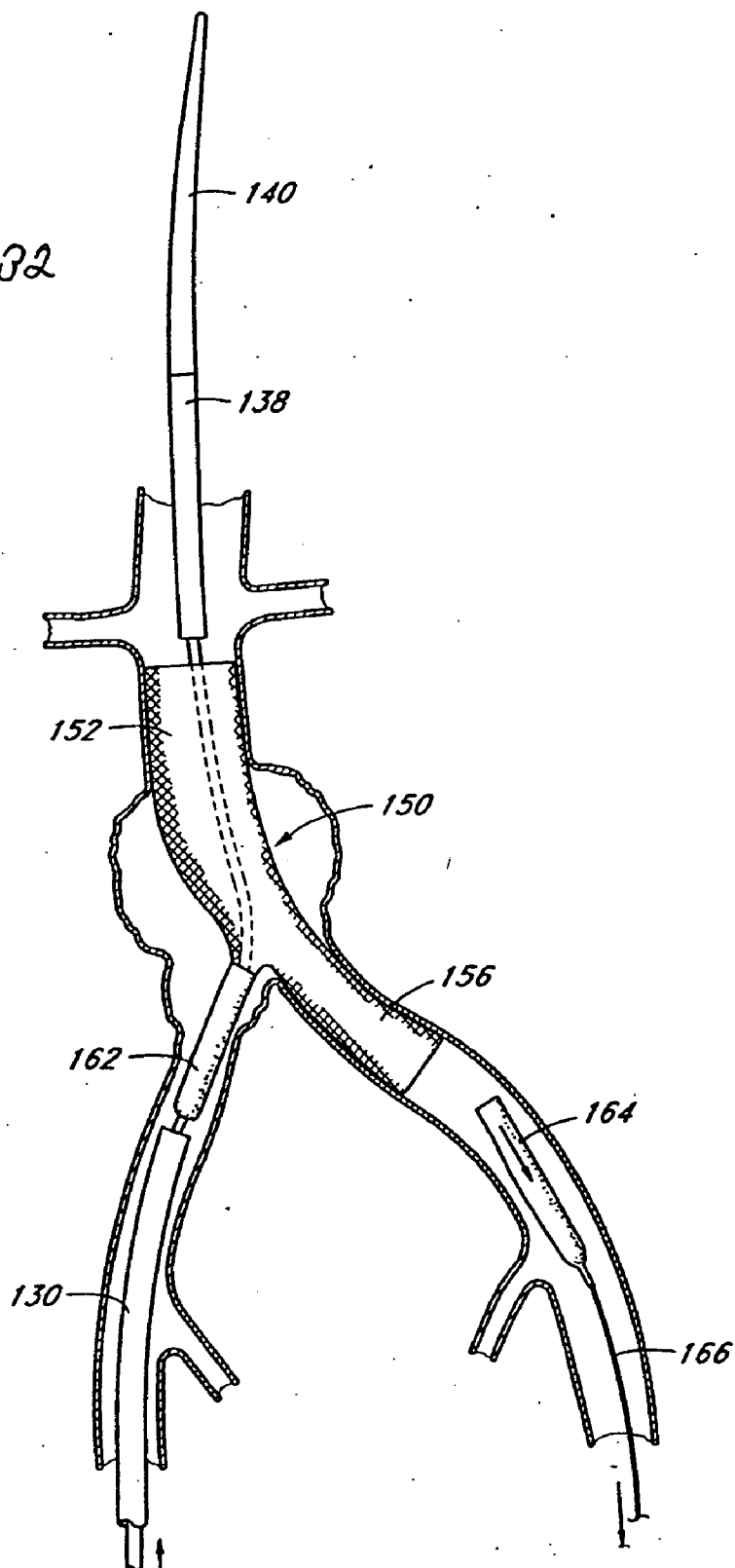
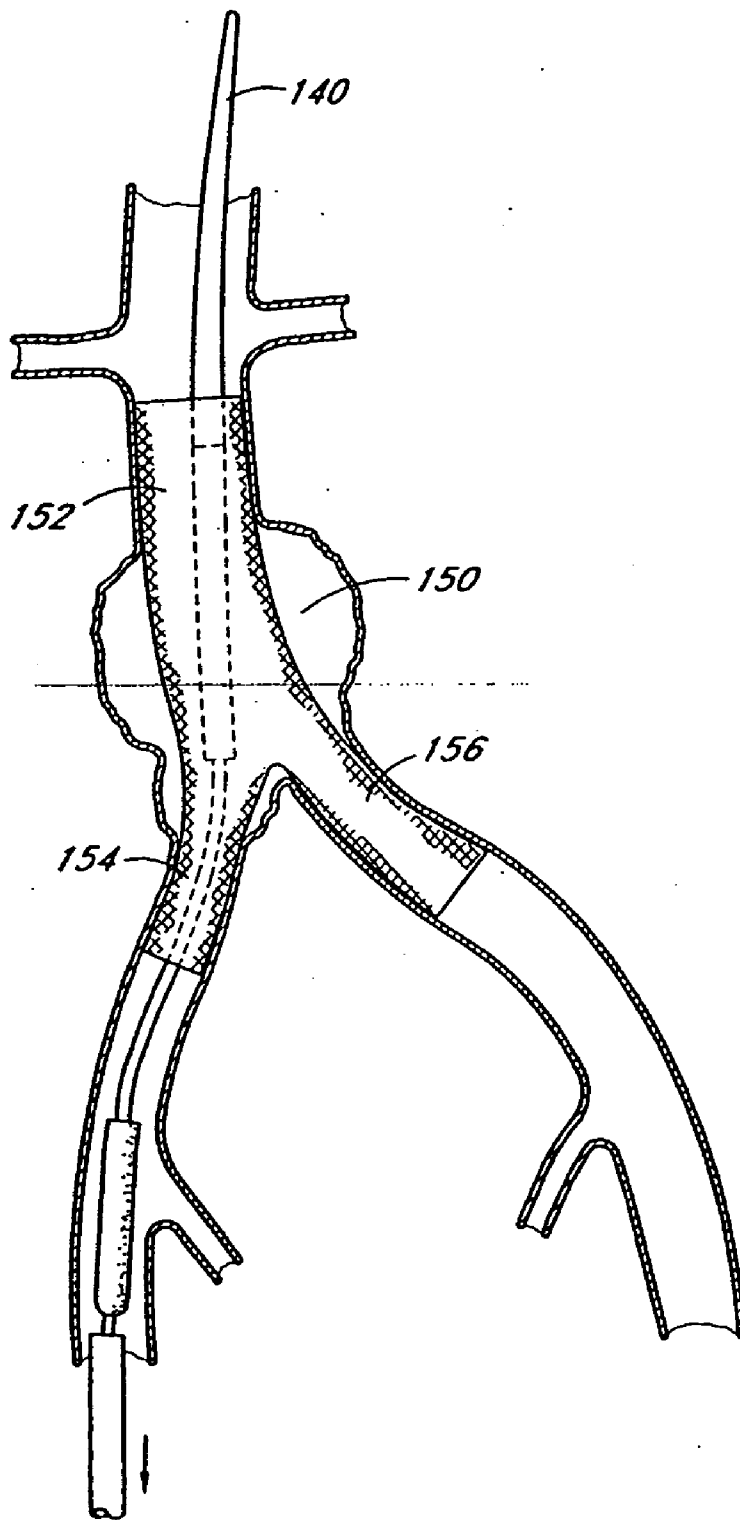

Fig. 33



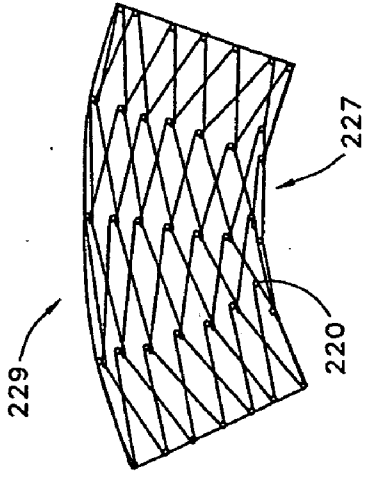

FIG. 34C

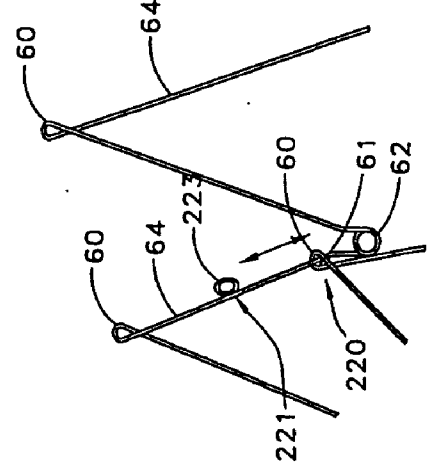

FIG. 34D

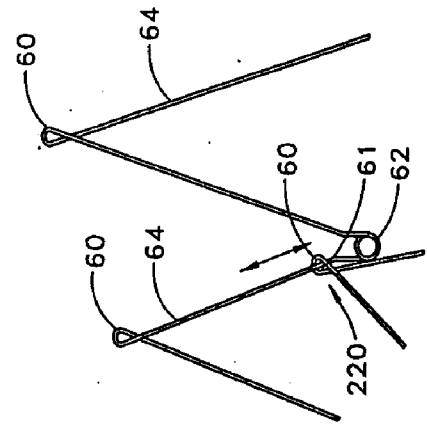

FIG. 34B

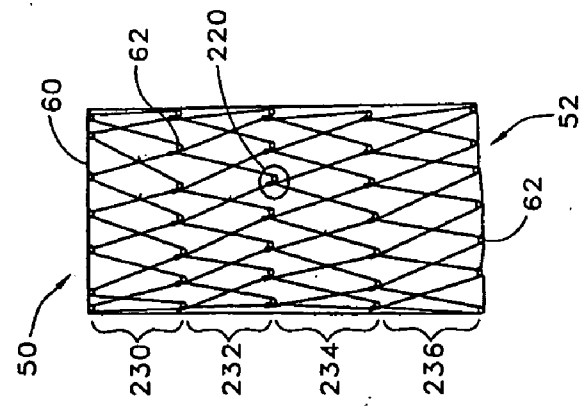

FIG. 34A

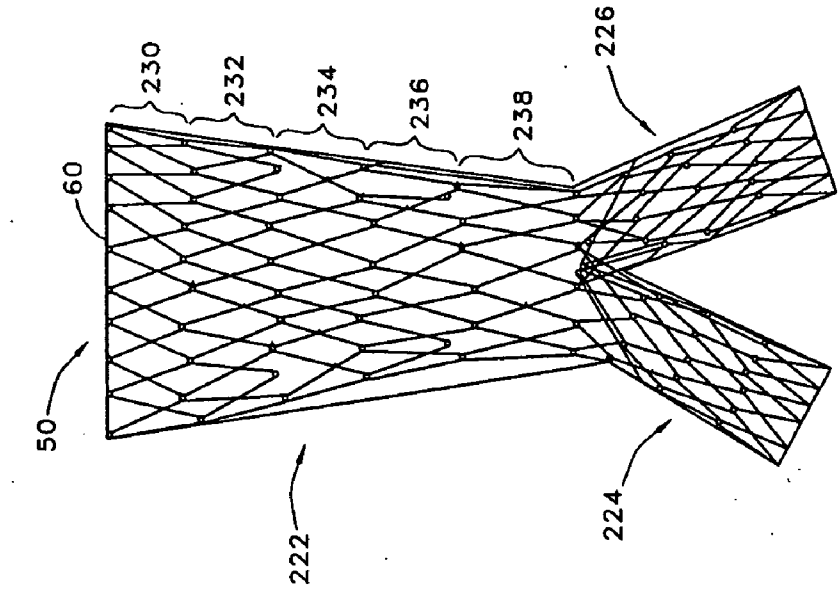

FIG. 35A

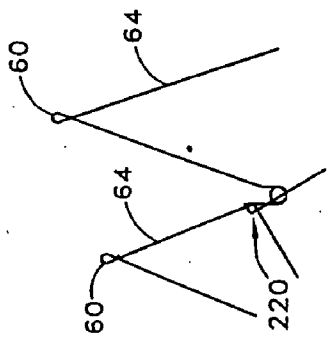

FIG. 35B

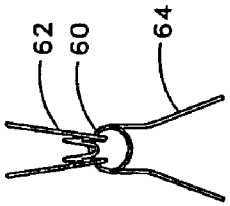

FIG. 35C

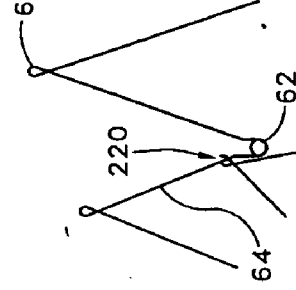

FIG. 35D

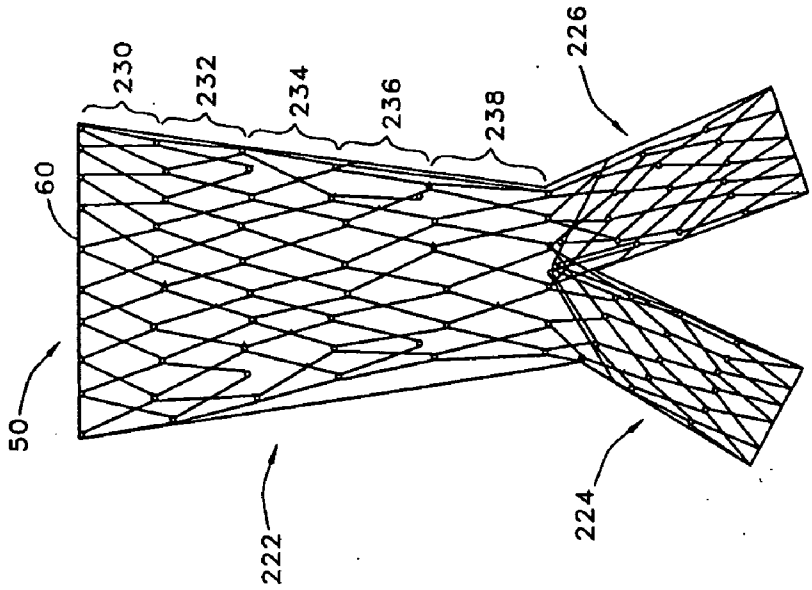

FIG. 36

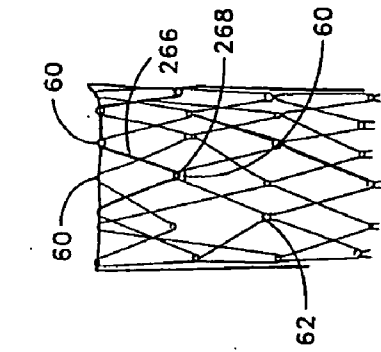

FIG. 39A

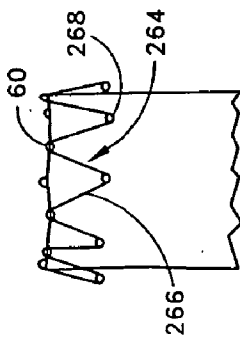

FIG. 39B



FIG. 388

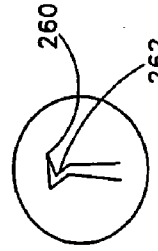

FIG. 38C

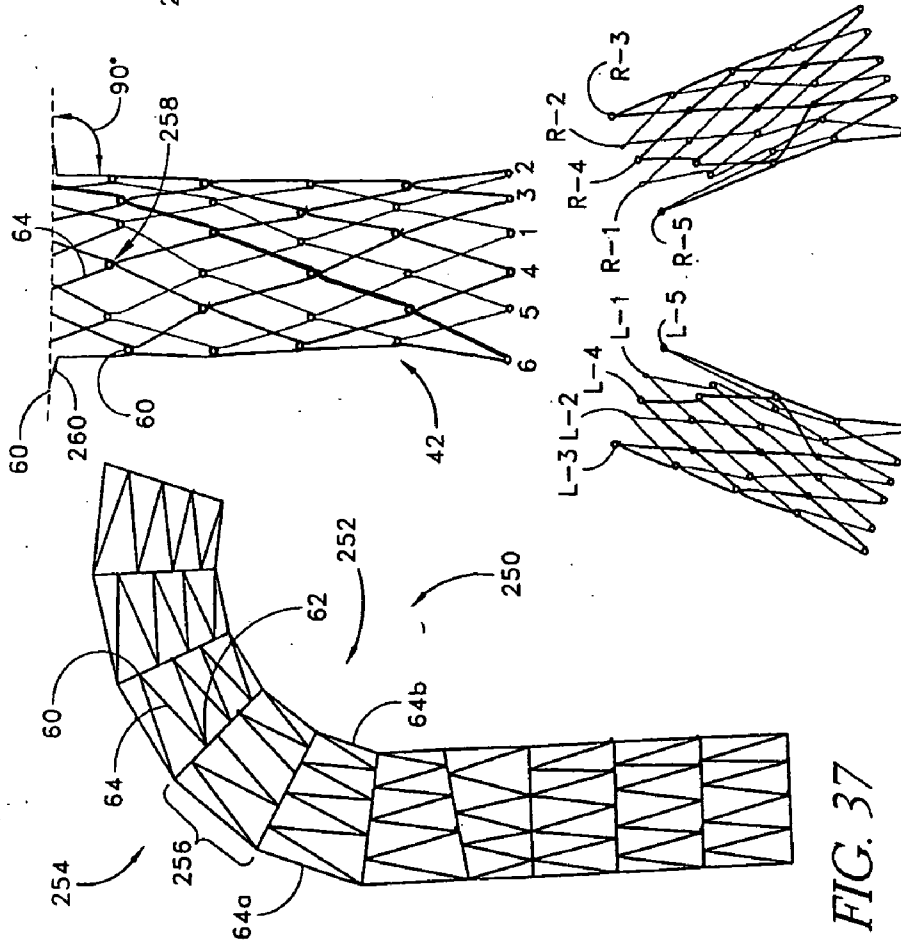

FIG. 37

FIG. 38A

IMPLANTABLE VASCULAR GRAFT

[0001] This is a continuation-in-part of U.S. patent application Ser. No. 09/728,582, filed Dec. 1, 2000, which is a continuation-in-part of U.S. patent application Ser. No. 09/251,363, filed Feb. 17, 1999, entitled "Articulated Bifurcation Graft", now U.S. Pat. No. 6,197,049 which is a continuation-in-part of U.S. patent application Ser. No. 09/210,280, filed Dec. 11, 1998, entitled "Endoluminal Vascular Prosthesis", now U.S. Pat. No. 6,187,036.

BACKGROUND OF THE INVENTION

[0002] The present invention relates to an endoluminal vascular prosthesis, and in particular, to a self-expanding bifurcated prosthesis for use in the treatment of abdominal aortic aneurysms.

[0003] An abdominal aortic aneurysm is a sac caused by an abnormal dilation of the wall of the aorta, a major artery of the body, as it passes through the abdomen. The abdomen is that portion of the body which lies between the thorax and the pelvis. It contains a cavity, known as the abdominal cavity, separated by the diaphragm from the thoracic cavity and lined with a serous membrane, the peritoneum. The aorta is the main trunk, or artery, from which the systemic arterial system proceeds. It arises from the left ventricle of the heart, passes upward, bends over and passes down through the thorax and through the abdomen to about the level of the fourth lumbar vertebra, where it divides into the two common iliac arteries.

[0004] The aneurysm usually arises in the infrarenal portion of the diseased aorta, for example, below the kidneys. When left untreated, the aneurysm may eventually cause rupture of the sac with ensuing fatal hemorrhaging in a very short time. High mortality associated with the rupture led initially to transabdominal surgical repair of abdominal aortic aneurysms. Surgery involving the abdominal wall, however, is a major undertaking with associated high risks. There is considerable mortality and morbidity associated with this magnitude of surgical intervention, which in essence involves replacing the diseased and aneurysmal segment of blood vessel with a prosthetic device which typically is a synthetic tube, or graft, usually fabricated of Polyester, Urethane, DACRON®, TEFLON®, or other suitable material.

[0005] To perform the surgical procedure requires exposure of the aorta through an abdominal incision which can extend from the rib cage to the pubis. The aorta must be closed both above and below the aneurysm, so that the aneurysm can then be opened and the thrombus, or blood clot, and arteriosclerotic debris removed. Small arterial branches from the back wall of the aorta are tied off. The DACRON® tube, or graft, of approximately the same size of the normal aorta is sutured in place, thereby replacing the aneurysm. Blood flow is then reestablished through the graft. It is necessary to move the intestines in order to get to the back wall of the abdomen prior to clamping off the aorta.

[0006] If the surgery is performed prior to rupturing of the abdominal aortic aneurysm, the survival rate of treated patients is markedly higher than if the surgery is performed after the aneurysm ruptures, although the mortality rate is still quite high. If the surgery is performed prior to the aneurysm rupturing, the mortality rate is typically slightly

less than 10%. Conventional surgery performed after the rupture of the aneurysm is significantly higher, one study reporting a mortality rate of 66.5%. Although abdominal aortic aneurysms can be detected from routine examinations, the patient does not experience any pain from the condition. Thus, if the patient is not receiving routine examinations, it is possible that the aneurysm will progress to the rupture stage, wherein the mortality rates are significantly higher.

[0007] Disadvantages associated with the conventional, prior art surgery, in addition to the high mortality rate include the extended recovery period associated with such surgery; difficulties in suturing the graft, or tube, to the aorta; the loss of the existing aorta wall and thrombosis to support and reinforce the graft; the unsuitability of the surgery for many patients having abdominal aortic aneurysms; and the problems associated with performing the surgery on an emergency basis after the aneurysm has ruptured. A patient can expect to spend from one to two weeks in the hospital after the surgery, a major portion of which is spent in the intensive care unit, and a convalescence period at home from two to three months, particularly if the patient has other illnesses such as heart, lung, liver, and/or kidney disease, in which case the hospital stay is also lengthened. The graft must be secured, or sutured, to the remaining portion of the aorta, which may be difficult to perform because of the thrombosis present on the remaining portion of the aorta. Moreover, the remaining portion of the aorta wall is frequently friable, or easily crumbled.

[0008] Since many patients having abdominal aortic aneurysms have other chronic illnesses, such as heart, lung liver, and/or kidney disease, coupled with the fact that many of these patients are older, the average age being approximately 67 years old, these patients are not ideal candidates for such major surgery.

[0009] More recently, a significantly less invasive clinical approach to aneurysm repair, known as endovascular grafting, has been developed. Parodi, et al. provide one of the first clinical descriptions of this therapy. Parodi, J. C., et al., "Transfemoral Intraluminal Graft Implantation for Abdominal Aortic Aneurysms," 5 *Annals of Vascular Surgery* 491 (1991). Endovascular grafting involves the transluminal placement of a prosthetic arterial graft within the lumen of the artery.

[0010] In general, transluminally implantable prostheses adapted for use in the abdominal aorta comprise a tubular wire cage surrounded by a tubular PTFE or Dacron sleeve. Both balloon expandable and self expandable support structures have been proposed. Endovascular grafts adapted to treat both straight segment and bifurcation aneurysms have also been proposed.

[0011] Notwithstanding the foregoing, there remains a need for a structurally simple, easily deployable transluminally implantable endovascular prosthesis, with a support structure adaptable to span either a straight or bifurcated aortic aneurysm. Preferably, the tubular prosthesis can be self expanded at the site to treat the abdominal aortic aneurysm, and exhibits flexibility to accommodate nonlinear anatomies and normal anatomical movement.

SUMMARY OF THE INVENTION

[0012] There is provided in accordance with one aspect of the present invention, an endoluminal prosthesis having an

endoskeleton for supporting tubular polymeric sleeve, and a partial exoskeleton for positioning at the anatomically proximal end, to minimize migration and risks of endoleaks. The prosthesis comprises at least one elongate flexible wire, formed into a plurality of axially adjacent tubular segments spaced along an axis. Each tubular segment comprises a zig-zag section of wire, having a plurality of proximal bends and distal bends. At least one of the plurality of proximal bends and plurality of distal bends have loops thereon. A tubular polymeric sleeve is carried by the prosthesis.

[0013] The prosthesis is radially compressible into a first, reduced cross sectional configuration for implantation into a body lumen, and self expandable to a second, enlarged cross sectional configuration at a treatment site in a body lumen. At least a first portion of wire in one tubular segment is positioned on a radially outwardly facing surface of the sleeve. A radially inwardly facing surface of the sleeve is in contact with a second portion of wire.

[0014] In one application, the prosthesis comprises at least six proximal bends on a distal segment, and at least three of the proximal bends reside on the outside of the tubular sleeve and the remainder of the proximal bends are positioned on the inside of the tubular sleeve. At least about 30%, and generally from about 40% to about 70% of the proximal bends on a distal segment reside on the outside of the tubular sleeve. In this context, distal refers to catheter distal which is the same as anatomically proximal. The proximal bends on the inside of the tubular sleeve are connected to distal bends on a proximally adjacent segment inside of the tubular sleeve.

[0015] In accordance with another aspect of the present invention, there is provided a tubular wire support for a bifurcated endoluminal prosthesis. The wire support comprises a main body support structure having a proximal end, a distal end and a central lumen extending along a longitudinal axis therethrough. A first branch support structure, having a proximal end, a distal end and a central lumen therethrough, is provided such that the distal end of the first branch structure is connected to the proximal end of the main body support structure. A second branch support structure, having a proximal end, a distal end and a central lumen extending therethrough is provided, such that the distal end of the second branch support structure is connected to the proximal end of the main body support structure. A plurality of radially outwardly extending barbs or treads are provided on the main body, integrally formed on the wire support. The main body support structure and first and second branch support structures are preferably self expandable from a radially collapsed state to a radially expanded state.

[0016] The wire in each support structure is formed into a plurality of segments, each segment comprising a series of proximal bends, a series of distal bends, and a series of struts connecting the proximal and distal bends. The barbs may be formed by bending at least one of the proximal or distal bends such that it inclines radially outwardly from the longitudinal axis of the corresponding support structure. Preferably, the anchors comprise a plurality of distal bends on the main body support structure, to provide anchoring at the anatomically proximal end of the implanted tubular wire support.

[0017] In accordance with further aspect of the present invention, there is provided a tubular wire support for

combination with a sheath to produce a flexible bifurcated endoluminal prosthesis. The wire support comprises a main body support structure having a proximal end, a distal end and a central lumen extending therethrough, the support structure comprising at least a first and second axially adjacent tubular segments. Each segment comprises a plurality of wall struts connected by proximal and distal bends.

[0018] A first branch support structure, having a proximal end, a distal end and a central lumen therethrough is connected to the main body support structure. A second branch support structure, having a proximal end, a distal end and a central lumen extending therethrough, is connected to the main body support structure. At least two sliding links are provided in between the first and second segments on the main body support structure and at least one lock is provided on a wall strut for limiting axial movement of a sliding link along that strut.

[0019] In one application, the lock comprises a loop formed into the strut, for limiting the effective length of travel of the sliding link along that strut. At least about 30%, and in some devices at least 50%, and in other devices 100% of the links in between the first and second segments are provided with a sliding link configuration. At least about 30%, and in some applications at least about 50% of the sliding links are provided with a lock on the corresponding strut.

[0020] In accordance with a further aspect of the present invention, there is provided a flexible self expandable graft. The graft comprises a tubular main body support structure, having a proximal end and a distal end. The tubular body comprises at least a first tubular segment attached to a second tubular segment. A tubular polymeric sleeve surrounds at least a portion of the graft. Each of the first and second tubular segments comprise a plurality of proximal bends and distal bends connected by struts, surrounding a longitudinal axis such that a first strut is on a first side of the axis and a second strut is on a second side of the axis opposing the first side. In at least one segment, the first strut is shorter than the second strut. In some applications, at least two or three or four or more adjacent segments are provided with a shorter strut or struts on a first side of the axis compared to the corresponding strut or struts on the second side of the axis, to facilitate curvature of the graft.

[0021] Further features and advantages of the present invention will become apparent to those of ordinary skill in the art in view of the disclosure herein, when considered together with the attached drawings and claims.

BRIEF DESCRIPTION OF THE DRAWINGS

[0022] FIG. 1 is a schematic representation of a straight segment vascular prosthesis in accordance with the present invention, positioned within a symmetric abdominal aortic aneurysm.

[0023] FIG. 2 is an exploded view of an endoluminal vascular prosthesis in accordance with the present invention, showing a self expandable wire support structure separated from an outer tubular sleeve.

[0024] FIG. 3 is a plan view of a formed wire useful for rolling about an axis into a multi-segment support structure in accordance with the present invention.

[0025] FIG. 4 is an enlarged detail view of a portion of the formed wire illustrated in FIG. 3.

[0026] FIG. 5 is a schematic view of a portion of a wire cage wall, illustrating folded link connections between adjacent apices.

[0027] FIG. 6 is an exploded view of two opposing apices dimensioned for one embodiment of the folded link connection of the present invention.

[0028] FIG. 7 is an enlarged view of a folded link, taken along the lines 7-7 in FIG. 5.

[0029] FIG. 8 is a cross-sectional view taken along the line 8-8 in FIG. 7.

[0030] FIGS. 6A, 7A, 8A, 7B, 8B, 7C, and 7D illustrate alternate embodiments of a folded link constructed from an opposing apex pair.

[0031] FIG. 9 is a partial view of a junction between two adjacent tubular segments, illustrating oppositely oriented folded links in accordance with the present invention.

[0032] FIG. 10 is a cross-section taken along the line 10-10 in FIG. 9.

[0033] FIG. 11 is a schematic view of a portion of a wall of a graft, laid out flat, illustrating an alternating folded link pattern.

[0034] FIG. 12 is a wall pattern as in FIG. 11, illustrating a multi-zone folded link pattern.

[0035] FIGS. 12A through 12C illustrate an alternate wall pattern, which permits axially staggered links between adjacent graft segments.

[0036] FIG. 13 is a schematic illustration of a straight segment delivery catheter in accordance with the present invention, positioned within an abdominal aortic aneurysm.

[0037] FIG. 14 is an illustration as in FIG. 13, with the straight segment endoluminal prosthesis partially deployed from the delivery catheter.

[0038] FIG. 15 is a schematic representation of the abdominal aortic anatomy, with an endoluminal vascular prostheses of the present invention positioned within each of the right renal artery and the right common iliac.

[0039] FIG. 16 is a schematic representation of a straight segment graft in accordance with a further embodiment of the present invention, with side openings to permit renal perfusion.

[0040] FIG. 17 is a schematic representation of a bifurcated vascular prosthesis in accordance with the present invention, positioned at the bifurcation between the abdominal aorta and the right and left common iliac arteries.

[0041] FIG. 18 is a cross-sectional view of the implanted graft taken along the lines 18-18 of FIG. 17.

[0042] FIG. 19 is an exploded view of the bifurcated vascular prosthesis in accordance with the present invention, showing a two-part self expandable wire support structure separated from an outer tubular sleeve.

[0043] FIG. 20 is a plan view of formed wire useful for rolling about an axis into an aortic trunk segment and a first iliac branch segment support structure in accordance with the present invention.

[0044] FIG. 21 is a schematic representation of another embodiment of the wire support structure for the bifurcated vascular prosthesis of the present invention, showing a main body support structure and separate branch support structures.

[0045] FIG. 22 is a schematic representation of the three-part wire support structure as in FIG. 21, illustrating the sliding articulation between the branch supports and the main body support.

[0046] FIG. 23 is a plan view of formed wire useful for rolling about an axis to form a branch support structure in accordance with the three-part support embodiment of the present invention shown in FIG. 21.

[0047] FIGS. 24A, 24B and 24 C are enlargements of the apices delineated by lines A, B and C, respectively, in FIG. 23.

[0048] FIG. 25 is side elevational cross-section of a bifurcation graft delivery catheter in accordance with the present invention.

[0049] FIG. 26 is an enlargement of the portion delineated by the line 26-26 in FIG. 25.

[0050] FIG. 27 is a cross-section taken along the line 27-27 in FIG. 26.

[0051] FIG. 28 is a cross-section taken along the line 28-28 in FIG. 26.

[0052] FIG. 29 is a schematic representation of a bifurcated graft deployment catheter of the present invention, positioned within the ipsilateral iliac and the aorta, with the contralateral guidewire positioned within the contralateral iliac.

[0053] FIG. 30 is a schematic representation as in FIG. 29, with the outer sheath proximally retracted and the compressed iliac branches of the graft moving into position within the iliac arteries.

[0054] FIG. 31 is a schematic representation as in FIG. 30, with the compressed iliac branches of the graft within the iliac arteries, and the main aortic trunk of the graft deployed within the aorta.

[0055] FIG. 32 is a schematic representation as in FIG. 31, with the contralateral iliac branch of the graft deployed.

[0056] FIG. 33 is a schematic representation as in FIG. 32, following deployment of the ipsilateral branch of the graft.

[0057] FIG. 34a is a side elevational view of a flexible straight graft in accordance with the present invention.

[0058] FIG. 34b is a detail view of a sliding link in the embodiment of FIG. 34a.

[0059] FIG. 34c is a side elevational view of the graft of FIG. 34a, having a radius of curvature.

[0060] FIG. 34d is a detail view as in FIG. 34b, illustrating a lock for limiting axial compression of the sliding link.

[0061] FIG. 35a is a side elevational view of a bifurcated graft which includes sliding links in accordance with the present invention.

[0062] FIG. 35*b* is a detail view of a sliding link in a proximal portion of the graft of FIG. 35*a*.

[0063] FIG. 35*c* is a detail view of a folded link utilized in an intermediate zone of the graft of FIG. 35*a*.

[0064] FIG. 35*d* is a detail view of a sliding link utilized in the iliac branches of the graft of FIG. 35*a*.

[0065] FIG. 36 is a side elevational view of a tapered bifurcated graft in accordance with the present invention.

[0066] FIG. 37 is a schematic side elevational view of a graft having short graft sections on one side to facilitate a curve.

[0067] FIG. 38*a* illustrates a bifurcation or straight segment graft having a plurality of proximal barbs.

[0068] FIG. 38*b* is a detailed view of a barb of the type illustrated in FIG. 38*a*.

[0069] FIG. 38*c* is an alternate barb configuration.

[0070] FIG. 39*a* is a fractional side elevational view of a graft assembly having a partial exoskeleton.

[0071] FIG. 39*b* is a partial side elevational view of an alternate exoskeleton configuration.

[0072] FIG. 39*c* is a partial side elevational view of a second alternate partial exoskeleton configuration.

DETAILED DESCRIPTION OF THE PREFERRED EMBODIMENT

[0073] Referring to FIG. 1, there is disclosed a schematic representation of the abdominal part of the aorta and its principal branches. In particular, the abdominal aorta 30 is characterized by a right renal artery 32 and left renal artery 34. The large terminal branches of the aorta are the right and left common iliac arteries 36 and 38. Additional vessels (e.g., second lumbar, testicular, inferior mesenteric, middle sacral) have been omitted for simplification. A generally symmetrical aneurysm 40 is illustrated in the infrarenal portion of the diseased aorta. An expanded straight segment endoluminal vascular prosthesis 42, in accordance with the present invention, is illustrated spanning the aneurysm 40.

[0074] The endoluminal vascular prosthesis 42 includes a polymeric sleeve 44 and a tubular wire support 46, which are illustrated in situ in FIG. 1. The sleeve 44 and wire support 46 are more readily visualized in the exploded view shown in FIG. 2. The endoluminal prosthesis 42 illustrated and described herein depicts an embodiment in which the polymeric sleeve 44 is situated concentrically outside of the tubular wire support 46. However, other embodiments may include a sleeve situated instead concentrically inside the wire support or on both of the inside and the outside of the wire support. Alternatively, the wire support may be embedded within a polymeric matrix which makes up the sleeve. Regardless of whether the sleeve 44 is inside or outside the wire support 46, the sleeve may be attached to the wire support by any of a variety of means, including laser bonding, adhesives, clips, sutures, dipping or spraying or others, depending upon the composition of the sleeve 44 and overall graft design.

[0075] The polymeric sleeve 44 may be formed from any of a variety of synthetic polymeric materials, or combinations thereof, including PTFE, PE, PET, Urethane, Dacron,

nylon, polyester or woven textiles. Preferably, the sleeve material exhibits relatively low inherent elasticity, or low elasticity out to the intended enlarged diameter of the wire cage 46. The sleeve material preferably has a thin profile, such as no larger than about 0.002 inches to about 0.005 inches.

[0076] In a preferred embodiment of the invention, the material of sleeve 44 is sufficiently porous to permit ingrowth of endothelial cells, thereby providing more secure anchorage of the prosthesis and potentially reducing flow resistance, shear forces, and leakage of blood around the prosthesis. Porosity in polymeric sleeve materials may be estimated by measuring water permeability as a function of hydrostatic pressure, which will preferably range from about 3 to 6 psi.

[0077] The porosity characteristics of the polymeric sleeve 44 may be either homogeneous throughout the axial length of the prosthesis 42, or may vary according to the axial position along the prosthesis 42. For example, referring to FIGS. 1 and 2, different physical properties will be called upon at different axial positions along the prosthesis 42 in use. At least a proximal portion 55 and a distal portion 59 of the prosthesis 42 will seat against the native vessel wall, proximally and distally of the aneurysm. In these proximal and distal portions, the prosthesis preferably encourages endothelial growth, or, at least, permits endothelial growth to infiltrate portions of the prosthesis in order to enhance anchoring and minimize leakage. A central portion 57 of the prosthesis spans the aneurysm, and anchoring is less of an issue. Instead, maximizing lumen diameter and minimizing blood flow through the prosthesis wall become primary objectives. Thus, in a central zone 57 of the prosthesis 42, the polymeric sleeve 44 may either be nonporous, or provided with pores of relatively lower porosity.

[0078] A multi-zoned prosthesis 42 may also be provided in accordance with the present invention by positioning a tubular sleeve 44 on a central portion 57 of the prosthesis, such that it spans the aneurysm to be treated, but leaving a proximal attachment zone 55 and a distal attachment zone 59 of the prosthesis 42 having exposed wires from the wire support 46. In this embodiment, the exposed wires 46 are positioned in contact with the vessel wall both proximally and distally of the aneurysm, such that the wire, over time, may become embedded in cell growth on the interior surface of the vessel wall.

[0079] In one embodiment of the prosthesis 42, the sleeve 44 and/or the wire support 46 is tapered, having a relatively larger expanded diameter at the proximal end 50 compared to the distal end 52. See, e.g., FIG. 36, discussed below. The tapered design may allow the prosthesis to conform better to the natural decreasing distal cross-section of the vessel, to reduce the risk of graft migration and potentially create better flow dynamics. The cage 46 can be provided with a proximal zone 55 and distal zone 59 that have a larger average expanded diameter than the central zone 57, as illustrated in FIG. 2. This configuration may desirably resist migration of the prosthesis within the vessel and reduce leakage around the ends of the prosthesis.

[0080] The tubular wire support 46 may be formed from a continuous single length of round or flattened wire. Alternatively, two or more wire lengths can be secured together to produce the wire support 46. The wire support 46 is

preferably formed in a plurality of discrete tubular segments **54**, connected together and oriented about a common axis. Each pair of adjacent segments **54** is connected by a connector **66** as illustrated in **FIG. 3**. The connectors **66** collectively produce a generally axially extending backbone which adds axial strength to the prosthesis **42**. Adjacent segments can be connected both by the backbone, as well as the interlocking junction disclosed below. Additional structures, including circumferentially extending sutures, solder joints, and wire loops may also be used.

[0081] The segmented configuration of the tubular wire support **46** facilitates a great deal of flexibility. Each segment **54**, though joined to adjacent segments, may be independently engineered to yield desired parameters. Each segment may range in axial length from about 0.3 to about 5 cm, and may be a uniform or non-uniform length around its circumference, such as to facilitate curvature as is discussed below. Generally, the shorter their length the greater the radial strength. An endoluminal prosthesis may include from about 1 to about 50 segments, preferably from about 3 to about 10 segments. For example, while a short graft patch, in accordance with the invention, may comprise only 2 segments and span a total of 2 to 3 cm, a complete graft may comprise 4 or more segments and span the entire aortic aneurysm. In addition to the flexibility and other functional benefits available through employment of different length segments, further flexibility can be achieved through adjustments in the number, angle, or configuration of the wire bends associated with the tubular support. See, e.g., **FIGS. 34 and 35**, discussed below.

[0082] In addition to having differing expanded diameters in different zones of the prosthesis **42**, different zones can be provided with a different radial expansion force, such as ranging from about 0.2 lbs. to about 0.8 lbs. In one embodiment, the proximal zone **55** is provided with a greater radial force than the central zone **57** and/or distal zone **59**. The greater radial force can be provided in any of a variety of manners discussed elsewhere herein, such as through the use of an additional one or two or three or more proximal bends **60**, distal bends **62** and wall sections **64** compared to a reference segment **54** in the central zone **57** or distal zone **59**. Alternatively, additional spring force can be achieved in the proximal zone **55** through the use of the same number of proximal bends **60** as in the rest of the prosthesis, but with a heavier gauge wire.

[0083] The wire may be made from any of a variety of different alloys, such as elgiloy, nitinol or MP35N, or other alloys which include nickel, titanium, tantalum, or stainless steel, high Co—Cr alloys or other temperature sensitive materials. For example, an alloy comprising Ni 15%, Co 40%, Cr 20%, Mo 7% and balance Fe may be used. The tensile strength of suitable wire is generally above about 300 Ksi and often between about 300 and about 340 Ksi for many embodiments. In one embodiment, a Chromium-Nickel-Molybdenum alloy such as that marketed under the name Conichrom (Fort Wayne Metals, Indiana) has a tensile strength ranging from 300 to 320 K psi, elongation of 3.5-4.0%. The wire may be treated with a plasma coating and be provided with or without additional coatings such as PTFE, Teflon, Perlyne and drugs.

[0084] In addition to segment length and bend configuration, discussed above, another determinant of radial strength

is wire gauge. The radial strength, measured at 50% of the collapsed profile, preferably ranges from about 0.2 lb. to 0.8 lb., and generally from about 0.4 lb. to about 0.5 lb. or more. Preferred wire diameters in accordance with the present invention range from about 0.004 inches to about 0.020 inches. More preferably, the wire diameters range from about 0.006 inches to about 0.018 inches. In general, the greater the wire diameter, the greater the radial strength for a given wire layout. Thus, the wire gauge can be varied depending upon the application of the finished graft, in combination with/or separate from variation in other design parameters (such as the number of struts, or proximal bends **60** and distal bends **62** per segment), as will be discussed; A wire diameter of approximately 0.018 inches may be useful in a graft having four segments each having 2.5 cm length per segment, each segment having six struts intended for use in the aorta, while a smaller diameter such as 0.006 inches might be useful for a 0.5 cm segment graft having 5 struts per segment intended for the iliac artery. The length of cage **42** could be as long as about 28 cm.

[0085] In one embodiment of the present invention, the wire diameter is tapered from the proximal to distal ends. Alternatively, the wire diameter may be tapered incrementally or stepped down, or stepped up, depending on differing radial strength requirements along the length of the graft for each particular clinical application. In one embodiment, intended for the abdominal aortic artery, the wire has a cross-section of about 0.018 inches in the proximal zone **55** and the wire tapers down to a diameter of about 0.006 inches in the distal zone **59** of the graft **42**. End point dimensions and rates of taper can be varied widely, within the spirit of the present invention, depending upon the desired clinical performance.

[0086] Referring to **FIG. 3**, there is illustrated a plan view of a single formed wire used for rolling about a longitudinal axis to produce a four segment straight tubular wire support. The formed wire exhibits distinct segments, each corresponding to an individual tubular segment **54** in the tubular support (see **FIGS. 1 and 2**).

[0087] Each segment has a repeating pattern of proximal bends **60** connected to corresponding distal bends **62** by wall sections **64** which extend in a generally zig-zag configuration when the segment **54** is radially expanded. Each segment **54** is connected to the adjacent segment **54** through a connector **66**, except at the terminal ends of the graft. The connector **66** in the illustrated embodiment comprises two wall or strut sections **64** which connect a proximal bend **60** on a first segment **54** with a distal bend **62** on a second, adjacent segment **54**. The connector **66** may additionally be provided with a connector bend **68**, which may be used to impart increased radial strength to the graft and/or provide a tie site for a circumferentially extending suture.

[0088] Referring to **FIG. 4**, there is shown an enlarged view of the wire support illustrating a connector **66** portion between adjacent segments **54**. In the embodiment shown in **FIG. 4**, a proximal bend **60** comprises about a 180 degree arc, having a radial diameter of (w) (Ranging from 0.070 to 0.009 inches), depending on wire diameter followed by a relatively short length of parallel wire spanning an axial distance of d1. The parallel wires thereafter diverge outwardly from one another and form the strut sections **64**, or the proximal half of a connector **66**. At the distal end of the

strut sections **64**, the wire forms a distal bend **62**, preferably having identical characteristics as the proximal bend **60**, except being concave in the opposite direction. The axial direction component of the distance between the apices of the corresponding proximal and distal bends **60**, **62** on a given strut section **64** is referred to as (d) and represents the axial length of that segment. The total expanded angle defined by the bend **60** and the divergent strut sections **64** is represented by α . Upon compression to a collapsed state, such as when the graft is within the deployment catheter, the angle α is reduced to α' . In the expanded configuration, α is generally within the range of from about 35° to about 45° for a six apex section having an axial length of about 1.5 cm or 2 cm and a diameter of about 25 mm or 28 mm. The expanded circumferential distance between any two adjacent distal bends **62** (or proximal bends **60**) is defined as (s).

[0089] In general, the diameter W of each proximal bend **60** or distal bend **62** is within the range of from about 0.009 inches to about 0.070 inches depending upon the wire diameter. Diameter W is preferably as small as possible for a given wire diameter and wire characteristics. As will be appreciated by those of skill in the art, as the distance W is reduced to approach two times the cross-section of the wire, the bend **60** or **62** will exceed the elastic limit of the wire, and radial strength of the finished segment will be lost. Determination of a minimum value for W, in the context of a particular wire diameter and wire material, can be readily determined through routine experimentation by those of skill in the art.

[0090] As will be appreciated from **FIGS. 3 and 4**, the sum of the distances (s) in a plane transverse to the longitudinal axis of the finished graft will correspond to the circumference of the finished graft cage in that plane. For a given circumference, the number of proximal bends **60** or distal bends **62** is directly related to the distance (s) in the corresponding plane. Preferably, the finished graft in any single transverse plane will have from about 3 to about 10 (s) dimensions, preferably from about 4 to about 8 (s) dimensions and, more preferably, about 5 or 6 (s) dimensions for an aortic application. Each (s) dimension corresponds to the distance between any two adjacent bends **60-60** or **62-62** as will be apparent from the discussion herein. Each segment **54** can thus be visualized as a series of triangles extending circumferentially around the axis of the graft, defined by a proximal bend **60** and two distal bends **62** or the reverse.

[0091] In one embodiment of the type illustrated in **FIG. 4**, w is about $2.0 \text{ mm} \pm 1 \text{ mm}$ for a 0.018 inch wire diameter. D1 is about $3 \text{ mm} \pm 1 \text{ mm}$, and d is about $20 \text{ mm} \pm 1 \text{ mm}$. Specific dimensions for all of the foregoing variables can be varied considerably, depending upon the desired wire configuration, in view of the disclosure herein.

[0092] Referring to **FIGS. 5 and 6**, one or more apices **76** is provided with an elongated axial length d2, which permits the apex **76** to be wrapped around a corresponding portion **78** such as an apex of the adjacent segment to provide an interlocking link **70** between two axially adjacent cage segments. In one embodiment of the link **70** produced by the opposing apices **76** and **78** of **FIG. 6**, utilizing wire having a diameter from 0.012" to 0.018", d1 is generally within the range of from about 1 mm to about 4 mm and d2 is within the range of from about 5 mm to about 9 mm. In general, a

longer d2 dimension permits accommodation for greater axial travel of apex **78** with respect to **76**, as will be discussed, thereby permitting greater lateral flexibility of the graft. W1 is within the range of from about 3 mm to about 5 mm, and W2 is sufficiently less than W1 that the apex **76** can fit within the apex **78**. Any of a wide variety of specific apex configurations and dimensions can be utilized, as will be apparent to those of skill in the art in view of the disclosure herein. Regardless of the specific dimensions, the end of the apex **76** is advanced through the apex **78**, and folded back upon its self to hook the apex **78** therein to provide a link **70** in accordance with the present invention.

[0093] The resulting link **70** (see **FIGS. 7 and 8**) comprises a wall portion **71** extending in a first direction, substantially parallel to the axis of the graft, and a transverse portion **72** extending transverse to the axis of the graft. A return portion **73** extends generally in the opposite direction from the wall portion **71** to create a generally "U" shaped hook. In certain embodiments, a closing portion **74** is also provided, to minimize the risk of excessive axial compression of the wire cage. The foregoing structure produces a functionally closed aperture **77**, which receives the interlocking section **75** of the adjacent graft segment. Alternatively, see **FIG. 10**.

[0094] In general, the aperture **77** preferably has a width (as viewed in **FIG. 8**) in the radial graft direction of substantially equal to the radial direction dimension of the interlocking section **75**. In this embodiment, the interlocking section **75**, as well as the locking portion **71** and return portion **73** can be flattened in the radial direction, to minimize the transverse cross-section of the link **70**. In the axial direction, the aperture **77** is preferably greater than the axial direction dimension of the interlocking section **75**, to accommodate some axial movement of each adjoining tubular segment of the graft. The axial length of the aperture **77** is at least about 2 times, and preferably at least about 3 or 4 times the cross-section of the interlocking section **75**. The optimum axial length of the aperture **77** can be determined through routine experimentation by one of skill in the art in view of the intended clinical performance, taking into account the number of links **70** per transverse plane as well as the desired curvature of the finished graft.

[0095] **FIGS. 6A, 7A and 8A** illustrate an alternate configuration for the moveable link **70**. With this configuration, the radial expansion force will be higher.

[0096] **FIGS. 7B and 8B** illustrate another alternate configuration. This linkage has a better resistance to axial compression and disengagement. Referring to **FIGS. 7B and 8B**, the apex extends beyond closing portion **74** and into an axial portion **79** which extends generally parallel to the longitudinal axis of the graft. Provision of an axial extension **79** provides a more secure enclosure for the aperture **77** as will be apparent to those of skill in the art. The embodiments of **FIGS. 7B and 8B** also illustrate an enclosed aperture **83** on the opposing apex. The aperture **83** is formed by wrapping the apex in at least one complete revolution so that a generally circumferentially extending portion **81** is provided. Circumferential portion **81** provides a stop, to limit axial compressibility of the graft. The closed aperture **83** can be formed by winding the wire of the apex about a mandrel either in the direction illustrated in **FIG. 7B**, or the direction illustrated in **FIG. 7C**. The embodiment of **FIG. 7C** advan-

tageously provided only a single wire thickness through the aperture 77, thereby minimizing the wall thickness of the graft. This is accomplished by moving the crossover point outside of the aperture 77, as will be apparent from FIG. 7C.

[0097] The link 70 in accordance with the present invention is preferably formed integrally with the wire which forms the cage of the endovascular prosthesis. Alternatively, link 70 may be constructed from a separate material which is secured to the wire cage such as by soldering, suture, wrapping or the like.

[0098] The axial direction of the link 70 may also be varied, depending upon the desired performance characteristics of the graft. For example, the distal tips 76 of each link 70 may all face the same direction, such as proximal or distal with respect to the graft. See, for example, FIG. 5. Alternatively, one or more links in a given transverse plane of apices may face in a proximal direction, and one or more links in the same transverse plane may face in the opposite direction. See, for example, FIG. 9.

[0099] Regardless of the axial orientation of the link 70, at least one and preferably at least two links 70 are provided per transverse plane separating adjacent graft segments. In an embodiment having six apices per transverse plane, preferably at least two or three and in one embodiment all six opposing apex pairs are provided with a link 70. See FIG. 5.

[0100] The distribution of the interlocking link 70 throughout the wire cage can thus vary widely, depending upon the desired performance characteristics. For example, each opposing apex pair between adjacent tubular segments can be provided with a link 70. See FIG. 5. Alternatively, interlocking links 70 may be spaced circumferentially apart around the graft wall such as by positioning them at every second or third opposing apex pair.

[0101] The distribution of the links 70 may also be varied along the axial length of the graft. For example, a first zone at a proximal end of the graft and a second zone at a distal end of the graft may be provided with a relatively larger number of links 70 than a third zone in the central portion of the graft. In one embodiment, the transverse apex plane between the first and second tubular segments at the proximal end of the graft may be provided with a link 70 at each opposing apex pair. This has been determined by the present inventors to increase the radial strength of the graft, which may be desirable at the proximal (superior) end of the graft and possibly also at the distal end of the graft where resistance to leakage is an issue. A relatively lesser radial strength may be necessary in the central portion of the graft, where maintaining patency of the lumen is the primary concern. For this reason, relatively fewer links 70 may be utilized in a central zone, in an effort to simplify graft design as well as reduce collapse profile of the graft. See FIG. 12.

[0102] In one straight segment graft, having four graft segments, three transverse apex planes are provided. In the proximal apex plane, each opposing pair of apices is provided with a link 70. In the central transverse apex plane, three of the six apex pairs are provided with a links 70, spaced apart at approximately 120°. Substantially equal circumferential spacing of the link 70 is preferred, to provide relatively uniform resistance to bending regardless of graft position. The distal transverse apex plane may also be provided with a link 70 at each opposing apex pair.

[0103] The foregoing interlocking link 70 in accordance with the present invention can be readily adapted to both the straight segment grafts as discussed above, as well as to the bifurcated grafts discussed below.

[0104] The interlocking link 70 can be utilized to connect any of a number of independent graft segments in axial alignment to produce either a straight segment or a bifurcation graft. The interlocking link 70 may be utilized as the sole means of securing adjacent segments to each other, or may be supplemented by additional attachment structures such as metal loops, sutures, welds and others which are well understood in the art.

[0105] Referring to FIGS. 12A through 12C there is illustrated a further wire layout which allows a smaller collapsed profile for the vascular graft. In general, the embodiment of FIGS. 12A through 12C permits a series of links 70A and 70B to be staggered axially from one another as seen in FIGS. 12A and 12B. In this manner, adjacent links 70 do not lie in the same transverse plane, and permit a tighter nesting of the collapsed wire cage. Preferably, between each adjoining graft segment, at least a first group of links 70A is offset axially from a second group of links 70B. In a six apex graft, having a link 70 at each apex, for example, a first group of every other apex 70A may be positioned slightly proximally of a second group of every other apex 70B. Referring to FIG. 12C, this may be accomplished by extending an apex 76A by a d3 distance which is at least about 1.2 times and as large as 1.5 times or 2 times or more the distance d2. The corresponding apices 78 and 78A are similarly staggered axially, to produce the staggered interface between adjacent graft segments illustrated in FIG. 12A. Although a loop apex is illustrated in FIG. 12C as apex 78, any of the alternate apices illustrated herein can be utilized in the staggered apex embodiment of the invention. The zig-zag pattern produced by axially offset links 70A and 70B can reside in a pair of parallel transverse planes extending generally between adjacent segments of the graft. Alternatively, the zig-zag relationship between adjacent links 70A and 70B can spiral around the circumference of a graft in a helical pattern, as will be understood by those of skill in the art in view of the disclosure herein. The precise axial offset between adjacent staggered links 70A and 70B can be optimized by one of ordinary skill in the art through routine experimentation, taking into account the desired physical properties and collapsed profile of the graft.

[0106] Referring to FIGS. 13 and 14, a straight segment deployment device and method in accordance with a preferred embodiment of the present invention are illustrated. A delivery catheter 80, having a dilator tip 82, is advanced along guidewire 84 until the (anatomically) proximal end 50 of the collapsed endoluminal vascular prosthesis 88 is positioned between the renal arteries 32 and 34 and the aneurysm 40. The collapsed prosthesis in accordance with the present invention has a diameter in the range of about 2 to about 10 mm. Generally, the diameter of the collapsed prosthesis is in the range of about 3 to 6 mm (12 to 18 French). Preferably, the delivery catheter including the prosthesis will be 16 F, or 15 F or 14 F or smaller.

[0107] The prosthesis 88 is maintained in its collapsed configuration by the restraining walls of the tubular delivery catheter 80, such that removal of this restraint would allow the prosthesis to self expand. Radiopaque marker material

may be incorporated into the delivery catheter **80**, and/or the prosthesis **88**, at least at both the proximal and distal ends, to facilitate monitoring of prosthesis position. The dilator tip **82** is bonded to an internal catheter core **92**, as illustrated in **FIG. 14**, so that the internal catheter core **92** and the partially expanded prosthesis **88** are revealed as the outer sheath of the delivery catheter **80** is retracted.

[0108] As the outer sheath is retracted, the collapsed prosthesis **88** remains substantially fixed axially relative to the internal catheter core **92** and consequently, self-expands at a predetermined vascular site as illustrated in **FIG. 14**. Continued retraction of the outer sheath results in complete deployment of the graft. After deployment, the expanded endoluminal vascular prosthesis **88** has radially self-expanded to a diameter anywhere in the range of about 20 to 40 mm, corresponding to expansion ratios of about 1:2 to 1:20. In a preferred embodiment, the expansion ratios range from about 1:4 to 1:8, more preferably from about 1:4 to 1:6.

[0109] In addition to, or in place of, the outer sheath described above, the prosthesis **88** may be maintained in its collapsed configuration by a restraining lace, which may be woven through the prosthesis or wrapped around the outside of the prosthesis in the collapsed reduced diameter. Following placement of the prosthesis at the treatment site, the lace can be proximally retracted from the prosthesis thereby releasing it to self expand at the treatment site. The lace may comprise any of a variety of materials, such as sutures, strips of PTFE, FEP, polyester fiber, and others as will be apparent to those of skill in the art in view of the disclosure herein. The restraining lace may extend proximally through a lumen in the delivery catheter or outside of the catheter to a proximal control. The control may be a pull tab or ring, rotatable reel, slider switch or other structure for permitting proximal retraction of the lace. The lace may extend continuously throughout the length of the catheter, or may be joined to another axially moveable element such as a pull wire.

[0110] In general, the expanded diameter of the graft in accordance with the present invention can be any diameter useful for the intended lumen or hollow organ in which the graft is to be deployed. For most arterial vascular applications, the expanded size will be within the range of from about 10 to about 40 mm. Abdominal aortic applications will generally require a graft having an expanded diameter within the range of from about 20 to about 28 mm, and, for example, a graft on the order of about 45 mm may be useful in the thoracic artery. The foregoing dimensions refer to the expanded size of the graft in an unconstrained configuration, such as on the table. In general, the graft will be positioned within an artery having a slightly smaller interior cross-section than the expanded size of the graft. This enables the graft to maintain a slight positive pressure against the wall of the artery, to assist in retention of the graft during the period of time prior to endothelialization of the polymeric sleeve **44**.

[0111] The radial force exerted by the proximal segment **94** of the prosthesis against the walls of the aorta **30** provides a seal against the leakage of blood around the vascular prosthesis and tends to prevent axial migration of the deployed prosthesis. As discussed above, this radial force can be modified as required through manipulation of various design parameters, including the axial length of the segment

and the bend configurations. In another embodiment of the present invention, radial tension can be enhanced at the proximal, upstream end by increasing the wire gauge in the proximal zone. Wire diameter may range from about 0.001 to 0.01 inches in the distal region to a range of from about 0.01 to 0.03 inches in the proximal region.

[0112] An alternative embodiment of the wire layout which would cause the radial tension to progressively decrease from the proximal segments to the distal segments, involves a progressive or step-wise decrease in the wire gauge throughout the entire wire support, from about 0.01 to 0.03 inches at the proximal end to about 0.002 to 0.01 inches at the distal end. Such an embodiment may be used to create a tapered prosthesis. Alternatively, the wire gauge may be thicker at both the proximal and distal ends, in order to insure greater radial tension and thus, sealing capacity. Thus, for instance, the wire gauge in the proximal and distal segments may be about 0.01 to 0.03 inches, whereas the intervening segments may be constructed of thinner wire, in the range of about 0.001 to 0.01 inches.

[0113] Referring to **FIG. 15**, there is illustrated two alternative deployment sites for the endoluminal vascular prosthesis **42** of the present invention. For example, an aneurysm **33** is illustrated in the right renal artery **32**. An expanded endoluminal vascular prosthesis **42**, in accordance with the present invention, is illustrated spanning that aneurysm **33**. Similarly, an aneurysm **37** of the right common iliac **36** is shown, with a prosthesis **42** deployed to span the iliac aneurysm **37**.

[0114] Referring to **FIG. 16**, there is illustrated a modified embodiment of the endovascular prosthesis **96** in accordance with the present invention. In the embodiment illustrated in **FIG. 16**, the endovascular prosthesis **96** is provided with a wire cage **46** having six axially aligned segments **54**. As with the previous embodiments, however, the endovascular prosthesis **96** may be provided with anywhere from about 2 to about 10 or more axially spaced or adjacent segments **54**, depending upon the clinical performance objectives of the particular embodiment.

[0115] The wire support **46** is provided with a tubular polymeric sleeve **44** as has been discussed. In the present embodiment, however, one or more lateral perfusion ports or openings are provided in the polymeric sleeve **44**, such as a right renal artery perfusion port **98** and a left renal artery perfusion port **100** as illustrated.

[0116] Perfusion ports in the polymeric sleeve **44** may be desirable in embodiments of the endovascular prosthesis **96** in a variety of clinical contexts. For example, although **FIGS. 1 and 16** illustrate a generally symmetrical aneurysm **40** positioned within a linear infrarenal portion of the abdominal aorta, spaced axially apart both from bilaterally symmetrical right and left renal arteries and bilaterally symmetrical right and left common iliacs, both the position and symmetry of the aneurysm **40** as well as the layout of the abdominal aortic architecture may differ significantly from patient to patient. As a consequence, the endovascular prosthesis **96** may need to extend across one or both of the renal arteries in order to adequately anchor the endovascular prosthesis **96** and/or span the aneurysm **40**. The provision of one or more lateral perfusion ports or zones enables the endovascular prosthesis **96** to span the renal arteries while permitting perfusion therethrough, thereby preventing "stent

jailing” of the renals. Lateral perfusion through the endovascular prosthesis **96** may also be provided, if desired, for a variety of other arteries including the second lumbar, testicular, inferior mesenteric, middle sacral, and alike as will be well understood to those of skill in the art.

[0117] The endovascular prosthesis **96** is preferably provided with at least one, and preferably two or more radiopaque markers, to facilitate proper positioning of the prosthesis **96** within the artery. In an embodiment having perfusion ports **98** and **100** such as in the illustrated design, the prosthesis **96** should be properly aligned both axially and rotationally, thereby requiring the ability to visualize both the axial and rotational position of the device. Alternatively, provided that the delivery catheter design exhibits sufficient torque transmission, the rotational orientation of the graft may be coordinated with an indexed marker on the proximal end of the catheter, so that the catheter may be rotated and determined by an external indicium of rotational orientation to be appropriately aligned with the right and left renal arteries.

[0118] In an alternative embodiment, the polymeric sleeve **44** extends across the aneurysm **40**, but terminates in the infrarenal zone. In this embodiment, a proximal zone **55** on the prosthesis **96** comprises a wire cage **46** but no polymeric sleeve **44**. In this embodiment, the prosthesis **96** still accomplishes the anchoring function across the renal arteries, yet does not materially interfere with renal perfusion. Thus, the polymeric sleeve **44** may cover anywhere from about 50% to about 100% of the axial length of the prosthesis **96** depending upon the desired length of uncovered wire cage **46** such as for anchoring and/or lateral perfusion purposes. In particular embodiments, the polymeric sleeve **44** may cover within the range of from about 70% to about 80%, and, in one four segment embodiment having a single exposed segment, 75%, of the overall length of the prosthesis **96**. The uncovered wire cage **46** may reside at only a single end of the prosthesis **96**, such as for traversing the renal arteries. Alternatively, exposed portions of the wire cage **46** may be provided at both ends of the prosthesis such as for anchoring purposes.

[0119] In a further alternative, a two part polymeric sleeve **44** is provided. A first distal part spans the aneurysm **40**, and has a proximal end which terminates distally of the renal arteries. A second, proximal part of the polymeric sleeve **44** is carried by the proximal portion of the wire cage **46** which is positioned superiorly of the renal arteries. This leaves an annular lateral flow path through the side wall of the vascular prosthesis **96**, which can be axially aligned with the renal arteries, without regard to rotational orientation.

[0120] The axial length of the gap between the proximal and distal segments of polymeric sleeve **44** can be adjusted, depending upon the anticipated cross-sectional size of the ostium of the renal artery, as well as the potential axial misalignment between the right and left renal arteries. Although the right renal artery **32** and left renal artery **34** are illustrated in **FIG. 16** as being concentrically disposed on opposite sides of the abdominal aorta, the take off point for the right or left renal arteries from the abdominal aorta may be spaced apart along the abdominal aorta as will be familiar to those of skill in the art. In general, the diameter of the ostium of the renal artery measured in the axial direction along the abdominal aorta falls within the range of from about 7 mm to about 20 mm for a typical adult patient.

[0121] Prior art procedures presently use a 7 mm introducer (18 French) which involves a surgical procedure for introduction of the graft delivery device. Embodiments of the present invention can be constructed having a 16 French or 15 French or 14 French or smaller profile (e.g. 34 mm) thereby enabling placement of the endoluminal vascular prosthesis of the present invention by way of a percutaneous procedure. In addition, the endoluminal vascular prosthesis of the present invention does not require a post implantation balloon dilatation, can be constructed to have minimal axial shrinkage upon radial expansion.

[0122] Referring to **FIG. 17**, there is disclosed a schematic representation of the abdominal part of the aorta and its principal branches as in **FIG. 1**. An expanded bifurcated endoluminal vascular prosthesis **102**, in accordance with the present invention, is illustrated spanning the aneurysms **103**, **104** and **105**. The endoluminal vascular prosthesis **102** includes a polymeric sleeve **106** and a tubular wire support **107**, which are illustrated in situ in **FIG. 17**. The sleeve **106** and wire support **107** are more readily visualized in the exploded view shown in **FIG. 19**. The endoluminal prosthesis **102** illustrated and described herein depicts an embodiment in which the polymeric sleeve **106** is situated concentrically outside of the tubular wire support **107**. However, other embodiments may include a sleeve situated instead concentrically inside the wire support or on both of the inside and the outside of the wire support. Alternatively, the wire support may be embedded within a polymeric matrix which makes up the sleeve. Regardless of whether the sleeve **106** is inside or outside the wire support **107**, the sleeve may be attached to the wire support by any of a variety of means, as has been previously discussed.

[0123] The tubular wire support **107** comprises a primary component **108** for traversing the aorta and a first iliac, and a branch component **109** for extending into the second iliac. The primary component **108** may be formed from a continuous single length of wire, throughout both the aorta trunk portion and the iliac branch portion. See **FIGS. 19 and 20**. Alternatively, each iliac branch component can be formed separately from the aorta trunk portion. Construction of the graft from a three part cage conveniently facilitates the use of different gauge wire in the different components (e.g. 14 gauge main trunk and 10 gauge branch components).

[0124] The wire support **107** is preferably formed in a plurality of discrete segments, connected together and oriented about a common axis. In **FIG. 20**, Section A corresponds to the aorta trunk portion of the primary component **108**, and includes segments **1-5**. Segments **6-8** (Section B) correspond to the iliac branch portion of the primary component **108**.

[0125] In general, each of the components of the tubular wire support **107** can be varied considerably in diameter, length, and expansion coefficient, depending upon the intended application. For implantation within a typical adult, the aorta trunk portion (section A) of primary component **108** will have a length within the range of from about 5 cm to about 12 cm, and, typically within the range of from about 9 cm to about 10 cm. The unconstrained outside expanded diameter of the section A portion of the primary component **108** will typically be within the range of from about 20 mm to about 40 mm. The unconstrained expanded outside diameter of the section A portion of primary component **108** can

be constant or substantially constant throughout the length of section A, or can be tapered from a relatively larger diameter at the proximal end to a relatively smaller diameter at the bifurcation. In general, the diameter of the distal end of section A will be on the order of no more than about 95% and, preferably, no more than about 85% of the diameter of the proximal end of section A.

[0126] The right and left iliac portions, corresponding to section B on primary component 108 and section C will typically be bilaterally symmetrical. Section C length will generally be within the range of from about 1 cm to about 5 cm, and section C diameter will typically be within the range of from about 10 mm to about 20 mm.

[0127] Referring to FIG. 19, the wire cage 107 is dividable into a proximal zone 110, a central zone 111 and a distal zone 112. As has been discussed, the wire cage 107 can be configured to taper from a relatively larger diameter in the proximal zone 110 to a relatively smaller diameter in the distal zone 112. In addition, the wire cage 107 can have a transitional tapered and or stepped diameter within a given zone.

[0128] Referring to FIG. 20, there is illustrated a plan view of the single formed wire used for rolling about a longitudinal axis to produce a primary segment 108 having a five segment aorta section and a three segment iliac section. The formed wire exhibits distinct segments, each corresponding to an individual tubular segment in the tubular support. Additional details of the wire cage layout and construction can be found in U.S. Pat. No. 6,077,296 entitled Endoluminal Vascular Prosthesis, filed Mar. 4, 1998, the disclosure of which is incorporated in its entirety herein by reference.

[0129] Each segment has a repeating pattern of proximal bends 60 connected to corresponding distal bends 62 by wall sections 64 which extend in a generally zig-zag configuration when the segment is radially expanded, as has been discussed in connection with FIG. 3. Each segment is connected to the adjacent segment through a connector 66, and one or more links 70 as has been discussed in connection with FIGS. 5-12. The connector 66 in the illustrated embodiment comprises two wall sections 64 which connect a proximal bend 60 on a first segment with a distal bend 62 on a second, adjacent segment. The connector 66 may additionally be provided with a connector bend 68, which may be used to impart increased radial strength to the graft and/or provide a tie site for a circumferentially extending suture.

[0130] In the illustrated embodiment, section A is intended for deployment within the aorta whereas section B is intended to be deployed within a first iliac. Thus, section B will preferably have a smaller expanded diameter than section A. This may be accomplished by providing fewer proximal and distal bends 60, 62 per segment in section B or in other manners as will be apparent to those of skill in the art in view of the disclosure herein. In the illustrated embodiment, section B has one fewer proximal bend 60 per segment than does each segment in section A. This facilitates wrapping of the wire into a tubular prosthesis cage such as that illustrated in FIG. 19, so that the iliac branch has a smaller diameter than the aorta branch. At the bifurcation, an opening remains for connection of the second iliac branch. The second branch is preferably formed from a section of

wire in accordance with the general principles discussed above, and in a manner that produces a similarly dimensioned wire cage as that produced by section B. The second iliac branch (section C) may be attached at the bifurcation to section A and/or section B in any of a variety of manners, to provide a secure junction therebetween. In one embodiment, one or two of the proximal bends 60 on section C will be secured to the corresponding distal bends 62 on the distal most segment of section A. Attachment may be accomplished such as through the use of a circumferentially threaded suture, through links 70 as has been discussed previously, through soldering or other attachment means. The attachment means will be influenced by the desirable flexibility of the graft at the bifurcation, which will in turn be influenced by the method of deployment of the vascular graft as will be apparent to those of skill in the art in view of the disclosure herein.

[0131] Referring to FIG. 21, there is disclosed an exploded schematic representation of a hinged or articulated variation in the tubular wire support structure for a bifurcated graft in accordance with present invention. The tubular wire support comprises a main body, or aortic trunk portion 200 and right 202 and left 204 iliac branch portions. Right and left designations correspond to the anatomic designations of right and left common iliac arteries. The proximal end 206 of the aortic trunk portion 200 has apexes 211-216 adapted for connection with the complementary apexes on the distal ends 208 and 210 of the right 202 and left 204 iliac branch portions, respectively. Complementary pairing of apexes is indicated by the shared numbers, wherein the right branch portion apexes are designated by (R) and the left branch portion apexes are designated by (L). Each of the portions may be formed from a continuous single length of wire. See FIG. 23.

[0132] Referring to FIG. 22, the assembled articulated wire support structure is shown. The central or medial apex 213 in the foreground (anterior) of the aortic trunk portion 200 is linked with 213(R) on the right iliac portion 202 and 213(L) on the left iliac portion 204. Similarly, the central apex 214 in the background (posterior) is linked with 214(R) on the right iliac portion 202 and 214(L) on the left iliac portion 204. Each of these linkages has two iliac apexes joined with one aortic branch apex. The linkage configurations may be of any of the variety described above in FIG. 7A-D. The medial most apexes 218 (R) and (L) of the iliac branch portions 202 and 204 are linked together, without direct connection with the aortic trunk portion 200.

[0133] The medial apexes 213 and 214 function as pivot points about which the right and left iliac branches 202, 204 can pivot to accommodate unique anatomies. Although the right and left iliac branches 202, 204 are illustrated at an angle of about 45° to each other, they are articulable through at least an angle of about 90° and preferably at least about 120°. The illustrated embodiment allows articulation through about 180° while maintaining patency of the central lumen. To further improve patency at high iliac angles, the apexes 213 and 214 can be displaced proximally from the transverse plane which roughly contains apexes 211, 212, 215 and 216 by a minor adjustment to the fixture about which the wire is formed. Advancing the pivot point proximally relative to the lateral apexes (e.g., 211, 216) opens the unbiased angle between the iliac branches 202 and 204.

[0134] In the illustrated embodiment, the pivot point is formed by a moveable link between an eye on apex 213 and two apices 213R and 213L folded therethrough. To accommodate the two iliac apices 213R and 213L, the diameter of the eye at apex 213 may be slightly larger than the diameter of the eye on other apices throughout the graft. Thus, for example, the diameter of the eye at apex 213 in one embodiment made from 0.014" diameter wire is about 0.059", compared to a diameter of about 0.020" for eyes elsewhere in the graft.

[0135] Although the pivot points (apices 213, 214) in the illustrated embodiment are on the medial plane, they may be moved laterally such as, for example, to the axis of each of the iliac branches. In this variation, each iliac branch will have an anterior and a posterior pivot link on or about its longitudinal axis, for a total of four unique pivot links at the bifurcation. Alternatively, the pivot points can be moved as far as to lateral apices 211 and 216. Other variations will be apparent to those of skill in the art in view of the disclosure herein.

[0136] To facilitate lateral rotation of the iliac branches 202, 204 about the pivot points and away from the longitudinal axis of the aorta trunk portion 200 of the graft, the remaining links between the aorta trunk portion 200 and the iliac branches 202, 204 preferably permit axial compression and expansion. In general, at least one and preferably several links lateral to the pivot point in the illustrated embodiment permit axial compression or shortening of the graft to accommodate lateral pivoting of the iliac branch. If the pivot point is moved laterally from the longitudinal axis of the aorta portion of the graft, any links medial of the pivot point preferably permit axial elongation to accommodate lateral rotation of the branch. In this manner, the desired range of rotation of the iliac branches may be accomplished with minimal deformation of the wire, and with patency of the graft optimized throughout the angular range of motion.

[0137] To permit axial compression substantially without deformation of the wire, the lateral linkages, 211 and 212 for the right iliac, and 215 and 216 for the left iliac, may be different from the previously described apex-to-apex linkage configurations. The lateral linkages are preferably slidable linkages, wherein a loop formed at the distal end of the iliac apex slidably engages a strut of the corresponding aortic trunk portion. The loop and strut orientation may be reversed, as will be apparent to those of skill in the art. Interlocking "elbows" without any distinct loop may also be used. Such an axially compressible linkage on the lateral margins of the assembled wire support structure allow the iliac branch portions much greater lateral flexibility, thereby facilitating placement in patients who often exhibit a variety of iliac branch asymmetries and different angles of divergence from the aortic trunk.

[0138] Referring to FIG. 23, there is illustrated a plan view of a single formed wire used for rolling about a longitudinal axis to produce a four segment straight tubular wire support for an iliac limb. The formed wire exhibits distinct segments, each corresponding to an individual tubular segment in the tubular supports 202 or 204 (See FIG. 21). The distal segment 1, is adapted to articulate with the aortic trunk portion 200 and the adjacent iliac limb portion. The distal segment (I) has two apices (e.g. corresponding to 211 and 212 on the right iliac portion 202 in FIG. 21) which

form a loop adapted to slidably engage a strut in the lateral wall of the aortic portion. These articulating loops (A) are enlarged in FIG. 24A. As discussed above, the loops are preferably looped around a strut on the corresponding apex of the proximal aortic segment to provide a sliding linkage.

[0139] The apex 218 is proximally displaced relative to the other four apices in the distal segment (I). Apex 218 (R or L) is designed to link with the complementary 218 apex on the other iliac branch portion (See FIG. 22). The apex 218 in the illustrated embodiment is formed adjacent or near an intersegment connector 66, which extends proximally from the distal segment.

[0140] The other apices on the distal segment (I) of an iliac limb are designed to link with a loop on the corresponding apex of the proximal aortic segment. Because many variations of this linkage are consistent with the present invention (See FIGS. 7A-D), the form of the corresponding apices may vary. In a preferred variation, the apices (B) form a narrow U-shape, having an inside diameter of about 0.019 inches in an embodiment made from 0.012 inch Conichrome wire (tensile strength 300 ksi minimum) as illustrated in FIG. 24B. The U-shaped, elongated axial portion of the apex shown in FIG. 24B permits the apex to be wrapped through and around a corresponding loop apex of the proximal aortic segment. This type of linkage is discussed in greater detail above in connection with FIGS. 5 and 6.

[0141] In more general terms, the wire support illustrated in FIGS. 21 and 22 comprises a main body support structure formed from one or more lengths of wire and having a proximal end, a distal end and a central lumen extending along a longitudinal axis. The wire support also comprises a first branch support structure formed from one or more lengths of wire and having a proximal end, a distal end and a central lumen therethrough. The first branch support structure is pivotably connected to the proximal end of the main body support structure. The tubular wire support further comprises a second branch support structure formed from one or more lengths of wire and having a proximal end, a distal end and a central lumen extending therethrough. The distal end of the second branch support structure is pivotably connected to the proximal end of the main body support structure.

[0142] Further, the distal ends of the first and second branch structures may be joined together by a flexible linkage, formed for example between apices 218(R) and 218(L) in FIG. 21. By incorporating a medial linkage between the two branch support structures and pivotable linkages with the main trunk, the first and second branch support structures can hinge laterally outward from the longitudinal axis without compromising the volume of the lumen. Thus, the branches may enjoy a wide range of lateral movement, thereby accommodating a variety of patient and vessel heterogeneity. Additional corresponding apices between the main trunk and each iliac branch may also be connected, or may be free floating within the outer polymeric sleeve. Axially compressible lateral linkages, discussed above and illustrated in FIG. 22, may optionally be added.

[0143] The proximal apices (C) of the iliac limb portions are adapted to link with the distal apices of the next segment. These proximal apices preferably form loops, such

as those illustrated in **FIG. 24C**, wherein the elongated axial portions of the corresponding proximal apex in the adjacent segment can wrap around the loop, thereby providing flexibility of the graft, as discussed above for **FIGS. 5 and 6**.

[0144] The wire may be made from any of a variety of different alloys and wire diameters or non-round cross-sections, as has been discussed. In one embodiment of the bifurcation graft, the wire gauge remains substantially constant throughout section A of the primary component **49** and steps down to a second, smaller cross-section throughout section B of primary component **108**.

[0145] A wire diameter of approximately 0.018 inches may be useful in the aorta trunk portion of a graft having five segments each having 2.0 cm length per segment, each segment having six struts intended for use in the aorta, while a smaller diameter such as 0.012 inches might be useful for segments of the graft having 6 struts per segment intended for the iliac artery.

[0146] In one embodiment of the present invention, the wire diameter may be tapered throughout from the proximal to distal ends of the section A and/or section B portions of the primary component **108**. Alternatively, the wire diameter may be tapered incremental or stepped down, or stepped up, depending on the radial strength requirements of each particular clinical application. In one embodiment, intended for the abdominal aortic artery, the wire has a cross-section of about 0.018 inches in the proximal zone **110** and the wire tapers down regularly or in one or more steps to a diameter of about 0.012 inches in the distal zone **112** of the graft **102**. End point dimensions and rates of taper can be varied widely, within the spirit of the present invention, depending upon the desired clinical performance.

[0147] In general, in the tapered or stepped wire embodiments, the diameter of the wire in the iliac branches is no more than about 80% of the diameter of the wire in the aortic trunk. This permits increased flexibility of the graft in the region of the iliac branches, which has been determined by the present inventors to be clinically desirable.

[0148] The collapsed prosthesis in accordance with the present invention has a diameter in the range of about 2 to about 10 mm. Preferably, the maximum diameter of the collapsed prosthesis is in the range of about 3 to 6 mm (12 to 18 French). Some embodiments of the delivery catheter including the prosthesis will be in the range of from 18 to 20 or 21 French; other embodiments will be as low as 19 F, 16 F, 14 F, or smaller. After deployment, the expanded endoluminal vascular prosthesis has radially self-expanded to a diameter anywhere in the range of about 20 to 40 mm, corresponding to expansion ratios of about 1:2 to 1:20. In a preferred embodiment, the expansion ratios range from about 1:4 to 1:8, more preferably from about 1:4 to 1:6.

[0149] The self expandable bifurcation graft of the present invention can be deployed at a treatment site in accordance with any of a variety of techniques as will be apparent to those of skill in the art. One such technique is disclosed in copending patent application Ser. No. 08/802,478 entitled Bifurcated Vascular Graft and Method and Apparatus for Deploying Same, filed Feb. 20, 1997, the disclosure of which is incorporated in its entirety herein by reference.

[0150] A partial cross-sectional side elevational view of one deployment apparatus **120** in accordance with the

present invention is shown in **FIG. 25**. The deployment apparatus **120** comprises an elongate flexible multicomponent tubular body **122** having a proximal end **124** and a distal end **126**. The tubular body **122** and other components of this system can be manufactured in accordance with any of a variety of techniques well known in the catheter manufacturing field. Suitable materials and dimensions can be readily selected taking into account the natural anatomical dimensions in the iliacs and aorta, together with the dimensions of the desired percutaneous access site.

[0151] The elongate flexible tubular body **122** comprises an outer sheath **128** which is axially movably positioned upon an intermediate tube **130**. A central tubular core **132** is axially movably positioned within the intermediate tube **130**. In one embodiment, the outer tubular sheath comprises extruded PTFE, having an outside diameter of about 0.250" and an inside diameter of about 0.230". The tubular sheath **128** is provided at its proximal end with a manifold **134**, having a hemostatic valve **136** thereon and access ports such as for the infusion of drugs or contrast media as will be understood by those of skill in the art.

[0152] The outer tubular sheath **128** has an axial length within the range of from about 40" to about 55", and, in one embodiment of the deployment device **120** having an overall length of 110 cm, the axial length of the outer tubular sheath **128** is about 52 cm and the outside diameter is no more than about 0.250". Thus, the distal end of the tubular sheath **128** is located at least about 16 cm proximally of the distal end **126** of the deployment catheter **120** in stent loaded configuration.

[0153] As can be seen from **FIGS. 26 and 27-28**, proximal retraction of the outer sheath **128** with respect to the intermediate tube **130** will expose the compressed iliac branches of the graft, as will be discussed in more detail below.

[0154] A distal segment of the deployment catheter **120** comprises an outer tubular housing **138**, which terminates distally in an elongate flexible tapered distal tip **140**. The distal housing **138** and tip **140** are axially immovably connected to the central core **132** at a connection **142**.

[0155] The distal tip **140** preferably tapers from an outside diameter of about 0.225" at its proximal end to an outside diameter of about 0.070" at the distal end thereof. The overall length of the distal tip **140** in one embodiment of the deployment catheter **120** is about 3". However, the length and rate of taper of the distal tip **140** can be varied depending upon the desired trackability and flexibility characteristics. The distal end of the housing **138** is secured to the proximal end of the distal tip **140** such as by thermal bonding, adhesive bonding, and/or any of a variety of other securing techniques known in the art. The proximal end of distal tip **140** is preferably also directly or indirectly connected to the central core **132** such as by a friction fit and/or adhesive bonding.

[0156] In at least the distal section of the catheter, the central core **132** preferably comprises a length of hypodermic needle tubing. The hypodermic needle tubing may extend throughout the length catheter to the proximal end thereof, or may be secured to the distal end of a proximal extrusion as illustrated for example in **FIG. 22**. A central guidewire lumen **144** extends throughout the length of the

tubular central core **132**, having a distal exit port **146** and a proximal access port **148** as will be understood by those of skill in the art.

[0157] Referring to **FIGS. 26-28**, a bifurcated endoluminal graft **150** is illustrated in a compressed configuration within the deployment catheter **120**. The graft **150** comprises a distal aortic section **152**, a proximal ipsilateral iliac portion **154**, and a proximal contralateral iliac portion **156**. The aortic trunk portion **152** of the graft **150** is contained within the tubular housing **138**. Distal axial advancement of the central tubular core **132** will cause the distal tip **140** and housing **138** to advance distally with respect to the graft **150**, thereby permitting the aortic trunk portion **152** of the graft **150** to expand to its larger, unconstrained diameter. Distal travel of the graft **150** is prevented by a distal stop **158** which is axially immovably connected to the intermediate tube **130**. Distal stop **158** may comprise any of a variety of structures, such as an annular flange or component which is adhered to, bonded to or integrally formed with a tubular extension **160** of the intermediate tube **132**. Tubular extension **160** is axially movably positioned over the hypotube central core **132**.

[0158] The tubular extension **160** extends axially throughout the length of the graft **150**. At the proximal end of the graft **150**, a step **159** axially immovably connects the tubular extension **160** to the intermediate tube **130**. In addition, the step **159** provides a proximal stop surface to prevent proximal travel of the graft **150** on the catheter **120**. The function of step **159** can be accomplished through any of a variety of structures as will be apparent to those of skill in the art in view of the disclosure herein. For example, the step **159** may comprise an annular ring or spacer which receives the tubular extension **160** at a central aperture therethrough, and fits within the distal end of the intermediate tube **130**. Alternatively, the intermediate tube **130** can be reduced in diameter through a generally conical section or shoulder to the diameter of tubular extension **160**.

[0159] Proximal retraction of the outer sheath **128** will release the iliac branches **154** and **156** of the graft **150**. The iliac branches **154** and **156** will remain compressed, within a first (ipsilateral) tubular sheath **162** and a second (contralateral) tubular sheath **164**. The first tubular sheath **162** is configured to restrain the ipsilateral branch of the graft **150** in the constrained configuration, for implantation at the treatment site. The first tubular sheath **162** is adapted to be axially proximally removed from the iliac branch, thereby permitting the branch to expand to its implanted configuration. In one embodiment, the first tubular sheath **162** comprises a thin walled PTFE extrusion having an outside diameter of about 0.215" and an axial length of about 7.5 cm. A proximal end of the tubular sheath **162** is necked down such as by heat shrinking to secure the first tubular sheath **162** to the tubular extension **160**. In this manner, proximal withdrawal of the intermediate tube **130** will in turn proximally advance the first tubular sheath **162** relative to the graft **150**, thereby deploying the self expandable iliac branch of the graft **150**.

[0160] The second tubular sheath **164** is secured to the contralateral guidewire **166**, which extends outside of the tubular body **122** at a point **168**, such as may be conveniently provided at the junction between the outer tubular sheath **128** and the distal housing **138**. The second tubular sheath

164 is adapted to restrain the contralateral branch of the graft **150** in the reduced profile. In one embodiment of the invention, the second tubular sheath **164** has an outside diameter of about 0.215" and an axial length of about 7.5 cm. The second tubular sheath **164** can have a significantly smaller cross-section than the first tubular sheath **162**, due to the presence of the tubular core **132** and intermediate tube **130** within the first iliac branch **154**.

[0161] The second tubular sheath **164** is secured at its proximal end to a distal end of the contralateral guidewire **166**. This may be accomplished through any of a variety of securing techniques, such as heat shrinking, adhesives, mechanical interfit and the like. In one embodiment, the guidewire is provided with a knot or other diameter enlarging structure to provide an interference fit with the proximal end of the second tubular sheath **156**, and the proximal end of the second tubular sheath **156** is heat shrunk and/or bonded in the area of the knot to provide a secure connection. Any of a variety of other techniques for providing a secure connection between the contralateral guidewire **166** and tubular sheath **156** can readily be used in the context of the present invention as will be apparent to those of skill in the art in view of the disclosure herein. The contralateral guidewire **166** can comprise any of a variety of structures, including polymeric monofilament materials, braided or woven materials, metal ribbon or wire, or conventional guidewires as are well known in the art.

[0162] In use, the free end of the contralateral guidewire **166** is percutaneously inserted into the arterial system, such as at a first puncture in a femoral artery. The contralateral guidewire is advanced through the corresponding iliac towards the aorta, and crossed over into the contralateral iliac in accordance with cross over techniques which are well known in the art. The contralateral guidewire is then advanced distally down the contralateral iliac where it exits the body at a second percutaneous puncture site.

[0163] The deployment catheter **120** is thereafter percutaneously inserted into the first puncture, and advanced along a guidewire (e.g. 0.035 inch) through the ipsilateral iliac and into the aorta. As the deployment catheter **120** is transluminally advanced, slack produced in the contralateral guidewire **166** is taken up by proximally withdrawing the guidewire **166** from the second percutaneous access site. In this manner, the deployment catheter **120** is positioned in the manner generally illustrated in **FIG. 29**. Referring to **FIG. 30**, the outer sheath **128** is proximally withdrawn while maintaining the axial position of the overall deployment catheter **120**, thereby releasing the first and second iliac branches of the graft **150**. Proximal advancement of the deployment catheter **120** and contralateral guidewire **166** can then be accomplished, to position the iliac branches of the graft **150** within the iliac arteries as illustrated.

[0164] Referring to **FIG. 31**, the central core **132** is distally advanced thereby distally advancing the distal housing **138** as has been discussed. This exposes the aortic trunk of the graft **150**, which deploys into its fully expanded configuration within the aorta. As illustrated in **FIG. 32**, the contralateral guidewire **166** is thereafter proximally withdrawn, thereby by proximally withdrawing the second sheath **164** from the contralateral iliac branch **156** of the graft **150**. The contralateral branch **156** of the graft **150** thereafter self expands to fit within the iliac artery. The

guidewire 166 and sheath 164 may thereafter be proximally withdrawn and removed from the patient, by way of the second percutaneous access site.

[0165] Thereafter, the deployment catheter 120 may be proximally withdrawn to release the ipsilateral branch 154 of the graft 150 from the first tubular sheath 162 as shown in FIG. 33. Following deployment of the ipsilateral branch 154 of the prosthesis 150, a central lumen through the aortic trunk 152 and ipsilateral branch 154 is sufficiently large to permit proximal retraction of the deployment catheter 120 through the deployed bifurcated graft 150. The deployment catheter 120 may thereafter be proximally withdrawn from the patient by way of the first percutaneous access site.

[0166] Referring to FIGS. 34a-34c, there is illustrated a flexible, straight graft design in accordance with a further aspect of the present invention. In this configuration, the wire cage may be flexed around a bend by allowing axial compression on an inside radius 227 compared to an outside radius 229, as seen in FIG. 34c. Axial compression on the inside radius 227 is enabled by the provision of a plurality of sliding links 220, one embodiment of which is illustrated in FIG. 34b. In general, the sliding link 220 enables the connection between a proximal bend 60 and a corresponding distal bend 62 to be compressible in the axial direction while maintaining the radial strength and radial expandability of the graft.

[0167] In the illustrated embodiment, this is accomplished by looping the proximal bend 60 around a wall section 64 which extends between a distal bend 62 and proximal bend 60 on a proximally adjacent segment of the graft. The proximal bend 60 is formed into a closed loop to form an aperture 61 for slidably entrapping the corresponding wall section 64. As used herein, the designations "proximal" and "distal" may be interchangeable when used, for example, to describe the relative position of the complementary sliding link structures on a graft. In addition, the proximal and distal designations are used sometimes herein with respect to the deployment catheter or deployment catheter direction, and other times in their anatomical sense with respect to the heart. The particular usage of these terms will be apparent to those of skill in the art in the context in which they are used herein.

[0168] Thus, referring to FIG. 34a, there is disclosed a flexible straight graft having a proximal end 50, and a distal end 52. The graft comprises a plurality of segments, such as a first segment 230, a second segment 232, a third segment 234, and a fourth segment 236. The adjacent segments can be formed separately or formed integrally such as from a single length of wire. All of the dimensions, materials and other design specifications which have been disclosed previously herein for both straight and bifurcated grafts may be provided with the sliding link design, and will therefore not be repeated. In general, however, the sliding link 220 is preferably provided on each of the connections between any two adjacent segments in a graft at which flexibility is desired, to permit the desired flexibility of the graft. For example, each of the connections between first segment 230 and second segment 232 may be provided with a sliding link 220. The connections between the intermediate segments 232 and 234 may be provided with either sliding links 220 or nonsliding links as have been disclosed elsewhere herein. The connections between the third segment 234 and fourth segment 236 may be provided with sliding links 220.

[0169] As illustrated in FIG. 34b, the sliding link 220 may slide along the wall section 64 all the way to the proximal bend 60. This range of motion may permit an undesirable degree of graft shortening or other disadvantages, and may not be necessary to achieve the radius of curvature likely to be encountered in the normal range of anatomical variation.

[0170] Referring to FIG. 34d, the axial travel of the sliding link 220 along the wall section 64 may be limited by the provision of a limit or lock 221. The lock 221 in the illustrated embodiment comprises a loop 223 of the wire from which wall section 64 is formed. The lock 221 may be provided anywhere between the distal bend 62 and the proximal bend 60, along the length of the wall section 64, depending upon the desired range of travel. The length of the wall section 64 in between the distal bend 62 and the lock 221 provides an axial compression range for the associated sliding link 220. The permitted range of travel for sliding link 220 may be varied depending upon the location of the sliding link 220 on the graft, and depending upon the desired radius of curvature for the graft in the implanted orientation.

[0171] The lock 221 may be formed as a single or double loop of the wire 64. Alternatively, the lock 221 may be separately formed and attached to the wall section 64 such as by soldering, brazing, adhesives, or by tying one or more knots in a suture or other material. A sliding link lock 221 may be provided for each sliding link 220 in a graft, or for only select sliding links 220, depending upon the desired clinical performance.

[0172] Referring to FIGS. 35a-35d, there is illustrated an embodiment of a bifurcation graft of the present invention in which sliding links 220 are utilized to increase the lateral flexibility of the proximal and distal ends of the graft, while axially noncompressible links are utilized for the central trunk of the graft. Referring to FIG. 35a, the bifurcation graft extends between a proximal end 50 and a distal end 52. In a proximal zone 55, which may comprise two or three or more adjacent segments, the connections between each proximal bend 60 and corresponding distal bend 62 is in the form of a sliding link 220. See FIG. 35b.

[0173] Throughout an intermediate zone 57, which may comprise the third, fourth, and fifth segments of the aortic trunk portion of the graft, axially noncompressible links are provided such as those disclosed elsewhere herein. See FIG. 35c.

[0174] The distal zone 59 of the graft, which, in the context of a bifurcation graft, includes a portion or all of the right and left iliac branches, comprises sliding links 220. See FIG. 35d. This assembly allows the maintenance of a certain axial (column strength) integrity while permitting the proximal end 50 and distal end 52 to adapt to curved or otherwise unusual anatomy. Sliding links 220 may alternatively be used throughout the length of the graft, or only at the connection of the proximal-most segment and/or the distal-most segment of the graft.

[0175] Referring to FIG. 36, there is illustrated a tapered graft design. This design is illustrated in the context of a bifurcation graft, although it can be readily adapted for use on a straight segment graft such as that illustrated in FIG. 1. It may be readily applied to any of the bifurcation grafts disclosed herein, including, for example, those of FIGS. 17-22.

[0176] In the illustrated embodiment, an aortic trunk 222 is connected to or formed with a right iliac branch 224 and a left iliac branch 226. At least a portion of the aortic trunk 222 is tapered from a larger unconstrained expanded diameter at the proximal end 50 to a smaller unconstrained expanded diameter at the bifurcation into right iliac 224 and left iliac 226. Although FIG. 36 illustrates a relatively uniform taper throughout the length of the aortic trunk portion 222, a nonuniform taper may also be utilized. For example, the first segment 230 and second segment 232 may be provided with a taper while the third segment 234, fourth segment, and fifth segment 238 may be relatively nontapered. Any of a wide variety of alternate configurations may be devised, depending upon the desired clinical performance and intended anatomy.

[0177] In the illustrated embodiment, the first segment 230 is provided with 10 proximal bends 60. The fifth segment 238 is provided with six proximal bends 60. By successively reducing the number of proximal bends 60 (and thus the number of zig-zag components to each segment), the tapered design can be achieved. The reduction in proximal bends 60, and thus diameter of the aortic trunk portion 222, from the first segment 230 to the fifth or other last segment 238 may be such that the number of proximal bends 60 in the last segment 238 is anywhere from about 40% to about 100% of the number of proximal bends 60 in the first segment 230. In some embodiments, the last segment 238 has anywhere from about 50% to about 80% and, in certain embodiments, about 60% of the number of proximal bends 60 in the first segment 230.

[0178] The foregoing structure may be provided in any of a variety of expanded diameters. In general, for an abdominal aortic aneurysm at the bifurcation of the iliacs, the maximum expanded diameter of the first segment 230 is preferably at least about 25 mm, and in many embodiments, at least about 30 mm. In one embodiment, the expanded diameter of the first segment 230 is at least about 34 mm. The expanded diameter of the graft at the bifurcation is generally within the range of from about 22 mm to about 28 mm, and, in one embodiment, is no more than about 25 mm.

[0179] In an alternate embodiment, the tapered expanded diameter configuration may be achieved by shaping the PTFE graft into a tapered configuration which constrains expansion of the wire cage. In this embodiment, each segment of the wire cage may have the same number of proximal bends 60. However, the constraint imposed by the PTFE sleeve may produce an unnecessary and potentially undesirable bunching of the zig-zag portions of the wire frame, particularly in the area of the last segment 238.

[0180] Referring to FIG. 37, there is illustrated a graft 250 which includes a feature which may be added onto any of the embodiments disclosed previously herein, to facilitate curvature of the graft. The precurved graft 250 may be straightened for mounting on the deployment catheter, but is configured in a manner that facilitates curvature as deployed.

[0181] The precurved graft 250 includes a plurality of segments 256 as has been discussed previously. Each segment 256 comprises a plurality of proximal bends 60 and distal bends 62 separated by wall sections 64. In previous embodiments, the axial length of the wall sections 64 within a given segment 256 have been generally the same. In the embodiment of FIG. 37, however, at least one wall section

64b in a given segment 256 has a shorter length than at least one wall section 64a on the same segment 256. In a graft segment 256 having, for example, 12 wall sections 64, generally from about 2 to about 6 wall sections 64b will have a shorter length than the remainder of the wall sections 64 in that segment 256.

[0182] Upon deployment, the wall sections 64b having the shorter length will limit elongation of the graft. The opposing wall sections 64a having a longer length will allow a plurality of sliding links to extend the length of the graft thereby enabling a curve, as illustrated, having a concave side 252 and a convex side 254.

[0183] In the illustrated embodiment, the overall curvature of the graft 250 is approximately 90°. Utilizing the differential length segments 256 of the present invention, grafts or graft sections may range from linear, to curved as much as 90° or 120 or more, including as much as 180° such as for use in exotic anatomies. This may be accomplished by providing sliding links on either or both of the convex side 254 and concave side 252 of the graft 250. In one embodiment, sliding links are provided on the convex side 254 and axially fixed links are provided on the concave side 252. This minimizes intrusion of the wire cage into the central lumen on the concave side 252 of the graft 250, which may otherwise occur upon axial compression of the graft on the concave side 252.

[0184] In accordance with a further feature of the present invention, a variety of modifications may be added to any of the grafts disclosed previously herein to increase resistance to migration and/or endoleaks, such as at the anatomically proximal end of the implanted graft. Thus, referring to FIG. 38a, a graft 42 is illustrated having a plurality of proximal bends 60 on the anatomically proximal end (distal device end) of the graft 42. One or more of the proximal bends 60 is provided with a radially outwardly inclined barb 260 for increasing resistance to migration of the graft 42 within the vessel. In an embodiment having eight proximal bends 60, preferably at least two, and in some embodiments as many as four or six or all eight of the proximal bends 60 is provided with a barb 260. Generally, at least about 50% of the proximal bends 60 or associated struts will be provided with a barb or tread 260.

[0185] As illustrated, each barb 260 is integrally formed with the support structure of the graft 42, such as by forming the barb 260 as a part of the wire cage. This eliminates the need for a separately attached component, which may become disengaged and/or increases the complexity of the manufacturing process.

[0186] Referring to FIG. 38b, the barb 260 may be formed by bending the proximal bend 60 radially outwardly at a bend point 262. The radial outwardly most tip of the barb 260 may be formed with or without a loop or eye as has been discussed. The bend 262 may be formed to cause the barb 260 to extend outwardly at an angle with respect to the longitudinal axis of the graft. The angle may range, in an unconstrained form, from anywhere within the range of from about 100 to about 160° from the longitudinal axis. In the illustrated embodiment, the bend 262 produces an angle of approximately 90°.

[0187] Although not illustrated in FIG. 38a, the barbs 260 may be offset from each other or staggered with respect to

the longitudinal axis of the graft **42**, to minimize the collapsed profile of the graft **42** when loaded on the deployment catheter. Staggering of the barbs **260** may be accomplished by positioning the barbs **260** such that no two barbs **260** are axially aligned in a single transverse plane upon collapse of the graft **42**. Alternatively, the barbs **260** may be alternated between a first transverse plane and a second transverse plane or a first, a second, and a third transverse plane as will be apparent to those of skill in the art in view of the disclosure herein. A similar staggering may be accomplished with respect to the plurality of links **258** in-between any adjacent segments in the graft, in any of the embodiments disclosed herein. This is illustrated in **FIG. 38a** in a stagger pattern such that about half of the links **258** in a given joint between adjacent graft segments reside in a first transverse plane and the other half reside in a second transverse plane. This permits a tighter nesting or lower crossing profile for the collapsed graft. This feature is independent of the barbs **260**, and either or both feature may be incorporated into any of the preceding embodiments.

[**0188**] A modified barb **260** is illustrated in **FIG. 38c**. In this embodiment, a portion of the wall sections **264** are bent in a first, radially inwardly inclined direction and then provided with a second bend to direct the tip of the barb **260** in a radially outwardly inclined direction. Other barb configurations can be readily achieved, as will be apparent to those of skill in the art in view of the disclosure herein.

[**0189**] A further feature of the present invention which may be provided on any of the embodiments discussed previously herein is illustrated in **FIGS. 39a-c**. In accordance with this feature, an exoskeleton **264** is provided at some point on the radially outwardly facing surface of the graft fabric, to facilitate endothelialization or other biological incorporation mechanism for providing resistance to migration of the implanted graft. The exoskeleton **264** is particularly useful in an embodiment wherein the fabric of the graft resists or does not permit tissue ingrowth.

[**0190**] Referring to **FIG. 39a**, each proximal bend **60** at the anatomically proximal end of the graft is connected by a generally V- or U-shaped partial exoskeleton segment **266**. The exoskeleton segment **266** may extend beyond the end of the fabric, or may be folded back on top of the fabric as illustrated in **FIG. 39a**. Each exoskeleton segment **266** terminates proximally in a bend **268** which may or may not include a loop or eye as has been discussed. The axial distance along the graft between the proximal bend **60** and adjacent exoskeleton bend **268** may be varied, depending upon the desired clinical performance. Generally, that axial distance is within the range of from about 1.5 cm to about 2.5 cm.

[**0191**] In addition, the plurality of bends **268** may be offset in the axial direction from a common transverse plane, to reduce the collapsed crossing profile of the graft as has been discussed. One or two or more of the bends **268** may be inclined radially outwardly and/or biased radially outwardly to resist migration.

[**0192**] A partial exoskeleton **264** may also be accomplished by leaving one or more adjacent apexes between adjacent graft segments unconnected from each other, and sliding the fabric of the graft beneath the unattached graft apex. This is illustrated, for example, in **FIG. 39b**. In the illustrated embodiment, alternating distal bends **62** from the

anatomically proximal-most graft segment remain on the outside of the graft fabric, while the remaining half of the distal bends **62** of the proximal-most graft segment remain connected to corresponding proximal bends **60** on the second to last graft segment.

[**0193**] In the second to last graft segment, the unattached proximal bends **60** may reside as illustrated in **FIG. 39b**, or it may be extended all the way to or near the proximal end of the graft, such as illustrated in **FIG. 39c**.

[**0194**] While a number of preferred embodiments of the invention and variations thereof have been described in detail, other modifications and methods of using and medical applications for the same will be apparent to those of skill in the art. Accordingly, it should be understood that various applications, modifications, and substitutions may be made of equivalents without departing from the spirit of the invention or the scope of the claims.

What is claimed is:

1. A tubular wire support for combination with a sheath to produce a bifurcated endoluminal prosthesis, said tubular wire support comprising:

a main body support structure having a proximal end, a distal end and a central lumen extending therethrough, the support structure comprising at least a first and second axially adjacent tubular segments, each segment comprising a plurality of wall struts connected by proximal and distal bends;

a first branch support structure having a proximal end, a distal end and a central lumen therethrough connected to the main body support structure;

a second branch support structure having a proximal end, a distal end and a central lumen extending therethrough, connected to the main body support structure;

at least two sliding links in between the first and second segments; and

at least one lock on a wall strut for limiting axial movement of a sliding link along that strut.

2. The tubular wire support of claim 1, wherein the main body support structure and the first and second branch support structures are self-expandable from a radially collapsed state to a radially expanded state.

3. A tubular wire support as in claim 2, wherein at least a portion of the tubular wire support has an expansion ratio of at least about 1:4.

4. The tubular wire support of claim 1, further comprising a tubular sheath on the wire support.

5. The tubular wire support of claim 4, wherein the sheath comprises a PTFE sleeve surrounding at least a central portion of the wire support.

6. The tubular wire support of claim 1, wherein each segment comprises wire formed into a series of proximal bends, a series of distal bends, and a series of struts connecting the proximal and distal bends.

7. The tubular wire support of claim 6, wherein each tubular segment comprises from about 4 proximal bends to about 12 proximal bends.

8. The tubular wire support of claim 1, wherein the first and second branch support structures are pivotably attached to the main body support structure.

9. A flexible self expandable graft, comprising:

a tubular main body support structure having a proximal end and a distal end, the tubular body comprising at least a first tubular segment attached to a second tubular segment; and

a tubular polymeric sleeve surrounding at least a portion of the graft;

wherein each of the first and second tubular segments comprise a plurality of proximal bends and distal bends connected by struts surrounding a longitudinal axis such that a first strut is on a first side of the axis and a second strut is on a second side of the axis, opposite to the first side, and in at least one segment the first strut is shorter than the second strut.

10. A flexible self expandable graft as in claim 9, further comprising at least a first and second sliding link between the first and second tubular segments.

11. A flexible self expandable graft as in claim 10, wherein the first and second sliding links join opposing proximal and distal bends on the first tubular segment and the second tubular segment.

12. A flexible self expandable graft as in claim 11, comprising at least four sliding links between the first and second segments.

13. A flexible self expandable graft as in claim 9, comprising at least four segments.

14. A flexible self expandable graft as in claim 11, comprising a series of struts connecting the proximal bends and distal bends within a segment to form a tubular segment wall, wherein at least some of the struts are substantially linear.

15. A flexible self expandable graft as in claim 14, wherein the sliding link comprises a proximal bend or distal bend on a first segment slidably engaged with a strut on an adjacent segment.

16. A flexible self expandable graft as in claim 11, wherein each segment comprises from about 4 proximal bends to about 12 proximal bends.

17. A flexible self expandable graft as in claim 11, having at least a proximal segment, an intermediate segment and a distal segment, wherein the prosthesis is expandable from a reduced cross section to an expanded cross section.

18. A flexible self expandable graft as in claim 17, wherein at least a portion of the proximal segment is larger in cross section than the central segment when the prosthesis is in the expanded cross section.

19. A flexible self expandable graft as in claim 11, wherein the sleeve comprises a tubular PTFE sleeve surrounding at least a portion of the prosthesis.

20. An endoluminal prosthesis, comprising at least one elongate flexible wire, formed into a plurality of axially adjacent tubular segments spaced along an axis, each tubular segment comprising a zig-zag section of wire, having a plurality of proximal bends and distal bends, at least one of the plurality of proximal bends and plurality of distal bends having loops thereon, and a tubular polymeric sleeve carried by the prosthesis, wherein the prosthesis is radially compressible into a first, reduced cross sectional configuration for implantation into a body lumen, and self expandable to a second, enlarged cross sectional configuration at a treatment site in a body lumen, and wherein at least a first portion of wire in one tubular segment is positioned on a radially outwardly facing surface of the sleeve and a radially inwardly facing surface of the sleeve is in contact with a second portion of wire.

21. An endoluminal prosthesis as in claim 20, comprising at least three segments formed from said wire.

22. An endoluminal prosthesis as in claim 20, wherein the prosthesis has a proximal end and a distal end, and at least one of the proximal end and distal end are expandable to a larger diameter than a central section of the prosthesis in an unconstrained expansion.

23. An endoluminal prosthesis as in claim 20, wherein the prosthesis has an expansion ratio of at least about 1:4.

24. An endoluminal prosthesis as in claim 23, wherein the prosthesis has an expansion ratio of at least about 1:5.

25. An endoluminal prosthesis as in claim 20, wherein the prosthesis has an expanded diameter of at least about 20 mm in an unconstrained expansion, and the prosthesis is implantable using a catheter no greater than about 20 French.

26. A prosthesis as in claim 25, wherein the prosthesis has an expanded diameter of at least about 25 mm, and is implantable on a delivery device having a diameter of no more than about 20 French.

27. An endoluminal prosthesis as in claim 20, comprising at least six proximal bends on a distal segment, wherein at least three of the proximal bends reside on the outside of the tubular sleeve and the remainder of the proximal bends on the distal segment are positioned on the inside of the tubular sleeve.

28. An endoluminal prosthesis as in claim 27, wherein the proximal bends on the inside of the tubular sleeve are connected to distal bends on a proximal segment.

29. A tubular wire support for a bifurcated endoluminal prosthesis, said wire support comprising:

a main body support structure having a proximal end, a distal end and a central lumen extending along a longitudinal axis therethrough;

a first branch support structure having a proximal end, a distal end and a central lumen therethrough, wherein the distal end of the first branch support structure is connected to the proximal end of the main body support structure;

a second branch support structure having a proximal end, a distal end and a central lumen extending therethrough wherein the distal end of the second branch support structure is connected to the proximal end of the main body support structure, and

a plurality of radially outwardly extending barbs on the main body, integrally formed on the wire support;

wherein the main body support structure and the first and second branch support structure are self-expandable from a radially collapsed state to a radially expanded state.

30. The tubular wire support of claim 29, further comprising a tubular sheath on the wire support.

31. The tubular wire support of claim 30, wherein the sheath comprises a PTFE sleeve surrounding at least a central portion of the wire support.

32. The tubular wire support of claim 29, wherein the wire in each support structure is formed into a plurality of segments, each segment comprising a series of proximal bends, a series of distal bends, and a series of struts connecting the proximal and distal bends.

33. The tubular wire support of claim 32 wherein each tubular segment comprises from about 4 proximal bends to about 12 proximal bends.