



- (51) International Patent Classification:
B65G 69/00 (2006.01)
- (21) International Application Number:
PCT/TR2018/050407
- (22) International Filing Date:
30 July 2018 (30.07.2018)
- (25) Filing Language: English
- (26) Publication Language: English
- (30) Priority Data:
2017/12778 25 August 2017 (25.08.2017) TR
- (71) Applicant: ORTA DOGU TEKNİK UNIVERSITESI
[TR/TR]; Eskisehir Yolu O.D.T.U. Yerleskesi, Sogutozu,
Ankara (TR).
- (72) Inventor: OZDEMIR, Ataman; ODTU Mimarlik Fakul-
tesi, 06800 Ankara (TR).
- (74) Agent: YALCINER, Ugur G. (YALCINER PATENT
& CONSULTING LTD.); Remzi Oguz Arik Mah. Tunus
Cad. No:85/3-4, 06680 Cankaya/Ankara (TR).

- (81) Designated States (unless otherwise indicated, for every
kind of national protection available): AE, AG, AL, AM,
AO, AT, AU, AZ, BA, BB, BG, BH, BN, BR, BW, BY, BZ,
CA, CH, CL, CN, CO, CR, CU, CZ, DE, DJ, DK, DM, DO,
DZ, EC, EE, EG, ES, FI, GB, GD, GE, GH, GM, GT, HN,
HR, HU, ID, IL, IN, IR, IS, JO, JP, KE, KG, KH, KN, KP,
KR, KW, KZ, LA, LC, LK, LR, LS, LU, LY, MA, MD, ME,
MG, MK, MN, MW, MX, MY, MZ, NA, NG, NI, NO, NZ,
OM, PA, PE, PG, PH, PL, PT, QA, RO, RS, RU, RW, SA,
SC, SD, SE, SG, SK, SL, SM, ST, SV, SY, TH, TJ, TM, TN,
TR, TT, TZ, UA, UG, US, UZ, VC, VN, ZA, ZM, ZW.
- (84) Designated States (unless otherwise indicated, for every
kind of regional protection available): ARIPO (BW, GH,
GM, KE, LR, LS, MW, MZ, NA, RW, SD, SL, ST, SZ, TZ,
UG, ZM, ZW), Eurasian (AM, AZ, BY, KG, KZ, RU, TJ,
TM), European (AL, AT, BE, BG, CH, CY, CZ, DE, DK,
EE, ES, FI, FR, GB, GR, HR, HU, IE, IS, IT, LT, LU, LV,
MC, MK, MT, NL, NO, PL, PT, RO, RS, SE, SI, SK, SM,
TR), OAPI (BF, BJ, CF, CG, CI, CM, GA, GN, GQ, GW,
KM, ML, MR, NE, SN, TD, TG).

(54) Title: NONDISCRIMINATORY ACCESS SYSTEM FOR PUBLIC/COLLECTIVE LIVING SPACES

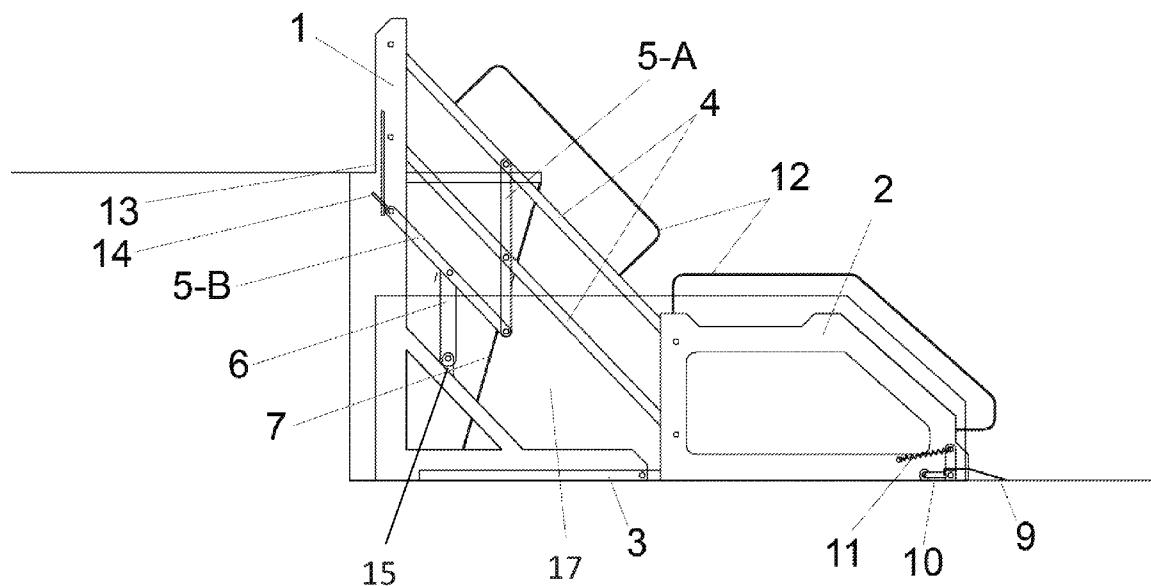

Figure - 1

(57) Abstract: The invention is related to a "nondiscriminatory access system for public/collective living spaces" which eases the access problems for the disabled without asking for assistance in said public/collective living spaces, where the boarding platform is higher or lower than the ground level.



Published:

- *without international search report and to be republished upon receipt of that report (Rule 48.2(g))*
- *in black and white; the international application as filed contained color or greyscale and is available for download from PATENTSCOPE*

NONDISCRIMINATORY ACCESS SYSTEM FOR PUBLIC/ COLLECTIVE LIVING SPACES

Technical Field

5 The invention is related to a “nondiscriminatory access system for public/collective living spaces” which eases the access problems for the disabled without getting outside assistance, in public/collective living spaces, where the boarding platform is higher or lower than the ground level.

Prior Art

10 Climbing up and down from the lower level to the upper level where there is an elevation difference is extremely difficult especially for people who use wheelchairs or crutches, who have difficulty in walking and who are visually impaired. Even though solutions for passage from the lower level to the upper level, such as staircases are provided for people who are not disabled, these solutions are not applicable for the disabled and such
15 staircases cause serious problems when used.

 Today in the known state of the art, for the passage of non-disabled people from the lower level to the upper level;

- ramps
- elevators
- 20 • stairs or escalators

are used.

 In the present systems, since the system is generally used by getting help from others when a disabled person desires to climb a stair level, the time loss causes various difficulties for both the disabled and the person who assists the disabled.

25 In addition, all other present systems are complicated and stationary systems whose mounting to the location is difficult and which have been produced with extra parts. At the same time, because of these are formed from extra parts, undesirable problems such as repair of extra parts can occur through time.

30

The Purpose and Brief Description of the Invention

In developing the nondiscriminatory access system, it is aimed to achieve an access system which can be assembled and disassembled at the location with ease, which provides convenience for the end user, which has a simple structure that can be used at any point
5 having an elevation difference, which is easy to use, which does not require frequent maintenance, which is durable against unforeseen loads and which has low cost of initial installation and during its operation.

The system developed according to the present invention is a system which can be assembled at any location with access problems and disassembled which provides
10 convenience for the end user. With the fewest parts as possible to produce, the mobility of the mechanism has been improved. One of the most important innovations of the system is that the disabled person does not need to get assistance from others in any way when he/she climbs up the floor. Additionally, the system convenient for carrying the entire load within the capacity of this system is designed with such a width that a stretcher can be
15 carried thereon. The system can also be used for carrying products or semi-products to the production line without interruption where there is an elevation difference in the production line in the industry. Along with all the other features it comprises, the system is one that can ease the disabled or non-disabled passenger and load transfer to all vehicles or to the port by being integrated to the port in maritime transport.

The most significant distinction of this system from the other solutions is that it is a
20 universal design and it is a system that can carry more than one disabled person, not just one disabled person and the people assisting them. Briefly, this system is suitable for use in transferring the disabled, patients, doctors, other assisting personnel and additionally all other loads.

25

Description of the Figures Illustrating the Invention

The figures and the related explanations used in order to better explain the nondiscriminatory access system developed by this invention is as follows.

Figure 1- Side view of the 1st application of the nondiscriminatory access system (Platform is
30 in the lower position)

Figure 2- Side view of the 1st application of the nondiscriminatory access system (Platform is in the middle position)

Figure 3- Side view of the 1st application of the nondiscriminatory access system (Platform is in the upper position)

Figure 4- Top view of the 1st application of the nondiscriminatory access system (Platform is in the upper position)

5 Figure 5- Side view of the 2nd application of the nondiscriminatory access system (Platform is in the lower position)

Figure 6- Side view of the 2nd application of the nondiscriminatory access system (Platform is in the middle position)

10 Figure 7- Side view of the 2nd application of the nondiscriminatory access system (Platform is in the upper position)

Figure 8- Side view of the 3rd application of the nondiscriminatory access system (Platform is in the lower position)

Figure 9- Side view of the 3rd application of the nondiscriminatory access system (Platform is in the middle position)

15 Figure 10- Side view of the 3rd application of the nondiscriminatory access system (Platform is in the upper position)

Figure 11- Side view of the 4th application of the nondiscriminatory access system (Platform is in the lower position)

20 Figure 12- Side view of the 4th application of the nondiscriminatory access system (Platform is in the middle position)

Figure 13- Side view of the 4th application of the nondiscriminatory access system (Platform is in the upper position)

Figure 14- Side view of the 5th application of the nondiscriminatory access system (Platform is in the lower position)

25 Figure 15- Side view of the 5th application of the nondiscriminatory access system (Platform is in the middle position)

Figure 16- Side view of the 5th application of the nondiscriminatory access system (Platform is in the upper position)

Description of the Parts Forming the Invention

The pieces and parts in the figures used to better illustrate the nondiscriminatory access system developed by this invention are numbered and the reference of each number is listed below.

- 5 1- Loadbearing body (main frame/main construction)
- 2- Platform side brackets
- 3- Platform
- 4- Parallel rods
- 5-A Power and motion transfer component
- 10 5-B Power and motion transfer component
- 6- Power supply
- 7- Back screen
- 8- Front screen
- 9- Ramp/stopper
- 15 10- Ramp motion wheel
- 11- Return spring
- 12- Railings
- 13- Safety panel
- 14- Safety panel motion component
- 20 15- Connection
- 16- Switch levers
- 17- Protective panel

Detailed Description of the Invention

The basic principle of this invention is to develop a system which eases the access problems for the disabled individuals in all public areas, especially in the places where there is an elevation difference.

5 The most important elements (mandatory for the operation) of the nondiscriminatory disabled access system developed by this invention are as follows:

- A loadbearing body (main frame/main construction) (1), of which a specific part is fixed to the upper level of the levels having a height difference and a specific part is fixed to the lower level,
- 10 • A horizontal platform (3) on which the disabled vehicle will be driven,
- Platform side brackets (2) which take place on both sides of the horizontal platform (3) and prevent the disabled vehicle from swaying to the left or right during the operation of the system,
- Parallel rods (4) one end of which is mounted to the loadbearing body (main frame/main construction) (1) and the other end to the platform side brackets,
- 15 • Power and motion transfer component (5-A), one end of which is connected to one of the parallel rods (4) and from its middle part to the second of the parallel rods (4) and the other end is connected to the power and motion transfer component element numbered 5-B,
- 20 • Power and motion transfer component (5-B), one end of which is connected to the power and motion transfer component element numbered 5-A and the other end to the loadbearing body (1) (main frame/main construction),
- Power supply (6),
- Safety panel (13) which prevents the platform (3) from moving further than the required position of the platform as it moves from the lower position to the upper position,
- 25 • Safety panel motion component (14) which enables the movement of the safety panel,
- A fixed end connection (15) of a plunger to which the fixed end of the plunger is connected.

The other elements which constitute the operation of the nondiscriminatory disabled access system developed with this invention and provide these with security features are as follows;

- 5 • The back screen (7) and the front screen (8) which prevent foreign objects from entering the bottom of the platform when the system is in operation and which prevents the mechanism from being seen,
- A protective panel (17) which prevent foreign objects from entering the bottom of the platform from the side of the platform when the system is in operation,
- 10 • The ramp/ stopper (9) which enable the disabled to get on the platform together with his/her vehicle when the platform (3) is in the lower position and which prevents the disabled vehicle from moving backwards when the platform is moving,
- The ramp motion wheel (10) which prevents the ramp/stopper (9) from moving after the platform (3) moves from the lower position,
- 15 • The return spring (11) which enables the movement of the ramp motion wheel (10),
- Railings (12) that the disabled can hold on to and that prevent the disabled from falling.

The operation principle of the nondiscriminatory access system is as follows;

When the nondiscriminatory access system is at the lower position;

- 20 The user passes onto the platform (3) with the help of the ramp/stopper (9). The user activates the power supply (6) by pressing on the up button on the platform side bracket (2). In one embodiment of the invention, hydraulic/pneumatic plunger is used as the power supply (6). As can be seen in Figure 1,2 or 3, the fixed end of the plunger is fixed to the connection point (15) and the moving part is fixed to the power and motion transfer component (5-B). With the linear movement of the hydraulic/pneumatic plunger, the power and motion transfer components (5-A and 5-B) start to push the parallel rods (4) upward.
- 25 Since one end of each of the parallel rods (4) are fixed to the platform side brackets (2), the platform (3) departs from the ground. With the movement of the platform (3), under the influence of the tractive force of the return spring (11), the ramp/stopper (9) goes to the stopper position. When the system arrives at the upper level needed to be reached, the
- 30 safety panel motion component (14) moves the safety panel (13) and the distance control

switches are activated and they stop the system. Thereby, the level the user desires to climb up to is reached.

If there is no new use demand related to the use of the disabled access system when the platform (3) is at the upper position, after staying at the (adjustable) upper position for a period, it can gradually go down to the lower position without any intervention.

When the disabled person is at the upper level and the system is at the lower level, when the disabled person desires to go down, he/she calls the system up by pressing the button on the loadbearing body (main frame/main construction) (1).

When the nondiscriminatory access system is at the upper position;

When the user arrives at the platform (2), he/she activates the power supply (6) by pressing on the down button. With the linear movement of the hydraulic/pneumatic plunger, the power and motion transfer components (5-A and 5-B) parts start pulling the parallel rods (4) downward. Since one end of each of the parallel rods (4) are fixed to the platform side brackets (2), they move the platform (3) downwards parallel to the ground level with the downward movement of the parallel rods (4). At the same time, the safety panel motion component (14) moves the safety panel (13) downwards. When the disabled access system approaches the ground level, the ramp motion wheel (10) pulls the return spring (11) and enables the ramp/stopper (9) to be brought to the exit position, which is the ramp position. At this stage, the safety panel passes on to the barrier position. Distance control switches are activated at the exit point and the system is automatically stopped.

In order to keep from any inconvenience within the operation space of the disabled access system, the safe operation space of the system is defined with the help of boards on the side, the moving front screen (8) at the front and the safety panel at the arrival point.

In Figure-5, the 2nd application of the nondiscriminatory access system takes place. In this application, a plunger is used as the power supply (6). One end of the plunger is fixed to the loadbearing body (main frame/main construction) (1) and the other end to the switch levers (16). One rod of the switch levers (16) is fixed to the junction point of the power and motion transfer components (5-A and 5-B) and the other rod is fixed to the ground. When the system passes on to the upper position from the lower position, the plunger pushes the switch levers (16) and enables the power and motion transfer components (5-A and 5-B) to move upwards. The upward movement of the power and motion transfer components (5-A and 5-B) provide the upward movement of the parallel rods (4) and the upward movement

of the parallel rods (4) provides the upward movement of the platform (3) parallel to the ground.

In Figure 8, the 3rd application of the nondiscriminatory access system takes place. In this application, a plunger is used as the power supply (6). The fixed end of the plunger is fixed to the rod which is fixed to the ground from the switch levers (16) and the moving end of the plunger is fixed to the rod which is fixed to the power and motion transfer rod (5-A) from the switch levers (16). When the system passes on to the upper position from the lower position, the plunger pushes the switch levers (16) and provides for the power and motion transfer component (5-A) to move upwards. The upward movement of the power and motion transfer component (5-A) provide the upward movement of the parallel rods (4) and the upward movement of the parallel rods (4) provides the upward movement of the platform (3) parallel to the ground.

In Figure 11, the 4th application of the nondiscriminatory access system takes place. In this application, a plunger is used as the power supply (6). One of the switch levers (16) is fixed to the ground and the other end is fixed to the platform side brackets (2). The fixed end of the plunger is fixed to the side brackets (2) and the other end is to the rod which is fixed to the plunger side brackets (2) from the switch levers (16). When the system passes on to the upper position from the lower position, the plunger pushes the switch levers (16) and provides the upward movement of the platform (3). The upward movement of the platform (3) enables the parallel rods (4) to move upwards and the upward movement of the parallel rods (4) enables the upward movement of the power and motion transfer rods.

In Figure-15, the 5th application of the nondiscriminatory access system takes place. In this application, a plunger is used as the power supply (6). One of the switch levers (16) is fixed to the ground and the other rod is fixed to the platform side brackets (2). The fixed end of the plunger is fixed to the rod which is fixed to the ground from the switch levers and the moving end of the plunger is fixed to the rod which is fixed to the platform side brackets (2) from the switch levers. When the system passes on to the upper position from the lower position, the plunger pushes the plunger switch levers (16) and enables the upward movement of the platform (3). The upward movement of the platform (3) enables the parallel rods (4) to move upward and the upward movement of the parallel rods (4) enables the upward movement of the power and motion transfer rods.

As the power supply, instead of the plunger, any one of linear systems, eccentric rods, cam systems, screw systems, hydraulic or pneumatic cylinders, gear wheel systems, chain or gear steel cords can be used.

In one embodiment of the invention, remote control is used instead of the buttons which provide the up and down movement of the system.

CLAIMS

1. A nondiscriminatory disabled access system characterized in that it comprises;

- 5 • A loadbearing body (main frame/main construction) (1), a specific part of which is fixed to the upper level of the levels having a height difference and a specific part to the lower level,
- A horizontal platform (3) the disabled vehicle will be driven on,
- Platform side brackets (2) which take place on both sides of the horizontal platform (3) and prevent the disabled vehicle from swaying to the left or right during the operation of the system,
- 10 • Parallel rods (4) one end of which is mounted to the loadbearing body (main frame/main construction) (1) and the other end to the platform side brackets,
- A power and motion transfer component (5-A), one end of which is connected to one of the parallel rods (4) and from its middle part to the second of the parallel rods (4) and the other end is connected to the power and motion transfer component element numbered 5-B,
- 15 • A power and motion transfer component (5-B), one end of which is connected to the power and motion transfer component element numbered 5-A and the other end to the loadbearing body (1) (main frame/main construction),
- 20 • A Power supply (6),
- A safety panel (13) which prevents the platform (3) from moving further than the required position of the platform as it moves from the lower position to the upper position,
- A safety panel motion component (14) which enables the movement of the safety panel.
- 25

2. A disabled access system according to Claim 1, characterized in that is comprises;

- A back screen (7) and a front screen (8) which prevent foreign objects from entering the bottom of the platform when the system is in operation and which prevents the mechanism from being seen,
- 30

- A protective panel (17) which prevent foreign objects from entering the bottom of the platform from the side of the platform when the system is in operation,
 - A ramp/ stopper (9) which enables the disabled to get on the platform together with his/her vehicle when the platform (3) is in the lower position and which prevents the disabled vehicle from moving backwards when the platform is moving,
 - A ramp motion wheel (10) which prevents the ramp/stopper (9) from moving after the platform (3) moves from the lower position,
 - A return spring (11) which enables the movement of the ramp motion wheel (10),
 - Railings (12) that the disabled can hold onto and that prevent the disabled from falling, which also makes the operation of the disabled access system easier and which provides security features.
3. A disabled access system according to Claim 1, characterized in that the fixed end of the power supply (6) is fixed to the connection point (15) and the moving end is fixed to the power and motion transfer component (5-B).
4. A disabled access system according to Claim 1 or Claim 2, characterized in that a down direction button and an up direction button is provided on the platform side brackets (2).
5. A disabled access system according to Claim 1 or Claim 2, characterized in that it has a call button on the loadbearing body(main frame/main construction) (1) for the system to go up.
6. A disabled access system according to any one of the above claims characterized in that the power supply (6) is at least any one of a plunger, linear systems, eccentric rods, cam systems, screw systems, hydraulic or pneumatic cylinders, gear wheel systems, chain or gear steel cords.
7. A disabled access system according to any one of the preceding claims, characterized in that it comprises distance control switches which enable the system to move to the position the system is required to arrive at, as it goes up or down.

8. A disabled access system according to Claim 1, characterized in that it comprises switch levers (16) one rod of which is fixed to the junction point of the power and motion transfer components (5-A ve 5-B) and the other rod is fixed to the ground.
- 5 9. A disabled access system according to Claim 8, characterized in that the fixed end of the power supply (6) is fixed to the loadbearing body (main frame/main construction) (1) and the moving end is fixed to the rod which is fixed to the junction point of the power and motion transfer components (5-A ve 5-B) from the switch levers (16).
- 10 10. A disabled access system according to Claim 8, characterized in that the fixed end of the power supply (6) is fixed to the rod which is fixed to the ground from the switch levers (16) and the moving end is fixed to the junction point of the power and motion transfer components (5-A ve 5-B) from the switch levers (16).
- 15 11. A disabled access system according to Claim 1, characterized in that it comprises switch levers (16) one rod of which is fixed to the platform side brackets (2) and the other rod is fixed to the ground.
- 20 12. A disabled access system according to Claim 11, characterized in that the fixed end of the power supply (6) is fixed to the platform side brackets (2) and the moving end to the rod which is fixed to the side platform (2) from the switch levers (16).
- 25 13. A disabled access system according to Claim 11, characterized in that the fixed end of the power supply (6) is fixed to the rod which is fixed to the ground from the switch levers (16) and its moving end to the rod which is fixed to the side platform (2) from the switch levers (16).
- 30 14. A disabled access system according to any one of the preceding claims, characterized in that the up and down movement of the system is provided by a remote control.

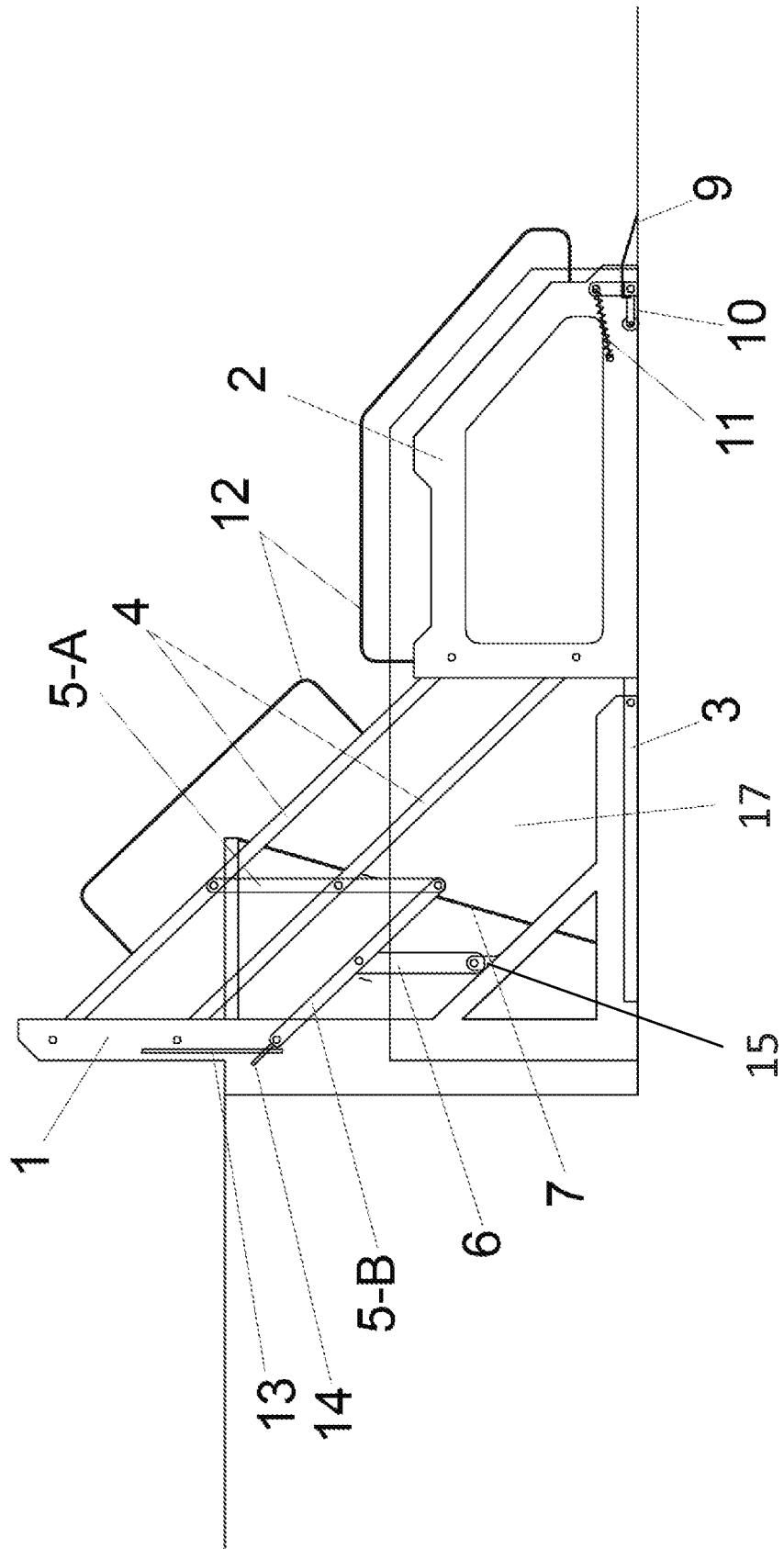

Figure - 1

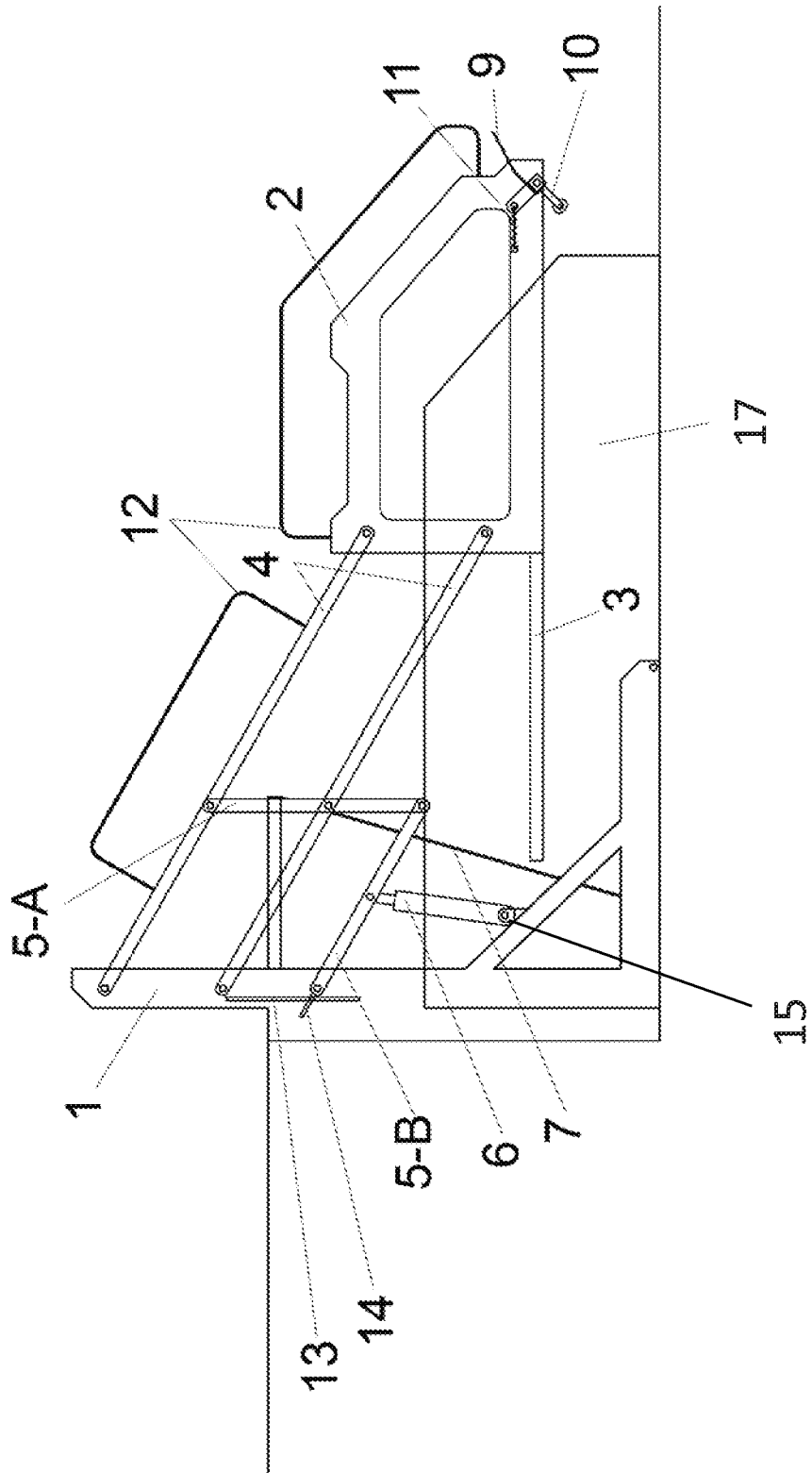

Figure - 2

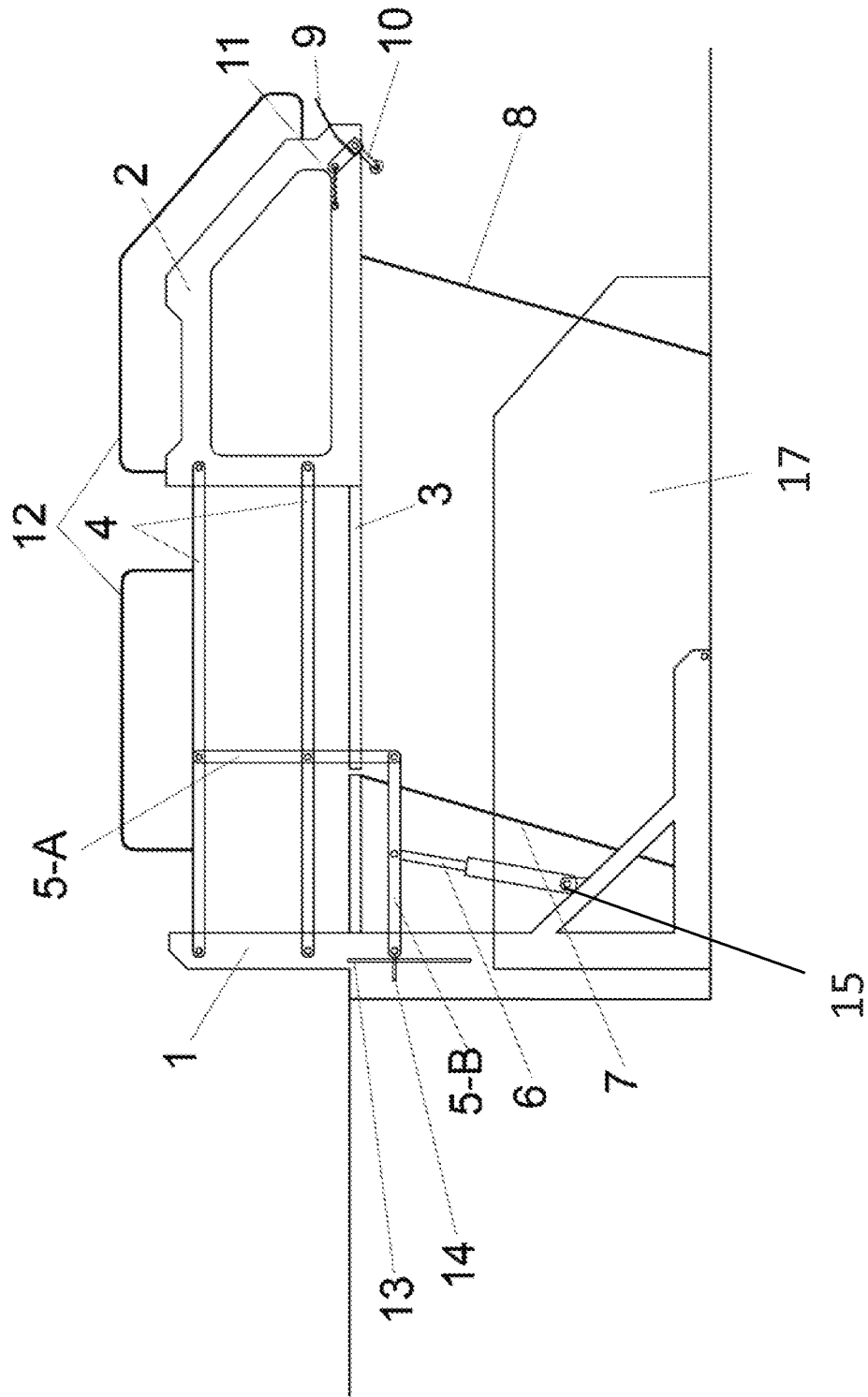

Figure - 3

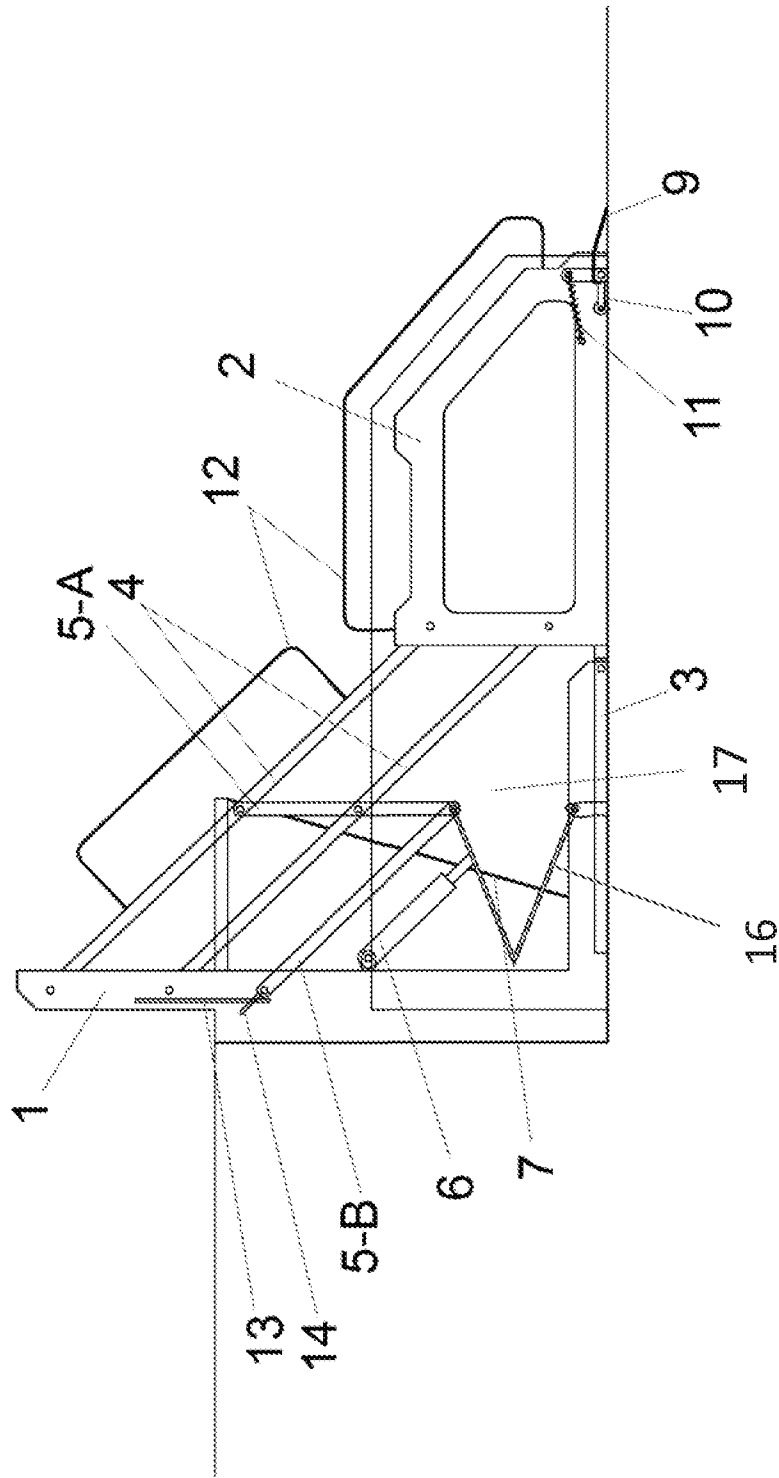

Figure - 5

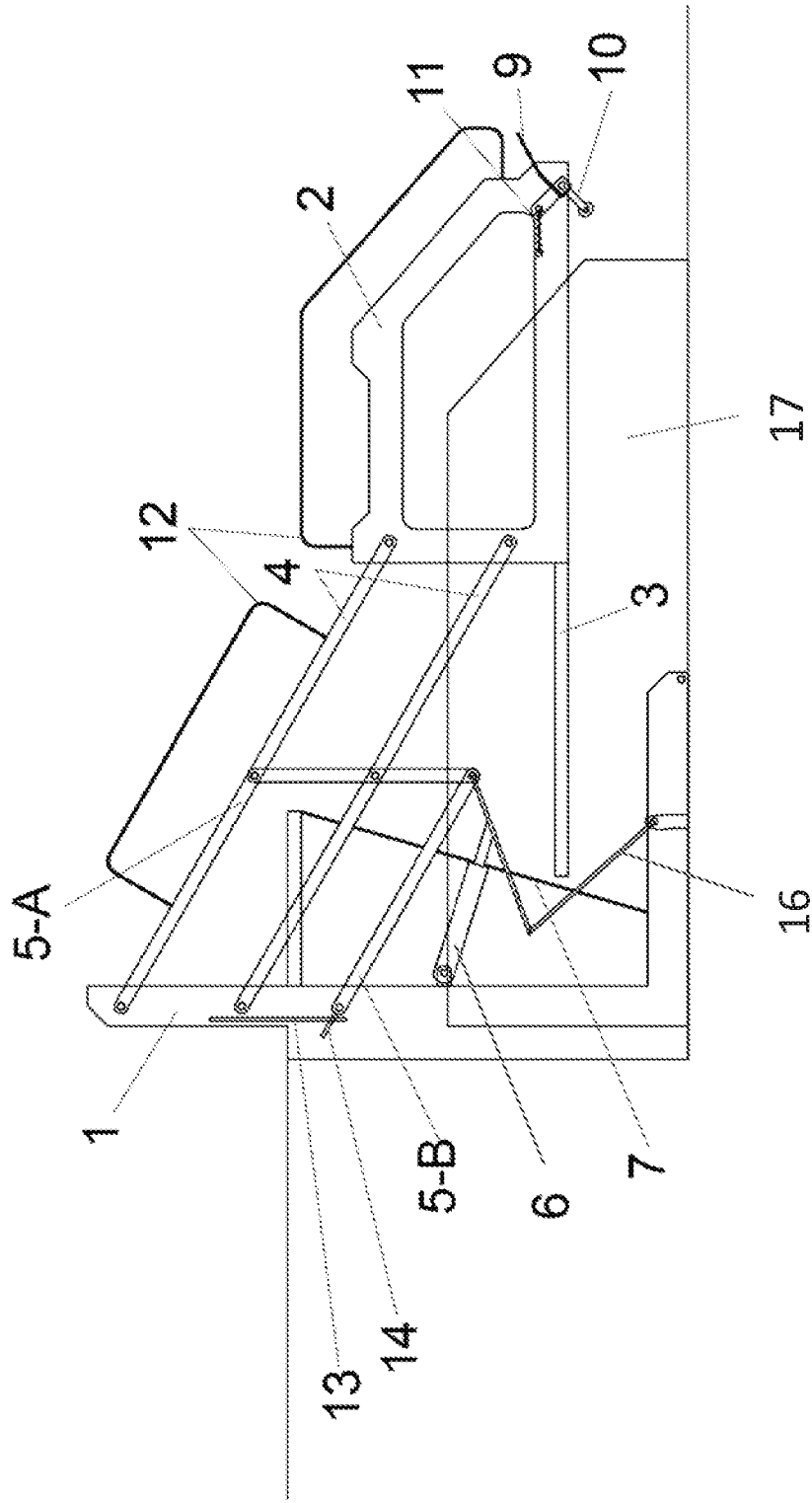

Figure - 6

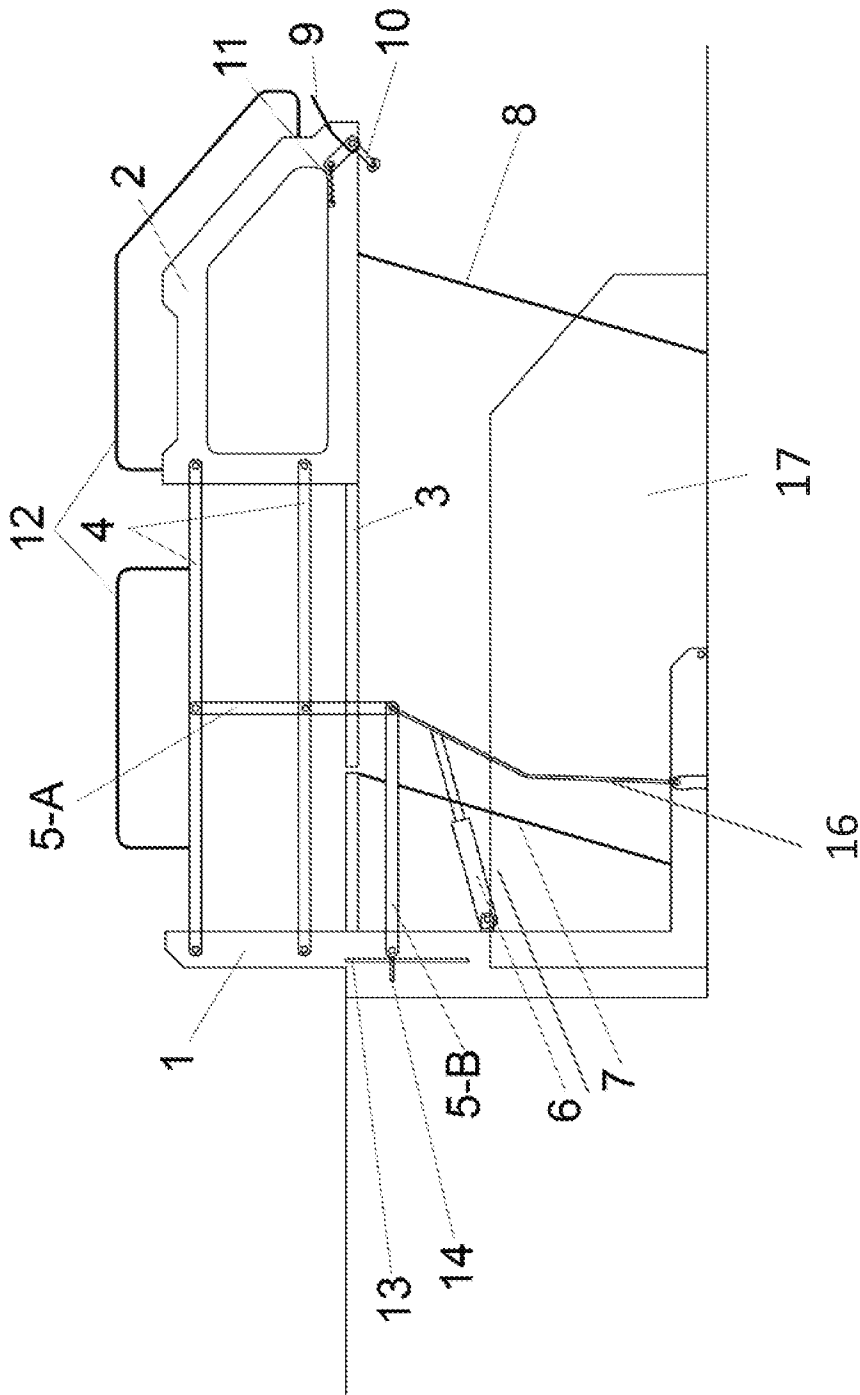

Figure - 7

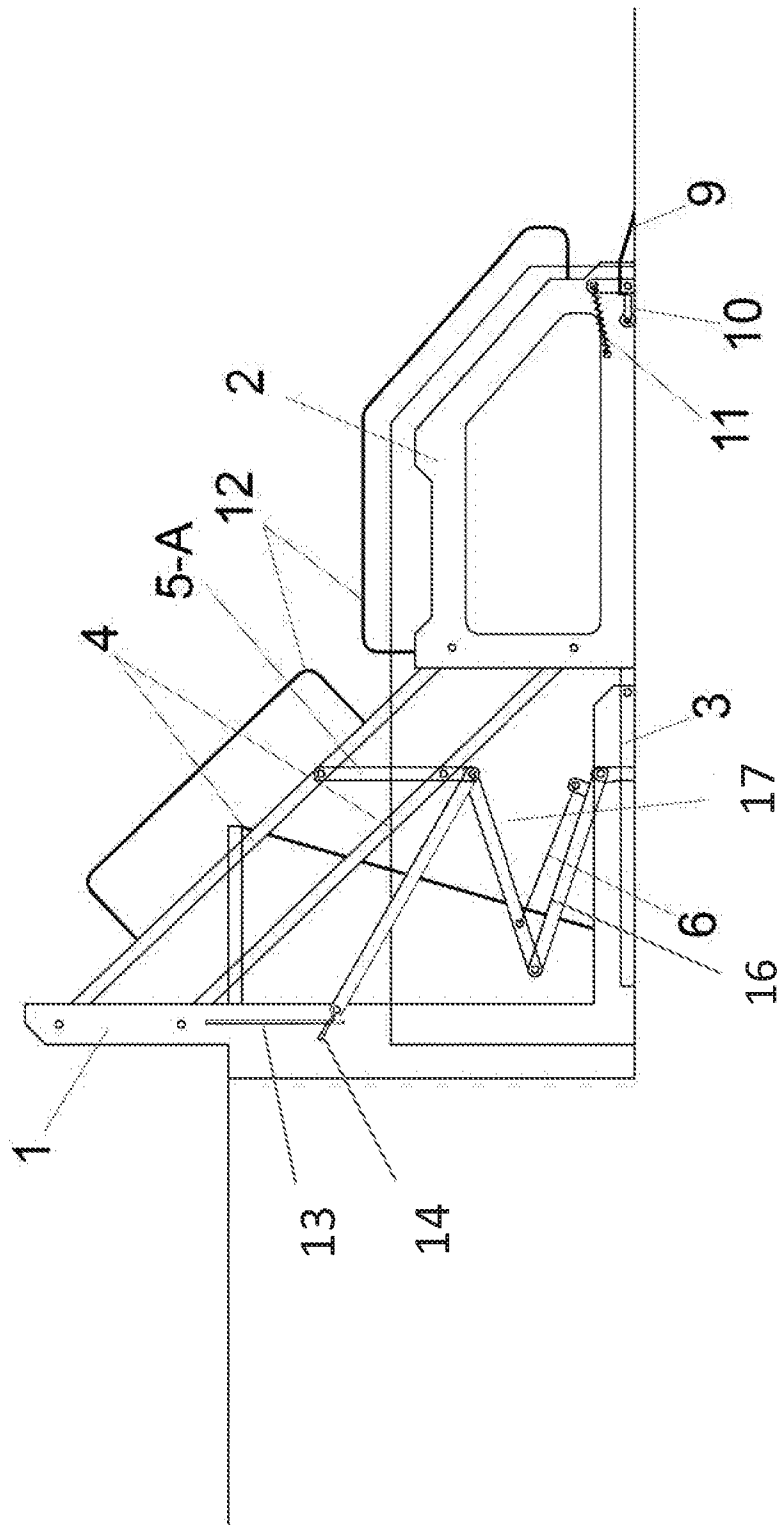

Figure - 8

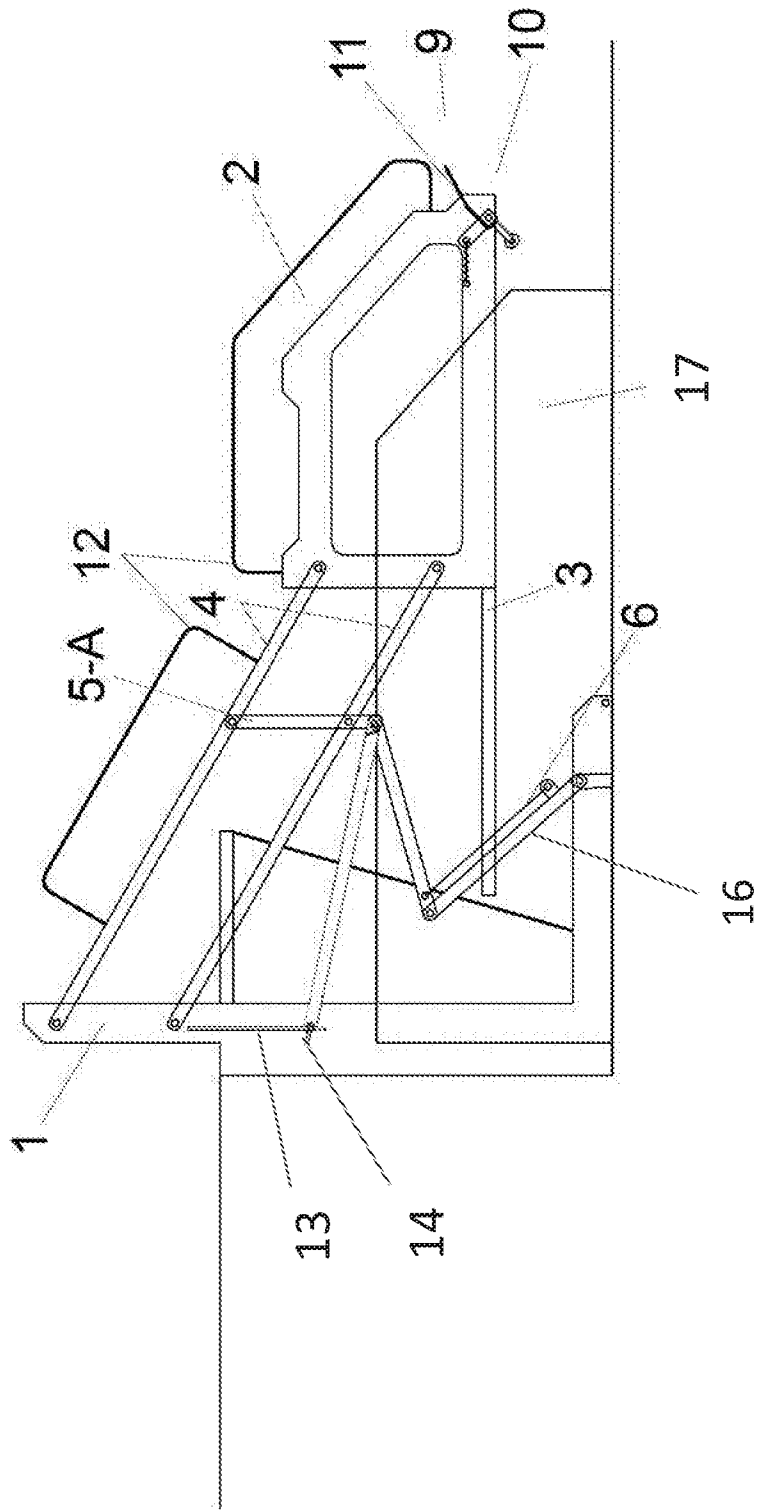

Figure - 9

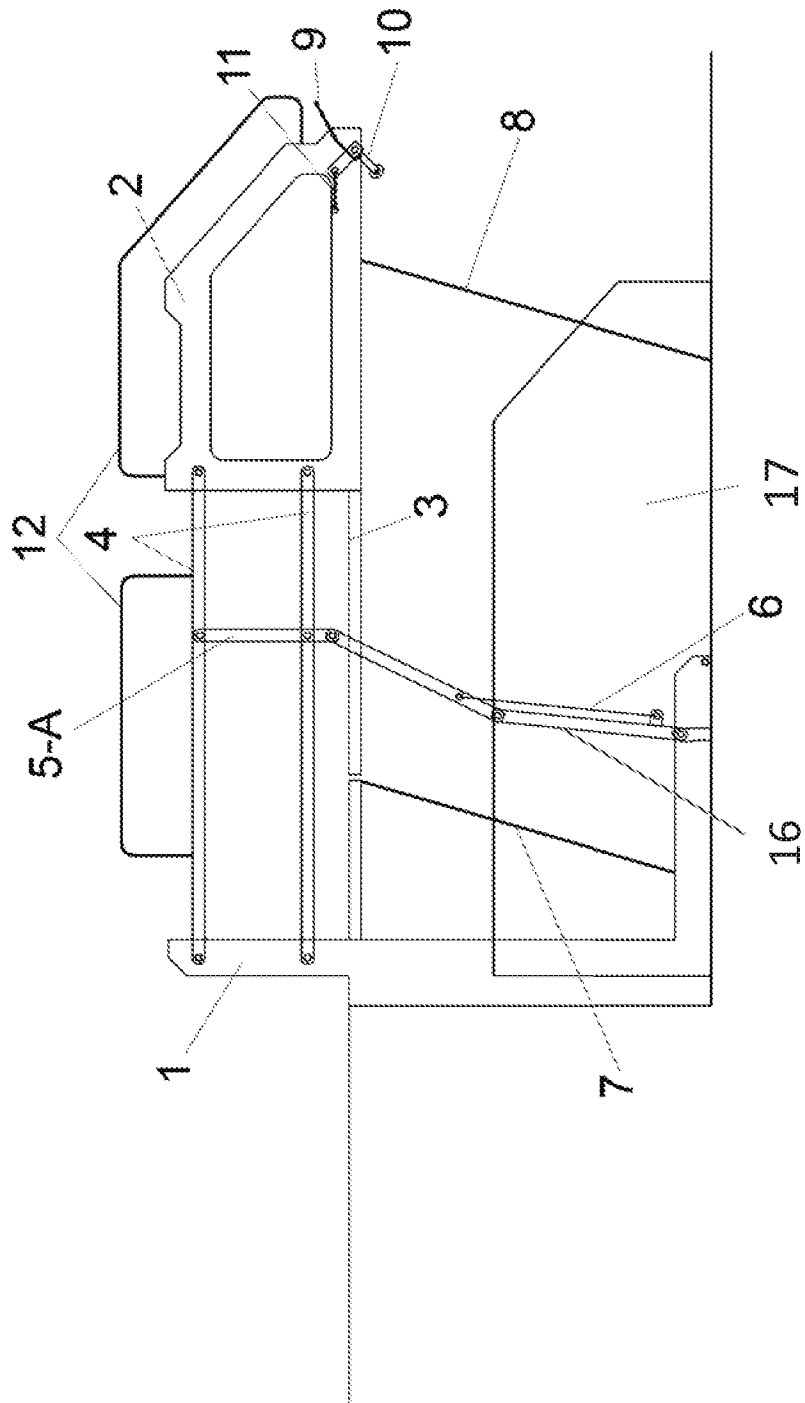

Figure - 10

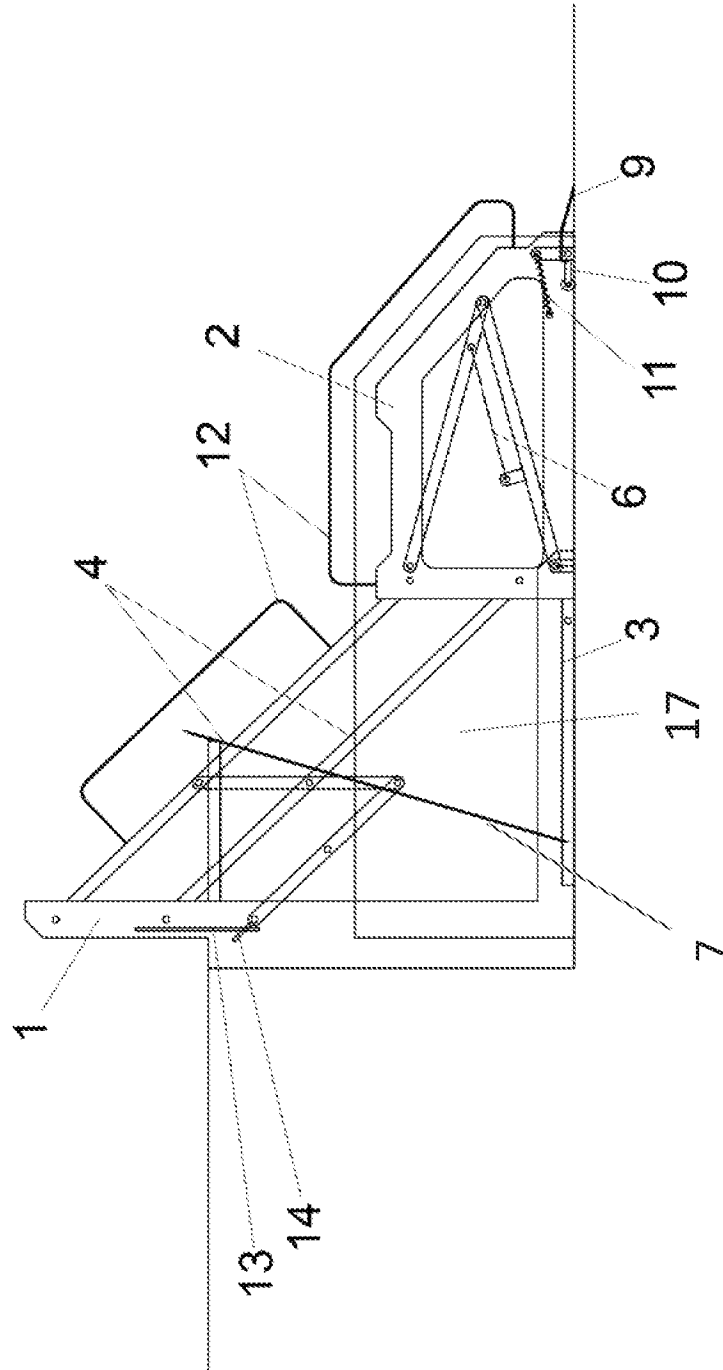

Figure - 11

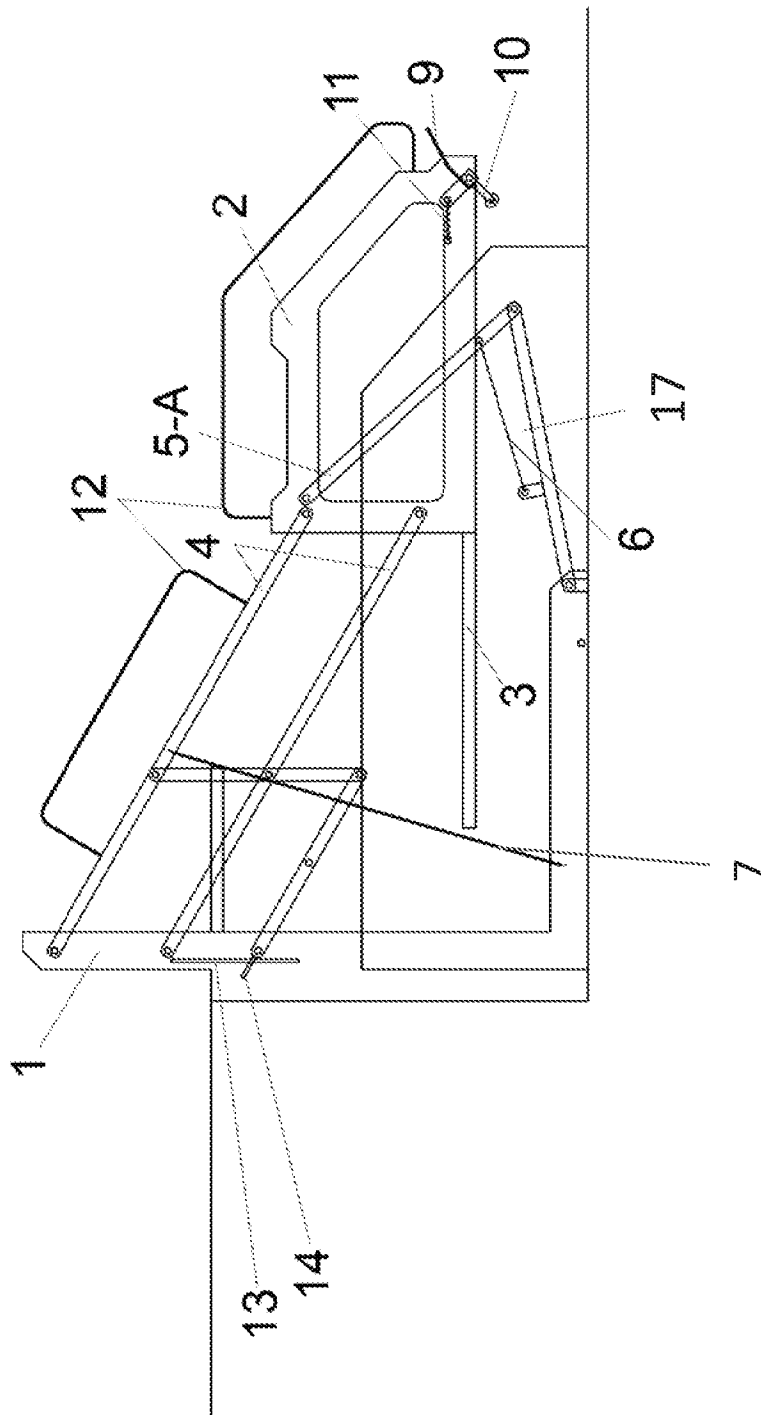

Figure - 12

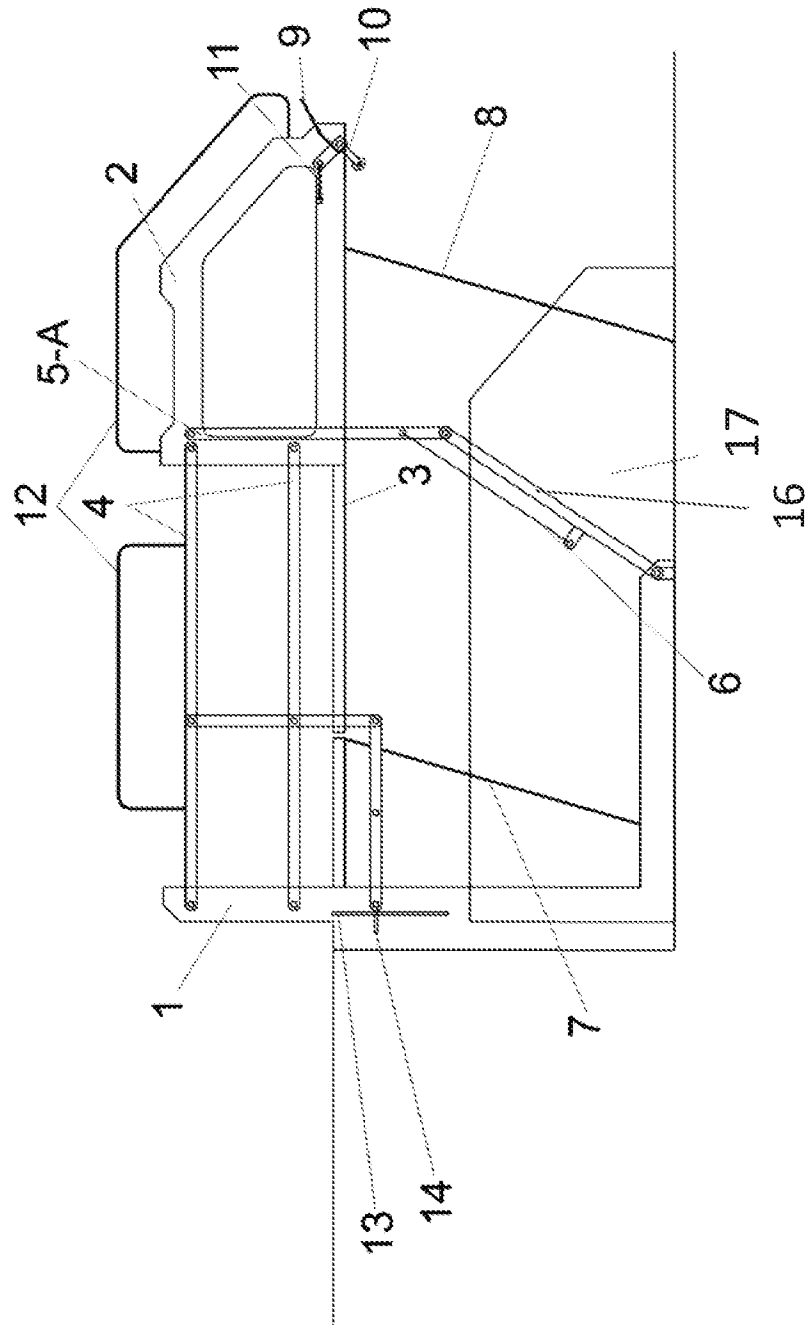

Figure - 13

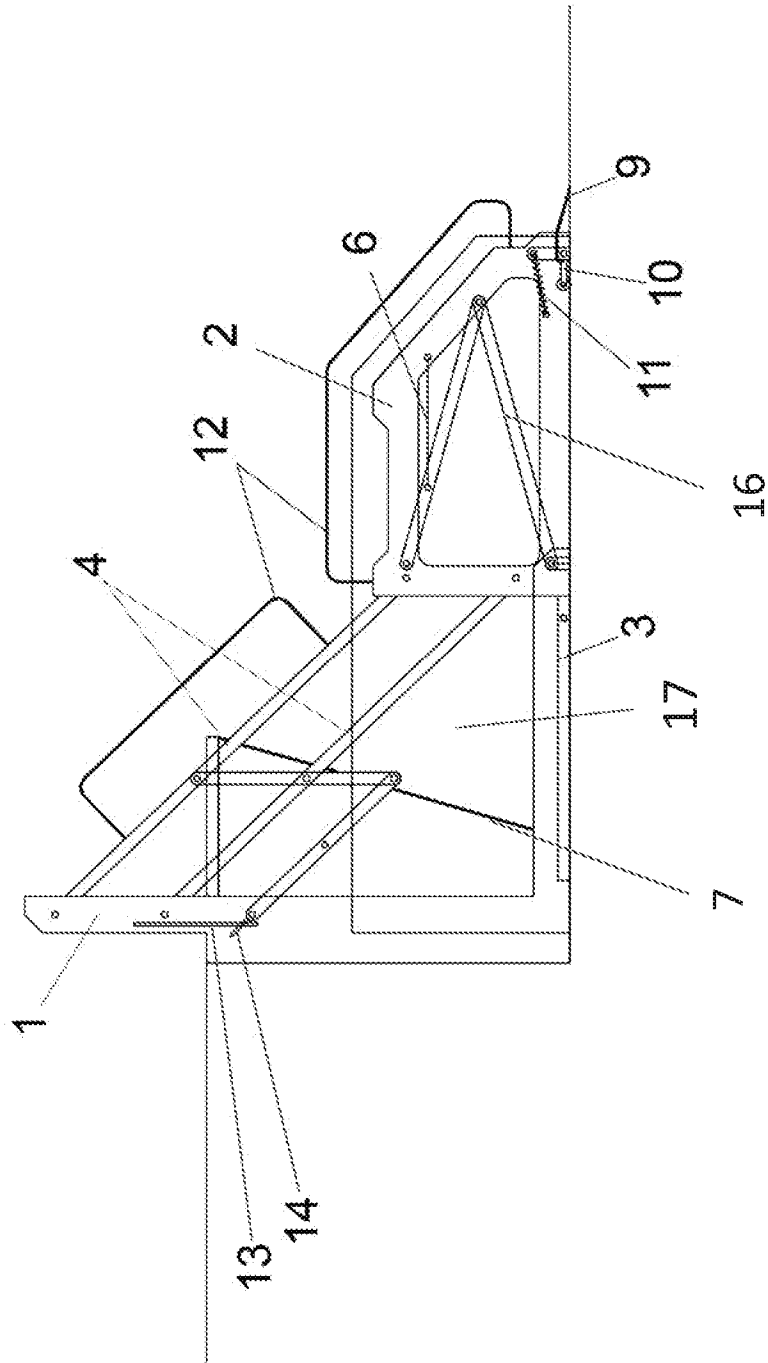

Figure - 14

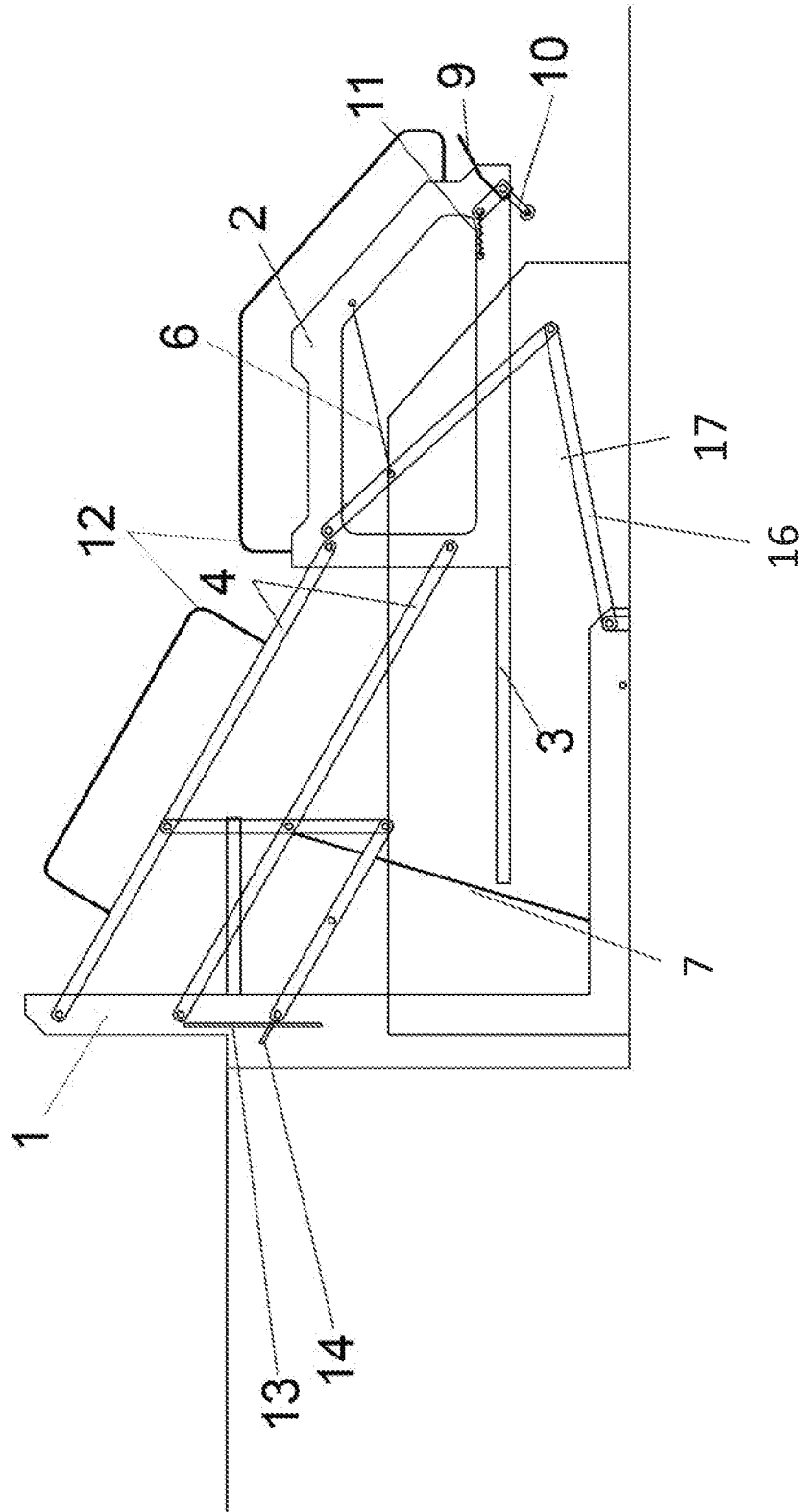

Figure - 15

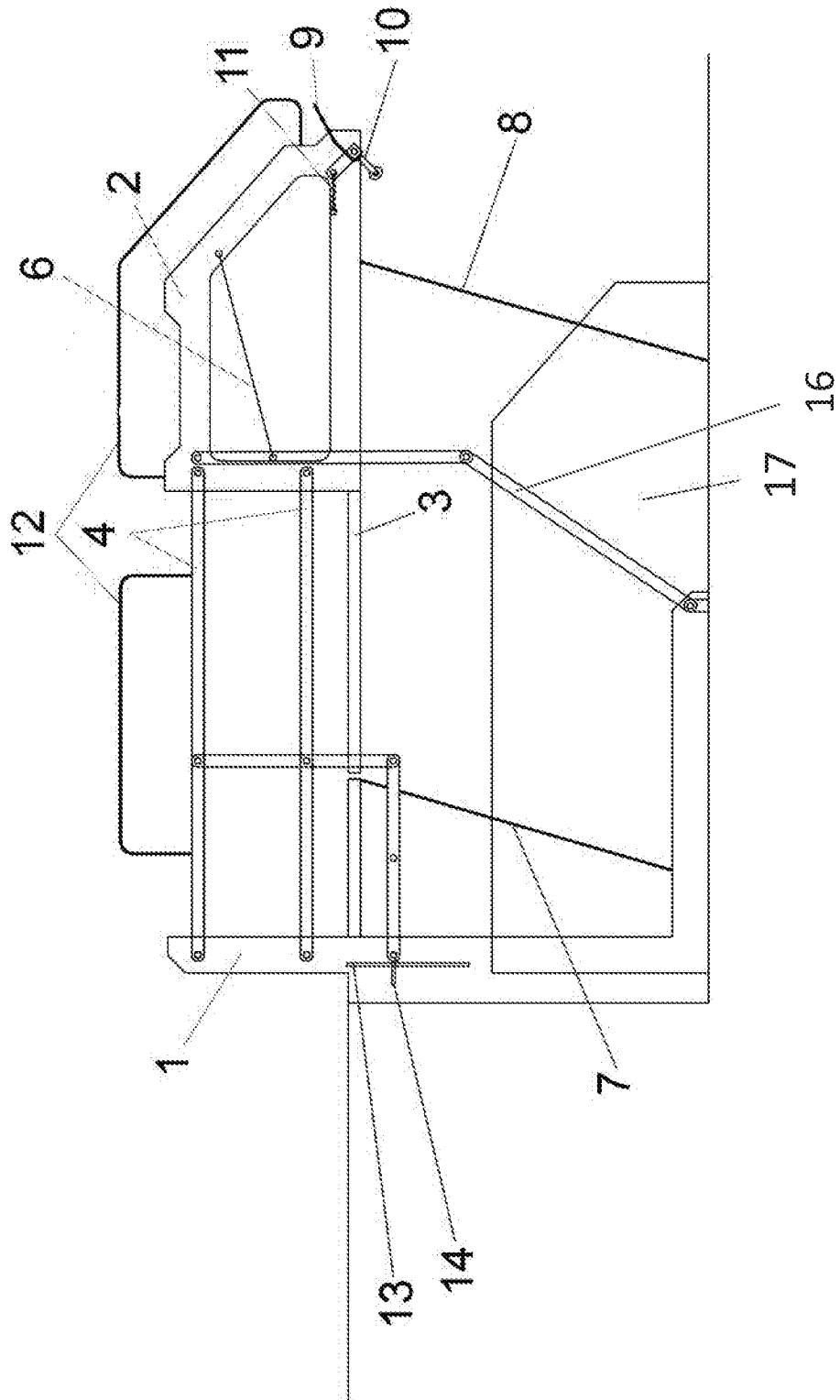

Figure - 16