

M. COVEL.
SAW SHARPENING MACHINE.

No. 523,883.

Patented July 31, 1894.

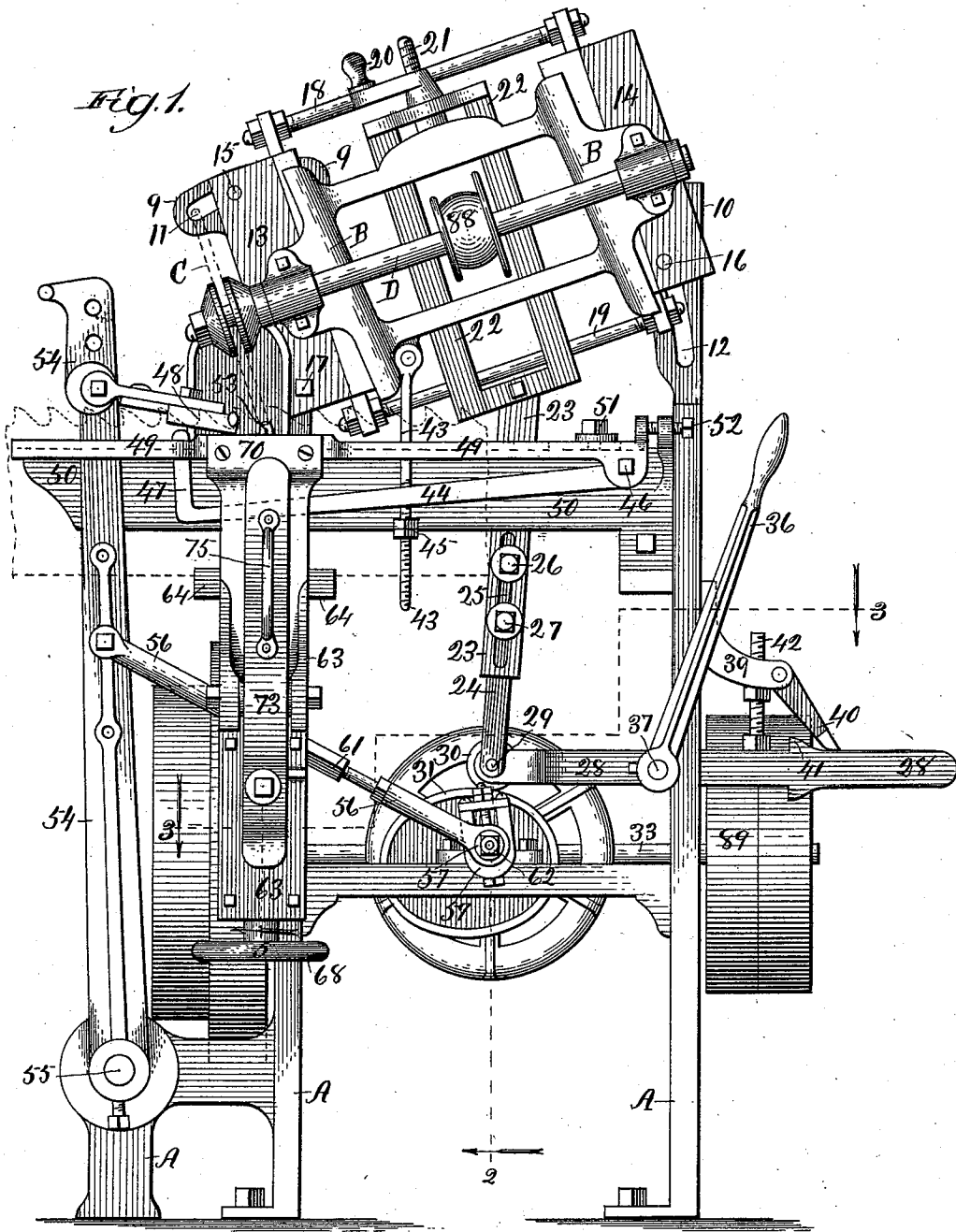

Witnesses:
Charles C. Dayford,
Clifford H. White.

Inventor:
Milo Covell,
 By *J. B. Coupland & Co.*
Attys

M. COVEL.
SAW SHARPENING MACHINE.

No. 523,883.

Patented July 31, 1894.

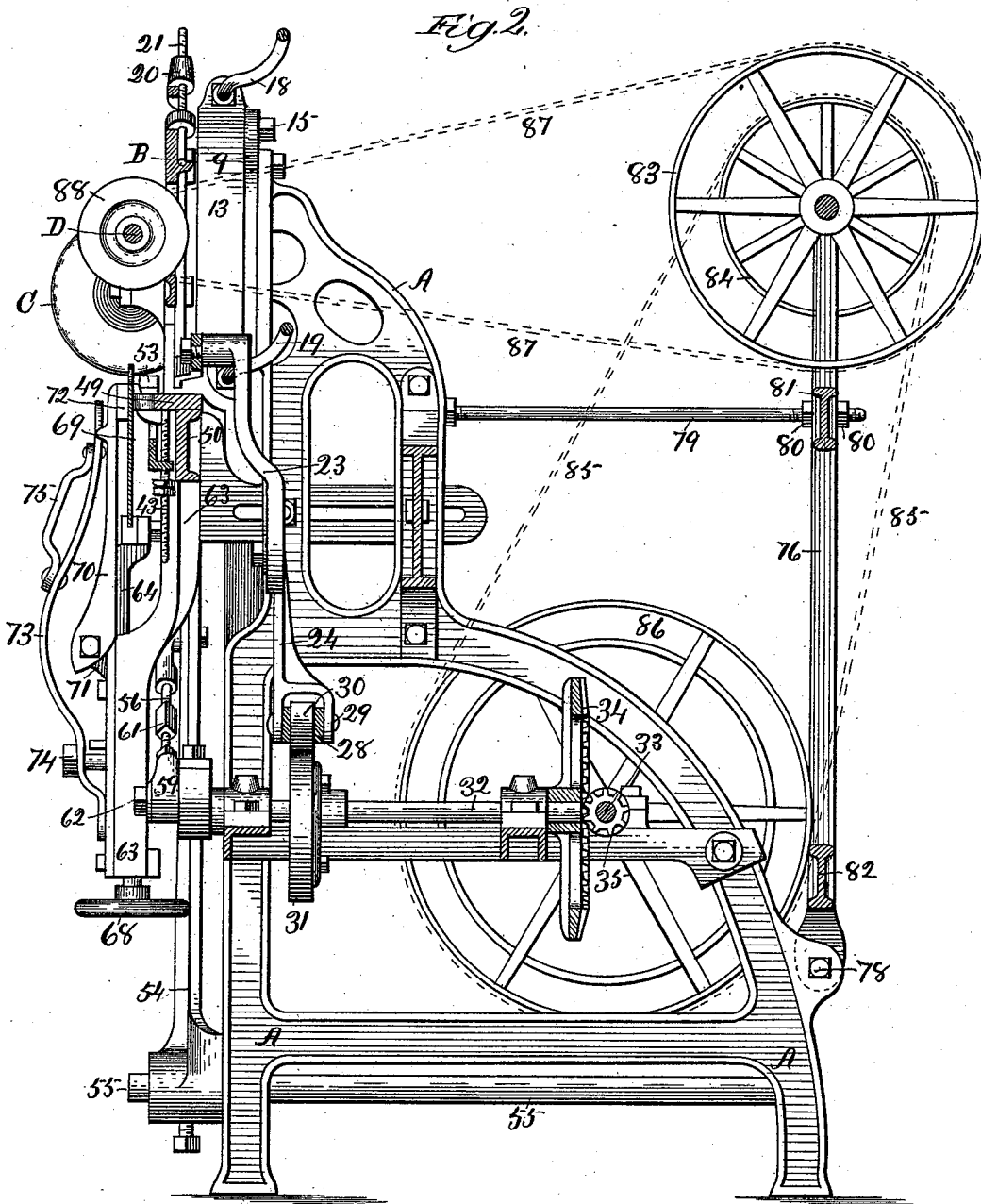

Witnesses:
Carl Coupland
Clifford H. White

Inventor:
Milo Covel
 By *S. B. Coupland & Co.*
Attys.

M. COVEL.
SAW SHARPENING MACHINE.

No. 523,883.

Patented July 31, 1894.

Fig. 4.

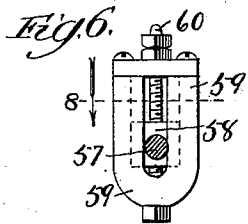
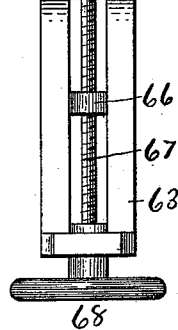
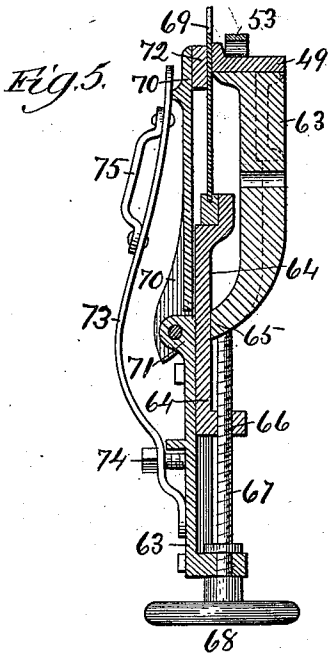
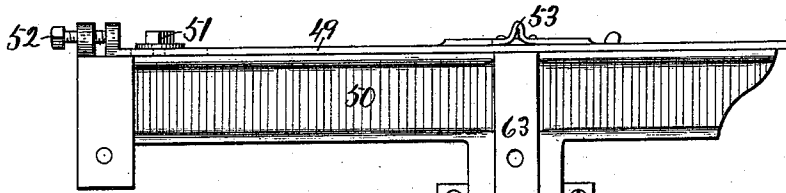

Fig. 7.

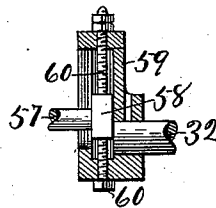
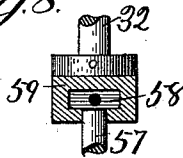

Fig. 8.



Witnesses:

*Carl S. Gaylord,
Clifford A. White.*

Inventor:

*Milo Covell,
By G. B. Coupland & Co.
Attorneys*

UNITED STATES PATENT OFFICE.

MILO COVEL, OF CHICAGO, ILLINOIS.

SAW-SHARPENING MACHINE.

SPECIFICATION forming part of Letters Patent No. 523,883, dated July 31, 1894.

Application filed December 31, 1891. Serial No. 416,678. (No model.)

To all whom it may concern:

Be it known that I, MILO COVEL, a citizen of the United States, residing at Chicago, in the county of Cook and State of Illinois, have
5 invented certain new and useful Improvements in Saw-Sharpener Machines, of which the following is a full, clear, and exact description, that will enable others to make and use the same, reference being had to the accompanying drawings, forming a part of this
10 specification, in which—

Figure 1 is a front elevation of a machine embodying my improved features; Fig. 2 a
15 vertical transverse section on line 2, Fig. 1 looking in the direction indicated by the arrow; Fig. 3 a horizontal section on the angular line 3, Fig. 1, looking downwardly as indicated; Fig. 4 a broken-away detail of part
20 of the mechanism forming the rest and stop for supporting the saw, looking outwardly. Fig. 5 is a vertical section on line 5, Fig. 1, of the rest, stop and clamping-mechanism for holding and properly adjusting the saw, with
25 reference to the sharpening wheel; Fig. 6 a vertical section on line 6, Fig. 3; Fig. 7 a sectional detail relating to the part shown in Fig. 6; and Fig. 8 a horizontal section on line 8, Fig. 6.

This invention relates to improvements in
30 that class of machines employed in automatically sharpening saws, and consists of certain novel features in the construction, arrangement, and operation of the several parts, as will be hereinafter set forth.

Referring to the drawings, A represents the
35 several parts of the supporting frame-work, B the gate attachment, and C the emery or sharpening-wheel mounted on the arbor D, journaled in said gate. The emery-wheel is
40 shown in Fig. 2, and its relative position indicated by dotted lines in Fig. 1.

The emery-wheel gate and supporting parts
45 are so constructed and arranged as to provide for a convenient adjustment so that the gate may be set at any desired angle in accordance with the particular shape or form of
50 tooth to be produced,

Two brackets, 9 and 10, are rigidly secured
50 on top of the frame; and are provided, respectively, with the curved slots, 11 and 12, as

shown in Fig. 1. The inclined guides, 13 and
14, are adjustably attached to said brackets by clamping-bolts, 15 and 16, inserted
55 through the curved slots, 11 and 12, and the pivot-bolt, 17, passing through the lower end of guide 13. This arrangement permits of
60 the inclined position of the gate being changed so as to bring the emery-wheel in contact with the saw-teeth at the desired angle. The inclined guides are connected at their upper
65 and lower ends, respectively, by the adjustable screw-rods 18 and 19. These rods are bent backwardly along their middle part (Fig. 2.) to clear the gate parts, the hand-crank 20
and screw 21 for raising and lowering the
70 emery-wheel gate by hand.

The rectangular frame 22 is rigidly secured
75 to the cross-bars of the gate, and, being of same width, more equally balances and insures a free movement of the gate. The upper end of bar 23 is connected to the lower
80 end of frame 22. The lower part of this bar (Figs. 1 and 2) overlaps the corresponding upper part of the companion bar 24 and is
85 provided with the elongated slot 25, through which clamping-bolts, 26 and 27 are inserted, adjustably securing said bars together so that
90 the same may be lengthened or shortened, as the travel of the emery-wheel-gate requires.

The lower end of bar 24 is bifurcated (Figs. 80
2 and 3.) and embraces the corresponding bifurcated end of the horizontal lever 28, which ends are connected together by the pivot-pin
85 29. The friction roller, 30, is also mounted on this pivot pin and journaled between the ends of lever 28. This roller lies in the pathway of, and has frictional contact with, the
90 periphery of cam-wheel 31 mounted on counter-shaft 32. Motion is transmitted to this shaft from the machine driving-shaft 33
95 through the medium of gear-wheel 34 and pinion 35, as shown in Figs. 2 and 3. By this arrangement an automatic movement is imparted to the emery-wheel-gate. The gate
100 may also be raised up to throw the emery-wheel out of contact with the saw, by means of hand-lever 36, rigidly mounted on the outer end of shaft 37, the inner end of which is
fixed in lever 28, and provided with a bearing in box 38, secured to the frame.

A bracket 39 (Fig. 1.) is secured to the frame and has pawl 40 pivoted in the extended end thereof, which is adapted to engage with stop-shoulder 41, on lever 28, and lock the emery-wheel-gate in its highest position when thrown up by hand.

An adjusting screw-bolt, 42, is threaded in bracket 39, the lower end having contact with the upper side of lever 28. This provides means to gage the depth of the cut, that is the downward movement of the emery-wheel into the throat of the saw-teeth. By turning down on the screw and thereby depressing that end of the lever 28, the friction-roller, journaled in the opposite end of said lever, is raised so as not to have contact with the lowest part of the rolling-cam. When the adjusting-screw is turned up out of contact with its lever, the contact of the cam and roller is continuous. The upper end of rod 43 is pivoted to a part of the gate and extends down through a part of angular lever 44. (Figs. 1 and 2.) and is threaded on its lower part to receive the set-nuts 45.

The horizontal end of lever 44 is supported by pivot-bolt 46. The opposite upturned end 47 being adapted to loosely engage with the under side of feed-finger 48, and lift the same up out of engagement with the saw-teeth when the gate is raised up to a stationary position by hand.

The set-nuts, 45, will be so adjusted on rod 43 as to not come in contact with, and raise, lever 44 when the machine is working automatically.

A plate, 49, rests on top of cross-bar 50 and is adjustably secured thereto by bolt 51 passing through an elongated slot (indicated by a dotted line) in said plate. The plate 49 has an endwise adjustment by means of set-screw 52 (Fig. 1.) so as to bring the integral stop 53 into proper position with reference to the feed-finger and limit the forward movement of the same. The feed-finger is pivoted to the upper end of rocking feed-arm, 54, the lower end of which is mounted on one end of rock-shaft 55, journaled in the lower part of the frame.

One end of connecting-rod 56 is attached to the feed-arm, and the other end mounted on bearing-pin 57 (Figs. 1, 3, 6, 7 and 8) fixed in the bearing-nut 58 adjustably seated in the rotating bearing-box 59, mounted on the outer end of counter or cam-shaft 32. Bearing-nut 58 is fixed on the adjusting-screw 60 so that the same may be moved in or out with reference to the center of axis, for the purpose of regulating the throw of the feed-arm in accordance with the distance between the teeth of different saws.

Connecting-rod 56 is in two parts and joined by the threaded sleeve, 61, providing for the adjustment of the same in connection with the adjustable bearing last described, so that the throw of the feed-arm may be regulated to a nicety. The end of connecting-rod 56 is

retained in position with reference to its bearing-pin by the screw-bolt, 62, inserted in the end of said pin.

A clamping-device for holding the saw in position during the process of sharpening will be next described.

The bracket part, 63, of the clamp is rigidly secured to the front side (Figs. 1 and 2.) of the machine. The lower bifurcated or slotted part of slide 64 (Figs. 1 and 5.) extends down on the respective sides of the curved central part, 65, of bracket 63, and has the lug 66 formed thereon, with a threaded aperture through which passes the adjusting hand-screw 67. The lower end of this screw has a threaded engagement in the corresponding part of bracket 63 and is rotated by hand-wheel 68. The head of slide 64 (Fig. 5.) is grooved to receive the back of the saw 69; the relative position of the same being also indicated by dotted lines in Fig. 1.

Clamping-plate 70 is pivoted at its lower end to the lug-part 71 of bracket 63, and has a block, 72, secured to the inside upper end which bears against the saw-blade. A spring, 73, is secured at its lower end to bracket 63 by pivot-bolt 74; the upper end of this spring bearing against the upper end of plate 70 to retain the same in a clamping position. By grasping handle-part 75 of the spring the same may be moved sidewise out of contact with plate 70, when the upper end of the latter can be drawn back, by reason of its pivotal or hinged connection, to conveniently permit of the insertion or removal of the saw.

Two vertical bars 76 and 77 (Figs. 2 and 3.) are pivoted at their lower ends, as at 78, to the rear part of the main frame. The upper part of these bars is connected with the frame by means of two rods 79, having adjusting nuts 80, so that the upper ends of these bars may be moved toward or away from the machine and locked in the position to which they have been moved. The vertical bars are connected by cross-bars 81 and 82 and form an auxiliary frame for the support of the band-pulleys 83 and 84 journaled therein.

The belt 85 (the position of the different belts is indicated in broken lines) runs from machine pulley 86 to pulley 84 mounted on top of the auxiliary frame; and belt 87 connects pulley 83 with pulley 88 on the emery-wheel shaft. Now by moving the top of the auxiliary frame away from the machine, both belts may be tightened at the same time and conveniently kept "taut" by means of the pivoted auxiliary frame and arrangement described. The pulley 89 belts with the motive power.

Having thus described my invention, what I claim as new, and desire to secure by Letters Patent, is—

1. In a saw-sharpening-machine, the combination with the grinding-wheel-gate, of a lever 28, provided with a stop-shoulder, the adjustable connection between said gate and

lever, consisting of bars 23 and 24, brackets 39, pawl 40, pivoted thereto and adapted to engage with the shoulder in said lever, and an adjusting-screw-bolt 42, substantially as set forth.

2. In a saw-sharpening machine, the combination of the sharpening-wheel-gate, rod 43, pivoted at one end to said gate, angular lever 44, the lower part of said rod extending down through said lever, and the set-nuts engaging with the threaded end of said rod, and the feed-finger, whereby the latter is lifted up out

of engagement with the saw-teeth when the gate is raised by hand, substantially as set forth.

3. In a saw-sharpening machine, the combination of bracket 63, slide 64, provided with lug 66, the adjusting hand-screw, 67, clamping-plate 70, and spring 73, provided with a handle attachment, substantially as set forth.

MILO COVEL.

Witnesses:

L. M. FREEMAN,
L. B. COUPLAND.