

(12) **United States Patent**  
**Huang et al.**

(10) **Patent No.:** **US 10,991,828 B2**  
(45) **Date of Patent:** **Apr. 27, 2021**

(54) **SEMICONDUCTOR STRUCTURE AND METHOD OF FORMING THE SAME**

(71) Applicant: **NANYA TECHNOLOGY CORPORATION**, New Taipei (TW)

(72) Inventors: **Sheng-Fu Huang**, New Taipei (TW);  
**Chung-Hsun Huang**, Taoyuan (TW)

(73) Assignee: **NANYA TECHNOLOGY CORPORATION**, New Taipei (TW)

(\* ) Notice: Subject to any disclaimer, the term of this patent is extended or adjusted under 35 U.S.C. 154(b) by 0 days.

(21) Appl. No.: **16/358,706**

(22) Filed: **Mar. 20, 2019**

(65) **Prior Publication Data**

US 2020/0303559 A1 Sep. 24, 2020

(51) **Int. Cl.**

- H01L 29/66** (2006.01)
- H01L 29/786** (2006.01)
- H01L 29/49** (2006.01)
- H01L 21/033** (2006.01)
- H01L 21/311** (2006.01)
- H01L 21/285** (2006.01)
- H01L 21/02** (2006.01)
- H01L 21/768** (2006.01)

(52) **U.S. Cl.**

- CPC .... **H01L 29/78609** (2013.01); **H01L 21/0217** (2013.01); **H01L 21/0228** (2013.01); **H01L 21/02164** (2013.01); **H01L 21/0337** (2013.01); **H01L 21/28518** (2013.01); **H01L 21/31111** (2013.01); **H01L 21/76897** (2013.01); **H01L 29/4908** (2013.01); **H01L 29/4933** (2013.01); **H01L 29/665** (2013.01); **H01L 29/66742** (2013.01)

(58) **Field of Classification Search**

CPC ..... H01L 21/823418; H01L 29/665  
USPC ..... 257/384  
See application file for complete search history.

(56) **References Cited**

U.S. PATENT DOCUMENTS

- 7,709,903 B2 \* 5/2010 Wang ..... H01L 21/28518 257/382
- 9,922,978 B2 \* 3/2018 Ching ..... H01L 29/6653
- 10,134,731 B2 \* 11/2018 Lii ..... H01L 21/28518
- 2016/0093524 A1 3/2016 Izumi et al.

FOREIGN PATENT DOCUMENTS

- |    |           |         |
|----|-----------|---------|
| CN | 108122907 | 6/2018  |
| TW | 201709517 | 3/2017  |
| TW | 201839906 | 11/2018 |
| TW | 201839983 | 11/2018 |

OTHER PUBLICATIONS

“Office Action of Taiwan Counterpart Application,” dated Sep. 17, 2019, p. 1-p. 12.

\* cited by examiner

*Primary Examiner* — Mark V Prenty

(74) *Attorney, Agent, or Firm* — JCIPRNET

(57) **ABSTRACT**

A semiconductor structure and a method of forming the same are provided. In the semiconductor structure, contact spacers are formed at least on sidewalls of contact trenches in the substrate, so that the distance between the gate and the silicide layers disposed only on the bottom surfaces, rather than on the sidewalls and the bottom surfaces, of the contact trenches can be increased, and thus the current leakage induced by gate can be decreased.

**4 Claims, 3 Drawing Sheets**

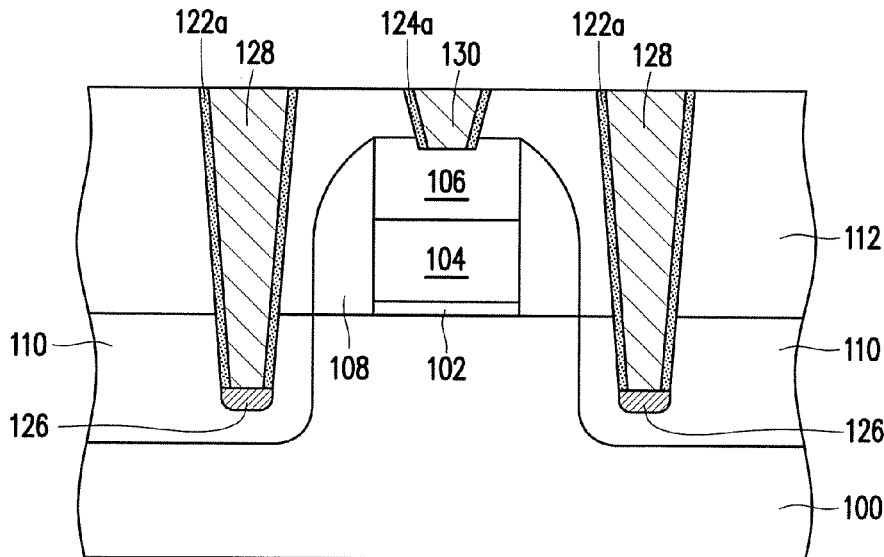

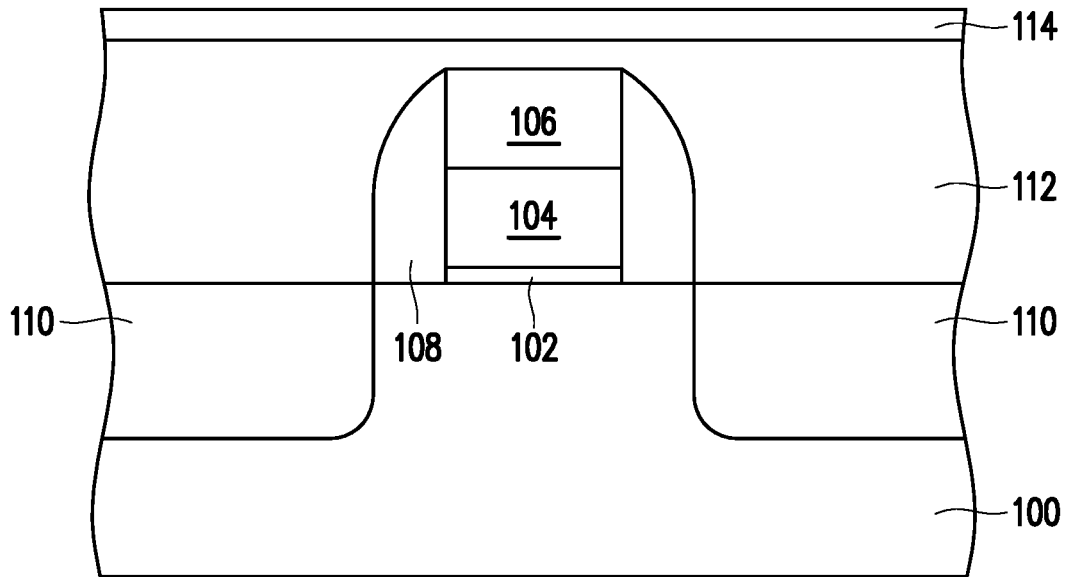

FIG. 1A

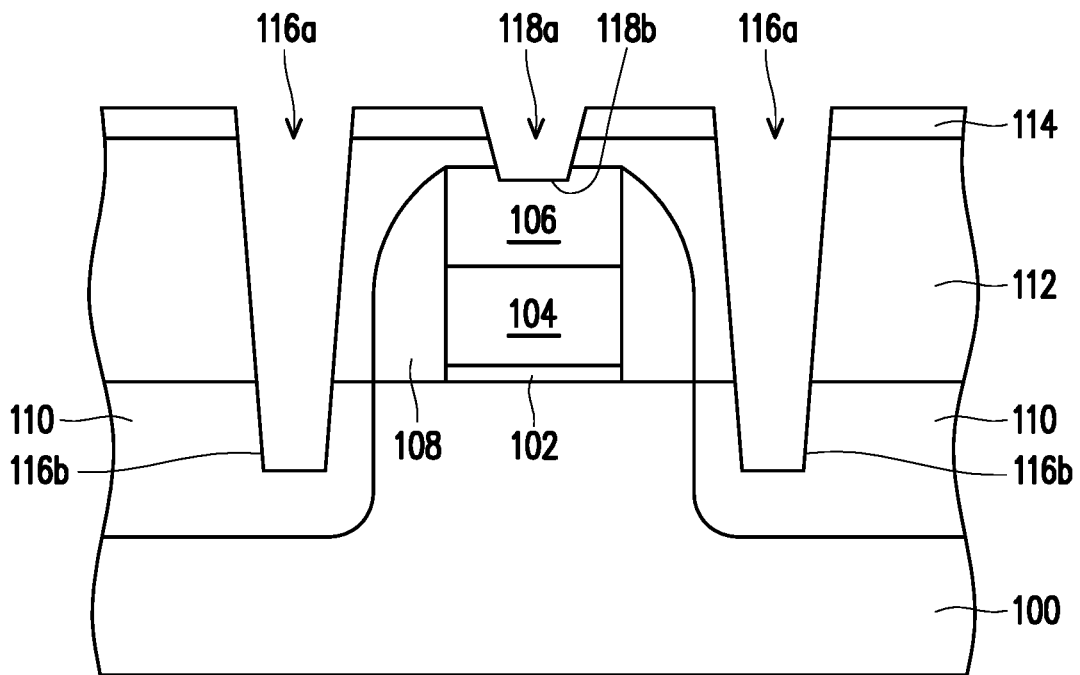

FIG. 1B

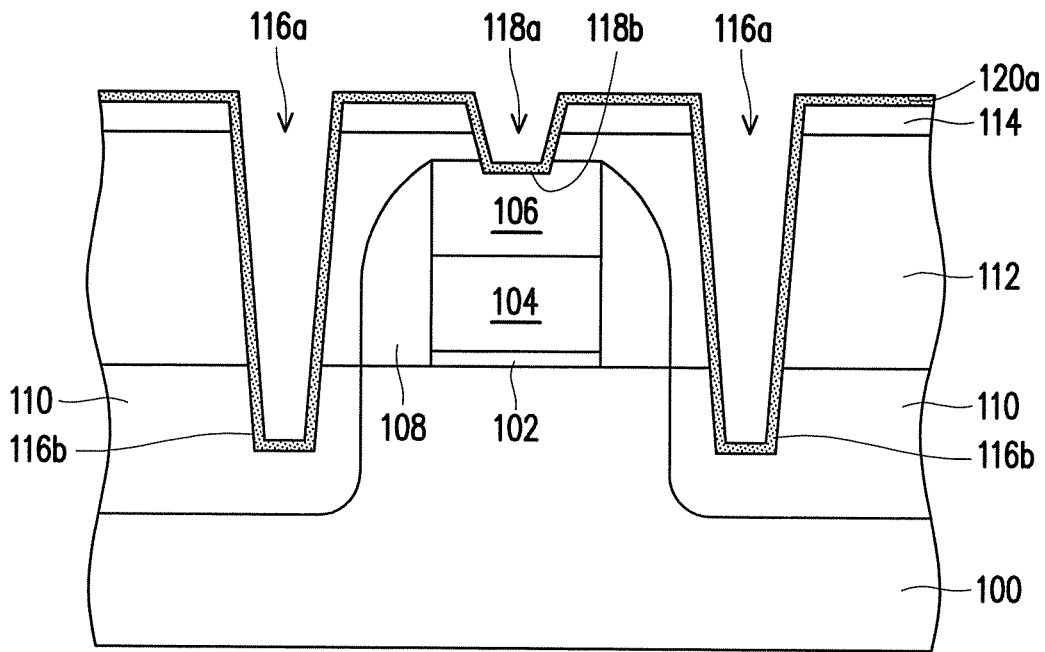

FIG. 2A

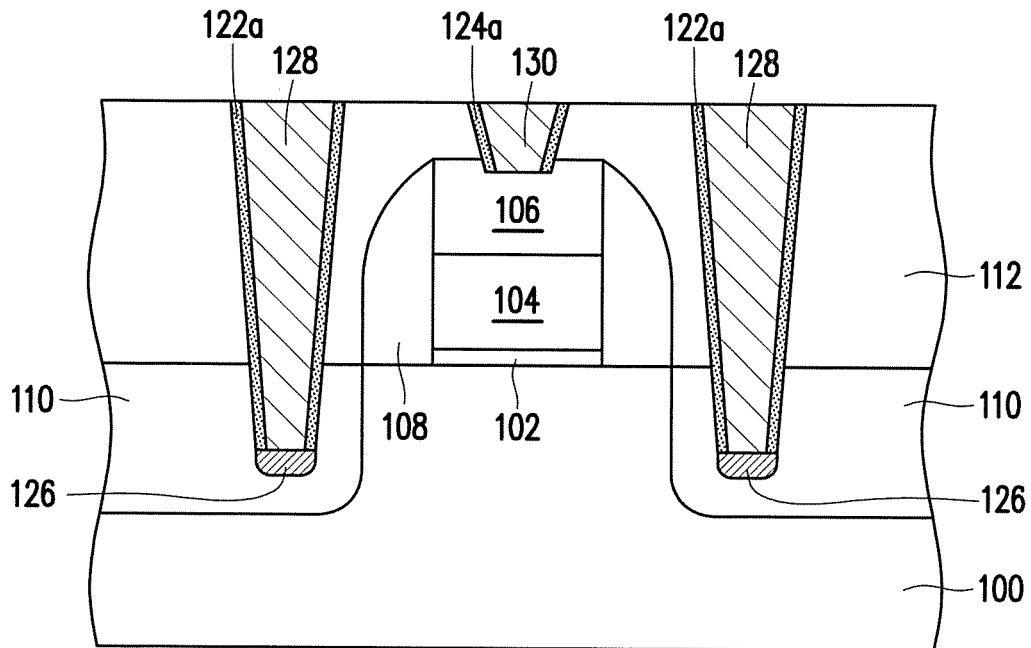

FIG. 2B

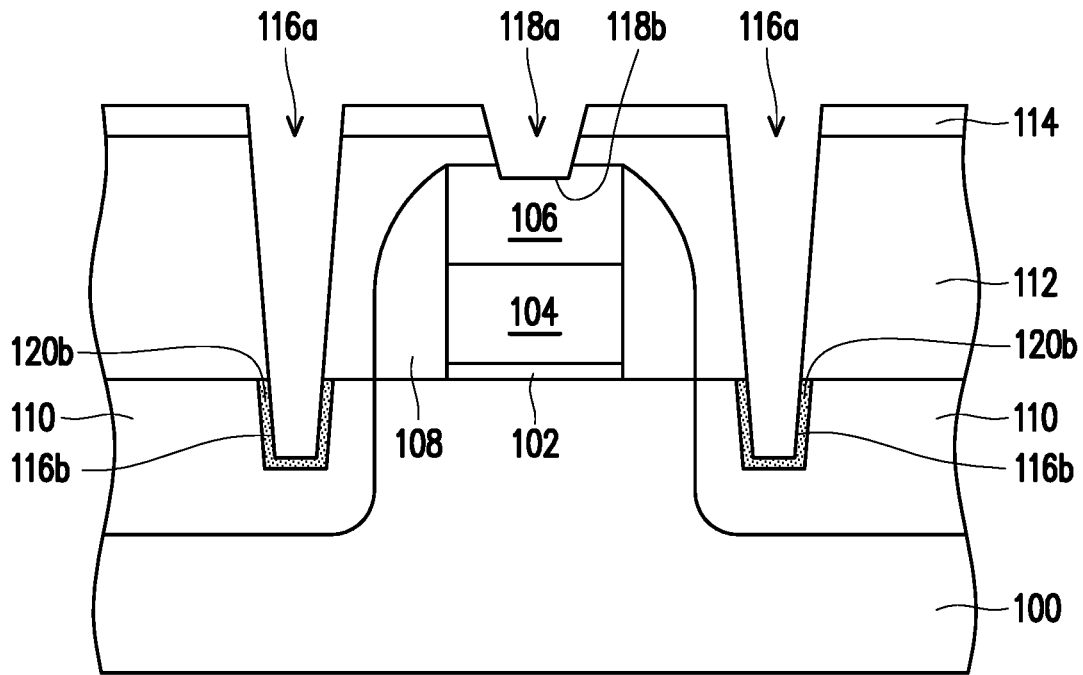

FIG. 3A

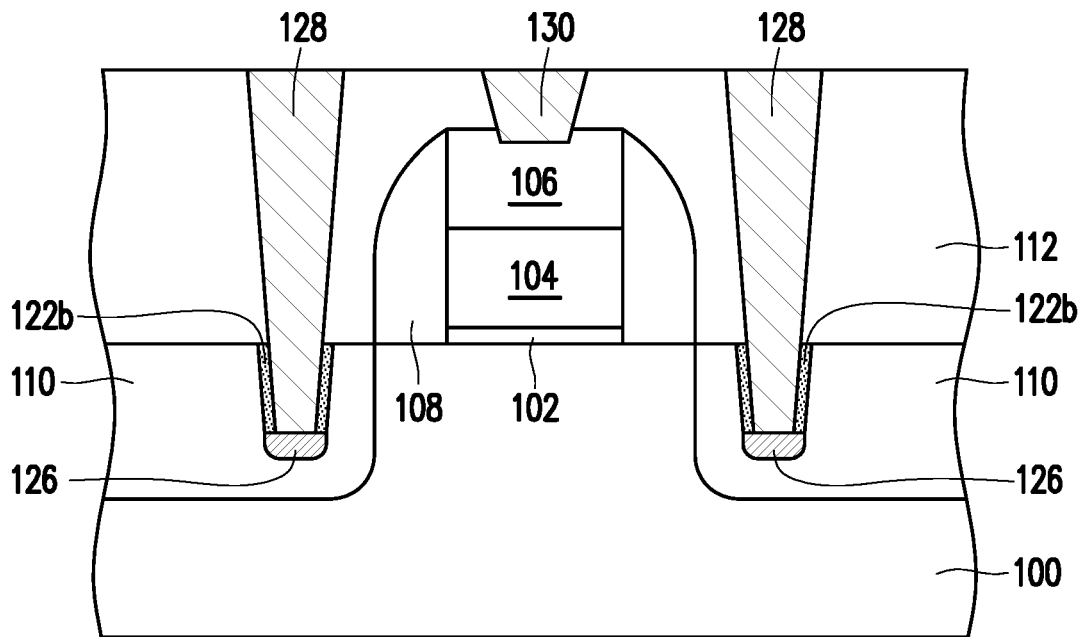

FIG. 3B

## SEMICONDUCTOR STRUCTURE AND METHOD OF FORMING THE SAME

### BACKGROUND

#### 1. Field of this Invention

This disclosure is related to a semiconductor structure, especially related to a semiconductor structure for preventing current leakage induced by gate.

#### 2. Description of Related Art

After forming contact openings on source and drain of a MOS FET, silicide layers are often formed on the surface of the source and drain to decrease the contact resistance. However, as the critical dimension is decreased as the integration is increased, drain leakage current is also increased to adversely affect the performance of the MOS-FET.

### SUMMARY

According to one aspect of this invention, a semiconductor structure is provided to decrease the current leakage induced by gate.

The semiconductor structure above comprises a gate structure disposed on a substrate; a source and a drain disposed in the substrate on two sides of the gate structure; a dielectric layer disposed on the substrate and the gate structure; two contact openings disposed in the dielectric layer to respectively expose the source and the drain; two contact trenches disposed in the source and drain and under the two contact openings, respectively; two contact spacers respectively covering sidewalls of the contact trenches for avoiding current leakage induced by gate; two silicide layers disposed under the bottom surface of the contact trenches; and two contact plugs filled in the contact trenches and the contact openings.

In some embodiments of this invention, the contact spacers further cover sidewalls of the contact openings.

In some other embodiments of this invention, the material of the contact spacers comprises silicon oxide or silicon nitride

In yet some other embodiments of this invention, the material of the silicide layers comprises  $\text{TiSi}_2$ ,  $\text{NiSi}_2$ , or  $\text{CoSi}_2$ .

According to another aspect of this invention, a method of forming the semiconductor structure is also provided. First, a gate structure is formed on a substrate, and a source and a drain are then formed in the substrate on two sides of the gate structure. A dielectric layer is formed on the substrate and the gate structure. Next, two contact openings are formed in the dielectric layer to respectively expose the source and the drain. Subsequently, two contact trenches are formed in the source and drain and under the two contact openings, respectively. Two contact spacers are formed to respectively cover sidewalls of the contact trenches for avoiding current leakage induced by gate. Two silicide layers are formed under the bottom surface of the contact trenches. Then, two contact plugs are formed to fill the contact trenches and the contact openings.

In some embodiments of this invention, the contact spacers may be formed by forming contact dielectric layers respectively on surfaces of the contact trenches by thermal oxidation or thermal nitridation; and then anisotropically

etching the contact dielectric layers to form the contact spacers on the sidewalls of the contact trenches and expose the substrate.

In some other embodiments of this invention, the contact spacers may be formed by forming a contact dielectric layer conformally covering exposed surfaces of the dielectric layer, the contact openings and the contact trenches; and then anisotropically etching the contact dielectric layer to form the contact spacers on the sidewalls of the contact openings and the contact trenches and expose the substrate.

In yet some other embodiments of this invention, a hard mask layer is formed on the dielectric layer between the dielectric layer is formed and the contact openings are formed. The hard mask layer is used as an etching mask when the dielectric layer is etched to form the contact openings. The hard mask layer is removed between the two contact spacers are formed and the silicide layers are formed.

In light of the foregoing, since the contact spacers are formed at least on sidewalls of the contact trenches in the substrate, so that the distance between the gate and the silicide layers below the bottom surfaces, rather than on the sidewalls and the bottom surfaces, of the contact trenches can be increased, and thus the current leakage induced by gate can be decreased.

### BRIEF DESCRIPTION OF THE DRAWINGS

FIGS. 1A-1B and 2A-2B are schematic cross-sectional views showing a process of forming a semiconductor structure according to an embodiment of this invention.

FIGS. 1A-1B and 3A-3B are schematic cross-sectional views showing a process of forming a semiconductor structure according to another embodiment of this invention.

### DESCRIPTION OF THE EMBODIMENTS

FIGS. 1A-1B and 2A-2B are schematic cross-sectional views showing a process of forming a semiconductor structure according to an embodiment of this invention. FIGS. 1A-1B and 3A-3B are schematic cross-sectional views showing a process of forming a semiconductor structure according to another embodiment of this invention.

In FIG. 1A, a gate dielectric layer **102**, a gate layer **104** and a gate mask layer **106** are sequentially formed on a substrate **100**. Next, the gate dielectric layer **102**, the gate layer **104**, and the gate mask layer **106** are patterned by a patterning process, such as photolithography and etching, to form a gate structure having the gate dielectric layer **102**, the gate layer **104** and the gate mask layer **106**. In this step, the gate mask layer **106** is used as an etching mask when the gate layer **104** and the gate dielectric layer **102** are etched. The gate dielectric layer **102** may be a silicon oxide layer, or a high-k dielectric layer such as a hafnium oxide layer or a zirconium oxide layer. The gate layer **104** is a conductive layer, such as a doped polysilicon layer or a metal layer (e.g. a tungsten layer). The gate mask layer **106** may be a silicon oxide layer.

Next, an insulating layer, such as a silicon oxide layer, is conformally formed on the substrate **100** and the gate structure, and then anisotropically etched to form gate spacers **108** on sidewalls of the gate structure. Subsequently, source/drain **110** are formed in the substrate **100** on two sides of the gate structure by ion implantation. A dielectric layer **112** and a hard mask layer **114** are sequentially formed on the substrate **100**. The dielectric layer **112** may be a silicon oxide layer or a low-k dielectric layer, such as a

fluorine-doped silicon oxide layer, a carbon-doped oxide layer (CDO), a porous silicon oxide layer, or a spin-on glass layer. The hard mask layer 114 may be a silicon nitride layer.

In FIG. 1B, the hard mask layer 114 and the dielectric layer 112 are patterned, such as photolithography and etching, to form contact openings 116a and a gate opening 118a in the dielectric layer 112. Then, the exposed substrate 100 under the contact openings 116a and the exposed gate mask layer 106 under the gate opening 118a are subsequently over etched to form contact trenches 116b in the source/drain 110 in the substrate 100 and a gate trench 118b in the gate mask layer 106. In this etching process, the hard mask layer 114 is used as an etching mask.

Next, there are two choices may be made to complete the rest of the process of forming the semiconductor structure. The first choice is depicted in FIGS. 2A and 2B, the second choice is depicted in FIGS. 3A and 3B.

In FIG. 2A of the first choice, a contact dielectric layer 120a is conformally formed on the exposed surfaces of the substrate 100, the dielectric layer 112, and the hard mask layer 114. The contact dielectric layer 120a may be a silicon oxide layer or a silicon nitride layer, and the method of forming the contact dielectric layer may be chemical vapor deposition (CVD).

In FIG. 2B of the first choice, the contact dielectric layer 120a is then anisotropically etched to respectively form contact spacers 122a on the sidewalls of the contact openings 116a and the contact trenches 116b to expose the substrate 100, as well as gate contact spacers 124a on sidewalls of the gate opening 118a and the gate trench 118b to expose the gate mask layer 106. Please note that the exposed sidewall of the contact trenches 116b are covered by the contact spacers 122a, only the bottom surface of the contact trenches 116b are not covered by the contact spacers 122a to expose the substrate 100.

Then, metal silicide layers 126 are formed on the exposed substrate 100 by a salicidation process, which comprises depositing a metal layer and then performing a thermal process to allow the metal layer react with the exposed substrate 100 to form the silicide layers 126. The metal silicide layers may be  $\text{TiSi}_2$ ,  $\text{NiSi}_2$ , or  $\text{CoSi}_2$ , for example.

In this step, since contact spacers 122a cover the sidewalls of the contact trenches 116b, the metal silicide layers 126 may be formed only on the bottom surface of the contact trenches 116b, and no metal silicide can be formed on sidewalls of the contact trenches 116b. Therefore, the distance between the conductive metal silicide layers 126 and the gate layer 104 can be kept at a distance far enough to avoid current leakage induced by the gate layer 104.

Next, the hard mask layer 114 is removed, and a metal layer is deposited to fill the contact openings 116a, the contact trenches 116b, the gate opening 118a and the gate trench 118b, and then etched back. Thus, contact plugs 128 are formed in the contact openings 116a and the contact trenches 116b, and a gate plug 130 is formed in the gate opening 118a and the gate trench 118b. The metal layer may be a tungsten layer.

In FIG. 3A of the second choice, a contact dielectric layer 120b is formed only on the exposed surfaces of the contact trenches 116b in the substrate 100. The contact dielectric layer 120b may be a silicon oxide layer or a silicon nitride layer, and may be formed by a thermal oxidation process or a thermal nitridation process.

In FIG. 3B of the second choice, the contact dielectric layer 120b is then anisotropically etched to form contact spacers 122b on the sidewalls of the contact trenches 116b

in the substrate 100 to expose the substrate 100. Please note that the exposed sidewall of the contact trenches 116b are covered by the contact spacers 122b, only the bottom surface of the contact trenches 116b are not covered by the contact spacers 122b to expose the substrate 100.

Then, metal silicide layers 126 are formed on the exposed substrate 100 by a salicidation process, which comprises depositing a metal layer and then performing a thermal process to allow the metal layer react with the exposed substrate 100 to form the silicide layers 126. The metal silicide layers may be  $\text{TiSi}_2$ ,  $\text{NiSi}_2$ , or  $\text{CoSi}_2$ , for example.

In this step, since contact spacers 122b cover the sidewalls of the contact trenches 116b, the metal silicide layers 126 may be formed only on the bottom surface of the contact trenches 116b, and no metal silicide can be formed on sidewalls of the contact trenches 116b. Therefore, the distance between the conductive metal silicide layers 126 and the gate layer 104 can be kept at a distance far enough to avoid current leakage induced by the gate layer 104.

In light of the foregoing, since the contact spacers are formed at least on sidewalls of the contact trenches in the substrate, so that the distance between the gate and the silicide layers below the bottom surfaces, rather than on the sidewalls and the bottom surfaces, of the contact trenches can be increased, and thus the current leakage induced by gate can be decreased.

Although implementations of the present invention have been described above in detail in combination with the attached drawings, the above-described implementations could not be interpreted as limitation to the present invention. Various modifications can be made by those skilled in the art within their knowledge without departing from the spirit and scope of the present invention.

What is claimed is:

1. A semiconductor structure for avoiding current leakage, comprising:

- a gate structure disposed on a substrate;
- a source and a drain disposed in the substrate on two sides of the gate structure;
- a dielectric layer disposed on the substrate and the gate structure;

two contact openings disposed in the dielectric layer to respectively expose the source and the drain;

two contact trenches disposed in the source and drain and under the two contact openings, respectively;

two contact spacers respectively covering sidewalls of the contact trenches for avoiding current leakage induced by the gate structure, wherein a material of the contact spacers comprises silicon oxide or silicon nitride;

two silicide layers disposed under the bottom surface of the contact trenches; and

two contact plugs filled in the contact trenches and the contact openings,

wherein the gate structure comprises:

- a gate dielectric layer on the substrate;
- a gate layer on the gate dielectric layer; and
- a gate mask layer on the gate layer.

2. The semiconductor structure of claim 1, wherein the contact spacers further cover sidewalls of the contact openings.

3. The semiconductor structure of claim 1, wherein a material of the silicide layers comprises  $\text{TiSi}_2$ ,  $\text{NiSi}_2$ , or  $\text{CoSi}_2$ .

4. The semiconductor structure of claim 1, further comprising gate spacers on the sidewall of the gate structure.