

(No Model.)

2 Sheets—Sheet 1.

W. Y. OBER & F. M. STEVENS.

SEAM FINISHING MACHINE.

No. 296,869.

Patented Apr. 15, 1884.

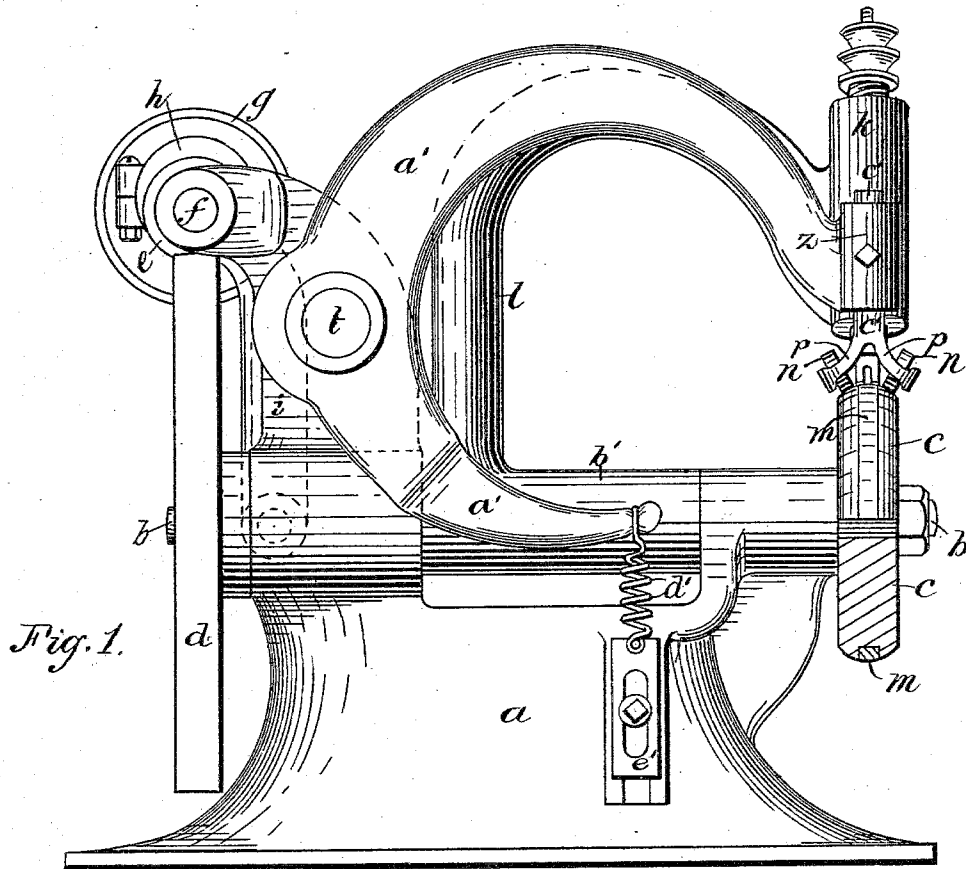

Fig. 1.

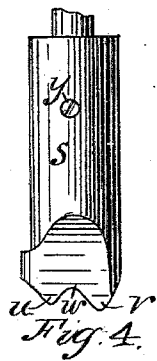

Fig. 4.

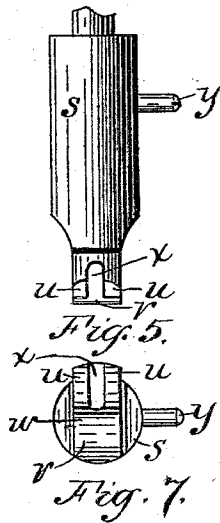

Fig. 5.

Fig. 7.

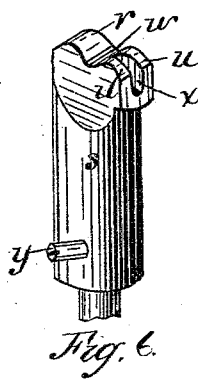

Fig. 6.

Witnesses:

Chas. S. Gooding.
Eugene Humphrey

Inventors:

William Y. Ober,
Frank M. Stevens,
Jes. Porter & Hutchinson
attys.

(No Model.)

2 Sheets—Sheet 2.

W. Y. OBER & F. M. STEVENS.

SEAM FINISHING MACHINE.

No. 296,869.

Patented Apr. 15, 1884.

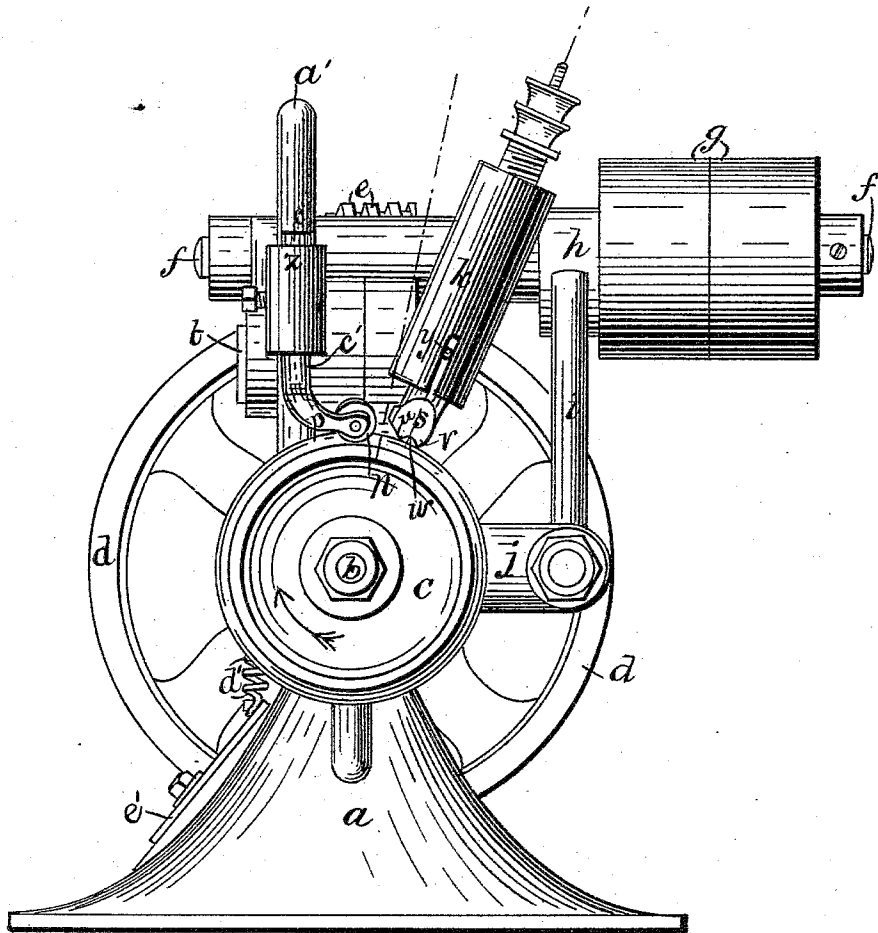
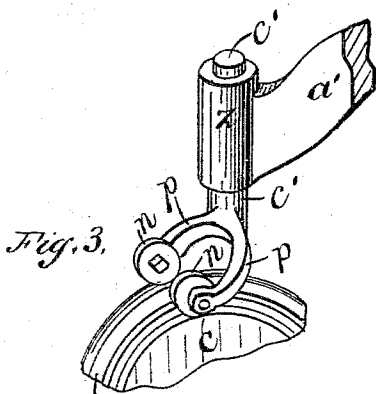

Fig. 2.



Witnesses:
 Chas. S. Gooding
 Eugene Humphrey

Inventors.
 William Y. Ober & Frank M. Stevens
 per Porter & Hutchinson
 attys

UNITED STATES PATENT OFFICE.

WILLIAM Y. OBER, OF LYNN, AND FRANK M. STEVENS, OF BOSTON, MASS.

SEAM-FINISHING MACHINE.

SPECIFICATION forming part of Letters Patent No. 296,869, dated April 15, 1884.

Application filed July 2, 1883. (No model.)

To all whom it may concern:

Be it known that we, WILLIAM Y. OBER, of Lynn, in the county of Essex, and FRANK M. STEVENS, of Boston, in the county of Suffolk, and State of Massachusetts, have invented a new and useful Improvement in Seam-Finishing Machines, which will, in connection with the accompanying drawings, be hereinafter fully described, and specifically defined in the appended claims.

This invention relates to a machine that is adapted to rubbing down and smoothing seams in leather and analogous materials; and the present invention is an improvement upon the machine described and shown in said Ober's application No. 95,531, filed May 19, 1883, for Letters Patent of the United States for "Improvements in Seam-Finishing Machines," and is shown in the present drawings in connection with a machine mainly like that shown in the drawings filed in said Ober's application; and the present invention consists in the construction and combination of divers devices embodied therein, as hereinafter more particularly and fully set forth and claimed.

In the accompanying drawings, Figure 1 is a side elevation of the machine with our improvements thereto applied. Fig. 2 is a front elevation of the machine, taken as viewed from the right in Fig. 1. Fig. 3 is a detached perspective view, showing the upper portion of the supporting-wheel, the pressure-rolls resting thereon, and the means by which said rolls are mounted in position. Fig. 4 is a detached side elevation of the rubber, taken as viewed in Fig. 2. Fig. 5 is an edge elevation of the rubber, taken as viewed from the left in Figs. 2, 4. Fig. 6 is an inverted perspective view of the rubber. Fig. 7 is an inverted plan view of the rubber.

In said views, *a* represents the frame or body of the machine, in which is journaled the lower arbor, *b*, on which are mounted the supporting-wheel *c* at the front and the tangent-wheel *d* at the rear. An upper arbor, *f*, carries fast and loose pulleys *g*, through which it is rotated by a belt, and also carries an endless screw, *e*, which engages wheel *d*, and thereby, through arbor *b*, rotates supporting-wheel *c*. A head, *k*, is carried by arm *l*, which is formed upon or rigidly secured to sleeve *b'*, which is mounted

on arbor *b*, as shown in Fig. 1. Said sleeve is slightly rotated on the arbor by means of an eccentric secured on shaft *f* and acting in strap *h*, and through rod *i* and arm *j*, which latter is formed upon and extends from said sleeve *b'*, and is pivotally connected with said rod *i*, whereby said head *k* is vibrated or reciprocated a limited distance along the periphery of wheel *c*, as indicated by a dotted line in Fig. 2, which represents the axis of head *k* when in its most advanced position to the left, all said devices and their movements being fully shown and described in Ober's said former application, and which are referred to here merely for the purpose of preliminary illustration. In head *k* is seated the rubber *s*, which bears by a yielding spring-pressure upon the periphery of wheel *c*, or the seam when interposed between the wheel and rubber, as is fully described and shown in Ober's said application. The lower end or operative face of said rubber we form with two rounded ridges, *uv*, with a depression, *w*, between them, and we form a central groove, *x*, in ridge *u*, as shown in Figs. 5, 6, 7, and so as to be transverse to the line of said ridge, and in the direction of the plane of wheel *c* when coacting therewith. A curved arm, *a'*, is pivoted in body *a* upon bolt *t*, and is controlled by spring *d'*, which is attached to said arm and to adjustable plate *e'*, as shown in Fig. 1. Said arm at its upper and outer end is formed with a head, *z*, in which is seated and secured by a set-screw, as shown, the stem *e'*, by the forks *pp* of which are pivotally supported the small pressure-rolls *n n*, which, as shown in Figs. 1, 2, 3, are arranged to bear upon the oblique faces of the periphery of wheel *c*, their axes being arranged slightly to the left, Fig. 2, of the extreme forward movement of rubber *s*, in order that the seamed leather, when carried forward by said wheel in the direction indicated by the arrow thereon, shall be engaged by said rolls before rubber *s* begins to act upon it. Said supporting-wheel, we form with a central groove, which we fill with leather or other slightly-yielding material, (shown at *m*,) which will insure the desired frictional contact with the seamed leather that is carried forward by the wheel when the machine is in use.

The practical operation of our machine is as

follows: The seamed leather is placed upon wheel *c*, at the left of wheels *n*, as viewed in Fig. 2, with the line of the seam coincident with band *m* in wheel *c*, and is moved forward and entered between said wheel and rolls, by which it is automatically carried past rubber *s*, the seam moving in groove *x* therein, thus serving to hold it centrally upon the wheel, and as the seam is carried forward, the ridge *v*, formed across the face of the rubber, flattens and smooths it to the level of the adjacent surface. When the seamed leather encounters the rolls *n*, as just described, it is, by their pressure caused by spring *d'*, curved transversely to the line of the seam, and so as to conform to the transverse configuration of the periphery of wheel *c*, thereby facilitating the action of rubber *s* upon the seam. A small stud, *y*, extending from rubber *s*, enters an open slot in head *k* and secures the rubber from rotation in the usual manner.

We claim as our invention—

1. In a seam-finishing machine, the supporting-wheel *c*, grooved and provided with a band, *m*, of leather or other suitable and slightly-yielding material, and also having the peripheral face of the wheel, on either side of said band, formed oblique to the plane of the wheel, whereby the cross-section of the face constitutes an unbroken curved line, substantially as specified.

2. The supporting-wheel *c*, formed with a central recess and inserted band, *m*, and with its periphery upon each side of said band oblique to its plane, substantially as specified. 35

3. In combination with supporting-wheel *c* and rubber *s*, the small rolls *n n*, arranged to allow the seam to pass between them and to co-operate with said wheel and rubber, substantially as specified. 40

4. The combination, with the supporting-wheel *c*, formed with a central bearing, *m*, and an oblique peripheral face on each side thereof, of rolls *n n*, arranged with their axes and peripheries coincident with the oblique faces of said wheel, substantially as specified. 45

5. The rubber *s*, formed with a groove, *x*, extending partially but not wholly across its face, substantially as specified.

6. The rubbers *s*, formed with the facial ridges *u v*, and the depression *w* between the same, substantially as specified. 50

7. The rubber *s*, formed with the facial ridge *u*, having the slot *x* therein, and the ridge *v*, extending across the face of the rubber, substantially as specified. 55

WILLIAM Y. OBER.
FRANK M. STEVENS.

Witnesses:

EUGENE HUMPHREY,
T. W. PORTER.