

No. 696,296.

Patented Mar. 25, 1902.

J. ANGELL.

HEATER AND SEPARATOR FOR STEAM GENERATING PLANTS.

(Application filed July 27, 1901.)

(No Model.)

2 Sheets—Sheet 1.

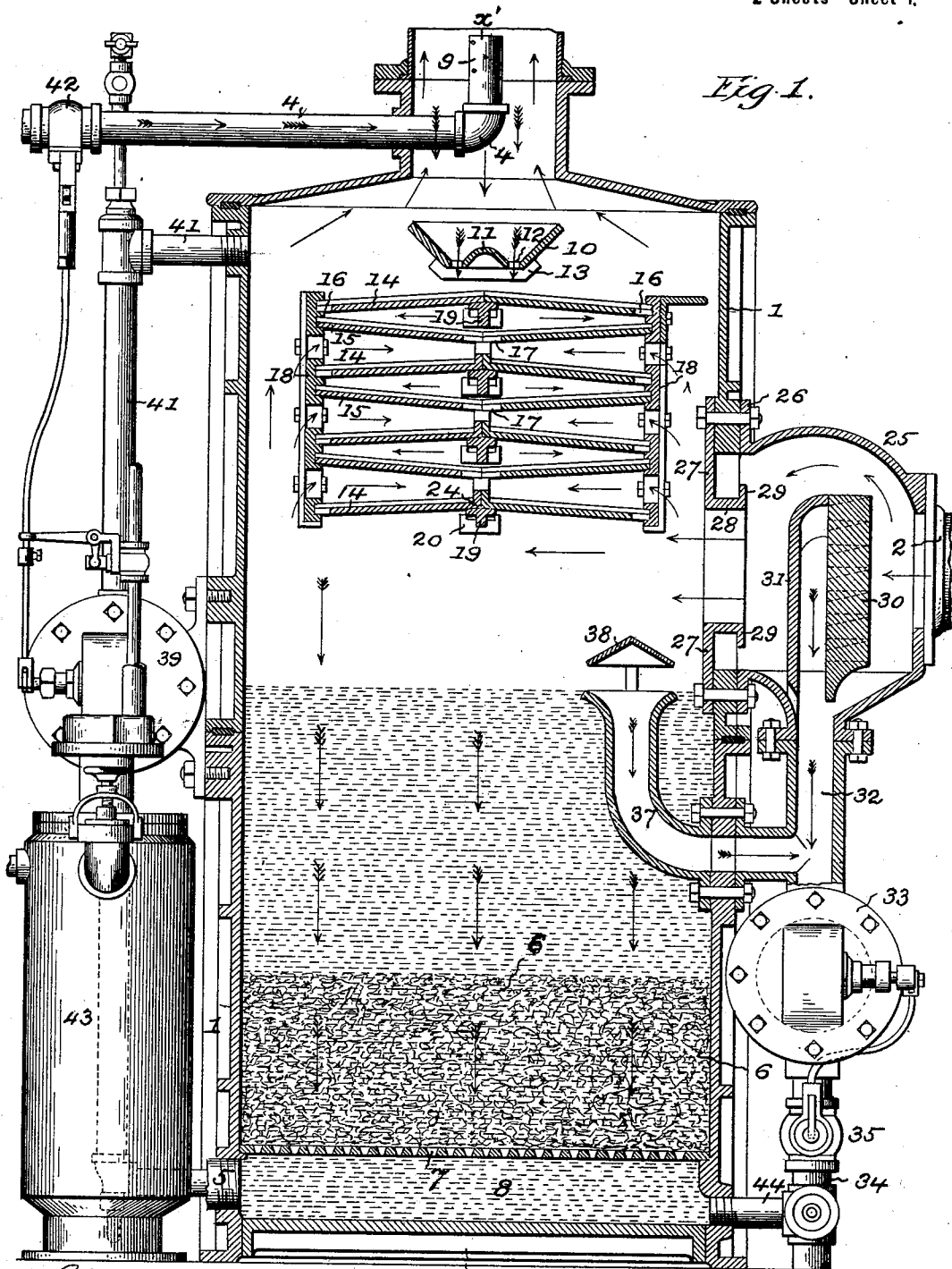

Fig. 1.

Attest:
M. H. Holmes
Henry A. Nott

Inventor:
John Angell,
by Robert Burns Atty.

J. ANGELL.

HEATER AND SEPARATOR FOR STEAM GENERATING PLANTS.

(Application filed July 27, 1901.)

(No Model.)

2 Sheets—Sheet 2.

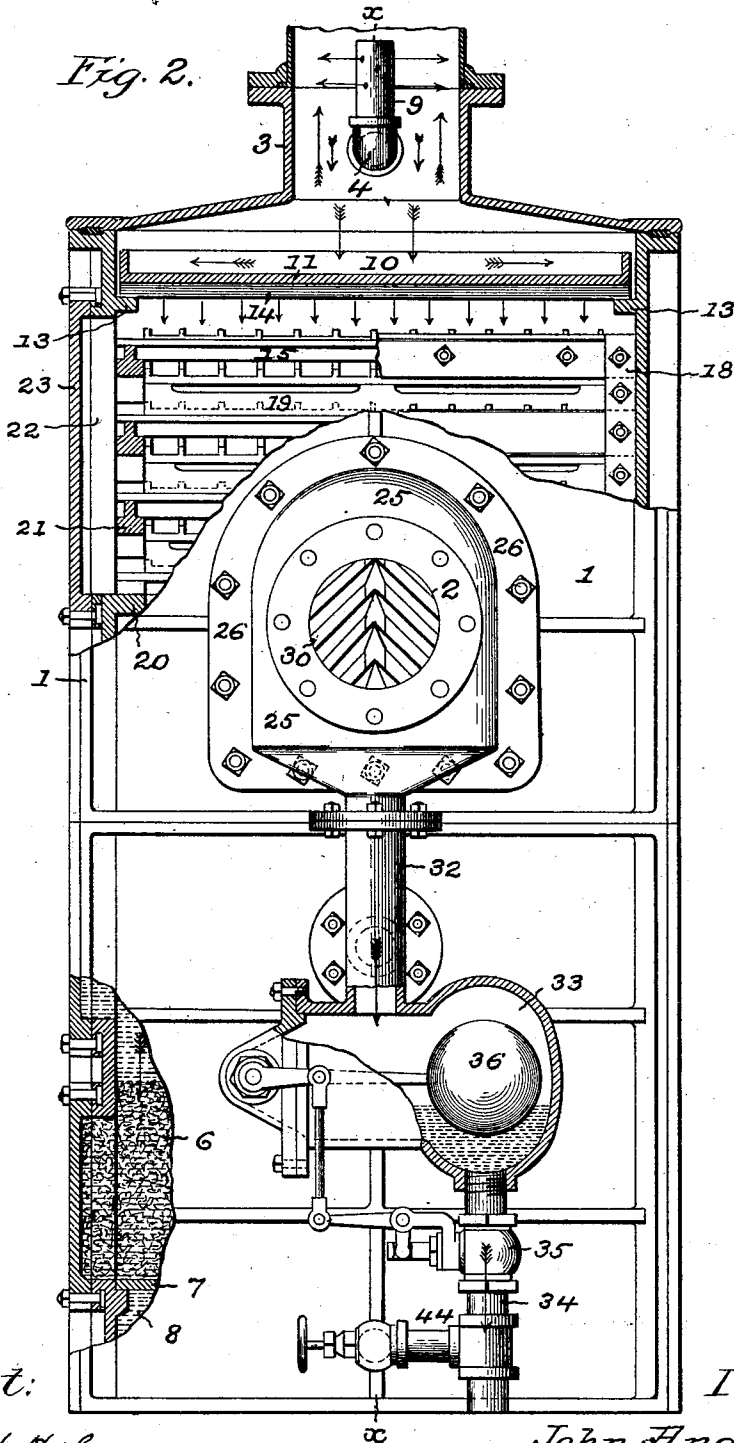

Attest:

M. H. Holmes
Henry A. Vott

Inventor:

John Angell,
by Robert C. Swins
Atty.

UNITED STATES PATENT OFFICE.

JOHN ANGELL, OF ST. LOUIS, MISSOURI.

HEATER AND SEPARATOR FOR STEAM-GENERATING PLANTS.

SPECIFICATION forming part of Letters Patent No. 696,296, dated March 25, 1902.

Original application filed April 27, 1901, Serial No. 57,685. Divided and this application filed July 27, 1901. Serial No. 69,882. (No model.)

To all whom it may concern:

Be it known that I, JOHN ANGELL, a citizen of the United States, and a resident of the city of St. Louis, in the State of Missouri, have invented certain new and useful Improvements in Heaters and Separators for Steam-Generating Plants; and I do hereby declare the following to be a full, clear, and exact description of the same, reference being had to the accompanying drawings, forming a part of this specification.

The present invention relates to that type of apparatus employed in steam-engineering plants in which the feed-water is caused to trickle down a series of shelves or trays arranged within a closed casing and in its downward passage is exposed to the exhaust-steam from the engine to effect an economical heating of such feed-water, and more especially to that particular type of such apparatus in which means is provided to separate the entrainment-grease and other impurities from the incoming exhaust-steam and the scum and lighter impurities from the heated feed-water.

The objects of the present improvement are to provide a simple and efficient apparatus in which the grease and other impurities carried by the exhaust-steam into the apparatus by entrainment are collected and separately removed in an automatic manner and with which the scum and other light impurities of the heated feed-water are in like manner skimmed off and removed, all as will hereinafter more fully appear, and be more particularly pointed out in the claims. I attain such objects by the construction and arrangement of parts illustrated in the accompanying drawings, in which—

Figure 1 is a longitudinal vertical section at line xx , Fig. 2, of a feed-water heating and purifying apparatus embodying the present improvements; Fig. 2, an end elevation of the same with parts in section at line $x'x'$, Fig. 1.

Similar numerals of reference indicate like parts in both views.

Referring to the drawings, 1 represents a vertically-arranged closed casing or housing of any usual and approved construction and which in the present improvement constitutes

a heating-chamber for effecting the desired heating of the feed-water by the exhaust-steam from the engine and a receiving-chamber for the heated feed-water, and which receiving-chamber is in turn provided with an intermediate filter-bed through which the feed-water passes to have its suspended impurities removed before being fed to the steam-generator. The casing 1 is also provided with the usual steam-inlet neck or passage 2, steam-outlet neck or passage 3, feed-water inlet pipe or passage 4, and feed-water outlet pipe or passage 5, extending either directly to the steam-generator or to the feed-pump by which the generator is supplied.

6 is the usual filter-bed, supported on a perforated grid 7, arranged a distance above the bottom of the casing or tank 1, so as to leave a clear-water chamber 8, with which the feed-water outlet-pipe 5 is connected.

9 is an upturned and laterally-perforated extension of the feed-water inlet-pipe 4, arranged centrally in the steam outlet or exhaust neck 3 of the heater-casing and adapted to discharge the feed-water in jets and in a direction transverse of the outgoing steam and against the inner walls of such neck, so that more or less of the feed-water will trickle down said inner walls of the outlet-neck and from thence down the inner surface of the heater-casing to afford an increased and effective heating and condensing surface in the operation of the present apparatus.

10 is an elongated water-receiving trough or hopper supported centrally beneath the outlet-neck 3 by end lugs 11 on the main casing and adapted to receive the feed-water discharged from the inlet-pipe 4 as such water rains down from the outlet-neck 3. Such trough is provided with a central raised web or partition 12 and a series of perforations 13 at each side of such web, the construction being adapted to divide and distribute the water in an even manner to the series of surface-heating plates or shelves arranged beneath said trough and occupying the upper portion of the casing 1.

14 and 15 are alternating series of surface-heating shelves or plates, the one series, 14, slanting downwardly from the center, and the other series, 15, slanting downwardly

from the sides, as shown in Fig. 1. Each shelf or plate will preferably consist of two straight halves meeting at the center, as shown, and the first-mentioned series, 14, will be provided with passages 16 at their outward edges for the passage downward at such points of the feed-water onto the next adjacent shelf below, while the last-mentioned series, 15, are provided with passages 17 at their center for the passage downward at such points of the feed-water onto the next adjacent shelf below, so that such feed-water will have a circuitous or serpentine passage down along the series of shelves to have an extended and effective exposure to the exhaust-steam to attain a very efficient heating of the passing feed-water. From the lowermost shelf of the series the heated feed-water drips down into the receiving-chamber therefor in the lower part of the main casing, as illustrated in Fig. 1. The series of shelves are preferably ribbed in the direction of their slant, so as to maintain an extended separation of the feed-water flowing over the same.

18 represents skeleton end frames supporting the series of shelves 14 and 15 at their outer ends, and which skeleton frames are in turn supported on lugs attached to the inside of the main casing, as shown in Fig. 2. The skeleton formation of the frames 18 is intended to permit of the free and effective entrance or access of the exhaust-steam to the series of shelves and to the thin stratum of feed-water flowing upon the same.

19 represents intermediate supporting-bars for the support of the central or middle portion of the series of shelves 14, such supporting-bars resting at one end on lugs 20 on the main casing and at the other end upon transverse bars 21, extending across the doorway 22 of the main casing and resting upon lugs at the side of such doorway, and which doorway is normally closed by a door or cover 23. In the construction shown the series of shelves or plates 15 are supported at their central or middle portion by upwardly-extending lugs or flanges 24 of the shelves 14, that form rests for the central edges of the halves of the series of shelves 15 and permit of the free upward passage of the exhaust-steam and a contact of the same with the feed-water falling through the central openings 17 of the series of shelves 15.

No claim is herein made for the special construction of feed-water-heating apparatus so far described, as the same forms the subject-matter of my original application, Serial No. 57,685, filed April 27, 1901, and of which the present application is a division.

25 is a water or grease separator, secured at one side of the main heater-casing at a point above the normal water-level in the main heater-casing and having the usual arrangement of intercepting partitions for intercepting the water, grease, &c., of entrainment carried by the exhaust-steam. Preference is given to the particular construction of sepa-

rator shown in Fig. 1 of the drawings as best adapted to the present construction and arrangement of parts. No broad claim is, however, made in the present application to such construction of the separator, other than the special formation of the same which adapts it for use with the present improvements. Its general features of construction form the subject-matter of a companion application for Letters Patent, Serial No. 57,162, filed April 24, 1901. In the particular construction shown the separator-casing is provided at one side with a flange 26, by means of which it is bolted to the side of the main heater-casing with its outlet-opening in register with the inlet-passage into such main casing for the exhaust-steam and at the opposite side with an inlet-neck for the attachment of the exhaust-steam pipe or main, as shown in Figs. 1 and 2.

27 is an annular disk secured upon the inside of the main casing, preferably by the same bolts which secure the separator in place, and formed with a cylindrical neck 28, which in turn is provided with an annular marginal flange 29. Such parts have an axial arrangement in the main inlet-orifice to the main heater-casing, as shown, and are adapted to form a very efficient barrier to prevent the usual creeping action of the water, grease, &c., of entrainment in the direction taken by the steam and into the main heater-casing to mix with the feed-water and be returned to the steam-generator.

30 is a reticulated grid arranged in the interior of the separator-casing and in the path of the incoming exhaust-steam and adapted to divide or separate the exhaust-steam and direct the same in its divided condition against the imperforate impact-partition 31, so that the water, grease, &c., of entrainment will adhere to and be retained by the surface of such partition, while the steam is left free to continue its travel into the heater-chamber.

32 is a passage leading downward from the separator 25 and adapted to conduct the water, grease, &c., of entrainment away from the same.

33 is a receiving-chamber at the lower end of the passage 32, adapted to receive the entrainment-water, &c., and provided with a blow-off pipe or passage 34, provided in turn with an automatic blow-off valve 35, operatively connected with a float 36 in said chamber and adapted to automatically open and blow off the contents of such chamber when such contents reach a predetermined level in the chamber by the gradual accumulation of the entrainment-water, &c.

37 is a branch elbow pipe or passage extending into the interior of the main heater-casing, with the open end of its vertical portion on a level with the normal or predetermined water-level in said main casing. Such open end is preferably formed flaring or funnel-shaped to more effectively act as a skimmer for securing the surface-water and the scum

and impurities carried thereby and conduct the same down into the receiving-chamber 32, to be blown off from the same in an automatic manner along with the entrainment-water, &c.

5 38 is a cone-shaped cap located a distance above the funnel-shaped mouth of the branch passage 37 and adapted to intercept any feed-water from dropping directly into such mouth.

A predetermined water-level is automatically maintained in the main heater-casing by means of a float within a float-chamber 39, having pressure-equalizing steam and water pipe connections 40 and 41 with the heater-casing and operative connections with the valve 42 in the feed-water inlet-pipe 4, as set forth in detail in my aforesaid original application, Serial No. 57,685.

43 is a closed tank or holder for the purge or coagulant compound used in the purification of the water. The special construction and arrangement of this tank forms the subject-matter of a companion application for Letters Patent, filed of even date herewith, and consequently no detailed description will be given in the present case.

44 is a valved blow-off pipe connecting the lower end of the main heater-casing with the blow-off pipe 34 for use in cleaning out the apparatus.

30 Having thus fully described my said invention, what I claim as new, and desire to secure by Letters Patent, is—

1. The combination in a feed-water heater, of a main heater-casing, a separator for the entrainment-water or the like, comprising a housing provided with a flange at one side for attachment to the heater-casing, a reticulated grid arranged vertically within said housing transverse to the steam-inlet, a vertical impact-plate arranged back of said grid, a receiving-chamber attached to the side of the heater-casing, a tubular connection between the lower end of the separator-housing and the upper end of said receiving-chamber, a horizontal branch connection extending from such tubular connection to the heater-casing and having a receiving-mouth within the interior of such casing arranged on a level with the normal water-level in such casing, a blow-off pipe connected to the lower end of the receiving-chamber, a valve in said blow-off pipe, a float in said receiving-chamber, and operative connections between said float and said valve, substantially as described.

55 2. The combination in a feed-water heater, of a main heater-casing, a separator for the entrainment-water or the like, comprising a housing provided with a flange at one side for attachment to the heater-casing, a reticulated grid arranged vertically within said housing transverse to the steam-inlet, a vertical impact-plate arranged back of said grid, a receiving-chamber attached to the side of the heater-casing, a tubular connection between the lower end of the separator-housing and the upper end of said receiving-chamber, a horizontal branch connection extending from

such tubular connection to the heater-casing, and angular tubular connection arranged within the heater-casing with its lower end connecting with said horizontal connection and its upper end formed with a flaring mouth arranged on a level with the normal water-level of the heater-casing, a blow-off pipe connected to the lower end of the receiving-chamber, a valve in said blow-off pipe, a float in said receiving-chamber, and operative connections between said float and said valve, substantially as described.

3. The combination in a feed-water heater, of a main heater-casing, a separator for the entrainment-water or the like, comprising a housing provided with a flange at one side for attachment to the heater-casing, a reticulated grid arranged vertically within said housing transverse to the steam-inlet, a vertical impact-plate arranged back of said grid, a receiving-chamber attached to the side of the heater-casing, a tubular connection between the lower end of the separator-housing and the upper end of said receiving-chamber, a horizontal branch connection extending from such tubular connection to the heater-casing, an angular tubular connection arranged within the heater-casing with its lower end connecting with said horizontal connection and its upper end formed with a flaring mouth arranged on a level with the normal water-level of the heater-casing a cone-shaped cap arranged in separated relation above said mouth, a blow-off pipe connected to the lower end of the receiving-chamber, a valve in said blow-off pipe, a float in said receiving-chamber, and operative connections between said float and said valve, substantially as described.

4. The combination in a feed-water heater, of a main heater-casing, a separator for the entrainment-water or the like, comprising a housing provided with a flange at one side for attachment to the heater-casing, a cylindrical neck arranged axially in the outlet-orifice of the separator-housing and secured in place by an annular disk bolted to the inside of the heater-casing in opposed relation to the attaching-flange of said separator-housing, a reticulated grid arranged vertically within said housing transverse to the steam-inlet, a vertical impact-plate arranged back of said grid, a receiving-chamber attached to the side of the heater-casing, a tubular connection between the lower end of the separator-housing and the upper end of said receiving-chamber, a blow-off pipe connected to the lower end of the receiving-chamber, a valve in said blow-off pipe, a float in said receiving-chamber, and operative connections between said float and said valve, substantially as described.

5. The combination in a feed-water heater, of a main heater-casing, a separator for the entrainment-water or the like, comprising a housing provided with a flange at one side for attachment to the heater-casing, a cylindrical

neck arranged axially in the outlet-orifice of the separator-housing and provided at one end with an annular outturned rim and at the other end with an annular disk by which it is attached to the inside of the heater-casing in opposed relation to the attaching-flange of said separator-housing, a reticulated grid arranged vertically within said housing transverse to the steam-inlet, a vertical impact-plate arranged back of said grid, a receiving-chamber attached to the side of the heater-casing, a tubular connection between the lower end of the separator-housing and the

upper end of said receiving-chamber, a blow-off pipe connected to the lower end of the receiving-chamber, a valve in said blow-off pipe, a float in said receiving-chamber, and operative connections between said float and said valve, substantially as described.

In testimony whereof witness my hand, this 24th day of July, 1901, at St. Louis, Missouri.

JOHN ANGELL.

In presence of—
MORTON JOURDAN,
STEPHEN C. ROGERS.