

Dec. 6, 1927.

1,651,925

S. H. MARSH

BOTTLE WASHING MACHINE

Filed Sept. 13, 1924

2 Sheets-Sheet 1

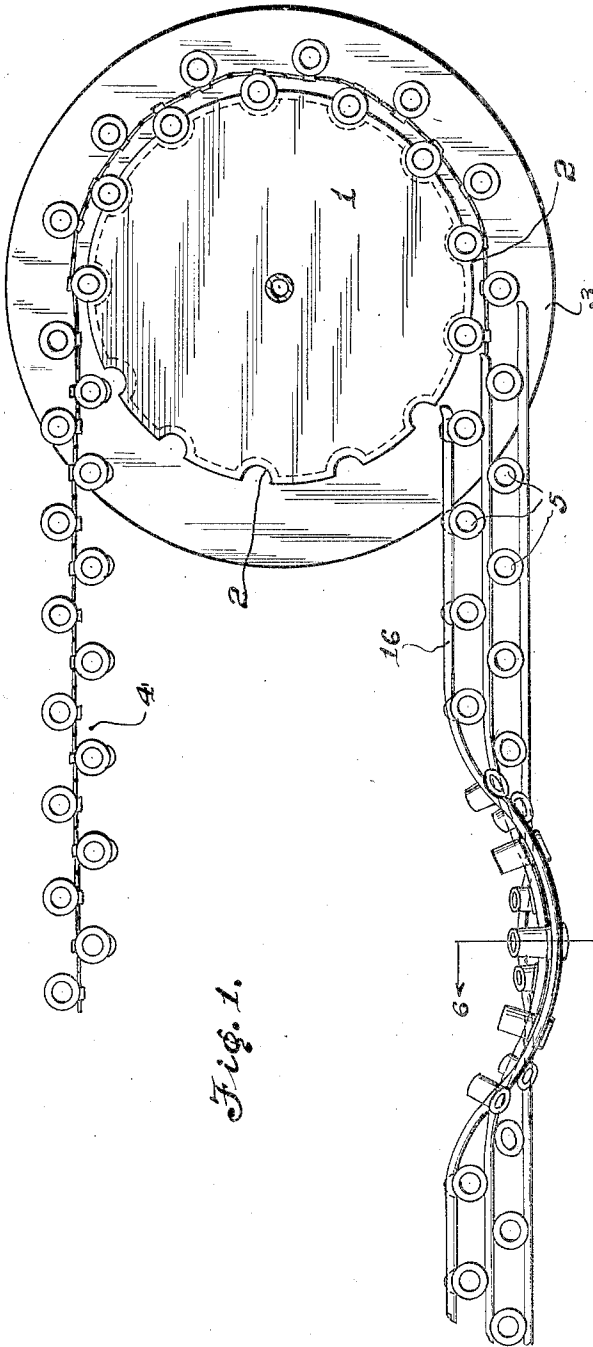

Fig. 1.

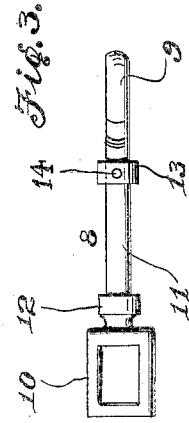

Fig. 3.

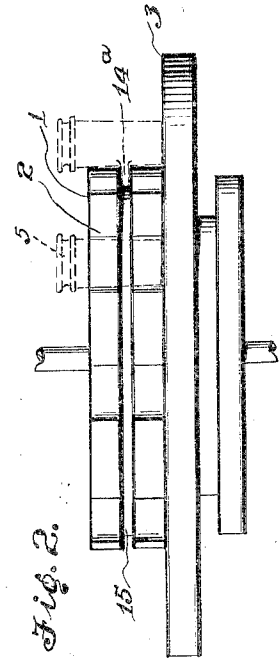

Fig. 2.

Inventor
Samuel H. Marsh

By George A. Purost

Attorney

Dec. 6, 1927.

1,651,925

S. H. MARSH

BOTTLE WASHING MACHINE

Filed Sept. 13, 1924

2 Sheets-Sheet 2

Fig. 4.

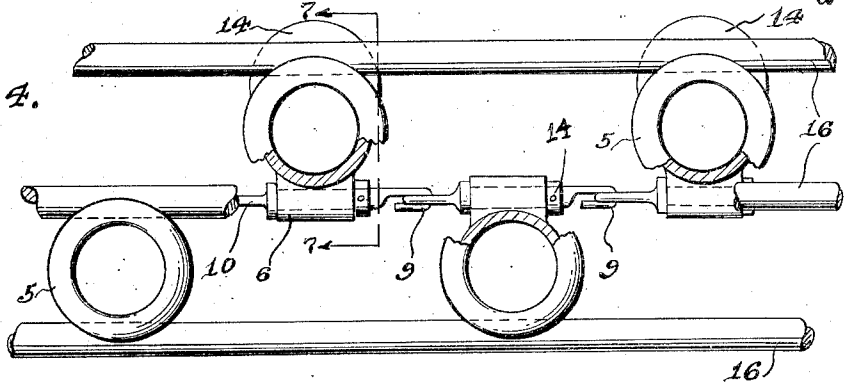

Fig. 5.

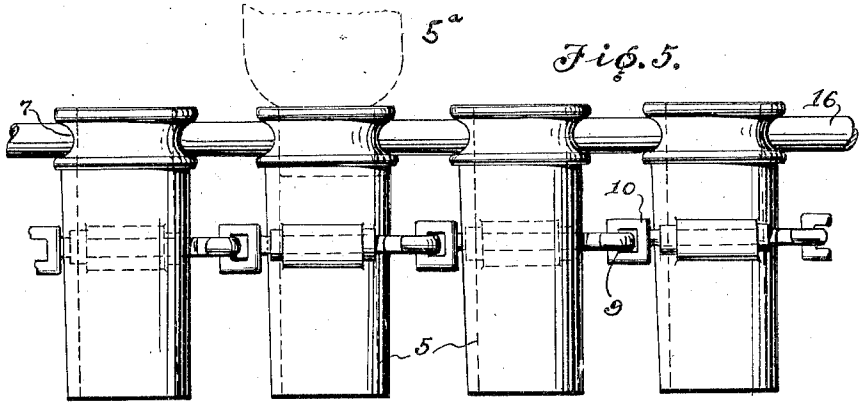

Fig. 6.

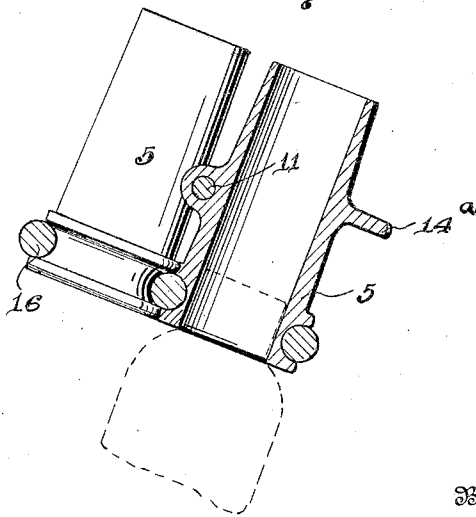
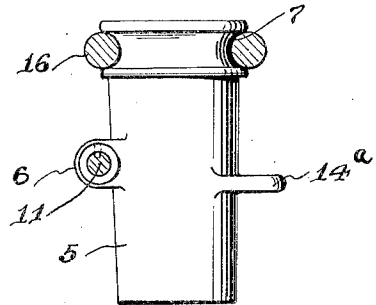

Fig. 7.



Inventor
Samuel H. Marsh

By

George A. Purser

Attorney

UNITED STATES PATENT OFFICE.

SAMUEL H. MARSH, OF AMERICUS, GEORGIA.

BOTTLE-WASHING MACHINE.

Application filed September 13, 1924. Serial No. 737,531.

My invention relates to new and useful improvements in bottle washing machines, and particularly to that class employing the sprocket wheel actuated chain of bottle conveying cups.

With the machines now in use, it is necessary to remove the bottles from the cups by hand after passing through the washing and rinsing apparatus, which operation requires many workers and obviously necessitates the expenditure of considerable time and money.

It is the object of my invention to overcome this difficulty, and to this end I provide a chain of bottle conveying cups each of which when it reaches a predetermined point, will automatically turn upon a pivot and discharge the washed bottle and return to its upright position.

Another object of my invention is to overcome the possibility of the bottle conveying chain sliding up and off of the sprocket wheel.

With the above and other objects in view which will appear as the description proceeds, my invention consists in the novel features herein set forth, illustrated in the accompanying drawings and more particularly pointed out in the appended claims.

Referring to the drawings, in which numerals of like character designate similar parts throughout the several views,

Fig. 1 is a plan view of my apparatus showing a sprocket wheel and cup tilting tracks.

Fig. 2 is a side view of the wheel, showing the lug retaining groove and the cup lug with relation thereto.

Fig. 3 is a detail view of one of the cup pivot links.

Fig. 4 is a plan view of a chain of cups showing the lug on the wheel engaging cups, and the pivot links in use.

Fig. 5 is a side view of Fig. 4.

Fig. 6 is a section taken on line 6—6, Fig. 1, showing the cups inverted, and

Fig. 7 is a view taken on line 7—7 of Fig. 4.

In the drawings, 1 designates a power driven sprocket wheel of the usual type, at one end of the apparatus having cup engaging recesses 2 and a flange or chain supporting member 3. 4 represents a chain of bottle conveying cups which consists of a series of vertically arranged cylindrical cups 5, preferably flaring toward their tops to re-

ceive the bottle necks 5^a, and being provided with laterally disposed bearings 6 integral therewith, as shown in Figs. 4 and 7. At the top of each cup 5, I provide a groove 7, extending circumferentially thereof, which will be referred to later. This chain of cups 4 may be supported by any desired means.

8 represents my novel pivot link, comprising a hook member 9 at one end and a corresponding hook receiving loop 10 at the other. Intermediate the members 9 and 10 is a cylindrical bearing member 11, provided with an integral flange 12. This link is adapted to be inserted in the bearing 6 of the cup 5 until the flange 12 abuts the end of said bearing, as shown in Fig. 4, and a removable collar 13, having a set screw 14 therein is slipped on and the set screw tightened.

After the links are arranged in the bearings of all of the cups, the hook member 9 of each is inserted in the loop member 10 of the adjacent cup as shown in Fig. 4, so as to form two rows in the single chain.

On the inner or wheel engaging row of cups, I provide lugs 14^a integral therewith and extending partially around each cup, and adapted to engage a groove 15 in the wheel 1, to prevent the chain from rising on the said wheel.

16 represents a series of cup guides comprising three rails arranged side by side at a predetermined location on the apparatus, and extending longitudinally for a portion of their length, then being bent outwardly and downwardly and back again to their longitudinal position. These tracks or guides are adapted to engage the grooves 7 of the cups 5, before referred to, and as the cups approach the bent section they will turn on their pivots 11, and be gradually inverted as shown in Figs. 1 and 6, discharging the bottles and then return to their original upright position.

The operation of my invention is obvious, the bottles 5^a are inverted and their necks inserted in said cups 5, as shown in dotted lines in Fig. 5, and are conveyed by the chain and sprocket wheel through a washing and rinsing apparatus (not shown) which may be of any suitable type. As the wheel 1 turns, it gradually brings the cups bearing the washed bottles into engagement with the guides 16, which, as before described, tilt the cups to discharge the bottles as the

cups reach the bent portions. As the chain moves onward the cups are returned to their original upright positions on the chain.

From the foregoing, it is believed that my invention may be clearly understood without further description, and in closing it may be stated that numerous changes may be made in the details of my device without departing from the spirit of the invention as disclosed in the appended claims.

What I claim and desire to secure by Letters Patent is:—

1. A bottle washing machine including a chain of bottle conveying cups, a sprocket wheel for driving said chain, a groove around the periphery of said wheel, said cups being provided with lugs adapted to engage said groove, laterally extending bearings on said cups, pivot links adapted to be inserted in said bearings, said cups being provided with grooves extending circumferentially of the tops thereof, guides adapted to engage said cup grooves and turn said cups on said pivots for discharging the washed bottles, said guides also serving to return said cups to their original upright positions.

2. A bottle washing machine including a chain of bottle conveying cups pivotally mounted to rotate on the links of said chain at an angle to the line of movement of said chain, means for driving said chain, and means for tilting said cups for discharging the bottles.

3. In combination with a bottle washing machine, a conveyor chain consisting of a plurality of links, a portion of each of said links forming a swivel, a plurality of bottle conveying cups each being provided with a bearing adapted to engage and rotate on said swivels, means for driving said chain, and means for tilting said cups for discharging the bottles.

4. In combination with a bottle washing

machine, a conveyor chain consisting of a plurality of links, a portion of each of said links forming a short shaft, a plurality of bottle conveying cups, each being provided with a bearing member adapted to engage and rotate on said shafts, each of said cups being alternately disposed on said chain with relation to the adjacent cup, means for driving said chain, and means for tilting said cups for discharging the bottles.

5. In combination with a bottle washing machine, a conveyor chain consisting of a plurality of links, a portion of each of said links forming a short shaft, a plurality of bottle conveying cups, each being provided with a bearing member, and a groove around its upper extremity, each of said bearing members being adapted to engage and rotate on the short shaft of one of said links, a plurality of guide rails adapted to register with and engage said grooves in the cups, said rails being bent at predetermined points for tilting said cups to discharge the bottles, and means for driving said chain.

6. A bottle washing machine including a chain of pivotally mounted bottle conveying cups, a sprocket wheel for driving said chain having a groove around its periphery, certain of said cups having lugs for engaging said groove, whereby said chain is prevented from moving axially of said wheel.

7. A conveyor for bottle washing machines, comprising a chain of links, each of said links being provided with connecting elements at its opposite ends, a short shaft interposed between said elements, and a plurality of bottle conveying cups, each being provided with a bearing member adapted to engage and rotate on the short shafts of said links.

In testimony whereof I affix my signature.

SAMUEL H. MARSH.