

(19)



(11)

EP 3 133 026 B1

(12)

EUROPEAN PATENT SPECIFICATION

(45) Date of publication and mention of the grant of the patent:
14.02.2018 Bulletin 2018/07

(51) Int Cl.:
B65D 41/12 ^(2006.01) **B65D 41/42** ^(2006.01)
B65D 41/58 ^(2006.01)

(21) Application number: **15779822.4**

(86) International application number:
PCT/ES2015/070186

(22) Date of filing: **17.03.2015**

(87) International publication number:
WO 2015/158942 (22.10.2015 Gazette 2015/42)

(54) **CAP FOR GLASS BOTTLES**

VERSCHLUSSKAPPE FÜR GLASFLASCHEN

BOUCHON POUR BOUTEILLES EN VERRE

(84) Designated Contracting States:
AL AT BE BG CH CY CZ DE DK EE ES FI FR GB GR HR HU IE IS IT LI LT LU LV MC MK MT NL NO PL PT RO RS SE SI SK SM TR

(30) Priority: **15.04.2014 ES 201430560**

(43) Date of publication of application:
22.02.2017 Bulletin 2017/08

(73) Proprietor: **Clipps Aluminium International, S.L.**
46014 Valencia (ES)

(72) Inventor: **MARTÍNEZ RAMÍREZ, Vicente**
E-46014 Valencia (ES)

(74) Representative: **Sahuquillo Huerta, Jesús**
Apartado de Correos, 30
28300 Aranjuez (ES)

(56) References cited:
EP-A1- 0 594 494 WO-A1-92/16426
WO-A1-92/16426 WO-A1-2012/013839
US-A- 3 109 549 US-A- 3 208 617
US-A- 3 217 916

EP 3 133 026 B1

Note: Within nine months of the publication of the mention of the grant of the European patent in the European Patent Bulletin, any person may give notice to the European Patent Office of opposition to that patent, in accordance with the Implementing Regulations. Notice of opposition shall not be deemed to have been filed until the opposition fee has been paid. (Art. 99(1) European Patent Convention).

Description

TECHNICAL FIELD

[0001] The object of the present invention relates to a cap for glass bottles that is easy to handle and provides for opening glass bottles without having to use tools of any type.

PRIOR ART

[0002] A wide range of caps for glass bottles are known today whose function is to prevent on the one hand the liquid contained therein from spilling out and, on the other, to preserve the properties of the liquid contained therein.

[0003] The so-called "crown cap" is among the most commonly used types of caps in the prior art. This type of cap is generally metallic and its main feature is that it fits to the outer contour of the rim of the opening of the bottle as a result of the presence of creases made in the cap itself when it is fixed by industrial means on said rim or opening of the bottle. Some examples of these caps are disclosed in patent documents US 1,074,907, US 1,580, 544 and US 1,155,890.

[0004] These known caps, which are standard as regards their use on the market, have the main drawback that an external tool or opener is necessary for removing them from the bottle since any manual tampering that allows opening them is impossible as a result of the aforementioned creases.

[0005] Caps or lids that are screwed onto the neck of the bottle, which obviously requires making a threading in the cap or lid and another threading on the opening of the bottle or neck thereof, are also known in the prior art.

[0006] Caps that are coupled to the neck of the bottle and retained and fixed to said opening through a ring are also known, where a given force must be exerted in order to remove said ring and thereby open it, which is not usually altogether easy, and on some occasions it may be necessary to ultimately use an external tool suitable for effectively opening it, particularly when the ring breaks.

[0007] To solve the aforementioned problems, patent document ES2381727, which belongs to the same inventors as the present invention, discloses a lid for glass bottles, preferably made of aluminum or any other type of suitable plastic material, characterized in that it is formed from an inverted cup-like body, with skirting or an annular outer flange for being fitted on the outer surface of the corresponding rim of the neck of the bottle to be sealed; the body having a concentric annular V-shaped rib fitting onto the inner contour of the opening of the neck of the bottle, said rib defining an upwardly domed surface.

[0008] Likewise, patent application WO201213839 also shows a solution disclosing a lid for glass bottles, preferably made of metal or any other type of suitable plastic material, comprising a body with skirting or an outer flange that is segmented by conical slits, characterized

in that said flange comprises a plurality of longitudinal conical grooves transverse to the axis of the lid and running around the periphery of the flange, being configured to fit onto the outer surface of the rim of the neck of the bottle to be sealed; the body having a concentric annular V-shaped rib fitting onto the inner contour of the opening of the neck of the bottle, which has a liner, said rib defining an upwardly domed surface.

[0009] Nevertheless, and despite the fact that said patent documents considerably improve the prior art as regards the need to use tool for opening bottles (whether said tool is external or a built-in ring), said structure, however, does not allow withstanding the internal pressures due to the carbon gas present in carbonated beverages or generated during industrial pasteurization processes.

[0010] Document WO92/16426 discloses a bottle cap that is openable merely by a finger pressure on a domed top side of the cap, whereby it is possible to provoke an expansion of the depending, axially presplit cap skirt portion. This type of caps, however, has not been used in practice, because the caps, due to the segmented skirt, cannot resist any noticeable overpressure in the bottles. By the present invention it has been found that this problem is not due of the segmentation as such, but rather to the fact that the ends of the skirt segments are brought to overlap each other when the cap is closed, whereby the closing effect of the skirt is weakened. On this background the invention provides for a cap, in which the ends of the skirt segments are stabilized against overlapping, e.g. in that at each slit they are shaped with respective counter phased wells. Hereby the caps will be mountable by a fully conventional equipment and - despite being easy to open - they will resist a considerable pressure in the bottles.

[0011] Document US3217916 discloses a cap according to the preamble of claim 1, with manually removable tabs in the skirt portion of the crown, in combination with an ordinary inner pressure seal and an intermediate sealing member disposed between the sealant and the inner surface of the crown.

DISCLOSURE OF THE INVENTION

[0012] The present invention relates to a cap for glass bottles, as described in claim 1 enclosed with the present specification and incorporated herein by reference. The dependent claims show particular solutions of the cap which are also incorporated herein by reference.

[0013] One object of the present invention relates to a cap for glass bottles that solves the aforementioned problems and whose structure furthermore allows withstanding the pressure of carbon gas contained or generated during the different beverage treatment processes. The possibilities of using the present cap for packaging any type of beverage susceptible to being housed in a glass bottle, such as sodas, waters, beers or the like, are homogenized as a result of the cap described in the present invention.

[0014] As a result of its particular design and shape, the cap object of the invention shows good behavior with respect to the carbon gas contained in beverages housed in glass bottles, preventing it from internally doming, which would make it difficult to open.

[0015] Likewise, by including the cap herein proposed, the pressure for opening the bottle will be applied for the most part to the central part of the cap, which in turn means that the force exerted for opening it will be less, increasing the number of potential users (since even less force is required for opening it) to segments of the population who, for physical reasons (children, the elderly), have the most difficult time at present opening containers of this type.

[0016] As a result, the cap herein describes allows withstanding pressures of up to seven bar, which increases the possibilities of said cap being used in any industrial beverage bottling process.

[0017] Once the cap is used and has been opened, it takes on a visible and characteristic triangular shape, such that reuse thereof is prevented, thereby increasing its hygiene performance.

[0018] Throughout the description and the claims the word "comprises" and variants thereof are not meant to exclude other technical features, additions, components or steps. For the persons skilled in the art, other objects, advantages and features of the invention will be inferred in part from the description and in part from putting the invention into practice. The following examples and drawings are provided by way of illustration and do not mean to restrict the present invention.

DESCRIPTION OF THE DRAWINGS

[0019] A series of drawings that help to better understand the invention and which expressly relate to an embodiment of said invention provided as a non-limiting example thereof is very briefly described.

Figure 1 shows an exploded top view of the cap for glass bottles, object of the present invention.

Figure 2 shows an exploded bottom view of the cap for glass bottles.

Figure 3 shows a view of the cap for glass bottles from the lower part thereof.

Figure 4 shows a second view of the cap for glass bottles from the lower part thereof.

Figure 5 shows a plan view of the lower part of the cap.

DETAILED DISCLOSURE OF THE INVENTION

[0020] The attached drawings show a preferred embodiment of the invention. More specifically, the cap for

glass bottles comprises a body (1) with skirting (2) with at least three cuts (3) made from the outside of the skirting (2) to the inside of the body (1) in which a core (4) is provided and to which pressure is applied for opening the cap herein described.

[0021] At least three reinforcements (5) in the form of ribs are reinforcing the core, the function of which is to provide greater robustness to the assembly and prevent excessive deformation of the body (1) since said reinforcements (5) do not deform during opening.

[0022] A first concave region (4a) that coincides with a second concave region (6a) arranged in the opposite position and which is an integral part of a second body (6) integrally attached to the first body (1), is provided on the inside of the body (1) and coinciding with the position of the core (4).

[0023] Both concave regions (4a, 6a) opposite one another create a chamber or space that allows the tilting of the cap during the deformation thereof when opening it, in addition to providing certain safety to the cap itself since the pressure to be applied on the core (4) of the first body (1) while opening is homogenized, regardless of the internal pressure withstood by the cap.

[0024] The second body (6) comprises a flange (7) around the periphery configured, on the one hand, for fitting onto the outer surface of the rim of the bottle, and on the other, onto the skirting (2) of the body (1), creating the mentioned second concave region (6a) in the central part therein.

[0025] In turn, the entire periphery of said flange (7) incorporates a plurality of cuts (7a) which prevent resistance when opening, and accordingly make opening easier.

[0026] The second body (6) also comprises in the lower part thereof a threaded area (8) in turn defining a plurality of crests (8a) improving grip on the neck of the bottle and providing the sealing required for properly preserving the liquid contained in the bottle and its properties.

[0027] Finally, contiguous to said threaded area (8) there is provided a plurality of spokes (9) in the form of reinforcement which help to improve the results with respect to internal pressure.

[0028] In a practical embodiment, the body (1) and the second body (6) are made forming a single body.

[0029] In a particular embodiment, the body (1) will have a series of grooves along the skirting (2) thereof making it easier to seal it during the industrial bottling process.

Claims

1. A cap for glass bottles, comprising a first body (1) and a second body (6) integrally attached to the first body (1), wherein:

a) the first body (1) comprises:

- a. a skirting (2) with at least three cuts (3) made from the outside of the skirting (2) to the inside of the body (1); **characterised in that** the first body further comprises:
- b. a core (4) with at least three reinforcement ribs (5) arranged to not deform during opening; 5
- c. a first externally concave region or area (4a) provided inside the first body (1) and coincident with the position of the core (4); 10
- b) the cap being further **characterised in that** the second body (6) comprises:
- a. a flange (7) incorporating a plurality of cuts (7a) around the periphery configured for: 15
- i. fitting onto the outer surface of a rim of the glass bottle; 20
- ii. fitting onto the skirting (2) of the body (1) creating a second externally concave region (6a) in the central part therein; 25
- b. a threaded region (8) in the lower part of the second body (6) in turn comprising:
- i. a plurality of crests (8a) improving grip on a neck of the glass bottle and providing the sealing required for properly preserving a liquid contained in the bottle; and 30
- c. a plurality of reinforcement spokes (9) contiguous to the threaded region (8); 35
- wherein the first concave region or area (4a) that coincides with the second concave region or area (6a) are opposite one another, such that they define a chamber or space there between configured for the tilting of the edge of the cap during the deformation thereof in the process of opening it. 40
2. The cap according to claim 1, wherein the body (1) has a plurality of grooves along its skirting (2). 45
3. The cap according to any of the preceding claims, wherein the body (1) and the second body (6) are integrated into a single body. 50

Patentansprüche

1. Kappe für Glasflaschen, bestehend aus einem ersten Körper (1) und einem zweiten Körper (6), der integral an den ersten Körper (1) angebracht ist, wobei: 55

a) der erste Körper (1) besteht aus:

- a. einer Schürze (2) mit mindestens drei Einschnitten (3), die von der Außenseite der Schürze (2) zur Innenseite des Körpers (1) verlaufen; **gekennzeichnet dadurch, dass** der erste Körper ferner umfasst:
- b. einen Kern (4) mit mindestens drei Verstärkungsrippen (5), die so angeordnet sind, dass sie sich beim Öffnen nicht verformen;
- c. einen ersten äußeren konkaven Bereich (4a), der innerhalb des ersten Körpers (1) vorgesehen ist und mit der Position des Kerns (4) zusammenfällt;

b) wobei die Kappe weiterhin **dadurch gekennzeichnet ist, dass** der zweite Körper (6) besteht aus:

- a. einem Flansch (7), der zahlreiche Einschnitte (7a) um den Umfang herum aufweist und konfiguriert ist für:
- i. das Aufsetzen auf die äußere Oberfläche des Randes einer Glasflasche;
- ii. das Aufsetzen auf die Schürze (2) des Körpers (1), wodurch ein zweiter äußerer konkaver Bereich (6a) im mittleren Teil entsteht;
- b. einem Gewindebereich (8) im unteren Teil des zweiten Körpers (6), der seinerseits umfasst:
- i. zahlreiche Kuppen (8a), die den Griff am Hals der Glasflasche verbessern und die Abdichtung gewährleisten, die zum ordnungsgemäßen Aufbewahren einer Flasche mit Flüssigkeit erforderlich ist; und
- c. zahlreiche Verstärkungsspeichen (9), die an den Gewindebereich (8) angrenzen ;

wobei der erste konkave Bereich (4a) und der zweite konkave Bereich (6a) übereinstimmen und einander gegenüberliegen, so dass zwischen diesen eine Kammer bzw. ein Raum entsteht, der für die Neigung des Randes der Kappe vorgesehen ist, der bei der Verformung der Kappe während des Öffnungsprozesses entsteht.

2. Kappe nach Anspruch 1, wobei der Körper (1) zahlreiche Nuten entlang seiner Schürze (2) aufweist.
3. Kappe nach einem der vorhergehenden Ansprüche, wobei der Körper (1) und der zweite Körper (6) in

einen einzigen Körper integriert wurden.

Revendications

1. Bouchon pour bouteilles en verre comprenant un premier élément (1) et un deuxième élément (6) fixé intégralement au premier élément (1), dans lequel :

a) le premier élément (1) comprend :

a. une jupe (2) avec au moins trois entailles (3) réalisées de l'extérieur de la jupe (2) à l'intérieur de l'élément (1); **caractérisée en ce que** le premier élément comprend en outre :

b. un noyau (4) avec au moins trois nervures de renforcement (5) disposées de manière à ne pas se déformer pendant l'ouverture ;
c. a une première partie ou surface extérieurement concave (4a) située à l'intérieur du premier élément (1) et coïncidant avec la position du noyau (4);

b) le bouchon étant en outre **caractérisé en ce que** le deuxième élément (6) comprend:

a. une ailette (7) comportant une diversité de rainures (7a) autour de la périphérie configurée pour :

i. le montage sur la surface extérieure du rebord de la bouteille en verre ;
ii. pour s'emboîter sur la jupe (2) de l'élément (1), créant une seconde zone extérieurement concave (6a) dans la partie centrale de ladite ;

b. une partie filetée (8) dans la partie inférieure du deuxième élément (6) comprenant à son tour:

i. une diversité de crêtes (8a) améliorant l'adhérence sur le goulot de la bouteille en verre et assurant l'étanchéité requise pour conserver correctement le liquide contenu dans la bouteille; et

c. une diversité de rayons de renforcement (9) contigus à la zone filetée (8);

dans laquelle la première partie ou surface concave (4a) qui coïncide avec la deuxième partie ou surface concave (6a) sont opposées l'une à l'autre, de telle sorte qu'elles définissent une cavité ou un espace entre elles configurées pour l'inclinaison du bord du bouchon pendant la déformation de celui-ci au cours du processus d'ouverture.

2. Le bouchon selon la demande 1, dans lequel l'élément (1) présente une diversité de rainures le long de sa jupe (2).

3. Le bouchon selon l'une des revendications précédentes, dans lequel l'élément (1) et le deuxième élément (6) sont intégrés dans un seul élément.

10

15

20

25

30

35

40

45

50

55

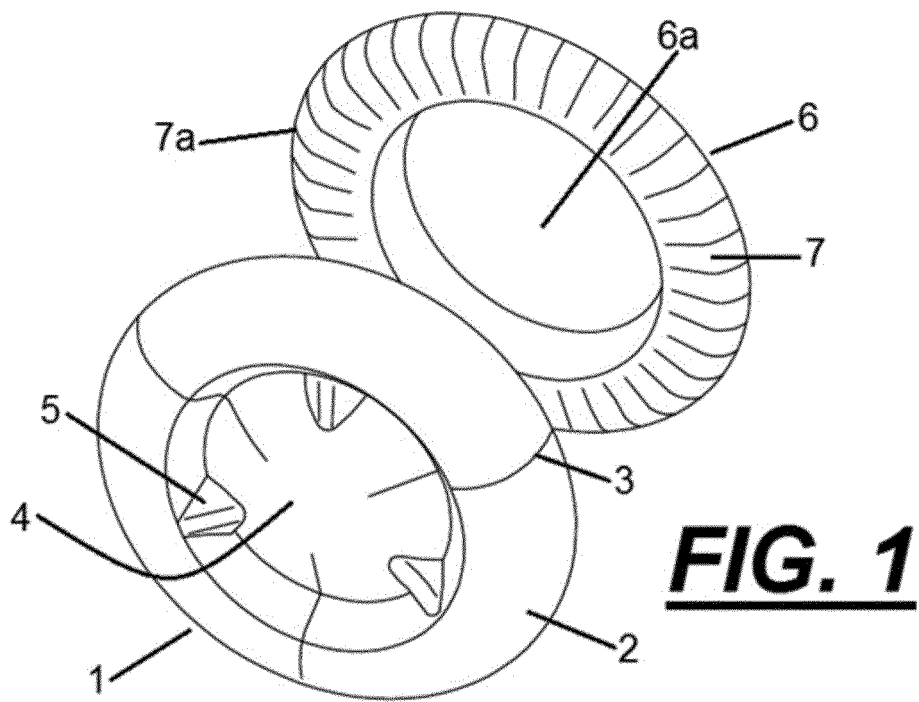

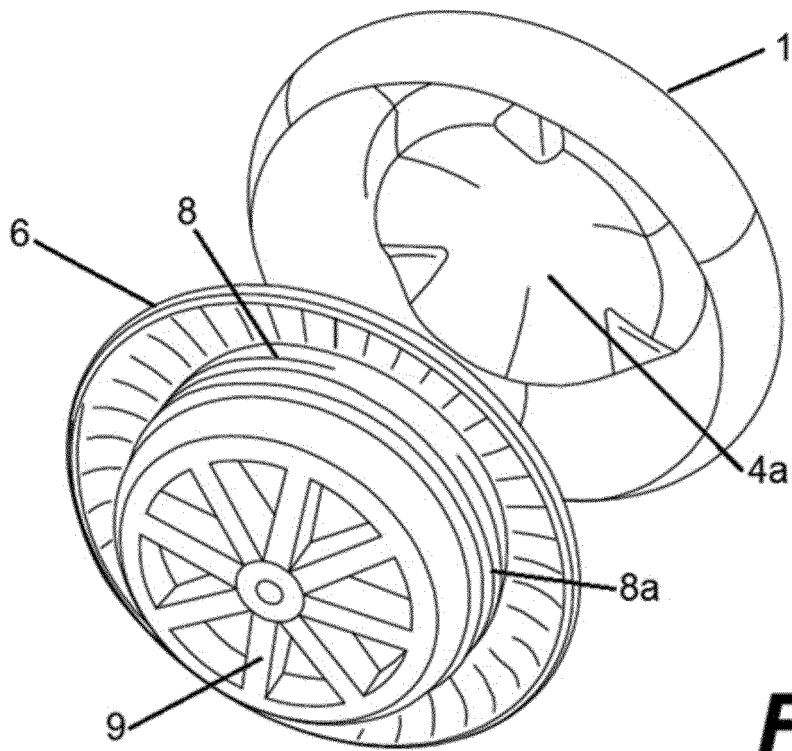

FIG.2

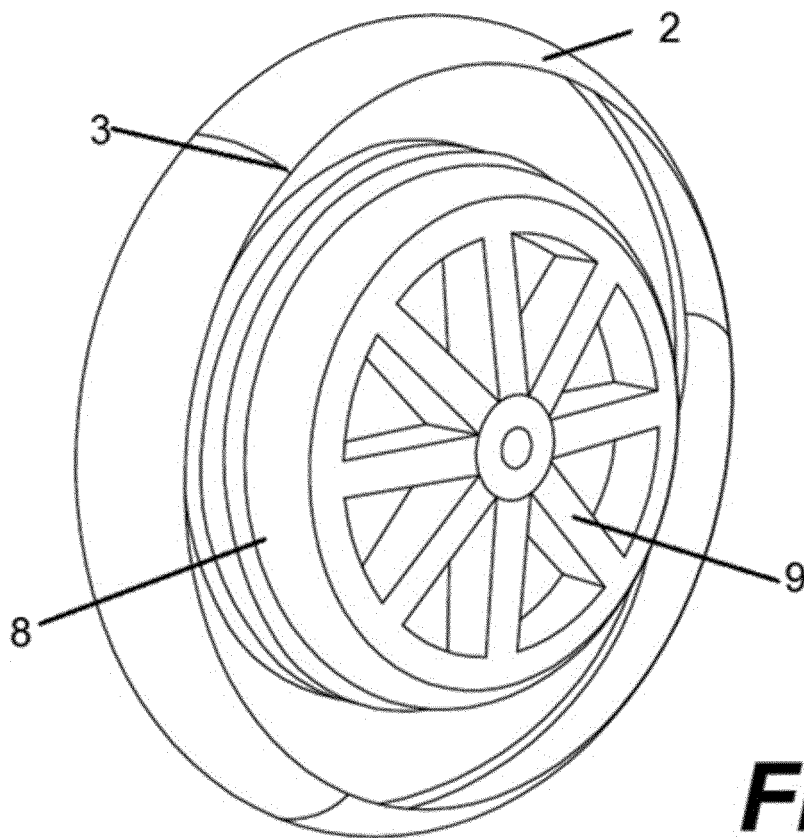

FIG.3

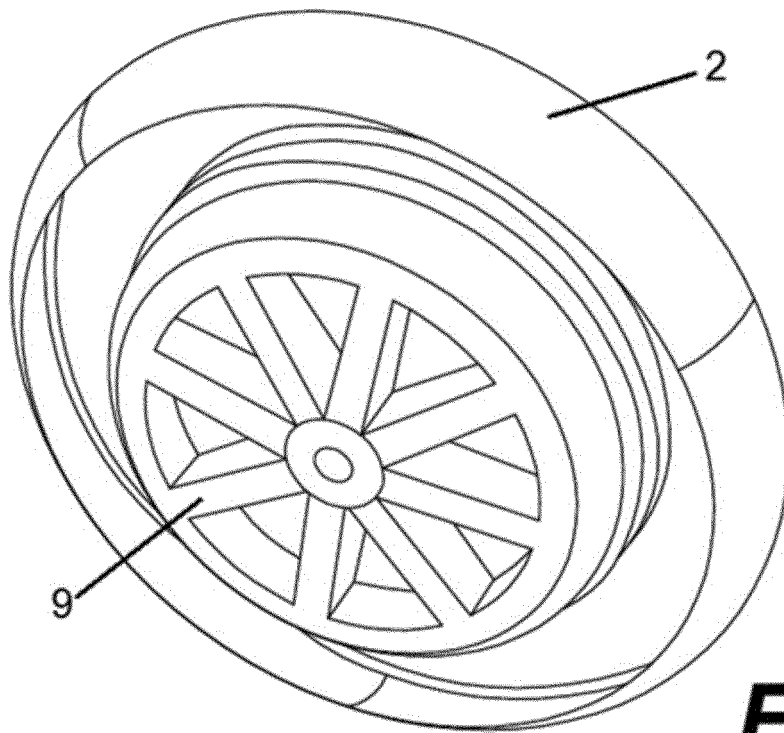

FIG.4

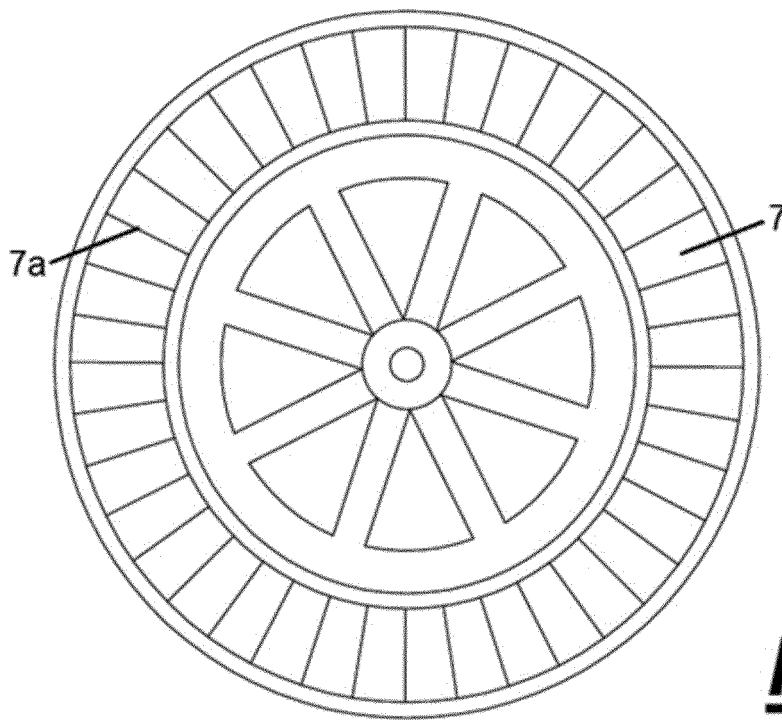

FIG.5

REFERENCES CITED IN THE DESCRIPTION

This list of references cited by the applicant is for the reader's convenience only. It does not form part of the European patent document. Even though great care has been taken in compiling the references, errors or omissions cannot be excluded and the EPO disclaims all liability in this regard.

Patent documents cited in the description

- US 1074907 A [0003]
- US 1580544 A [0003]
- US 1155890 A [0003]
- ES 2381727 [0007]
- WO 201213839 A [0008]
- WO 9216426 A [0010]
- US 3217916 A [0011]