

Nov. 5, 1963

G. T. ANDERSSON ETAL

3,109,344

LOADING RACK FOR AMMUNITION CARTRIDGES

Filed Dec. 29, 1960

FIG. 1

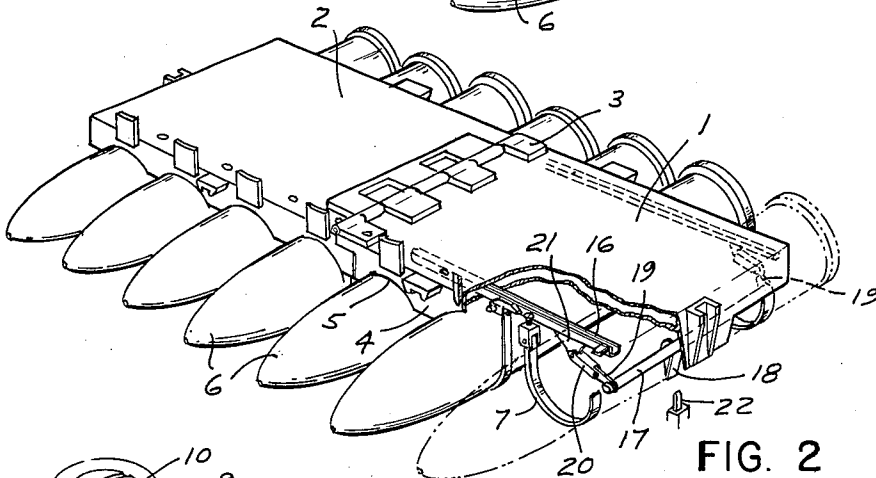
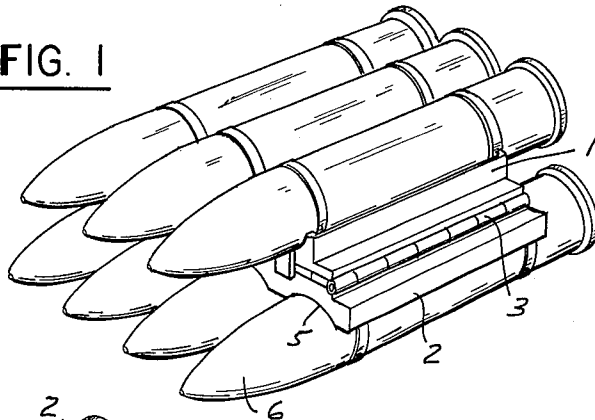

FIG. 2

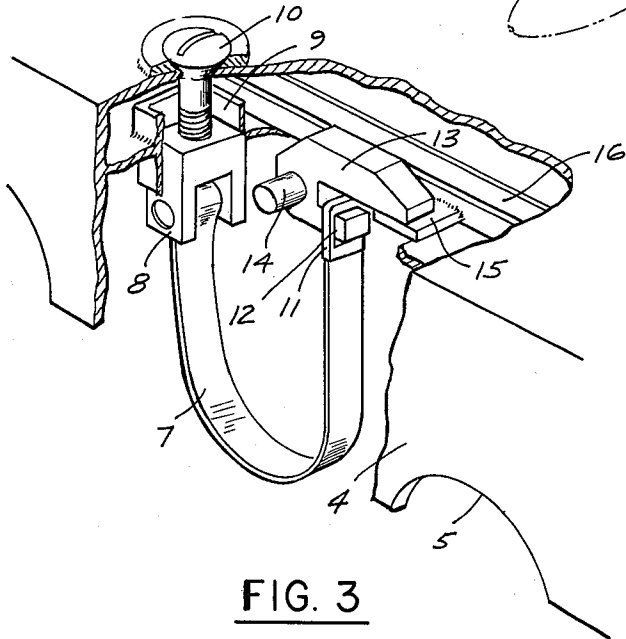

FIG. 3

INVENTORS  
GUSTAV TORE ANDERSSON  
GUSTAF OLOF ENGMAN

BY *Hane and Rydick*

ATTORNEYS

1

2

3,109,344  
LOADING RACK FOR AMMUNITION  
CARTRIDGES

Gustav Tore Andersson, Karliskoga, and Gustaf Olof Engman, Bofors, Sweden, assignors to Aktiebolaget Bofors, Bofors, Sweden, a Swedish company

Filed Dec. 29, 1960, Ser. No. 79,263

Claims priority, application Sweden Jan. 5, 1960  
6 Claims. (Cl. 89-34)

The present invention relates to a loading rack for the transport of ammunition cartridges, and more particularly, to a loading rack for feeding comparatively heavy cartridges disposed in parallel to the magazine of an automatic portable gun.

The feeding of heavy cartridges to automatic movable guns presents certain inherent technical and tactical problems. On the one hand, due to the weight of the cartridges the magazine of the gun cannot be designed to hold many cartridges and on the other hand, manual feeding at the required rate is not practical for reasons of weight.

It is the broad object of the present invention to provide a novel and improved ammunition loading rack which permits rapid feeding of comparatively heavy cartridges to an automatic portable or movable gun.

A more specific object of the invention is to provide an ammunition loading rack which can be loaded at any convenient location remote from the gun and from which a plurality of cartridges can be released simultaneously in the correct position for placement in the magazine of the gun.

Another more specific object of the invention is to provide a loading rack of the general kind above referred to, which is foldable in loaded condition, thereby facilitating storage and transportation of the rack.

Other and further objects, features and advantages of the invention will be pointed out hereinafter and set forth in the attached claims forming part of the application.

In the accompanying drawing, a preferred embodiment of the invention is shown by way of illustration and not by way of limitation.

In the drawing:

FIG. 1 is a perspective view of a loaded rack in its folded condition.

FIG. 2 is a perspective view of the loaded rack ready for release of cartridges from the rack, and

FIG. 3 is a fragmentary perspective view, partly in section, of the rack on an enlarged scale.

Referring now to the figures in detail, the exemplified loading rack according to the invention comprises a support frame composed of two similar parts, 1 and 2, hinged together by means of a hinge 3. The hinge permits folding of the rack from the position of FIG. 2 into the position of FIG. 1 in which the top sides of the two parts face each other. The frame has a preferably generally rectangular configuration and is formed with flanges 4 depending from the bottom side of the frame when the same is in its operational position, generally a substantially horizontal position. The flanges at both sides of the frame are formed with lengthwise spaced, generally semi-circular recesses 5. The recesses are shaped and spaced to accommodate and locate the cartridges to be stored in the rack. As can be seen in FIGS. 1 and 2, the cartridge case 6 is received in the rearward recesses (as seen in the drawing) and the projectile 6 of the cartridges is received in the forward recesses. To lock and locate the cartridges in the recesses lengthwise, the projectile portions are preferably provided with circumferential grooves. The cartridges when fitted in the recesses are disposed parallel to each other and transverse of the frame.

The cartridges are held in the recesses by suspension means. There is provided for each cartridge to be stored

a pair of flexible straps 7 made of any suitable material. One of the straps for each pair serves to hold the cartridge case 6 and the other the projectile 6. As can best be seen in FIG. 3, one end of each strap is secured to the frame by means of a fastening member 8 which is slidably guided in guide tracks 9 of generally U-shaped cross section. Each member 8 is retained within its guide tracks by a screw 10 extending through the top wall of the frame. Screw 10 permits tightening of the respective strap about the projectile by pulling member 8 upwardly in its guide tracks. The other end of each strap is releasably attached to a holder 13. Each holder is pivotally mounted on the frame by pivot pin 14 and has an arm 12 preferably terminating in a hook upon which is hooked an eyelet 11 formed at the respective end of each strap.

As can be clearly seen in FIG. 3, each holder 13 when in the position shown in that figure will retain the eyelet of the strap on its hook, but will release the eyelet when pivoted in clockwise direction. The holder is retained in its illustrated position by means of a lug 15 underlying the holder. Each lug 15 is secured to a release bar 16 which in turn is guided lengthwise slidable in the frame.

One of the aforesaid suspension means is provided for each strap on both sides of the frame. The release bars 16 extend along the length of frame part 1 and are provided with an appropriate number of control lugs 15. Similar suspension means and release bars are provided for frame part 2.

The control of release bars 16 on frame part 1 is effected by means of a control bar 17. The release bar is rotatably mounted across the respective short side of frame part 1 and has at each end secured to it a lever 19. Each lever is linked to an intermediate lever 20, which in turn is linked to a bracket 21 depending from each rail 16. Control bar 17 mounts a radially protruding arm 18 which is arranged to coact with a lug 22. One such lug should be visualized as being fixedly mounted on each side of the magazine of the gun to be serviced.

The loading rack as heretofore described is operated as follows:

Let it be assumed that the rack has been loaded and folded (see FIG. 1). To feed the gun magazine, the frame is unfolded, generally by means of a crane or hoist, so that the frame now occupies the position of FIG. 2. The entire rack is now lifted and moved by means of the hoist to the gun, with the cartridges facing downwardly and in a substantially horizontal position. Then the rack is lowered with the cartridges still in substantially horizontal position and the rack is so maneuvered that arm 18 of, say, part 1 faces lug 22. In this position of rack part 1, the same is located just above a magazine of the gun. When now arm 18 is forced against lug 22 the control bar 17 will turn in clockwise direction. As a result, both release bars of part 1 and with them lugs 15 are so displaced that all the straps of part 1 are released, thus effecting a simultaneous release of all the cartridges in part 1. The release of the cartridges in rack part 2 is controlled in the same manner and, accordingly, all the cartridges in rack part 2 can be released simultaneously with the cartridges in part 1 by coaction of the arm 18 of rack part 2 with the second magazine lug 22.

While the invention has been described in detail with respect to a certain now preferred example and embodiment of the invention it will be understood by those skilled in the art after understanding the invention, that various changes and modifications may be made without departing from the spirit and scope of the invention, and it is intended, therefore, to cover all such changes and modifications in the appended claims.

What is claimed as new and desired to be secured by Letters Patent is:

1. A loading rack for simultaneously feeding a plural-

3

ity of heavy ammunition cartridges to a magazine of an automatic gun, said rack comprising a generally plane portable support frame, a plurality of releasable cartridge suspension means depending from one side of the frame in an operational position thereof, said suspension means being oriented parallel to each other and the plane of the frame to suspend a corresponding plurality of cartridges parallel to each other in a common plane, and common release means for simultaneously releasing all said suspension means to free the cartridges from the rack for discharging the cartridges parallel to each other and in a direction perpendicular to the plane of the frame, said support frame being comprised of two parts hinged together along two adjacent edges for transverse folding of the parts from an aligned position to a superimposed position, said aligned position constituting the operational position and said folded position a storage and transport position.

2. A loading rack according to claim 1 wherein each of said suspension means comprise a pair of straps girdling a suspended cartridge at lengthwise spaced portions thereof, one end of each strap being fixedly secured to the frame and the other end being releasably attached to the frame, said release means releasing said other end of the straps upon actuation of said release means.

3. A loading rack according to claim 2 wherein each of said suspension means comprises a holder for releasably holding said other end of the strap, said holder being mounted pivotally between a position retaining said other strap end and a position releasing the same, and wherein said release means comprise a locking member for each holder supported on the frame movable between a first position locking said holder in its retaining position and a second position releasing the holder therefrom, said

4

locking member being movable from its first position into its second position by actuation of said release means.

4. A loading rack according to claim 3 wherein said pivotal holders and the movable locking members therefor are disposed along the long sides of said frame, each of said holders being pivotally secured to the frame, and a release bar mounted on each long side of the frame lengthwise slidable in reference thereto and supporting said locking members for moving the latter from said first position into said second position, and wherein said release means include actuating means coupled with said release bars to displace the same upon actuation of said actuating means thereby simultaneously releasing all the holders.

5. A loading rack according to claim 4 wherein said actuating means are disposed at one of the sides of the frame and controllable by a stationarily mounted actuator.

6. A loading rack according to claim 1 wherein separate release means are provided for each part of the frame each effecting simultaneous release of all the cartridges suspended on the respective frame part.

## References Cited in the file of this patent

## UNITED STATES PATENTS

1,231,106	Wesson	June 26, 1917
2,392,400	Neff	Jan. 8, 1946
2,406,232	Lima	Aug. 20, 1946
2,592,415	Grogan	Apr. 8, 1952

## FOREIGN PATENTS

460,150	France	Sept. 27, 1913
285,376	Great Britain	May 31, 1928