

J. SMILES.

Breech-Loading Fire-Arm.

No. 110,505.

Patented Dec. 27, 1870.

FIG I

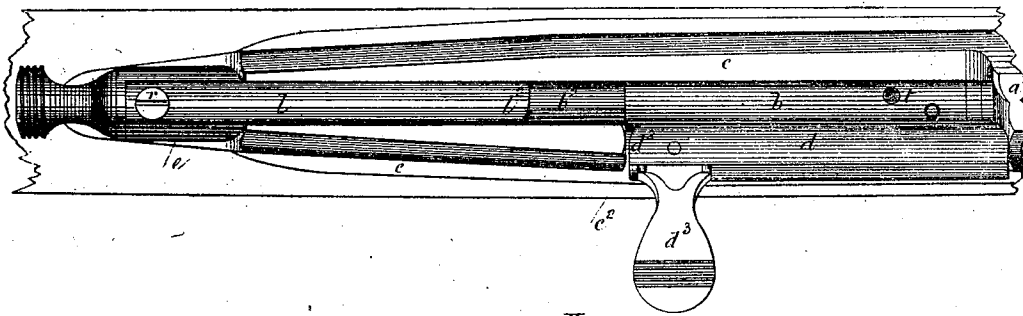

FIG II

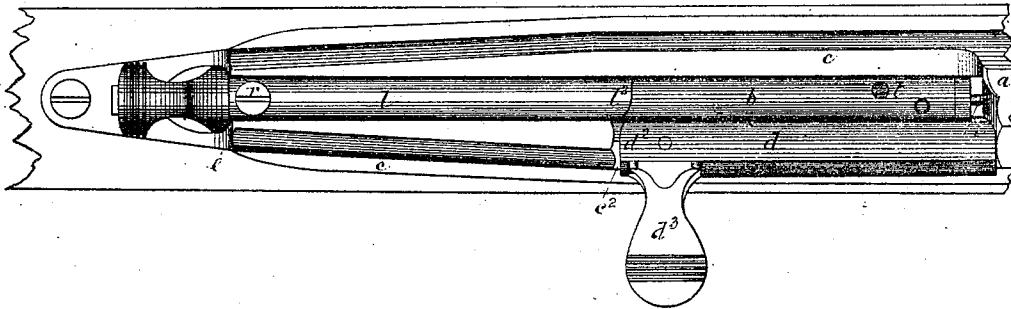

FIG III

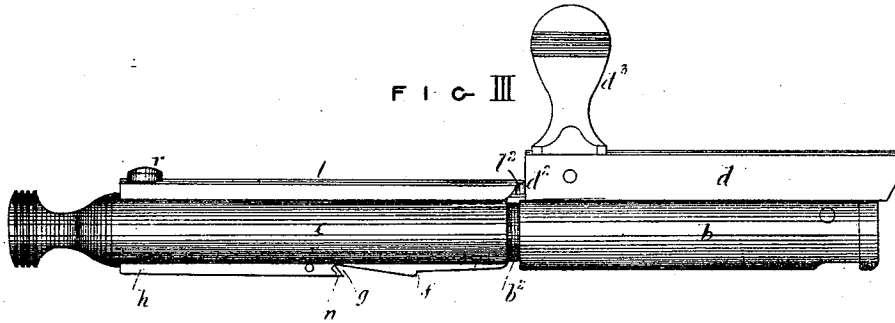
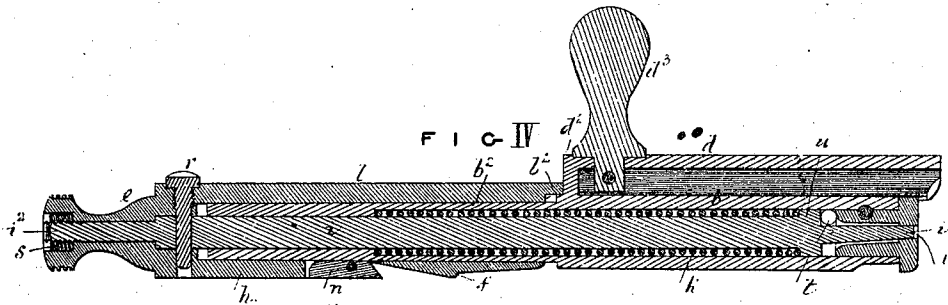

FIG IV



The Drawing referred to in the accompanying Specification.

Witnesses to the signature of James Smiles  
 George Shaw  
 Richard Kerrett

James Smiles

J. SMILES.

Breech-Loading Fire-Arm.

No. 110,505

Patented Dec. 27, 1870.

FIG V

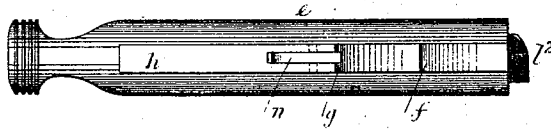

FIG VI



FIG VII

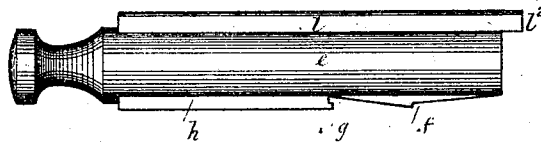

FIG VIII



FIG IX

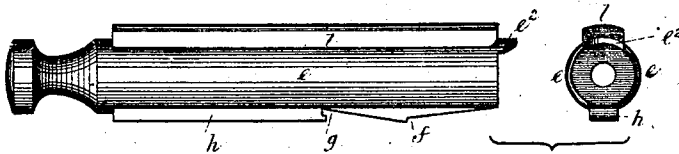
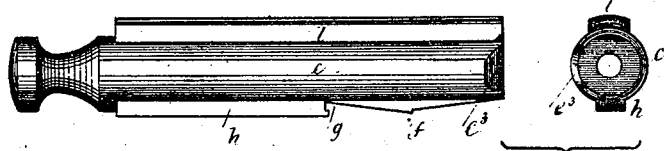

FIG X



*Witnesses to the signature of James Smiles  
George Shaw  
Richard Bennett*

*The Drawing referred to in the accompanying Specification.  
James Smiles*

J. SMILES.

Breech Loading Fire-Arm.

No. 110,505.

Patented Dec. 27, 1870.

FIG VIII

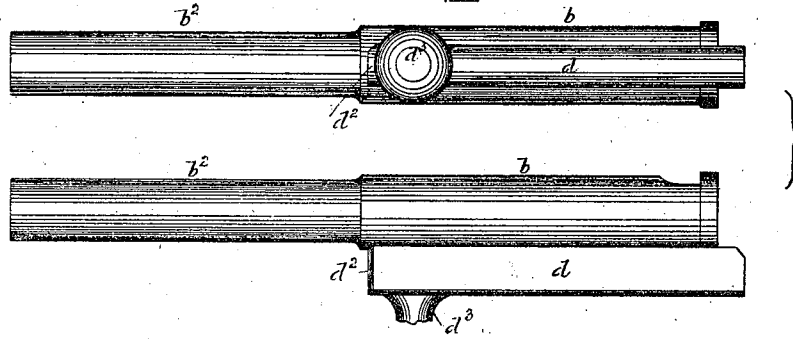

FIG XII

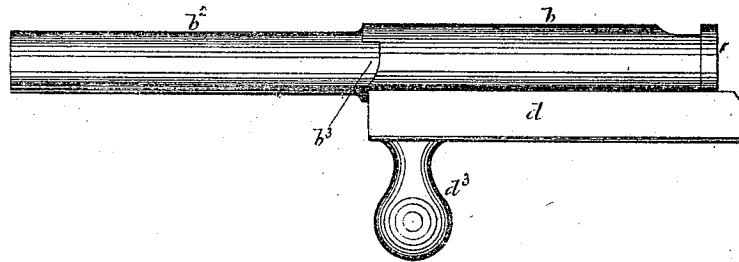
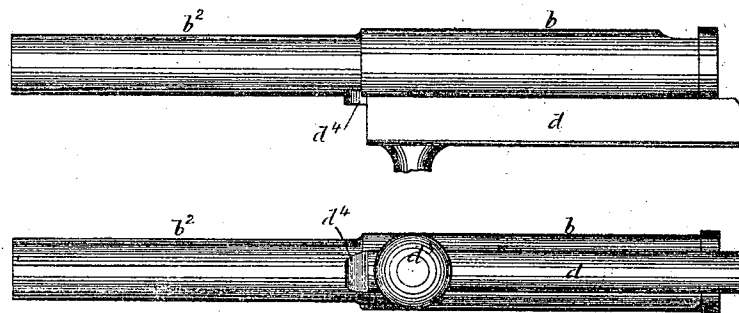

FIG XIII



The drawing referred to in the accompanying Specification  
*James Smiles.*

Witnesses to the signature of James Smiles  
*George Shaw*  
*Richard Kerrett*

J. SMILES.

Breech-Loading Fire-Arm.

No. 110,505.

Patented Dec. 27, 1870.

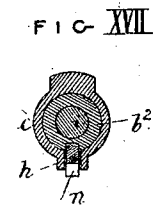
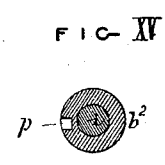
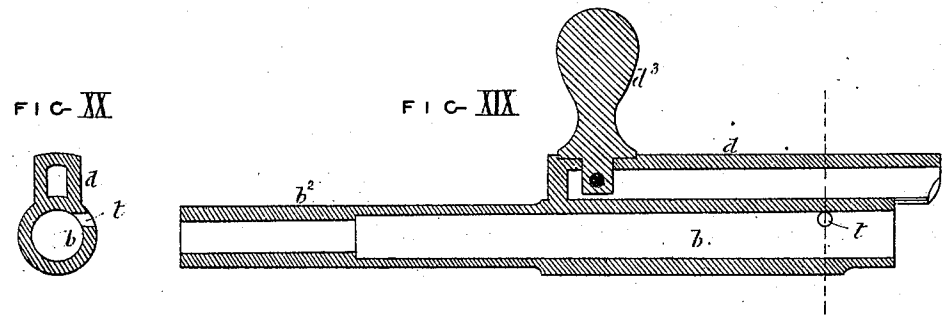
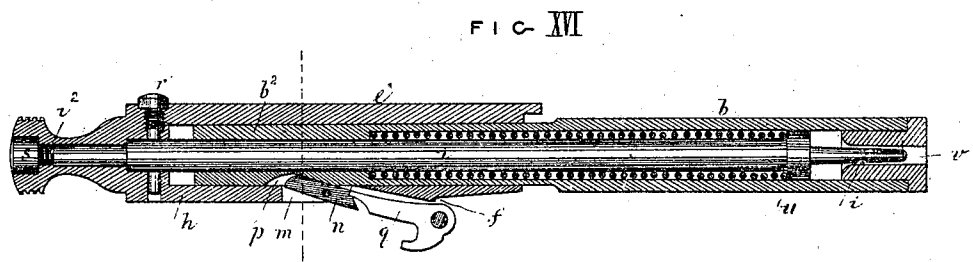
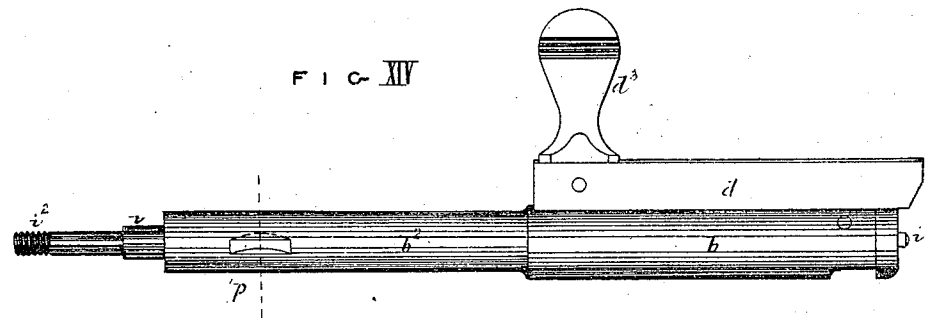

The drawing referred to in the accompanying Specification  
*James Smiles*

Witnesses to the signature of James Smiles.

*George Shaw*  
*Richard Kerrett*

# United States Patent Office.

JAMES SMILES, OF BIRMINGHAM, ENGLAND.

Letters Patent No. 110,505, dated December 27, 1870.

## IMPROVEMENT IN BREECH-LOADING FIRE-ARMS.

The Schedule referred to in these Letters Patent and making part of the same.

### To all to whom it may concern:

Be it known that I, JAMES SMILES, of Birmingham, in the county of Warwick, England, gun-maker, a subject of the Queen of Great Britain, have invented or discovered new and useful "Improvements in Breech-loading Fire-Arms;" and I, the said JAMES SMILES, do hereby declare the nature of the said invention, and in what manner the same is to be performed, to be particularly described and ascertained in and by the following statement thereof, that is to say:

My invention has reference to breech-loading fire-arms of the kind called bolt-guns, that is, guns in which the breech is opened for charging and closed for discharging by means of a cylindrical hollow bolt or plug, capable of sliding and partly rotating in the breech end of the barrel, the pin or striker for discharging the gun being carried by a sliding cylindrical sleeve or tubular collar, the fore end of which sleeve or collar works upon the rear part of the bolt or plug, which is of less diameter than the fore part.

My invention consists, first, of the following arrangement or combination of parts for preventing the accidental discharge of the gun:

The under side of the sliding sleeve, hereinbefore described, is furnished with the usual rib, in which are made the half-cock and full-cock bents for the sear to engage in to hold the discharging mechanism at half cock or full cock. In that part of the rib at which the half-cock bent is situated I make a slot, the said slot also passing through the sleeve. In this slot I place a safety-catch, consisting of a small lever, the outer end of which, when the said catch or lever is in its normal position, projects in front of the half-cock bent.

At the rear end of that part of the plug or bolt which is of less diameter, I make an opening of a size proper for the inner end of the safety-catch or lever to enter. On pushing home and locking the plug or bolt after the introduction of a cartridge into the barrel, the sleeve is left behind and the gun is cocked by the sear engaging in the full-cock bent.

In order to prevent the accidental discharge of the gun, the sleeve is put at half cock. In effecting this the nose of the sear acts upon the inclined outer end of the safety-catch or lever, and raises its inner end, which, entering the opening or recess in the reduced part of the bolt, (which has been brought opposite the said inner end of the catch by the locking of the bolt,) temporarily locks or fastens the sleeve and bolt together, and prevents the rotation of the bolt. The sleeve, and, consequently, the discharging mechanism, cannot therefore advance to discharge the gun, and great safety, in the gun is thus insured.

To discharge the gun it is only necessary to pull back the sleeve so as to engage the sear with the full-

cock bent. The upper end of the safety-catch, on being thus relieved from the action of the sear, passes out of the recess in the plug, and releases the sleeve, which can now advance to discharge the gun.

My invention consists, secondly, of the following arrangement of parts for permitting of the ready escape of the gas through the closing-bolt or plug in case imperfect cartridges are fired, that is, cartridges which allow of the passage of gas through the base:

When such cartridges are fired, the back action of the gas upon the pin or striker forces the said pin or striker violently back, and injures the mechanism of the gun. The object of this part of my invention is to remedy, wholly or mainly, this defect. I effect this by making near the front end of the closing-bolt or plug a gas-vent or hole. When the pin or striker is advanced to discharge the gun the guide-collar on the pin or striker covers the said gas-vent or hole. When, however, an imperfect cartridge is fired, the gas from the said cartridge, entering the plug or bolt through the hole in which the pin or striker works, forces back the collar of the pin or striker, and thereby uncovers the gas-vent in the plug, through which the gas rapidly escapes. The said pin or striker is thus relieved wholly or mainly from the back action of the gas, and the gun is consequently uninjured by such back action.

Having explained the nature of my invention, I will proceed to describe, with reference to the accompanying drawing, the manner in which the same is to be performed.

Figure 1 represents in plan the breech end of a breech-loading bolt-gun containing my improvements, the parts of the gun being in position for discharge; and

Figure 2 represents the same after discharge and before the handle of the closing-plug or bolt of the gun is raised to unlock the said plug or bolt.

Figure 3 represents in side elevation, and

Figure 4 in longitudinal section the plug or bolt and sleeve of the gun, detached.

Figure 5 represents a plan of the under side of the sleeve, separately.

Figure 6 represents a plan of the upper side of the said sleeve; and

Figure 7, a side elevation of the same.

Figure 8 represents a plan of the upper side and side elevation of the plug or bolt, separately.

Figures 9, 10, 11, 12, and 13 represent modifications of my improvements for withdrawing the pin or striker into a position of safety.

The other figures represent parts of the gun, as hereinafter described.

The same letters of reference indicate the same parts in the several figures of the drawing.

Before proceeding to describe my improvements, I

will briefly explain the parts of the gun and its action.

$a$  is the barrel; and

$b$   $b^2$  is the tubular plug or bolt by which the breech end is opened and closed, the said bolt being capable of sliding and partly rotating in the open breech-chamber or shoe  $c$  of the gun.

On the larger part,  $b$ , of the plug or bolt is a rib,  $d$ , to which the handle  $d^2$ , by which the plug is operated, is affixed.

The said rib  $d$ , on moving the plug to open or close the breech, works in the longitudinal opening in the rear of the breech-chamber  $c$  and the rear end of the said rib, when the plug has been pushed home and the handle  $d^2$  turned down, as seen in figs. 1 and 2, bears against the shoulder  $c^2$  of the breech-chamber or shoe  $c$ , and securely locks the plug or bolt in its place for firing. When the handle  $d^2$  is lifted into a vertical position the rib  $d$  escapes from the shoulders  $c^2$ , and the gun may be opened by sliding the plug to the rear end of the shoe or breech-chamber  $c$ .

$e$  is a sliding sleeve working upon the smaller part,  $b^2$ , of the bolt  $b$   $b^2$ .

On the under side of said sleeve is a rib,  $h$ , containing the full-cock bent  $f$  and the half-cock bent  $g$ . By the sear of the gun engaging in the bent  $g$  the gun is held at half cock, and by the sear engaging in the bent  $f$  the gun is held at full cock.

Fixed to the said sleeve  $e$ , and passing through the tubular bolt or plug  $b$   $b^2$ , is the pin or striker  $i$ , for discharging the cartridge, the said pin or striker being forced home by the coiled spring  $k$ .

The sleeve  $e$  is prevented from rotating with the bolt by the rib  $l$ , on its upper side, working in the longitudinal slot in the breech-shoe  $c$ .

The front end of the rib  $l$ , on the top of the sleeve  $e$ , is formed into a cam-shaped projection,  $l^2$ .

The said cam-shaped projection  $l^2$  is situated beyond the front end of the sleeve, and, when the gun has been discharged, the said projection projects over the larger part  $b$  of the plug or bolt, as seen in fig. 2.

When it is wished to open the breech to reload the gun, the handle  $d^2$  is raised into a vertical position so as to lift the rib  $d$  from the shoulder  $c^2$  and release the plug  $b$   $b^2$ . In doing this the flat part,  $d^2$ , of the rib  $d$  bears against the cam-shaped projection  $l^2$  on the sliding sleeve  $e$  and forces back the said sleeve, and thereby withdraws the pin or striker  $i$  carried by the said sleeve into a position of safety or within the plug or bolt.

The position of the parts after the handle  $d^2$  has been raised and the plug partly rotated to unlock the said plug is represented in figs. 3 and 4. When the plug has been unlocked, the rib  $d$  of the plug bears against the cam-shaped projection  $l^2$  of the sleeve, and the said rib  $d$  is brought opposite the slot in the breech-shoe  $c$ . The plug may now be moved backward to open the breech, the plug pushing before it the sliding sleeve  $e$ .

After introducing a fresh cartridge into the barrel  $a$  the plug or bolt  $b$   $b^2$  is pushed home to close the breech and the handle  $d^2$  is turned down for locking the said plug or bolt. On pushing home the plug or bolt the gun is cocked in the usual manner, that is, by the sear of the gun engaging with the full-cock bent  $f$  of the sleeve  $e$ , thus arresting the sliding motion of the said sleeve  $e$  and causing the coiled spring  $k$  to be compressed and the pin or striker  $i$  cocked.

In fig. 1 the sleeve is represented in its arrested position and the gun ready to be discharged. After the discharge of the gun the sleeve occupies the position represented in fig. 2. Instead of the cam-shaped projection  $l^2$  on the sleeve being acted upon by the front end  $d^2$  of the rib  $d$  of the plug, the arrangement of parts represented in figs. 9, 10, and 12 may be used, figs. 9 and 10 representing the sleeve separately, and fig. 12 the plug or bolt separately. In this arrange-

ment I make a cam-shaped recess or opening,  $b^2$ , at that part of the bolt or plug  $b$  where the portion of less diameter sets in, and on the front end of the sliding sleeve  $e$  I make a similar shaped projection,  $e^2$ .

When the bolt or plug  $b$   $b^2$  has been locked for firing, the recess  $b^2$  in the bolt is brought into a line with the projection  $e^2$  on the sleeve  $e$ , and on the advance of the said sleeve to carry forward the pin or striker  $i$  to discharge the gun, the projection  $e^2$  enters the recess  $b^2$ , and the said sleeve and bolt are locked or engaged together. On lifting the handle  $d^2$  to unlock the plug, the inclined edge of the cam-shaped recess  $b^2$  in the bolt  $b$ , acting against the inclined edge of the cam-shaped projection  $e^2$  on the sleeve, forces back the said sleeve, and thereby withdraws the pin or striker  $i$  into the plug, so as to be in a safe position should the plug be accidentally driven against the cartridge in the barrel  $a$ . Or, the position of the parts described may be reversed, as illustrated in figs. 11 and 13, fig. 11 representing the sleeve separately, and fig. 13 the plug or bolt separately. In this arrangement the projection marked  $d^2$  is made on the plug  $b$ , and the recess marked  $e^2$  is made on the sleeve  $e$ . Or, instead of the cam-shaped projection in the several arrangements described, a pin or stud on the bolt may be made to act against an incline in the sleeve, or the reverse.

I will now proceed to describe my improvements for preventing the accidental discharge of the gun.

This part of my invention will be best understood by referring to the separate views of the plug and sleeve represented in figs. 3, 5, 14, 15, 16, and 17.

In that part of the rib  $h$  of the sleeve  $e$  at which the half-cock bent  $g$  is situated is a slot,  $m$ , the said slot also passing through the sleeve. In this slot is a safety-catch,  $n$ , consisting of a small lever, the outer end of which, when the catch or lever is in its normal position, projects in front of the half-cock bent  $g$ , as seen in figs. 3 and 5.

At the rear of the part  $b^2$  of the plug or bolt is a slot or opening,  $p$ , of a size proper for the inner end of the safety-catch or lever  $n$  to enter. This slot or opening  $p$  is so situated in the plug that it only comes opposite the safety-catch  $n$  when the said plug has been pushed home and locked in its place by the turning down of the handle  $d^2$ .

On pushing home and locking the plug or bolt  $b$   $b^2$  after the introduction of a cartridge into the barrel  $a$ , the sleeve  $e$  is left behind and the gun is cocked by the sear  $q$  (see fig. 16) engaging in the full-cock bent  $f$ .

In order to prevent the accidental discharge of the gun the sleeve  $e$  is put at half cock, that is, the said sleeve is disengaged from the sear  $q$  and allowed to advance until the said sear enters the half-cock bent  $g$ . In effecting this the nose of the sear  $q$  acts upon the inclined outer end of the safety-catch or lever  $n$ , and raises its inner end, which, entering the opening or recess  $p$  in the part  $b^2$  of the bolt, (which has been brought opposite the said inner end of the catch by the locking of the bolt,) temporarily locks or fastens the sleeve  $e$  and bolt  $b$   $b^2$  together, and prevents the rotation of the bolt. The sleeve  $e$  and pin or striker  $i$ , carried by it, cannot, therefore advance to discharge the gun, and great safety in the gun is thus insured.

When it is wished to discharge the gun the sleeve  $e$  is pulled back until the sear  $q$  engages with the full-cock bent  $f$ . The upper end of the safety-catch or lever  $n$ , on being relieved from the action of the sear  $q$ , passes out of the recess  $p$  in the plug  $b^2$  and releases the sleeve, which can now advance to discharge the gun.

Instead of causing the safety-catch or lever to be put into action by the engaging of the sear with the half-cock bent, the said safety-catch or lever may be raised by a projecting shoulder or stud on the bottom of the breech-shoe, the said shoulder acting against a projection on the under side of the safety-catch or lever. In this arrangement it is desirable to deepen the

groove in the shoe, in which the projecting shoulder or stud is placed, or to prolong the recess or groove or grooves in the end of the part  $b^2$  of the bolt.

In order to secure the pin or striker  $i$  to the sleeve  $e$ , I use a screw-nut,  $s$ , (shown separately in Figure 18,) in place of or in addition to the said cross-pin  $r$ , the said nut  $s$  screwing upon the screw  $r^2$  on the rear end of the pin or striker  $i$ , as represented. A recess is made in the closed end of the sleeve  $e$ , into which the nut  $s$  takes, the said nut lying flush with the closed end of the sleeve, as best seen in figs. 4 and 16.

I will now proceed to describe my improvements for permitting of the escape of gas through the closing-bolt or plug in case imperfect cartridges are fired.

This part of my invention will be best understood by referring to the longitudinal section, fig. 4, and the longitudinal and transverse sections of the bolt, represented separately in Figures 19 and 20.

Near the front end of the bolt  $b$  is a gas-vent or hole,  $t$ , and near the front end of the pin or striker  $i$  is a collar,  $u$ , the said collar working accurately in the hollow of the bolt or plug  $b$ .

When the pin or striker  $i$  is advanced to discharge the gun, as hereinbefore described, the said collar  $u$  covers the gas-vent or hole  $t$ ; but when an imperfect cartridge is fired, the gas from the said imperfect cartridge, entering the hollow of the plug  $b$  through the hole  $v$ , in which the acting end of the pin or striker  $i$  works, forces back the said collar, and thereby uncov-

ers the gas-vent or hole  $t$ , through which hole  $t$  the gas rapidly escapes.

In figs. 1 and 2 the position of the gas-vent or hole  $t$ , when the plug is locked, is readily seen. The pin or striker  $i$  is by this means wholly or mainly relieved from the back action of the gas, and the gun is consequently uninjured by such back action.

Having now described the nature of my invention, and the manner in which the same is to be performed, I wish it to be understood that I do not limit myself to the precise details herein described and illustrated, as the same may be varied without departing from the nature of my invention; but

I claim as my invention of improvements in breech-loading fire-arms of the kind called bolt-guns—

1. The safety-catch or lever for preventing the accidental discharge of the gun, applied to the sliding sleeve and made to lock or engage the sleeve and bolt or plug together, substantially as hereinbefore described and illustrated in the accompanying drawing.

2. The arrangement or combination of parts, substantially as hereinbefore described and illustrated in the accompanying drawing, for permitting of the ready escape of the gas through the closing-bolt or plug, in case imperfect cartridges are fired.

JAMES SMILES. [L. S.]

Witnesses:

GEORGE SHAW, } 7 Cannon Street, Bir-  
RICHARD SKERRETT, } mingham.