

Aug. 16, 1955

E. P. SPAINE

2,715,375

SEWING MACHINE ATTACHMENTS

Filed Jan. 26, 1954

2 Sheets-Sheet 1

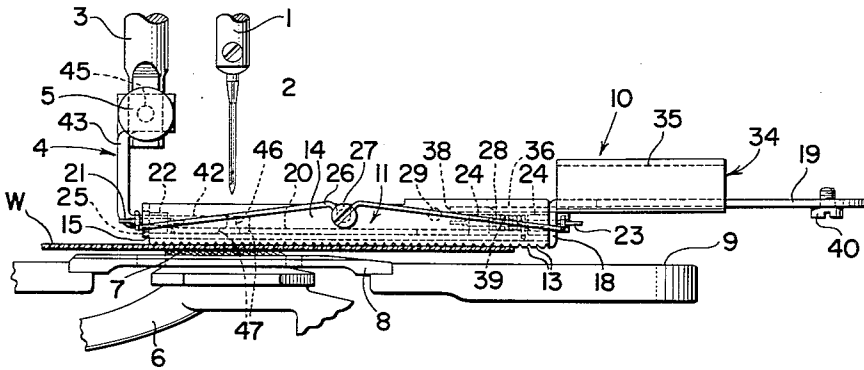

Fig. 1.

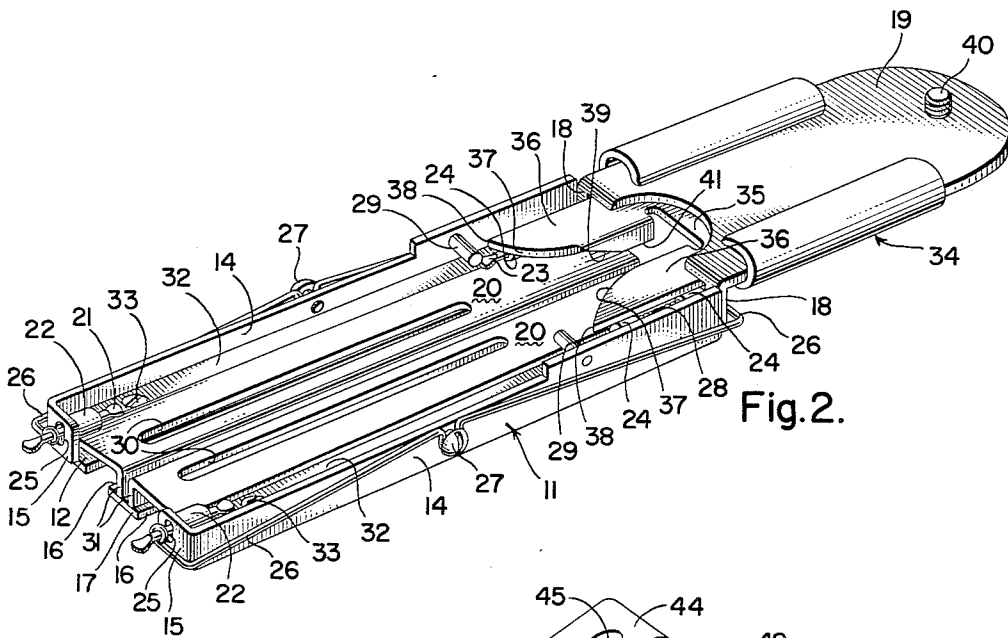

Fig. 2.

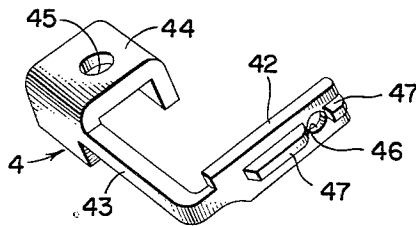

Fig. 3.

WITNESS

Nicholas Leozgala

INVENTOR.

Edward P. Spaine

BY

J. G. Stanford

ATTORNEY

Aug. 16, 1955

E. P. SPAINE

2,715,375

SEWING MACHINE ATTACHMENTS

Filed Jan. 26, 1954

2 Sheets-Sheet 2

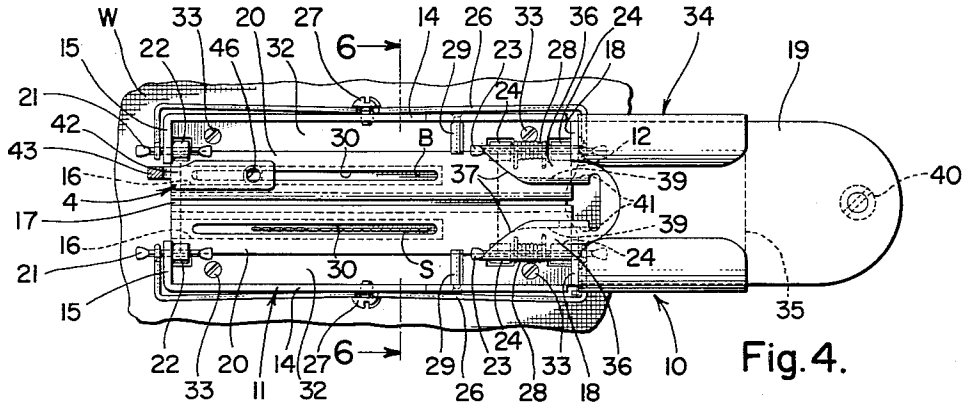

Fig. 4.

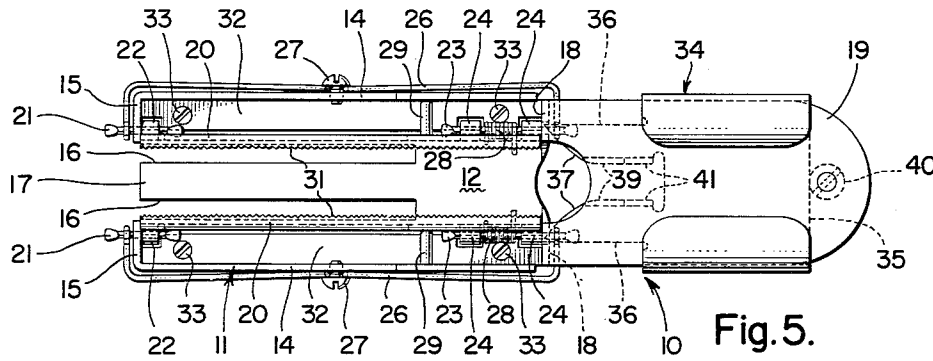

Fig. 5.

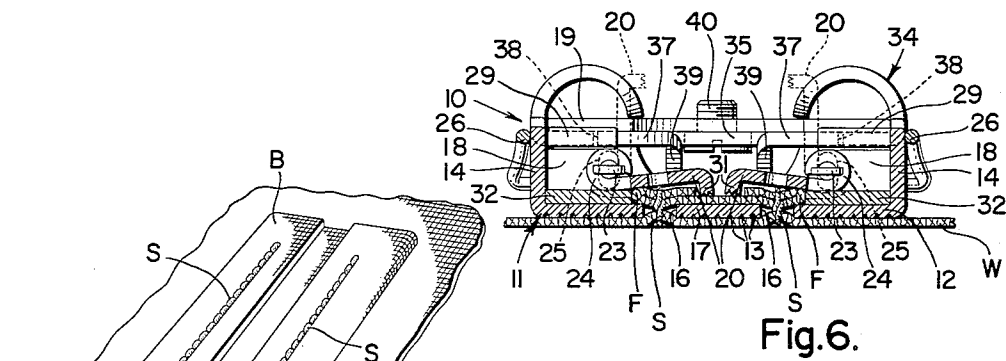

Fig. 6.

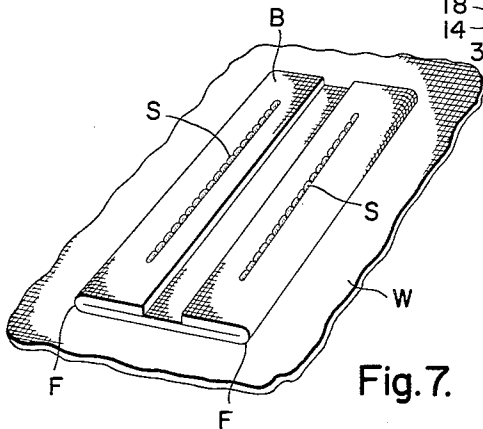

Fig. 7.

WITNESS

Nicholas Leszczynski

INVENTOR.

Edward P. Spaine

BY

J. H. Stanford

ATTORNEY

1

2,715,375

SEWING MACHINE ATTACHMENTS

Edward P. Spaine, Bridgeport, Conn., assignor to The Singer Manufacturing Company, Elizabeth, N. J., a corporation of New Jersey

Application January 26, 1954, Serial No. 406,142

5 Claims. (Cl. 112—136)

The present invention relates to sewing machine attachments and, more particularly, to an attachment that will facilitate fastening a piping strip blank to a body material.

In making piped openings in accordance with the method disclosed in the copending application of Ketterer, Serial No. 397,536, filed December 11, 1953, the folded piping strip blank is stitched to the body material by means of two parallel lines of stitching spaced inwardly a predetermined distance from the fold-edges of the blank. The present invention is directed toward the provision of an attachment for facilitating this step of the method. Reference may be had, if desired, to the above noted Ketterer application for a disclosure of a complete method of making piped openings of which method the step that the present invention is designed to facilitate is only a part. The herein illustrated blank is used in a method that differs from the method disclosed in the Ketterer application only in that a one-piece piping strip blank is used which is cut after it is stitched to the body material.

It is an object of this invention to provide means for use in the stitching of a piping strip blank to a body material that will simplify the operation involved, and which, at the same time, is economical, durable and efficient. Specifically, it is an object to provide such a device which is particularly adapted for use with a single-needle family-type sewing machine to aid in making bound buttonholes and other piped openings, although it is not exclusively limited to such use.

With the above and other objects in view, as will hereinafter appear, the invention comprises the devices, combinations and arrangements of parts hereinafter set forth and illustrated in the accompanying drawings of a preferred embodiment of the invention, from which the several features of the invention and the advantages attained thereby, will be readily understood by those skilled in the art.

Fig. 1 is a fragmentary end elevation view of a sewing machine with an attachment made in accordance with the present invention in position thereon for use.

Fig. 2 is a perspective view of the attachment per se illustrated in Fig. 1.

Fig. 3 is a perspective view of a special presser-foot to be used with the attachment.

Fig. 4 is a top plan view of the attachment per se with the presser-foot of Fig. 3 in operative relation therewith, the upper portion of the presser-foot being sectioned away.

Fig. 5 is a view similar to Fig. 4 but with the clamps in open rather than closed positions.

Fig. 6 is a section view taken substantially on the line 6—6 of Fig. 4, with the open position of the clamps illustrated in dotted lines.

Fig. 7 is a fragmentary perspective view of a piping strip blank stitched to a body garment in the manner contemplated by the present invention.

With reference to the drawings, there is illustrated fragmentary portions of a sewing machine including a vertically reciprocable needle-bar 1 carrying a needle 2 at its

2

lower end, which elements constitute a portion of a stitching mechanism that also includes a loop-taker (not shown) that is adapted to cooperate with the needle in the formation of stitches. There is provided a presser mechanism including the usual presser-bar 3 having a presser-foot 4 releasably secured thereto, as by a screw 5. The feeding mechanism may be of any suitable conventional construction such as of the lower four-motion type and, as herein illustrated, includes a feed-bar 6 carrying feed-dogs 7. The feed-dogs 7 operate in the usual manner through slots in a throat-plate 8 carried by the bed of the machine, which bed has the usual work-supporting surface 9. All of the above elements, with the exception of the specific presser-foot 4, are old and well known and it is not believed necessary to provide further disclosure of the same.

The attachment, which is indicated generally by the numeral 10, has a base-element 11 including a base-plate 12 having the under surface thereof roughened as by cross-hatched grooves 13, see Figs. 1 and 6, or provided with any other suitable friction means to prevent slipping of the same relative to a body material W. Integral with the base-plate 12 are a pair of parallel opposed side walls 14 bent upwardly from the base-plate substantially normal thereto. The ends of the side walls 14 are elongated and bent inwardly toward each other and normal to the respective side wall to form ears 15. The base-plate 12 has formed therein a pair of spaced open-ended slots 16 which are arranged parallel to each other and parallel to the side walls 14 and are formed inwardly from that end of the base-plate 12 adjacent the ears 15. The slots are spaced apart a distance equal to the desired spacing of the two lines of stitching in the finished product as seen in Fig. 7. That portion of the base-plate 12 between the slots 16 constitutes a tongue 17.

At the end opposite the ears 15, there is bent upwardly from the base-plate 12 an integral end wall 18 arranged substantially normal to the base-plate and the side walls 14. From the upper end of the end wall 18 is bent an integral slide-plate 19 arranged substantially parallel to the base-plate 12 but extending in a direction from the end wall 18 opposite to that of the base-plate.

There are provided clamping means for holding a piping strip blank in the desired position on the base-plate 12, said means comprising a pair of clamps 20 arranged parallel to the side walls 14 and pivotally mounted to the base-element 11 outwardly of the slots 16 and upon that face opposite the friction means 13. The pivotal mounting for the clamps 20 preferably includes pivot pins 21 passing through lugs 22 upstanding from one end of each of the clamps 20 and through the ears 15, and pivot pins 23 passing through a pair of spaced lugs 24 upstanding from the other end of each of the clamps 20 and through the end wall 18. The apertures in the ears 15 and end wall 18 through which the pivot pins 21 and 23 extend, as best illustrated in Fig. 2 in which the apertures 25 in the ears 15 are clearly visible, are vertically elongated to provide a floating pivot for reasons hereinafter explained. The pivot pins 21 and 23 are urged downwardly to the bottom of their respective apertures by springs 26 which, at their ends, are formed to encircle the pivot pins and which, at their midpoints, are clamped to the respective side wall 14 by screws 27. Springs 28 are coiled about the pivot pins 23 between the spaced lugs 24 for biasing the clamps 20 to open position as illustrated in Fig. 5. Stops 29 are provided for limiting the motion of the clamps 20 under the action of the springs 28. The clamps 20 are provided with needle slots 30 which register vertically with the slots 16 in the base-plate 12 and the free edges of the clamps are turned downwardly to form flanges 31. Edge-guiding strips 32 are positioned on the base-plate 12 along each of the side walls 14, and are secured therein by screws 33.

Opening and closing of the clamps 20 may be readily effected by means of a slide 34 formed of sheet material and including a body portion 35 underlying the slide-plate 19 of the base-element. The marginal edges of the body-portion are doubled over to loosely embrace the corresponding edges of the slide-plate or, in other words, wrapped around the slide-plate, whereby the same is held thereon for sliding movement. A pair of arms 36 extend forwardly in the direction of closing motion from the body-portion of the slide, and the end-wall 18 and slide-plate 19 of the base element 11 are appropriately broken away to permit movement of the arms to positions overlying the respective one of the clamps 20. Each of the arms 36 is formed with a first cam surface 37 which is arranged horizontally and presents a point 38 that, when the respective clamp is opened to its stop position, is outwardly of the same. Thus, as the slide 34 is moved toward the clamps 20, the first cam surfaces 37 of the arms 36 will tend to pivot the clamps toward their closed position. Each of the arms 36 is also formed with a second cam surface 39 which is arranged vertically and forms a smooth continuation of the cam surface 37. It will be apparent that the two cam surfaces acting sequentially will effect a swinging of the clamps 20 from a vertical or open position to a horizontal or closed position as the slide is manually moved toward the clamps. A screw 40 is provided which will prevent the slide 34 from being withdrawn completely from the slide-plate 19. The rear portion 41 of the cam surface 39, as best seen in Fig. 2, is flat and serves to hold the clamps in closed position.

The present attachment is used in stitching a folded piping strip blank B to a body material W by means of two parallel lines of stitches, as illustrated in Fig. 7. It will be noted that the fold edges F of the blank are parallel and the lines of stitches are each parallel to and spaced inwardly from one of the fold edges, and pass through the blank B, the folded edge thereof and the body material W. As hereinbefore pointed out, this step is one in the method of making a bound buttonhole as disclosed in the copending application of Ketterer. The piping strip blanks B are relatively small rectangular pieces of goods. To load a blank B into the attachment 10, the attachment is opened as illustrated in Fig. 5 and in dotted lines in Fig. 6, and the blank is laid into the U-shaped area defined by the base-plate 12 and upstanding clamps 20. The blank is of such size that when properly positioned in the opened attachment it will assume a U-shaped configuration with the central portion thereof lying along the upper surface of the base-plate 12 and overlying the tongue 17, and the edge portions lying upwardly along the inner surfaces of the clamps 20. As the clamps are closed, by moving the slide 34 toward the same, the upstanding edge portions of the blank are folded inwardly. It is, of course, critical that the lines of stitches S securing the blank to the body material be spaced a predetermined distance from the fold edges F. To insure the proper spacing of the fold-edges and the lines of stitching, the fold-edges F are placed along the inner edges of the edge-guiding strips 32. The flanges 31 engage the edges of the blank and prevent its sliding out as the clamps are closed, and also aid in forcing the fold-edges into engagement with the edge of the strips 32. When the clamps are completely closed, further movement of the slide 34 will force the flat rear portion 41 of the cam surface 39 over the same which will hold the clamps closed until manually released. The floating pivots for the clamps 20 permit use of piping strip blanks of different materials of varying thicknesses. When the blank is properly loaded and the clamps locked in closed position by the slide 34, the attachment is ready to be placed in stitching position on the machine.

The presser-foot 4, which is illustrated per se in Fig. 3, comprises a sole-plate 42, a shank 43 and a U-shaped attaching section 44 adapted to encircle the lower end of

the presser-bar 3 and having an aperture 45 formed therein for receiving the attaching screw 5. The sole-plate 42 is relatively small and rectangular, and is provided with a needle-aperture 46 and on the sole-face or underside with ribs 47 which are aligned with the needle-aperture 46. The ribs 47 are made of substantially the same width as the slots 30 in the clamps 20 and are only as high as the thickness of the clamps 20, whereby the ribs will fit into the slots 30 and will act to guide the attachment 10 relative to the point of needle penetration.

With the attachment 10 loaded with a blank B and the clamps 20 locked closed by the slide 34, it is inserted under the presser-foot 4 which is raised in the usual manner. The work W, which is placed under the presser-foot beneath the attachment is first aligned with respect to the desired position of the seam lines. The attachment is aligned with respect to the work W and with respect to the presser-foot 4 so that the rib 47 will be seated in the end of one of the slots 30 in the clamps 20, as illustrated in Fig. 4, and when so aligned, the presser-foot is lowered. When the machine is operated in the normal manner, the needle will pass through the needle aperture 46 in the sole-plate 42, the needle-slot 30 in the selected one of the clamps 20, the corresponding slot 16 in the base-plate 12, the work W, the blank B, and the folded-over edge-portion of the blank B. The body material W, the attachment 10, and the blank B are fed past the stitching mechanism by the usual feeding mechanism of the machine, which, as illustrated, includes the feed-dogs 7. The feed-dogs 7 act against body material W and, as hereinbefore mentioned, the attachment 10 is roughened by the cross-hatched grooves 13 to prevent sliding of the same relative to the body material. The rib 47 sliding in the selected slot 30 acts to guide the attachment. When the end of the first line of stitching S is reached, the machine is stopped, the presser-foot is lifted, the attachment is shifted so that the rib 47 will be seated in the beginning end of the second slot 30, the presser-foot is lowered, and the machine again operated to produce the second line of stitching S. The blank B is now stitched to the body material. It will be apparent that the tongue 17 of the base-plate 12 lies between the blank B, the body-material W and the two lines of stitches. However, it may be readily removed by virtue of the fact that the slots 16 have open ends.

While a single needle machine is herein illustrated, it will be obvious that a two-needle machine could be used to sew both lines of stitches S simultaneously.

Having thus described the nature of the invention, what I claim herein is:

1. An attachment for use with a sewing machine in stitching to a body material a piping strip blank having a pair of opposed edges folded inwardly on one face of the blank along spaced parallel lines, the blank being secured to the body material by two lines of stitching arranged parallel to the fold-edges, one line of stitching being spaced inwardly a predetermined distance from each of the fold-edges and each line of stitching passing through the respective folded portion of the blank and the body material, said attachment comprising a base-plate having a pair of parallel open-ended needle slots therein spaced apart a distance equal to the desired spacing of the lines of stitching, friction means upon one face of said base-plate to inhibit sliding of the body material relative thereto, means for clamping a folded piping strip blank against the other face of the base-plate with the fold-edges thereof arranged parallel to and outwardly of the slots in the base-plate, said clamping means having a pair of needle slots therein registering with the slots in the base-plate, and releasable means for holding said clamping means in clamping relation with said base-plate.

2. An attachment for use with a sewing machine in stitching to a body material a piping strip blank having

a pair of opposed edges folded inwardly on one face of the blank along spaced parallel lines, the blank being secured to the body material by two lines of stitching arranged parallel to the fold-edges, one line of stitching being spaced inwardly a predetermined distance from each of the fold-edges and each line of stitching passing through the respective folded portion of the blank and the body material, said attachment comprising a base-plate having a pair of parallel open-ended needle slots therein spaced apart a distance equal to the desired spacing of the lines of stitching, a pair of clamps pivotally mounted to one face of said base-plate on axes parallel to said slots outwardly thereof, each of said clamps being adapted to be sprung from an open position to a closed position overlying the respective adjacent slot, and each of said clamps having a needle slot therein which when in closed position registers with the respective slot in the base-plate.

3. An attachment for use with a sewing machine in stitching to a body material a piping strip blank having a pair of opposed edges folded inwardly on one face of the blank along spaced parallel lines, the blank being secured to the body material by two lines of stitching arranged parallel to the fold-edges, one line of stitching being spaced inwardly a predetermined distance from each of the fold-edges and each line of stitching passing through the respective folded portion of the blank and the body material, said attachment comprising a base-plate having a pair of parallel open-ended needle slots therein spaced apart a distance equal to the desired spacing of the lines of stitching, a pair of clamps pivotally mounted to one face of said base-plate on axes parallel to said slots and arranged upon opposite sides of said slots outwardly thereof, each of said clamps being adapted to be swung from an open position to a closed position overlying the respective adjacent slot, and each of said clamps having a needle slot therein which when in closed position registers with the respective slot in the base-plate, spring means for biasing said clamps to open position about the pivot axes thereof, and means for maintaining said clamps in closed position.

4. An attachment for use with a sewing machine in stitching to a body material a piping strip blank having a pair of opposed edges folded inwardly on one face of the blank along spaced parallel lines, the blank being secured to the body material by two lines of stitching arranged parallel to the fold-edges, one line of stitching being spaced inwardly a predetermined distance from each of the fold-edges and each line of stitching passing through the respective folded portion of the blank and the body material, said attachment comprising a base-plate having a pair of parallel open-ended needle slots therein spaced apart a distance equal to the desired spacing of the lines of stitching, a pair of clamps pivotally mounted to one

face of said base-plate on axes parallel to said slots and arranged upon opposite sides of said slots outwardly thereof, each of said clamps being adapted to be swung from an open position to a closed position overlying the respective adjacent slot, and each of said clamps having a needle slot therein which when in closed position registers with the respective slot in the base-plate, spring means for biasing said clamps to open position about the pivot axes thereof, means for limiting the opening movement of said clamps to a normal open position, and means for moving said clamps to and maintaining the same in closed position comprising a slide mounted on said base-plate for sliding movement in a direction parallel to the pivot axes of said clamps, a pair of arms extending from said slide in the direction of motion, and a cam face formed on each of said arms, said cam faces being shaped to initially contact said clamps outwardly of the pivots thereof when in normal open position and to urge the same toward closed position upon movement of the slide toward the clamps.

5. In a sewing machine having a frame including a work-supporting surface and a bracket-arm terminating in a head overhanging said work-supporting surface, stitching mechanism including a reciprocatory needle carried by said head, feeding mechanism including a feed-dog located beneath and operable through said work-supporting surface to effect feeding of the work, and presser mechanism including a presser-bar carried by said head for sliding movement toward and from said work-supporting surface, an attachment for use in stitching folded piping strip blanks to a body material with a pair of parallel lines of stitching, said attachment comprising a base-plate adapted to overlie a body material, said base-plate having a pair of parallel open-ended needle slots therein spaced apart a distance equal to the desired spacing of the lines of stitching, clamping means for clamping a folded piping strip blank to the upper face of the base-plate with the fold-edges thereof arranged parallel to and outwardly of the slots in the base-plate, said clamping means having a pair of needle slots therein registering with the slots in the base-plate, and releasable means for holding said clamping means in clamping relation with said base-plate, and means for guiding said attachment as it is moved across said work-supporting surface by said feeding means comprising a presser-foot secured to the lower end of said presser-bar, and a ridge on the work-engaging face of the presser-foot adapted to be received in the needle-slots in said clamping means.

References Cited in the file of this patent

UNITED STATES PATENTS
 2,573,359 Rich ----- Oct. 30, 1951