



(19) **United States**
(12) **Patent Application Publication**
Dalum et al.

(10) **Pub. No.: US 2012/0207620 A1**
(43) **Pub. Date: Aug. 16, 2012**

(54) **HYBRID VEHICLE DRIVE SYSTEM AND METHOD AND IDLE REDUCTION SYSTEM AND METHOD**

60/959,181, filed on Jul. 12, 2007, provisional application No. 61/126,118, filed on May 1, 2008.

Publication Classification

(75) Inventors: **Joseph Thomas Dalum**, Delafield, WI (US); **Joseph Mario Ambrosio**, Smithtown, NY (US)

(51) **Int. Cl.**
F04B 49/06 (2006.01)

(73) Assignee: **Odyne Systems, LLC.**

(52) **U.S. Cl.** **417/44.1; 180/65.275; 903/903**

(21) Appl. No.: **13/397,561**

(57) **ABSTRACT**

(22) Filed: **Feb. 15, 2012**

Related U.S. Application Data

(63) Continuation-in-part of application No. 12/130,888, filed on May 30, 2008, Continuation-in-part of application No. 12/217,407, filed on Jul. 3, 2008.

(60) Provisional application No. 60/979,755, filed on Oct. 12, 2007, provisional application No. 61/014,406, filed on Dec. 17, 2007, provisional application No.

One embodiment relates to a hybrid vehicle drive system for a vehicle including a first prime mover, a first prime mover driven transmission, a rechargeable power source, and a PTO. The hybrid vehicle drive system further includes a hydraulic motor in direct or indirect mechanical communication with the PTO and an electric motor in direct or indirect mechanical communication with the hydraulic motor. The electric motor can provide power to the prime mover driven transmission and receive power from the prime mover driven transmission through the PTO. The hydraulic motor can provide power to the prime mover driven transmission and receive power from the prime mover driven transmission through the PTO.

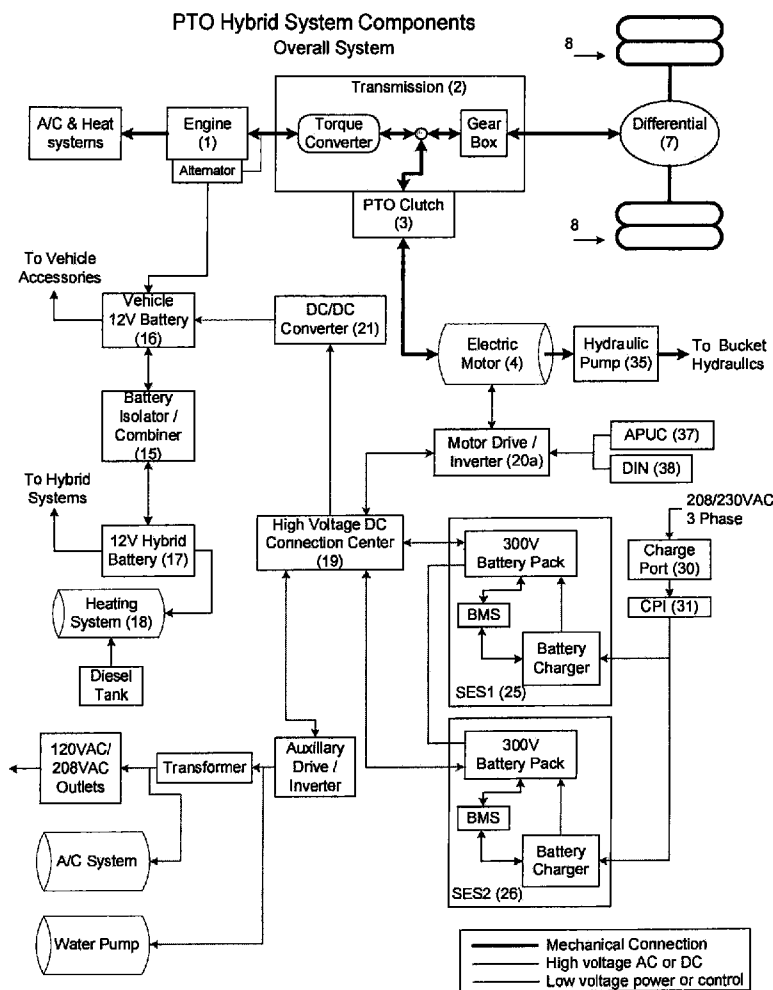

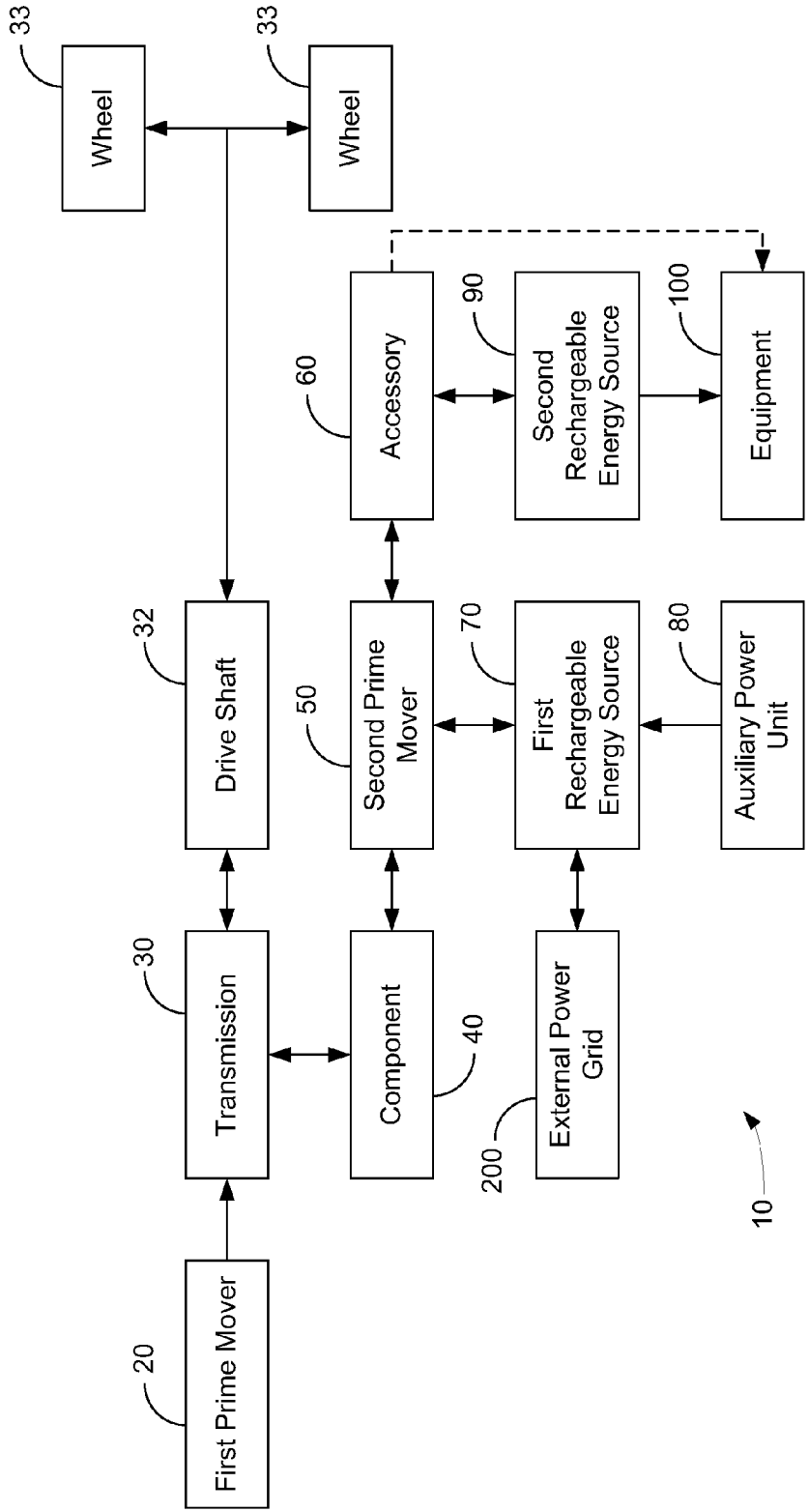

FIG. 1

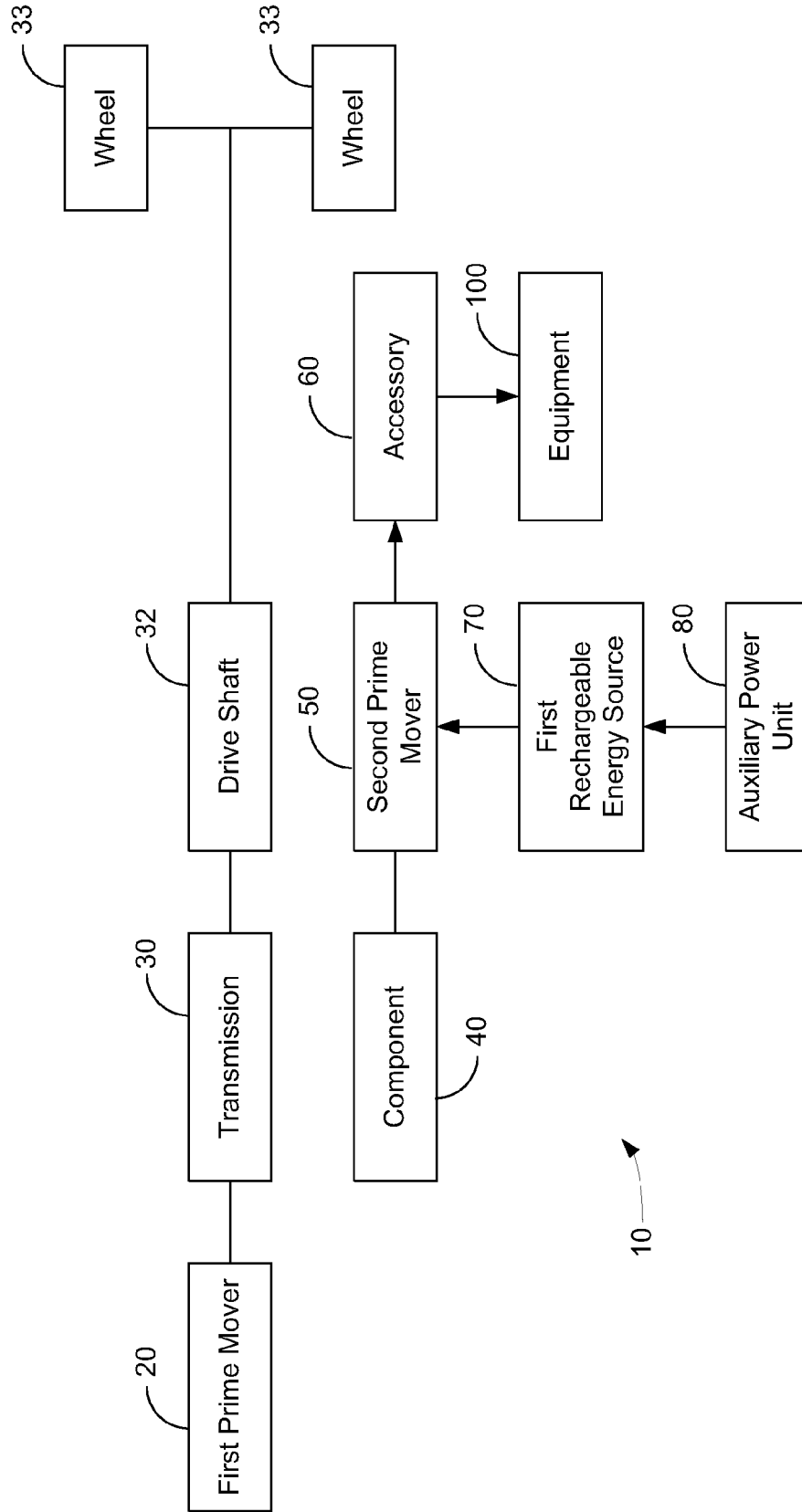

FIG. 2

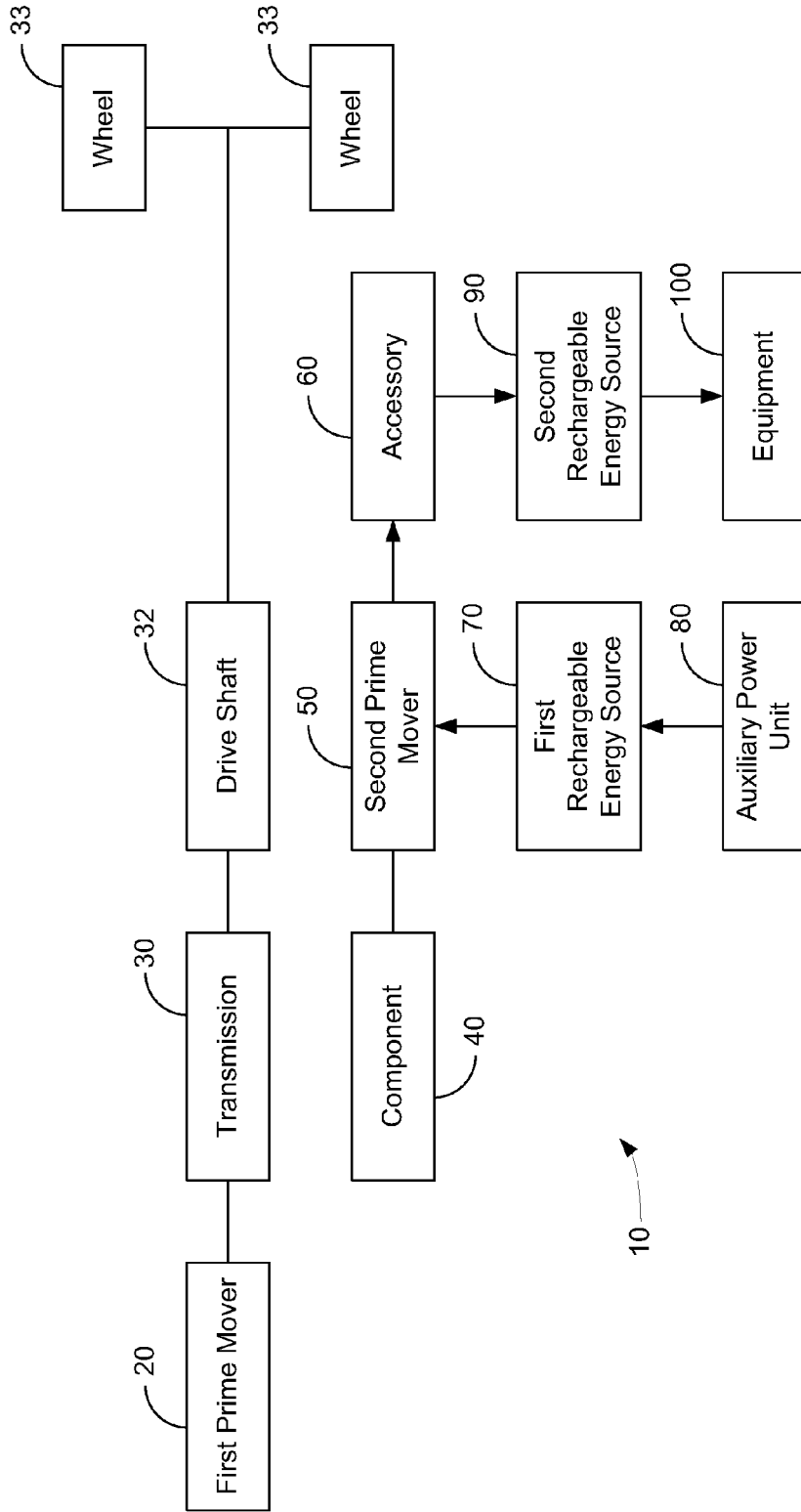

FIG. 3

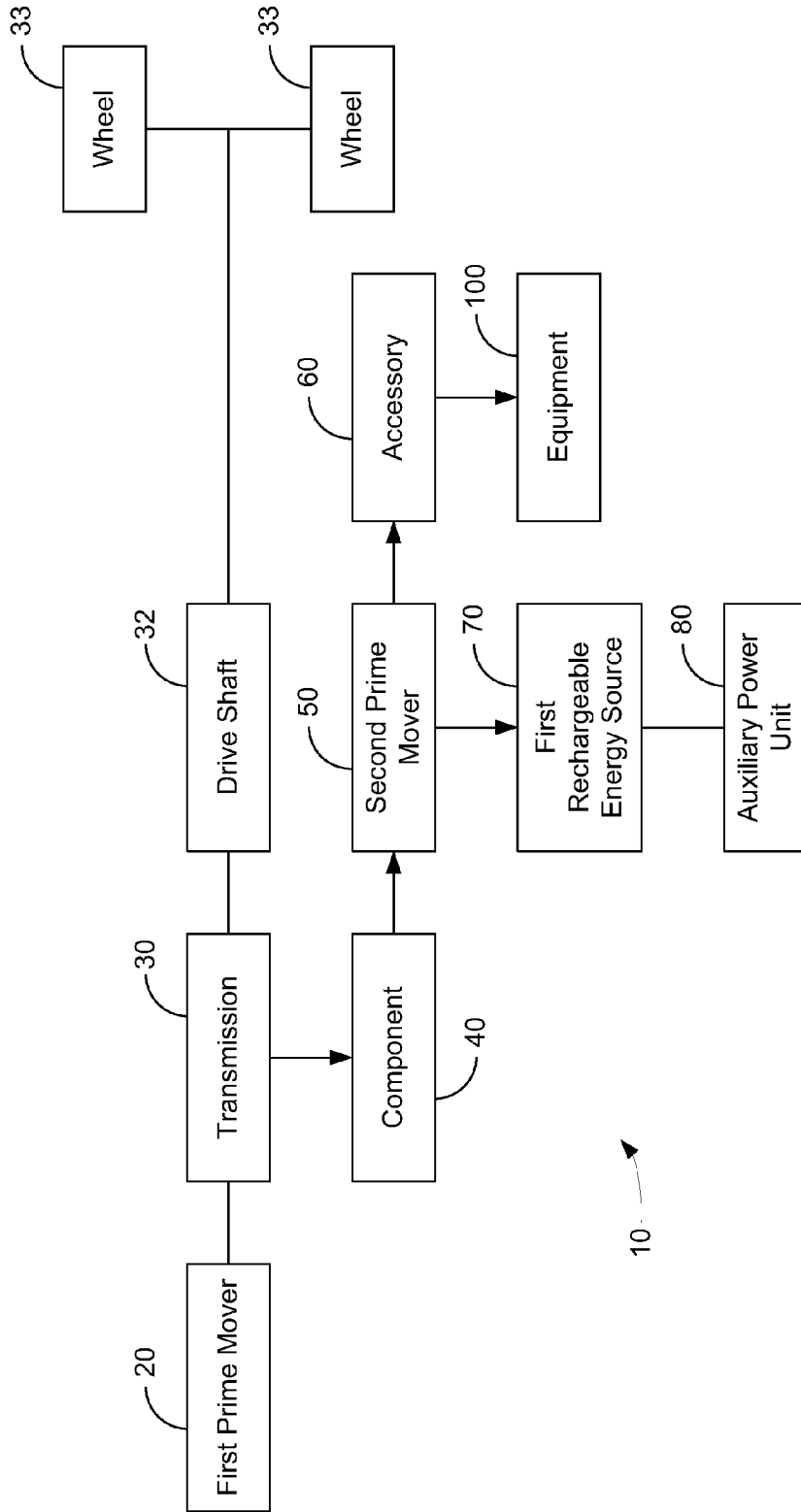

FIG. 4

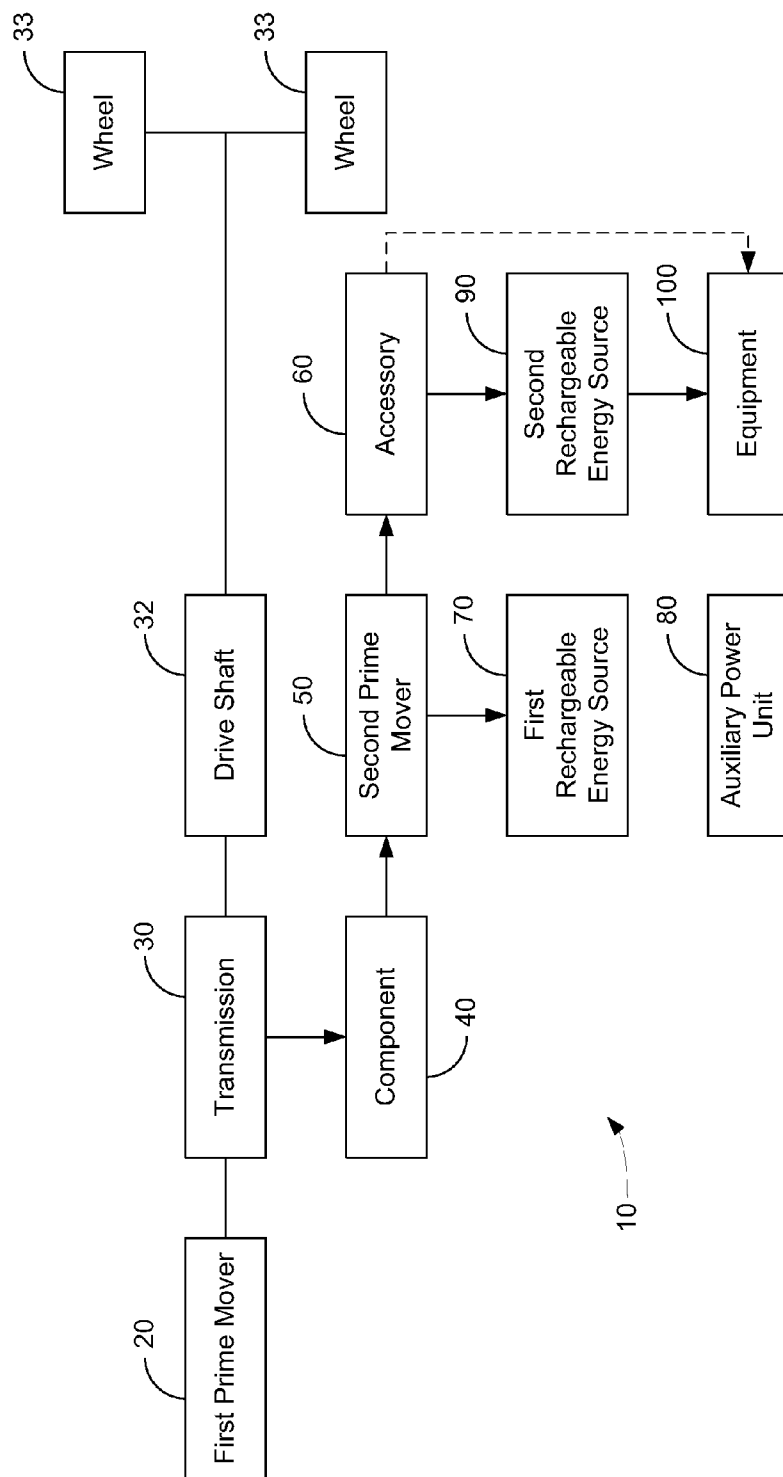

FIG. 5

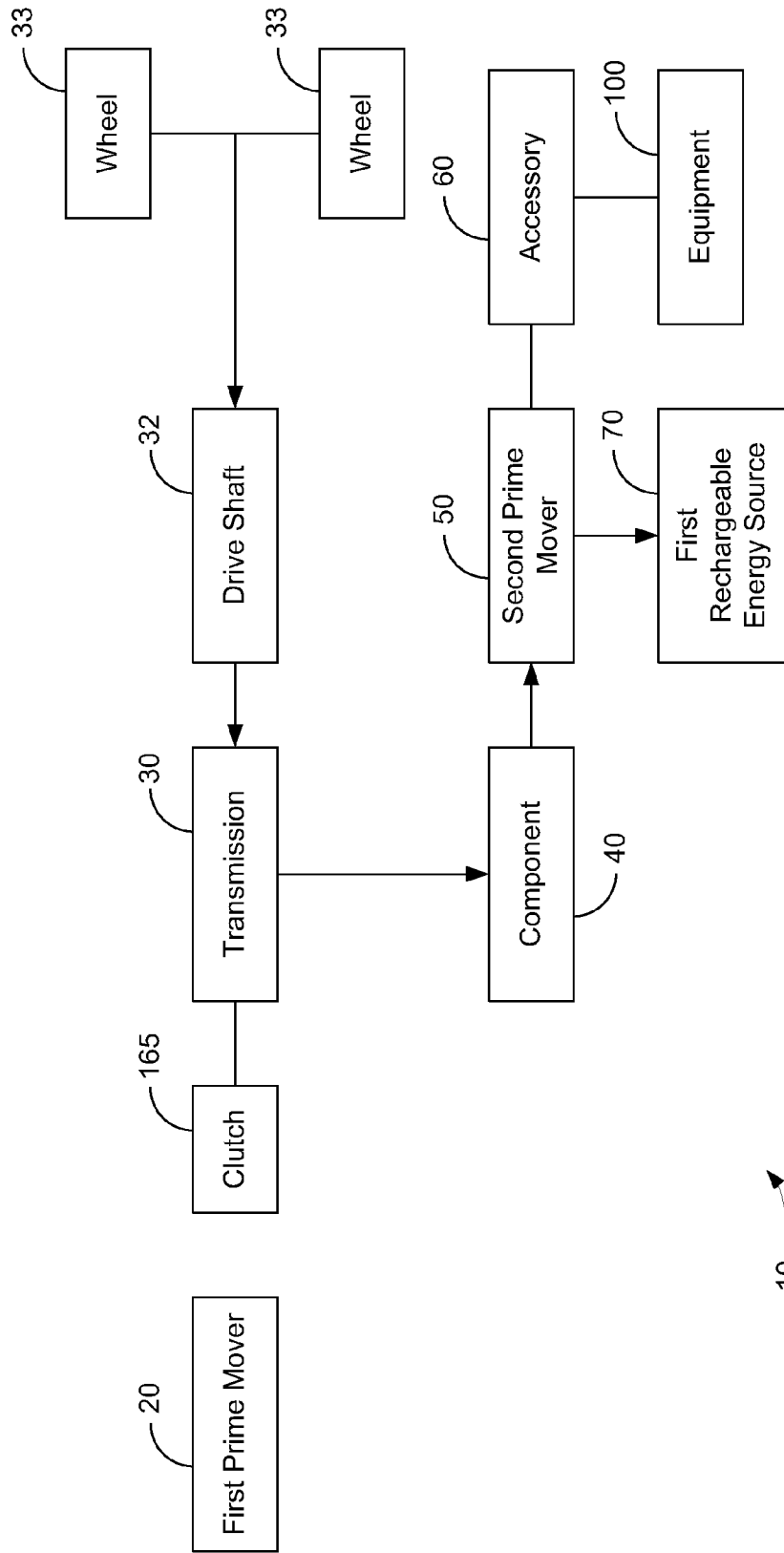

FIG. 6

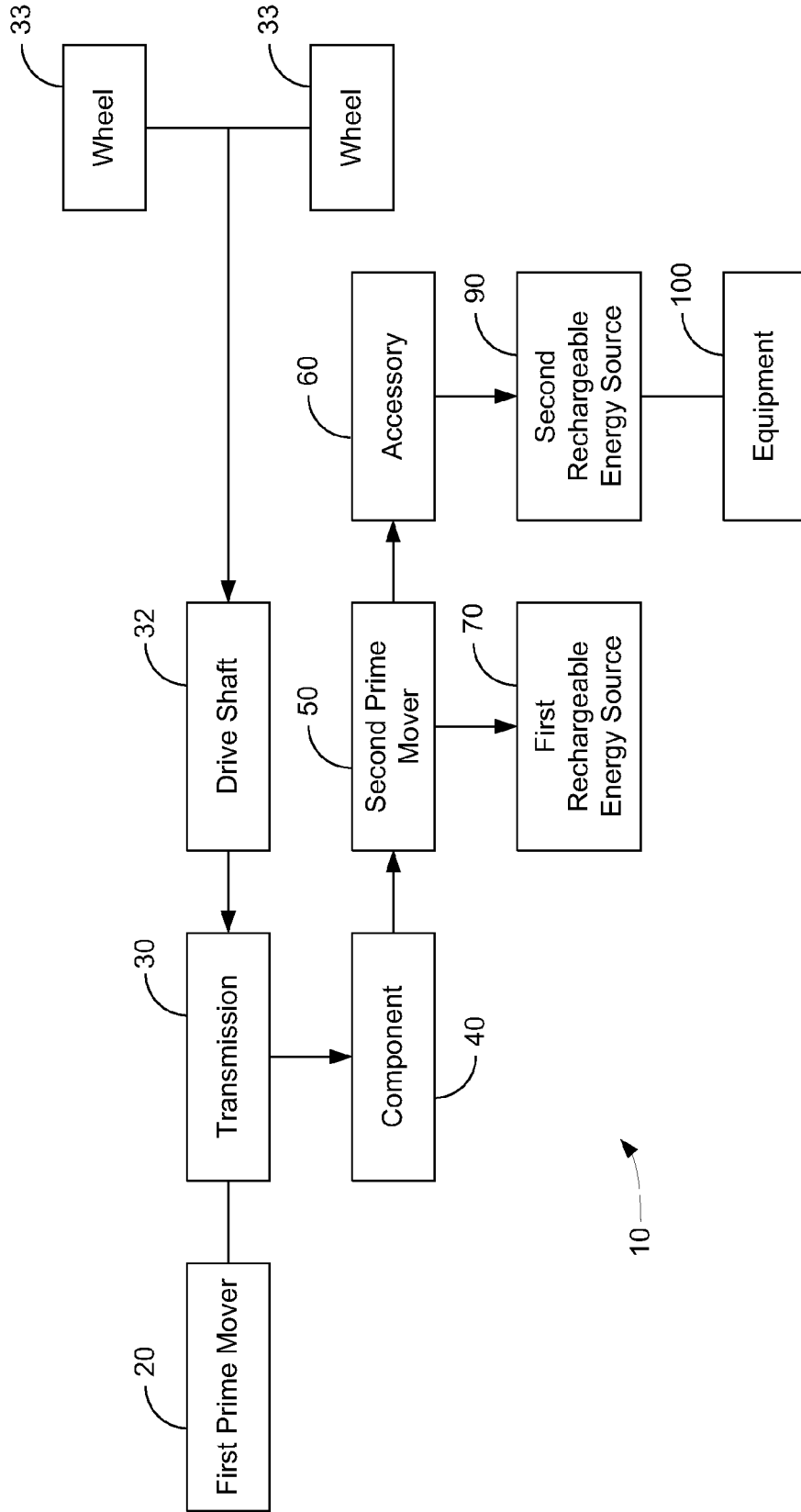

FIG. 7

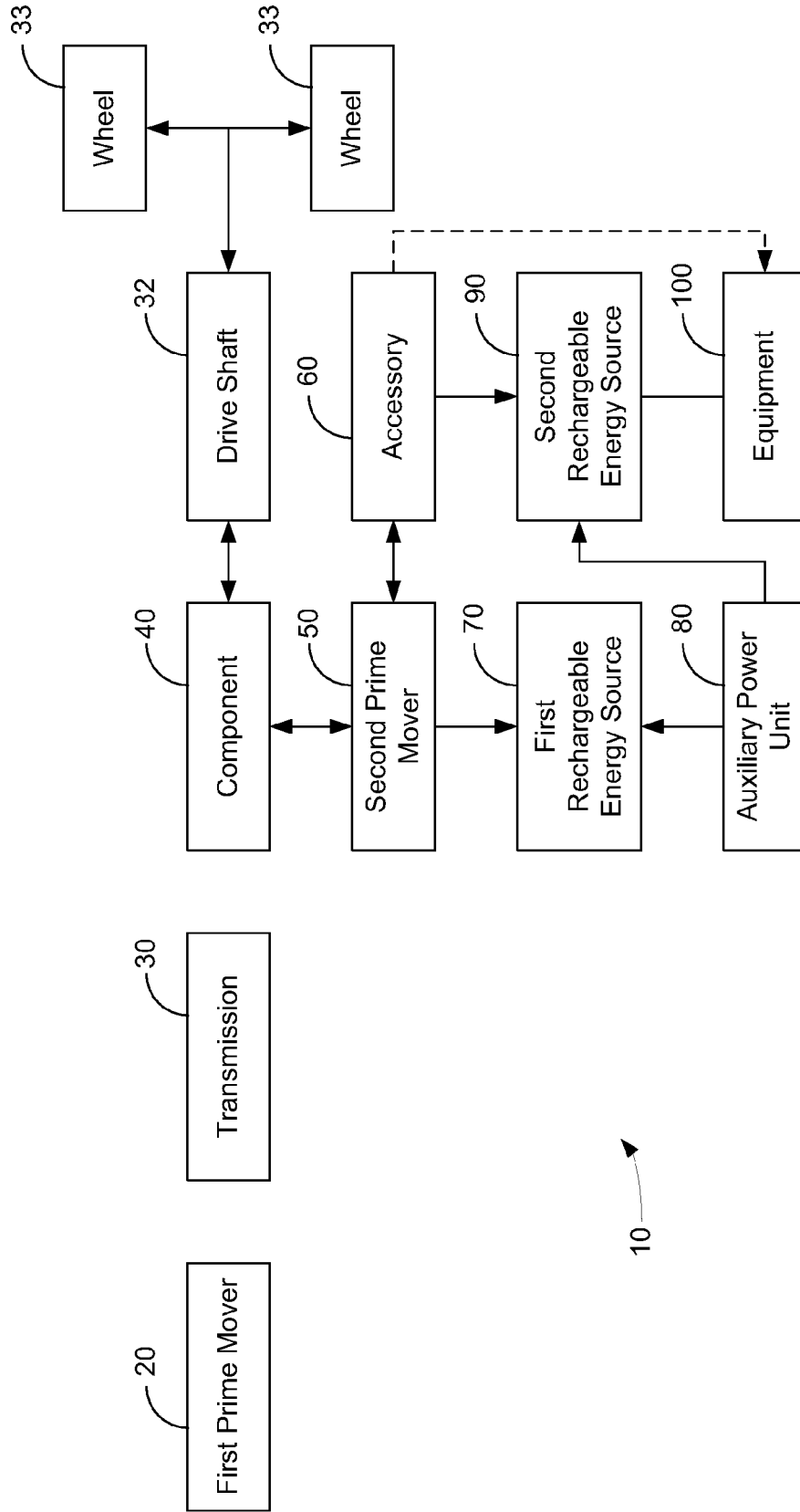

FIG. 8

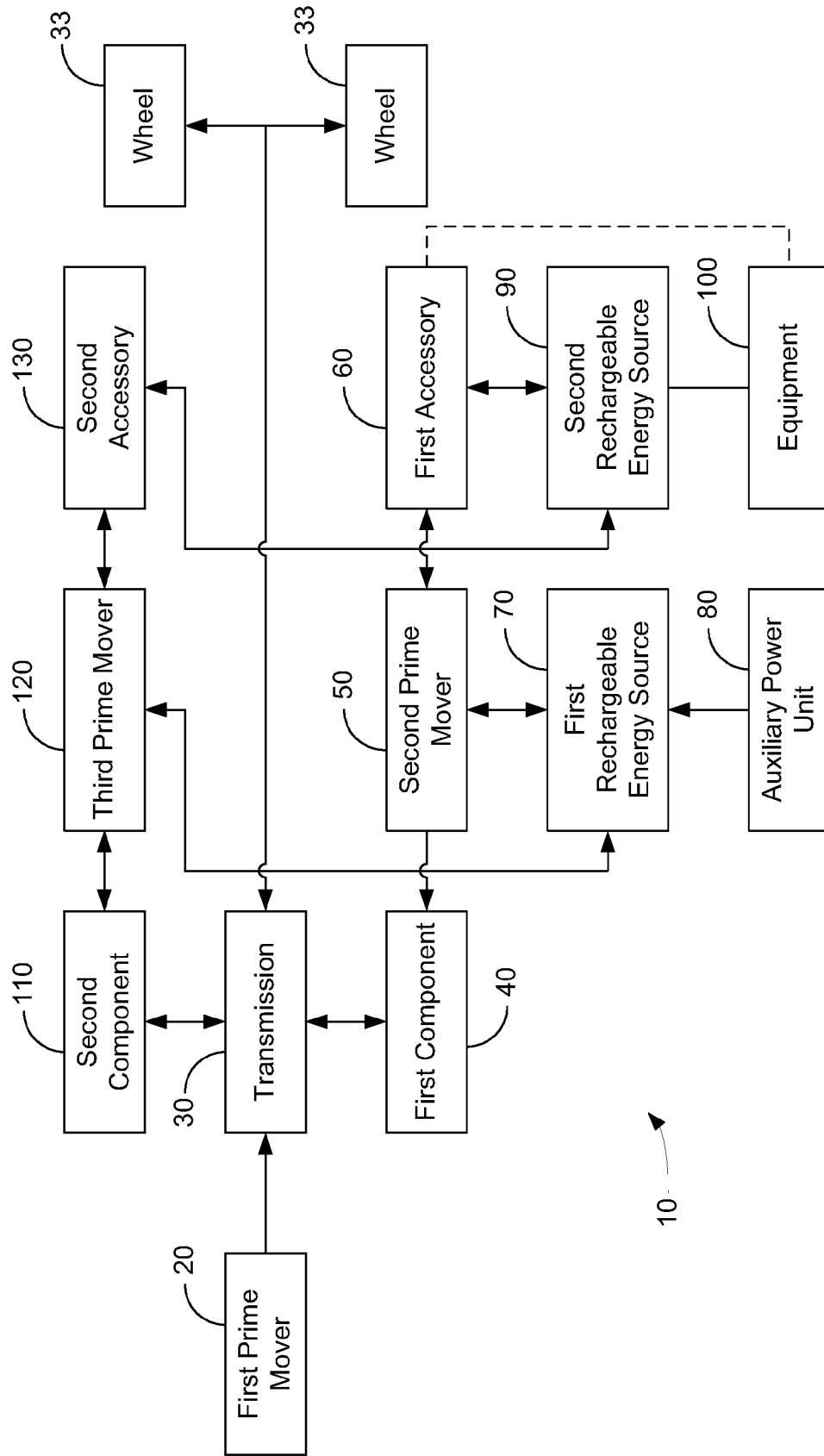

FIG. 9

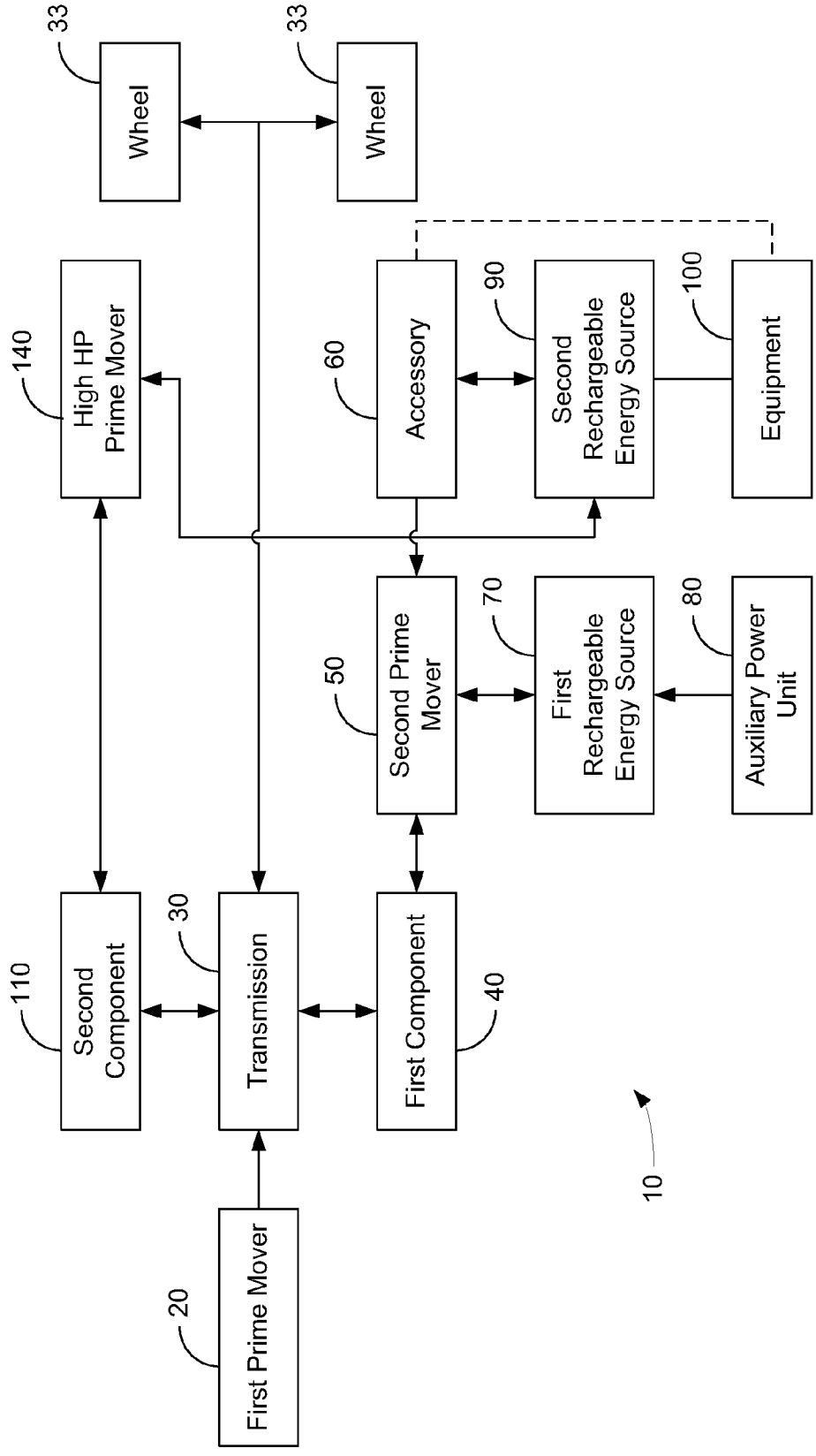

FIG. 10

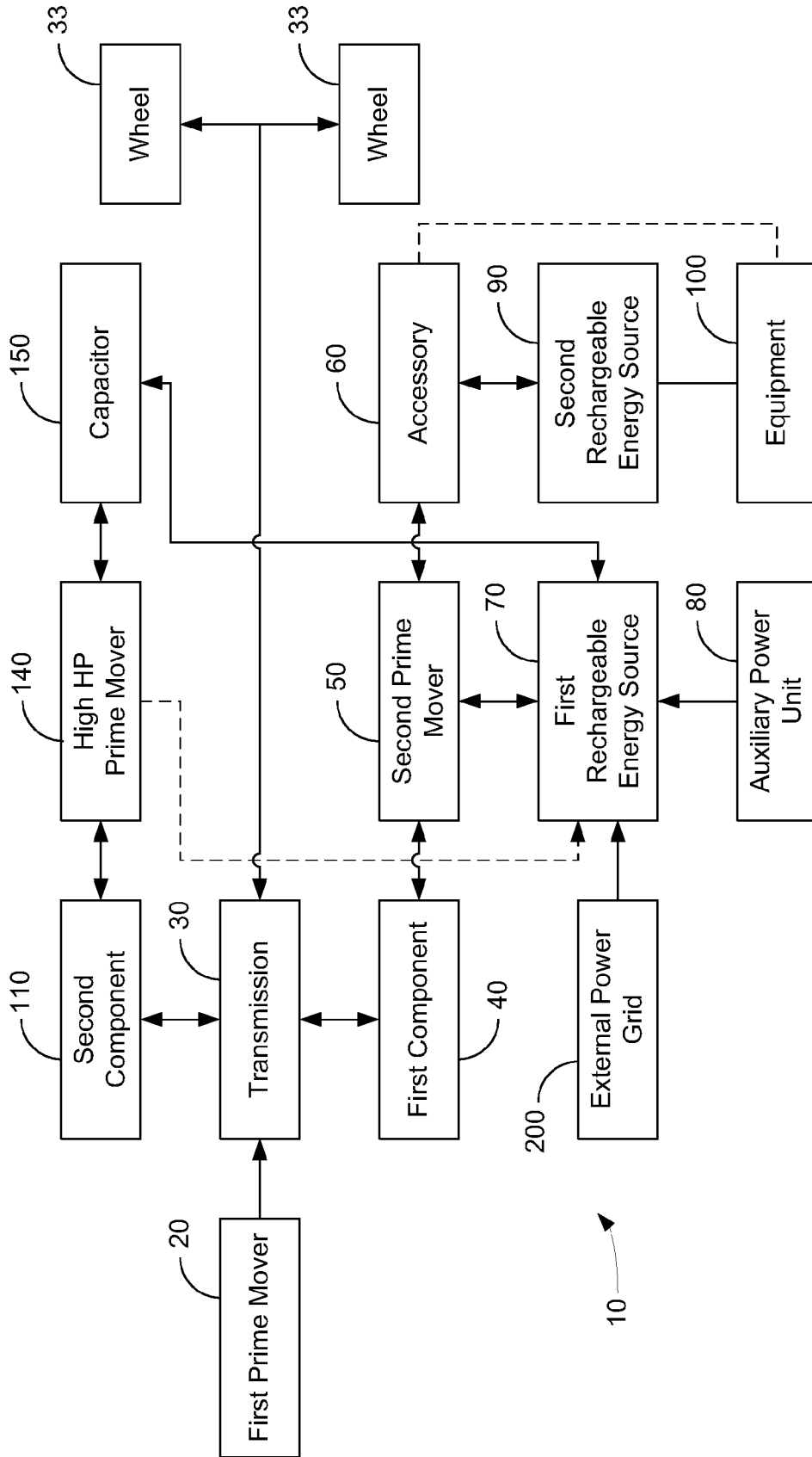

FIG. 11

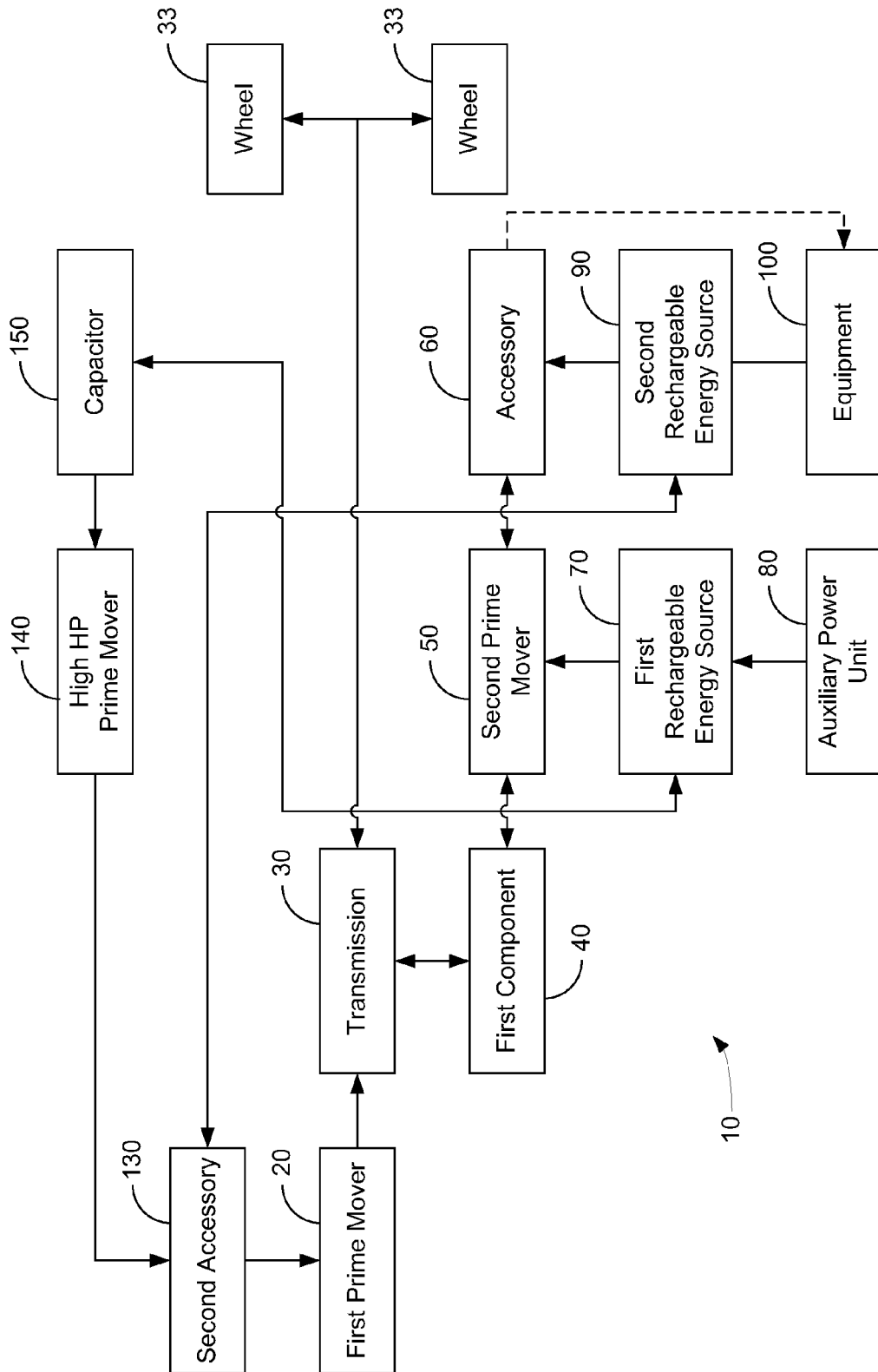

FIG. 12

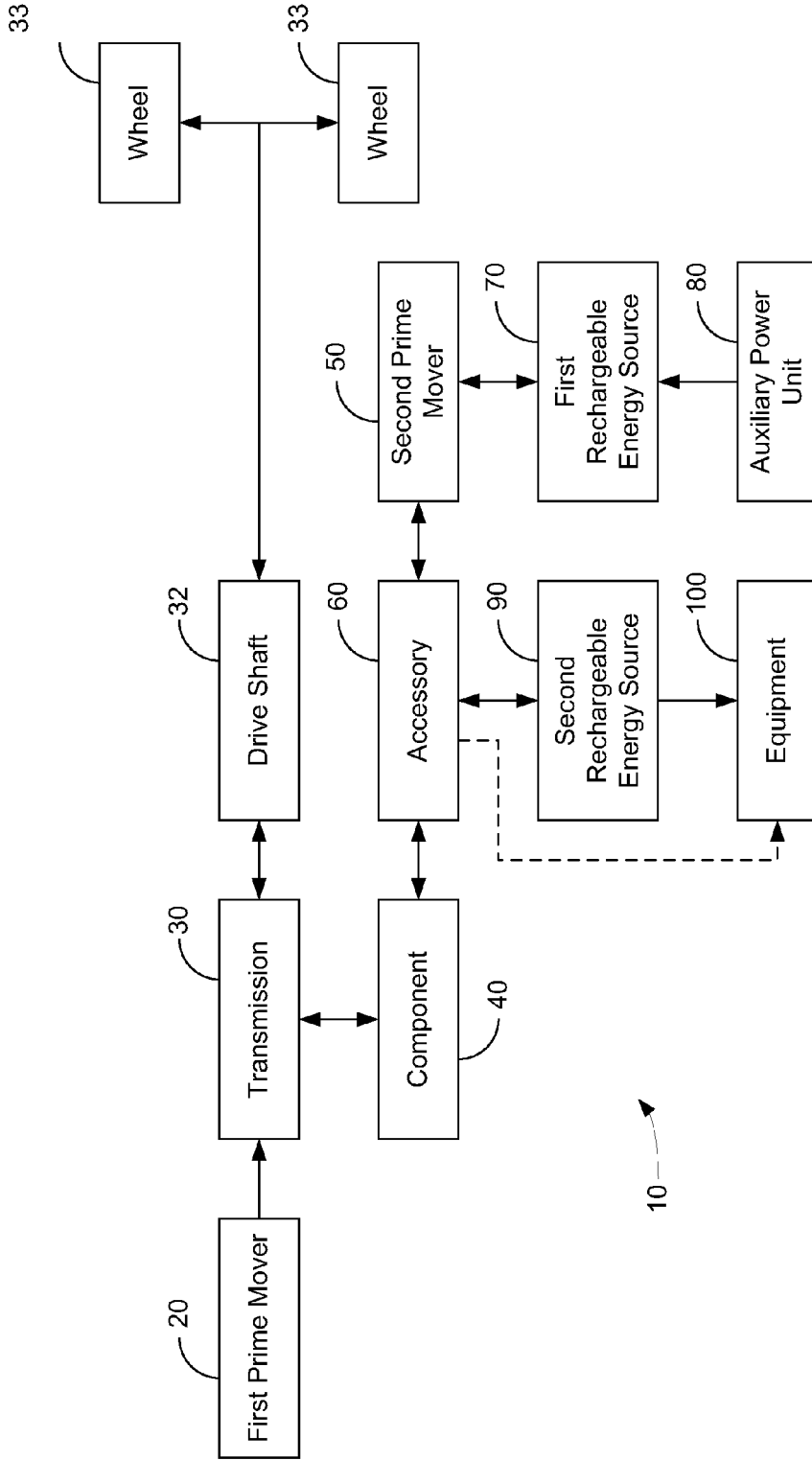

FIG. 13

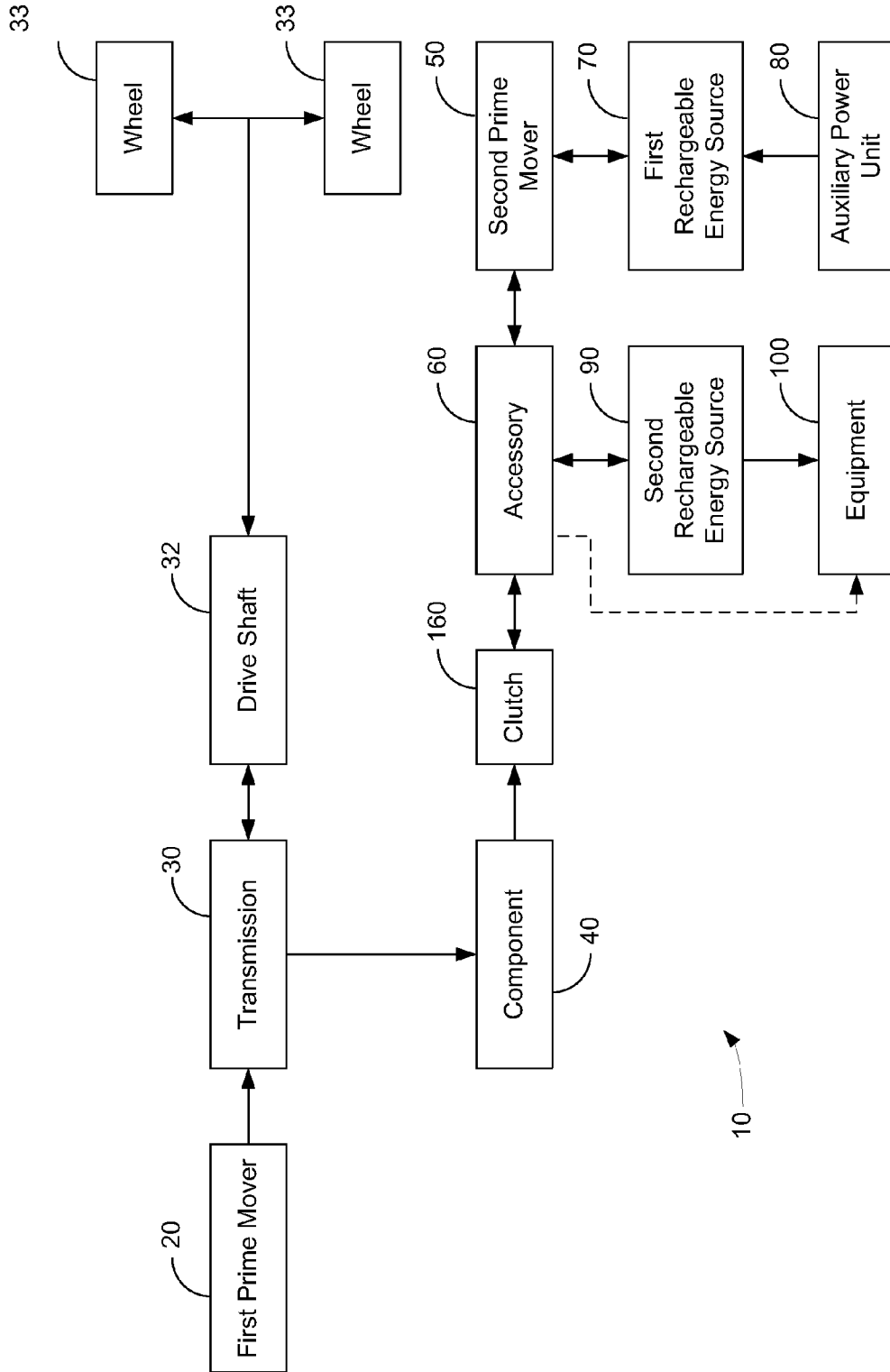

FIG. 14

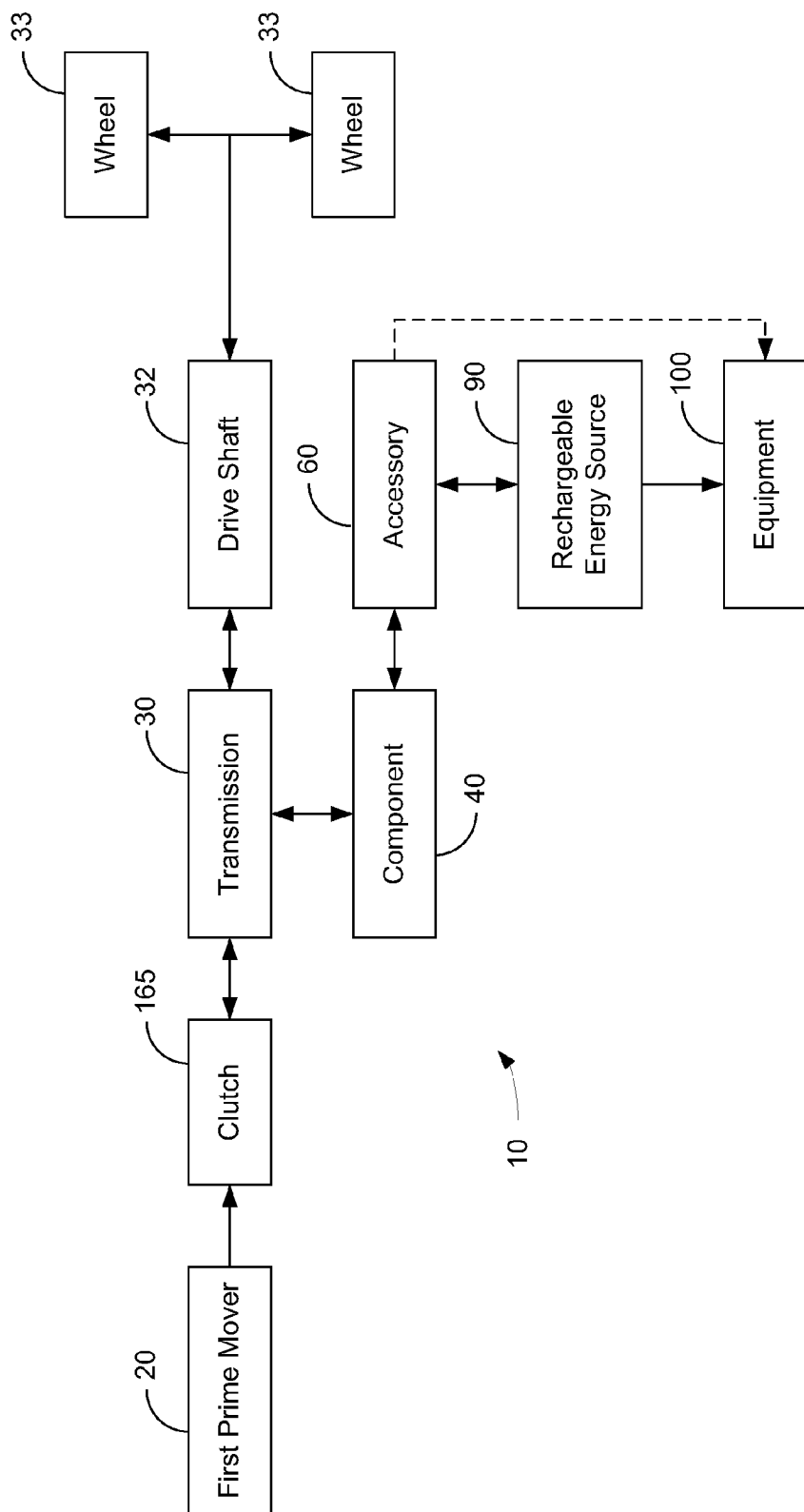

FIG. 15

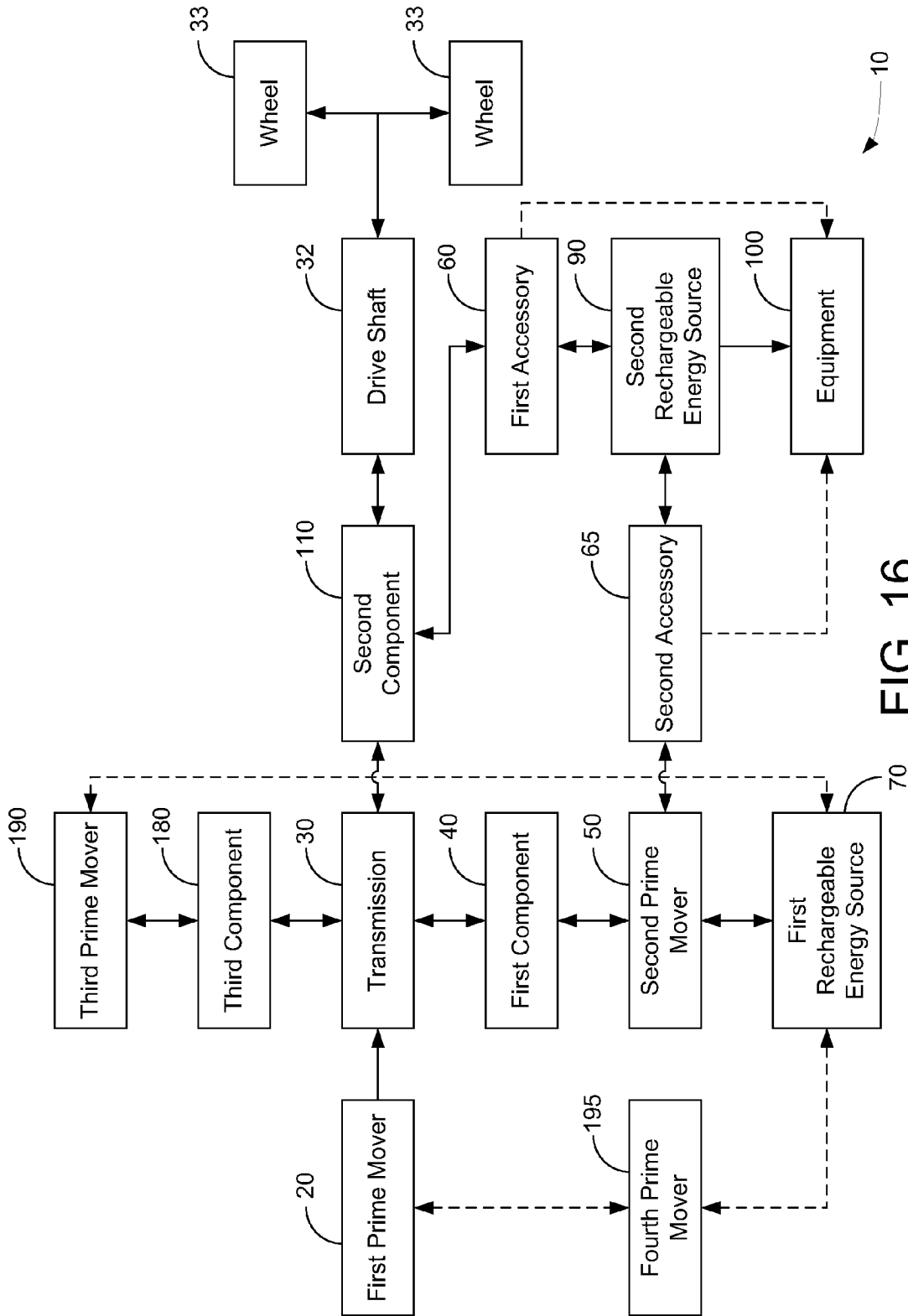

FIG. 16

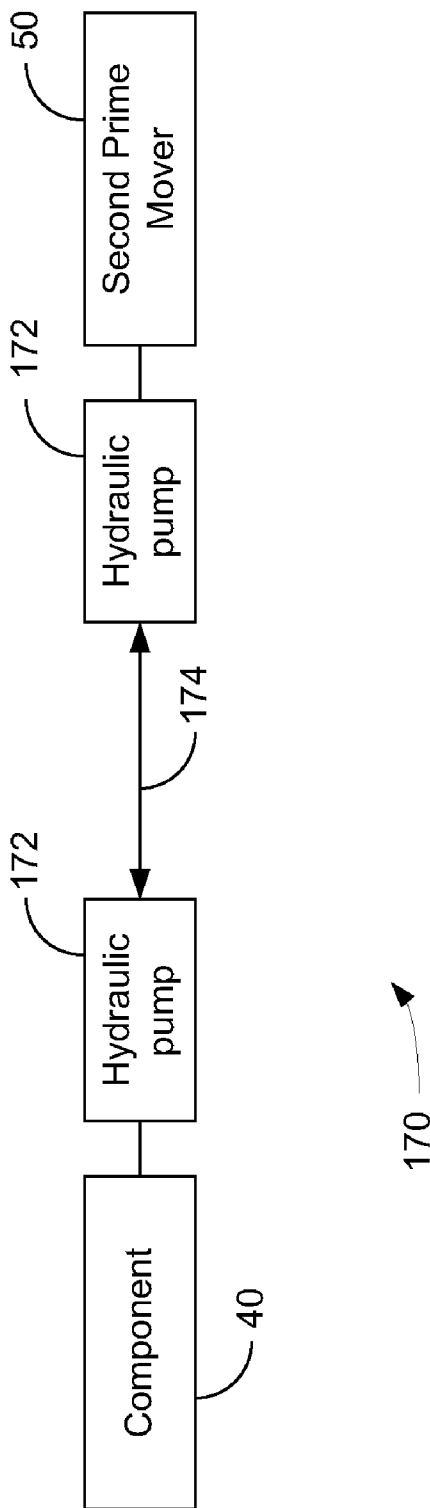

FIG. 17

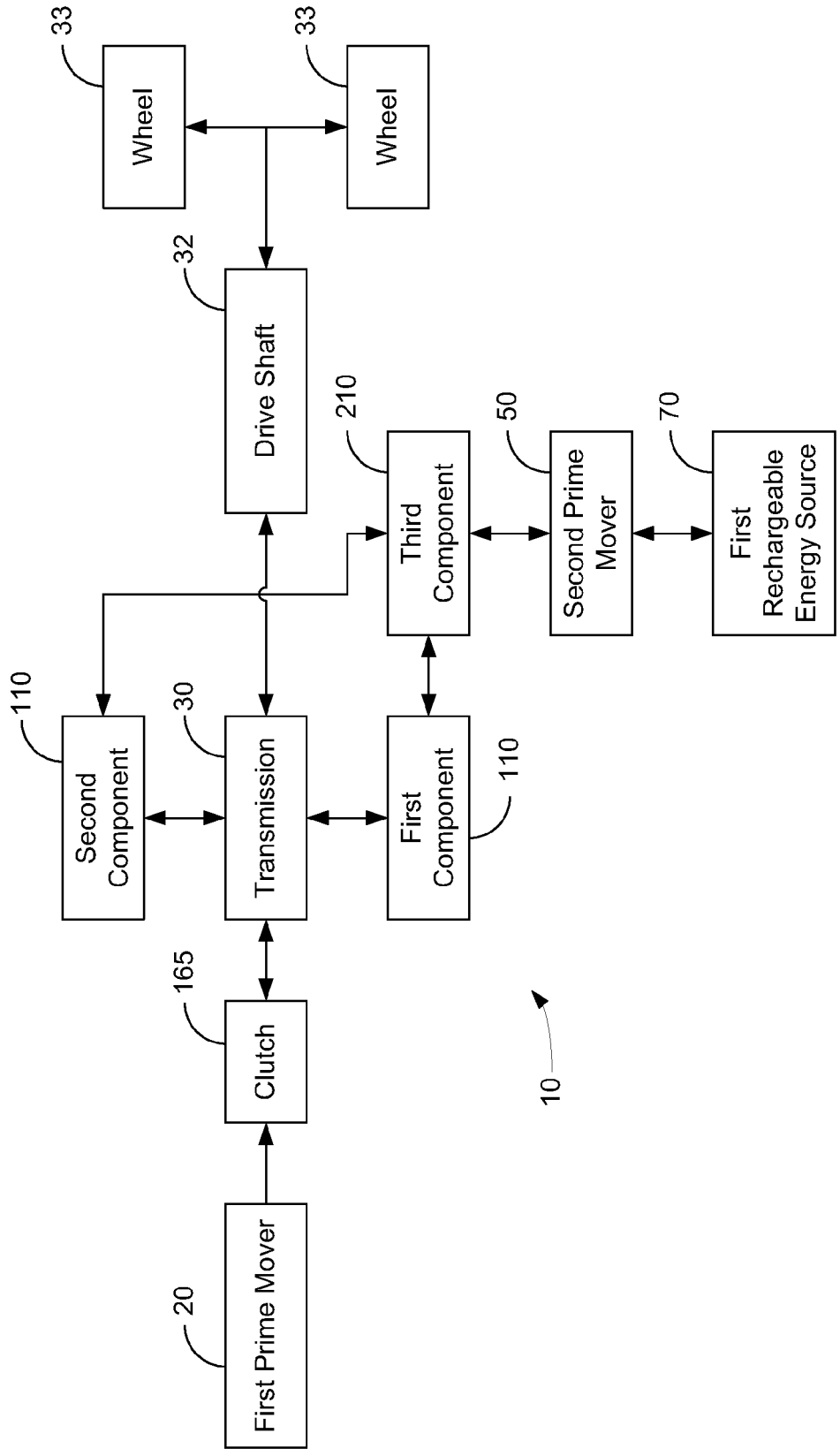

FIG. 18

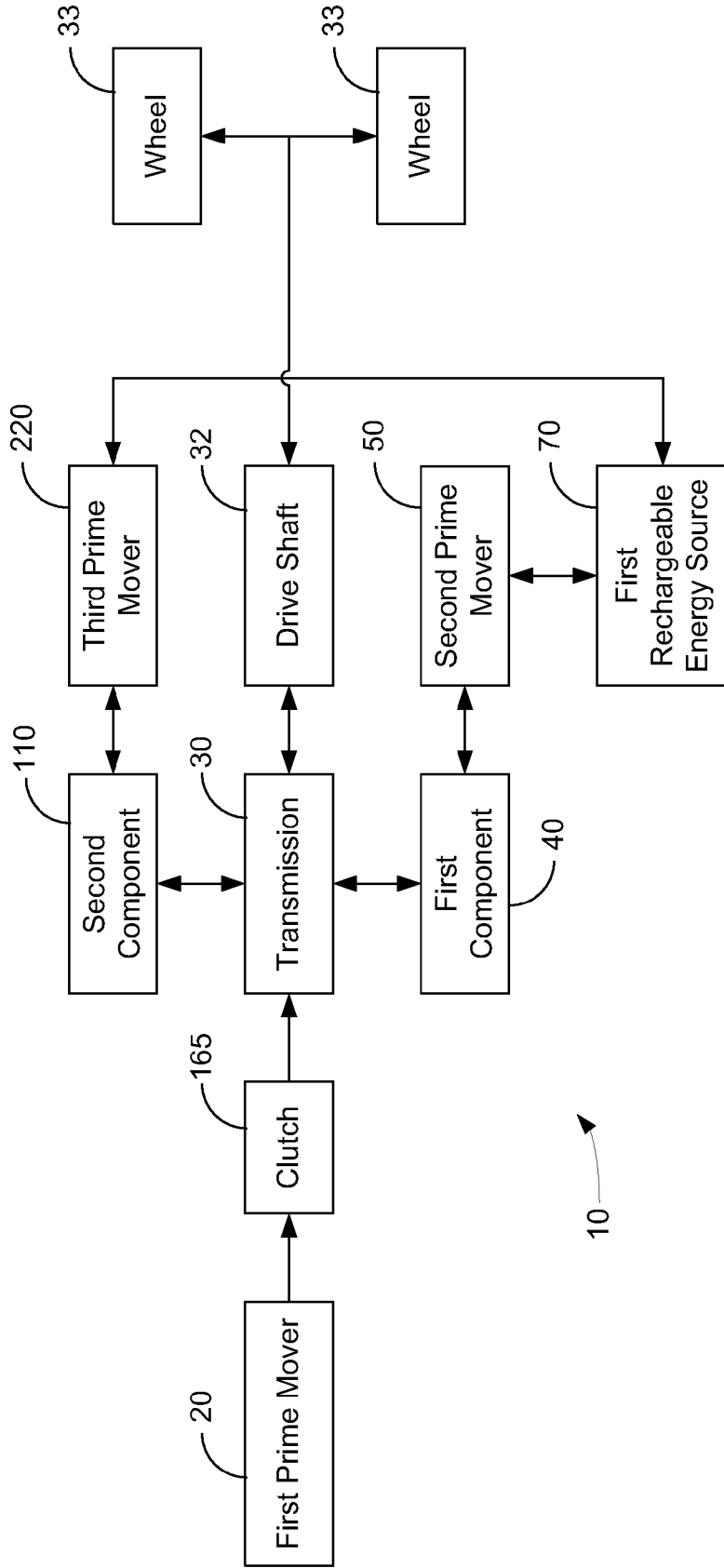

FIG. 19

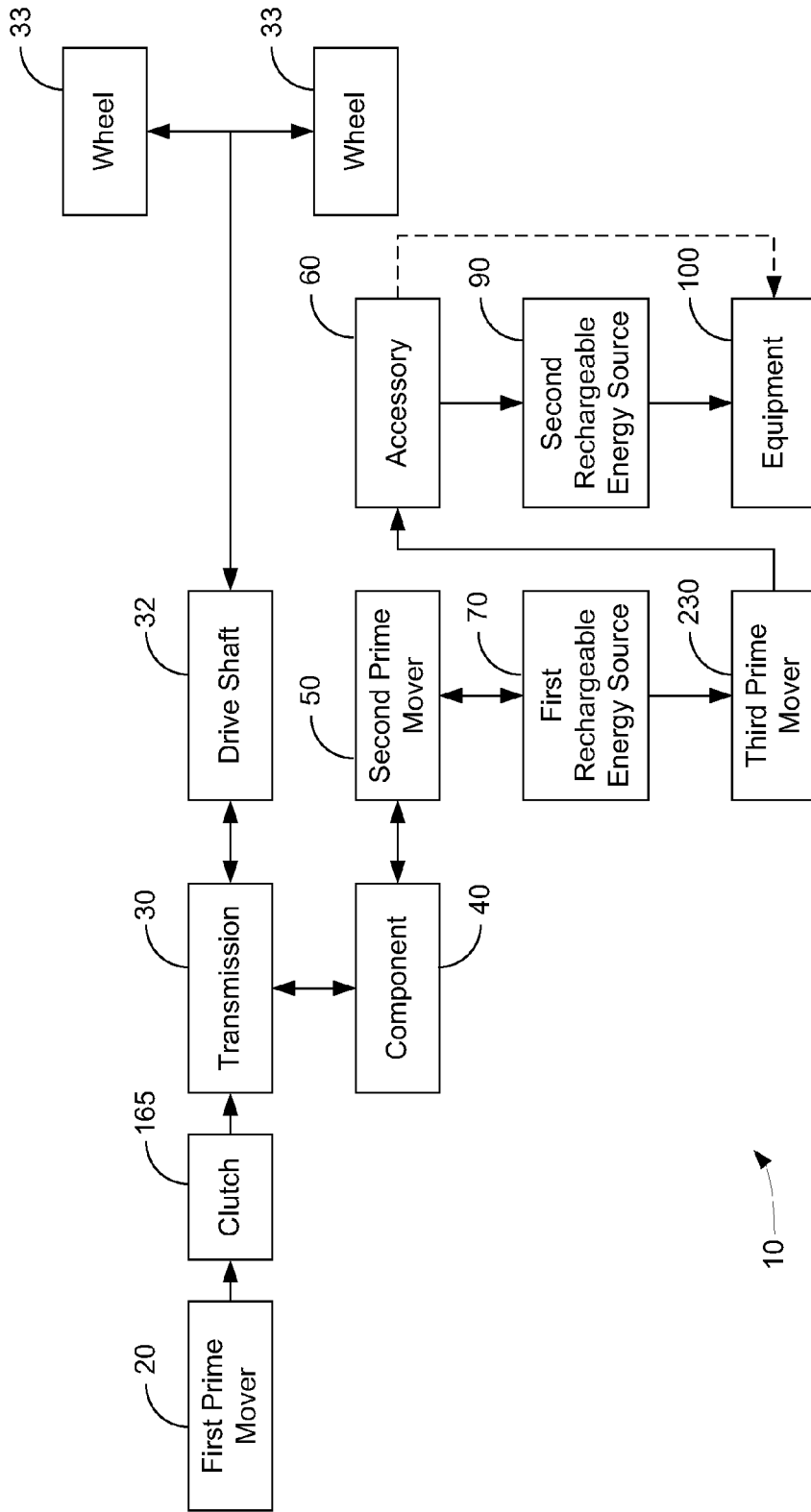

FIG. 20

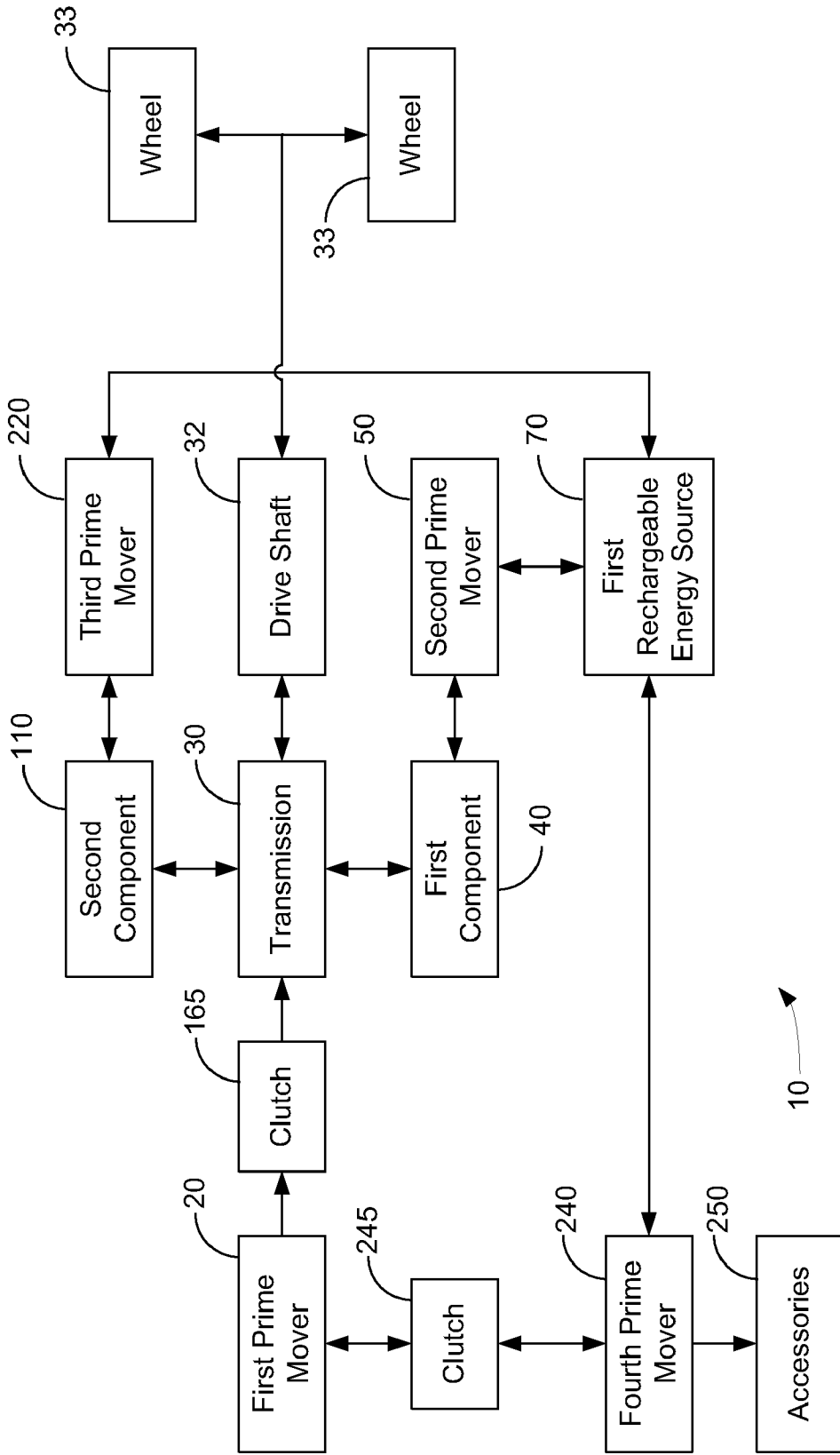

FIG. 21

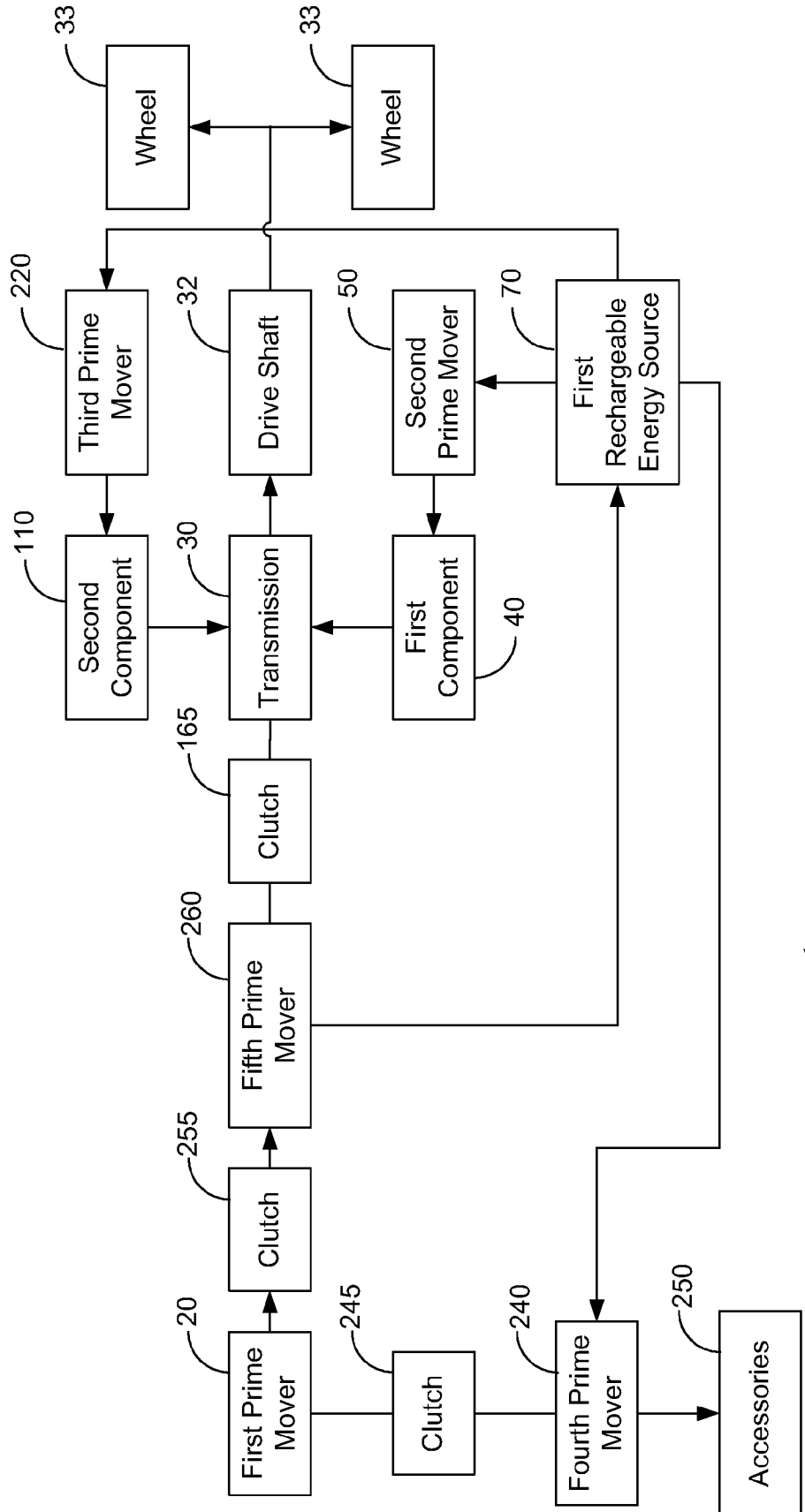

FIG. 22

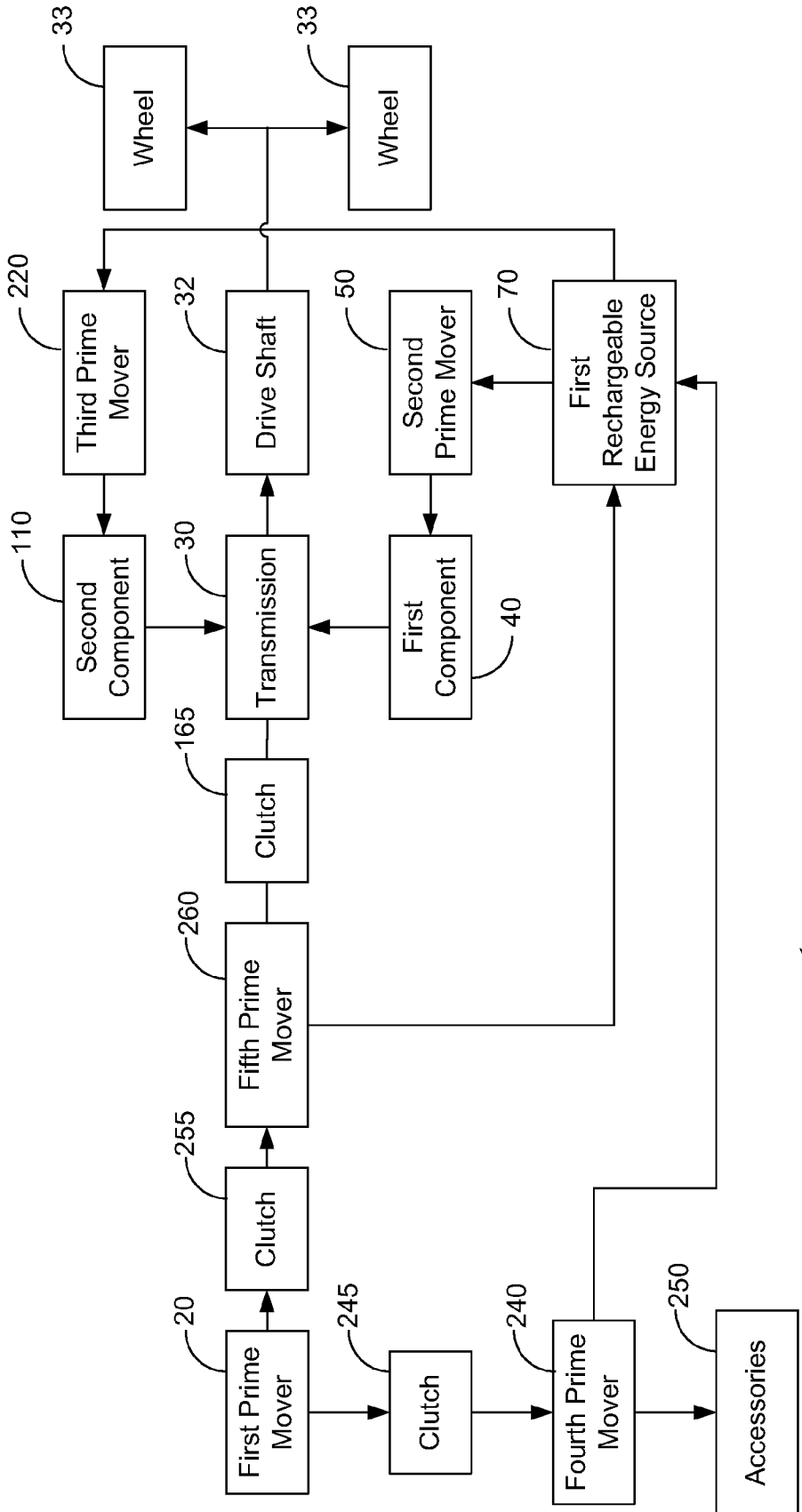

FIG. 23

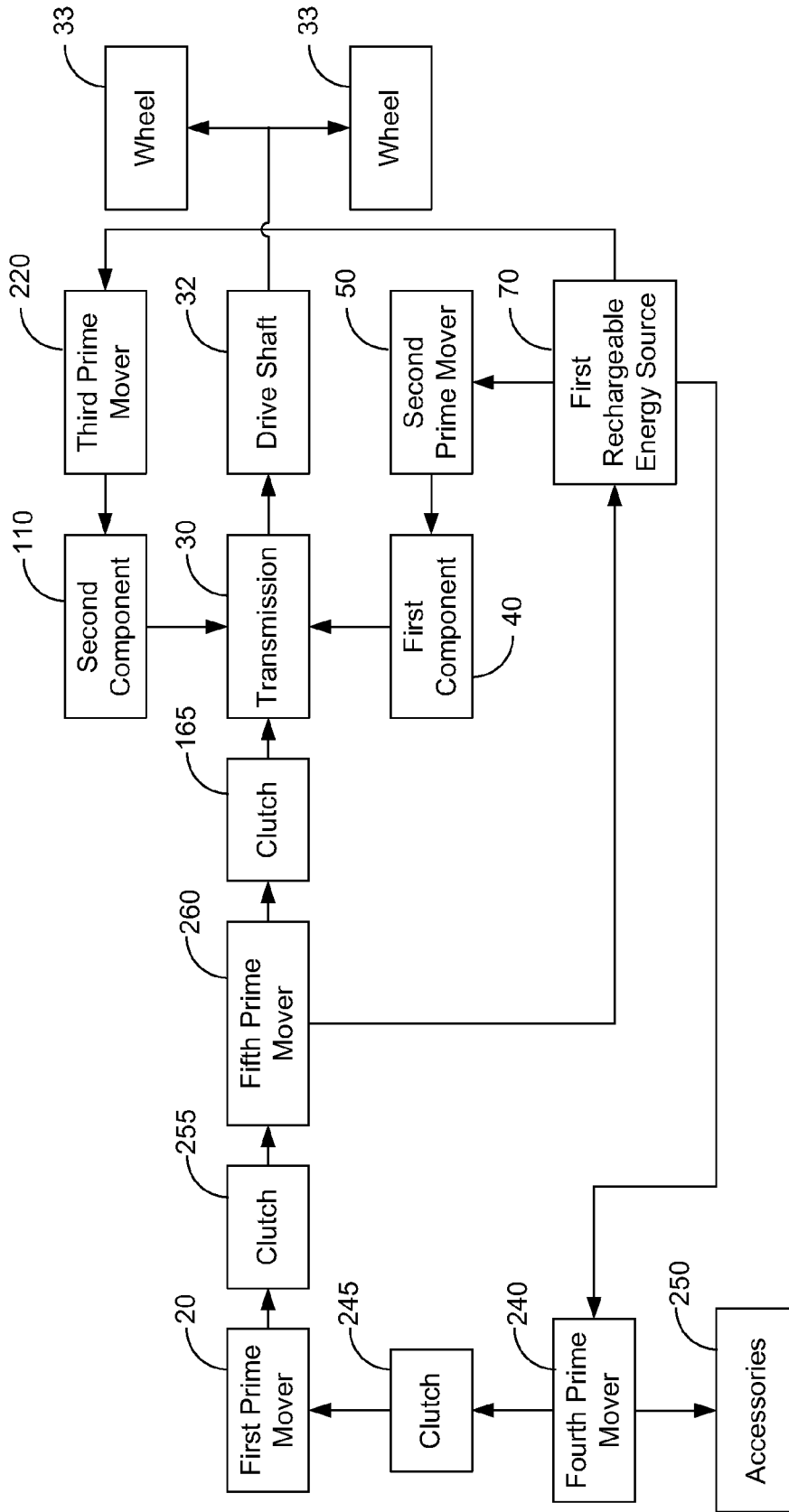

FIG. 24

10

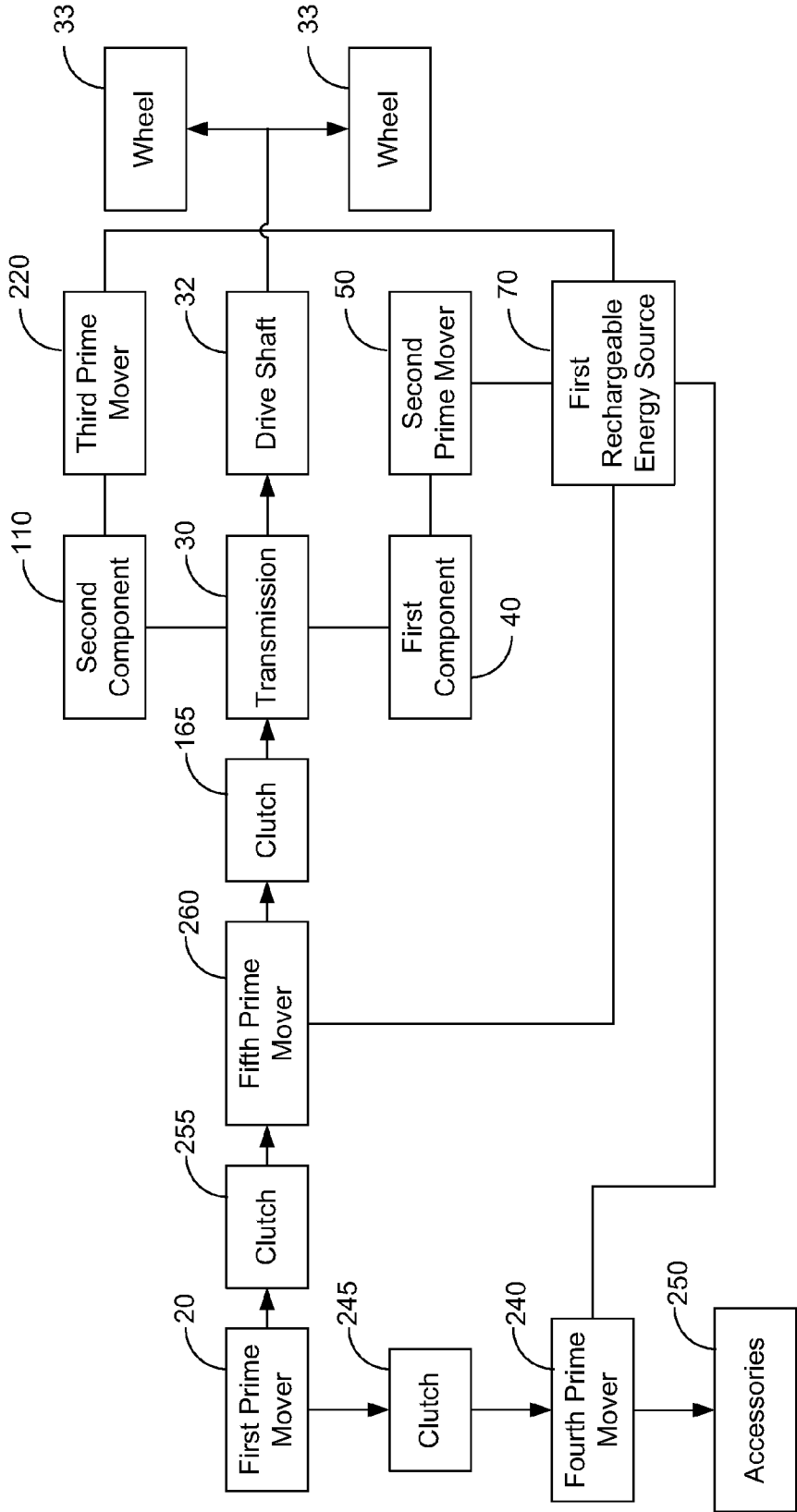

FIG. 25

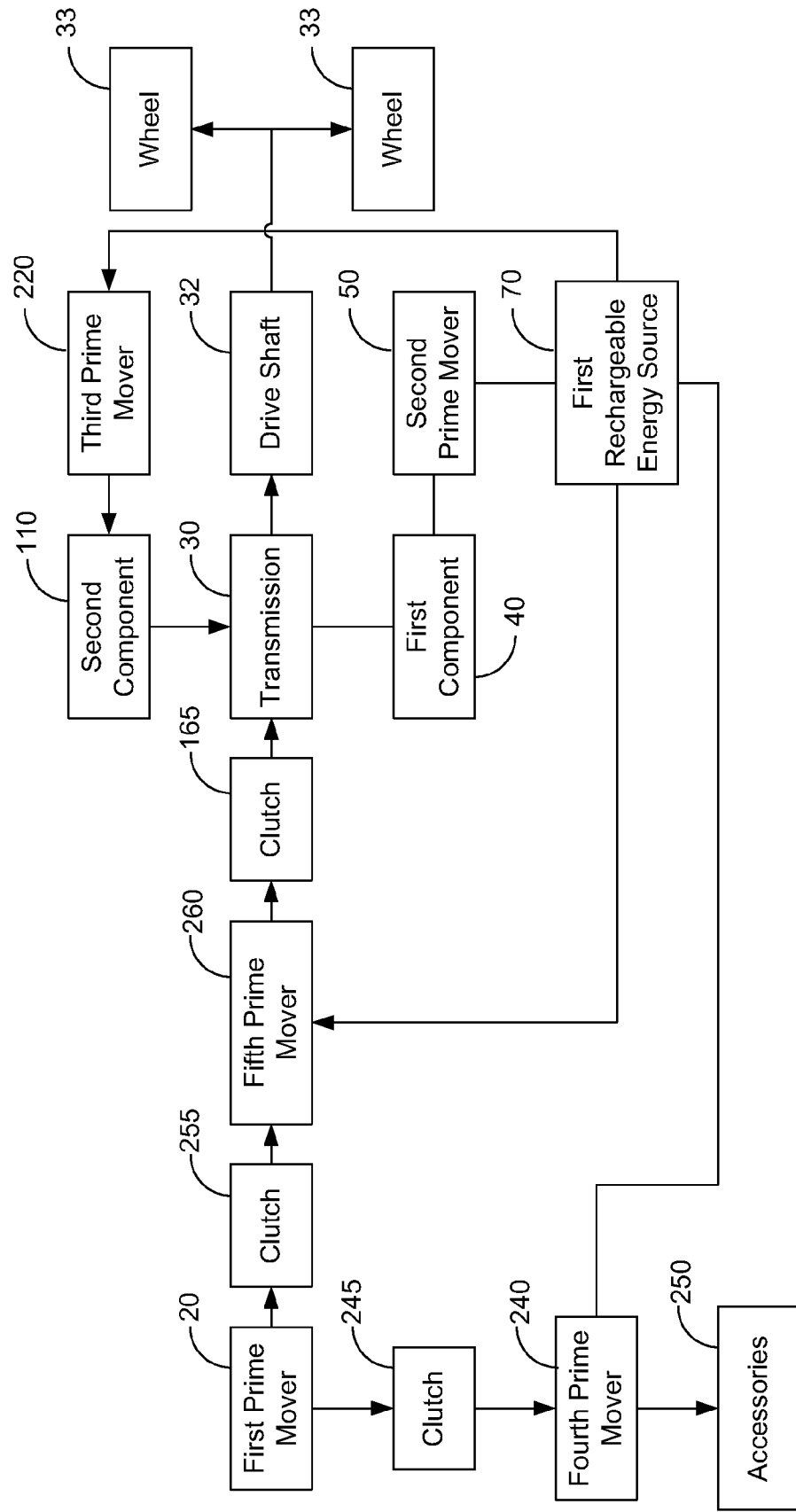

FIG. 26

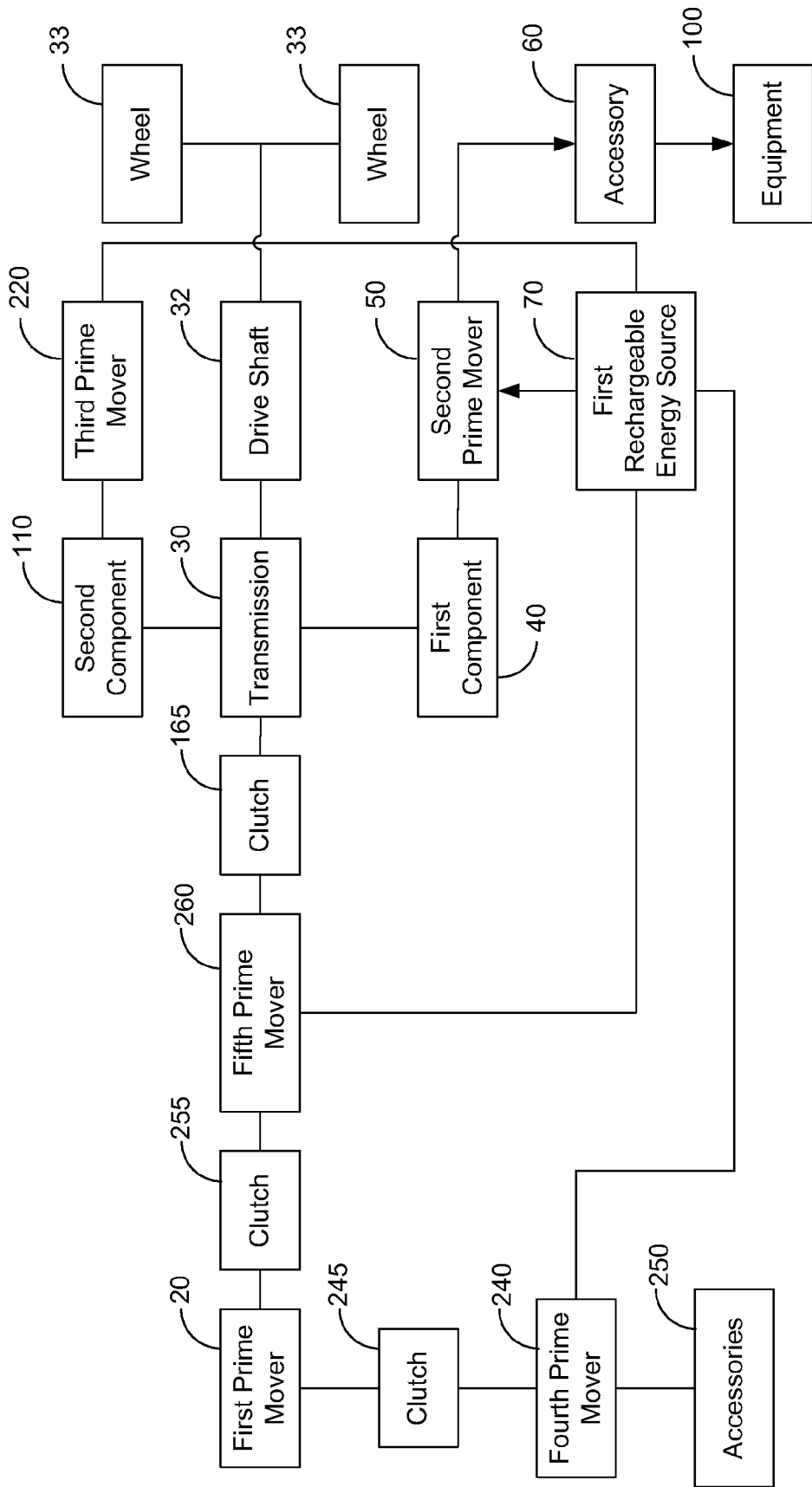

FIG. 27

10 →

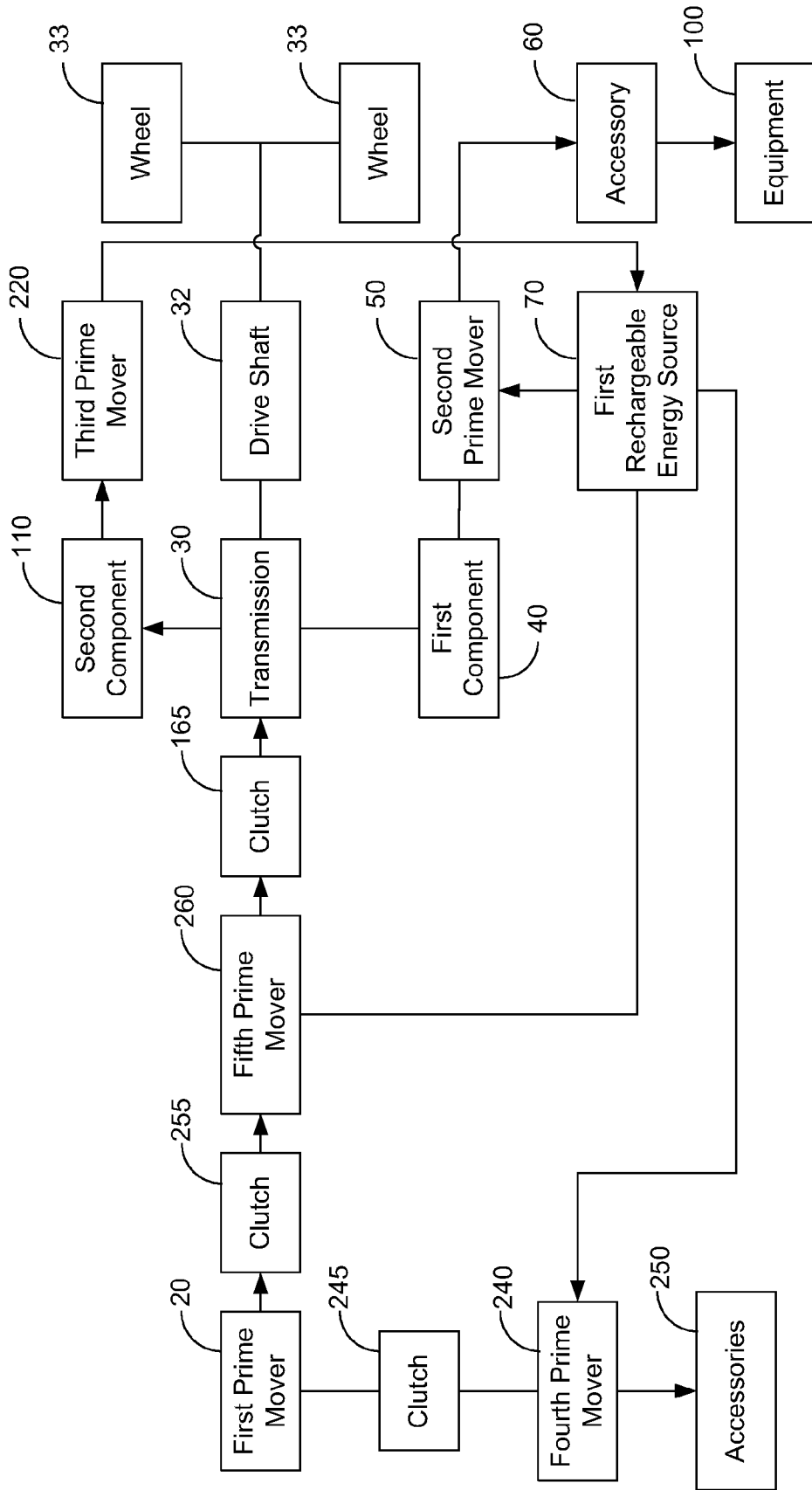

FIG. 28

10

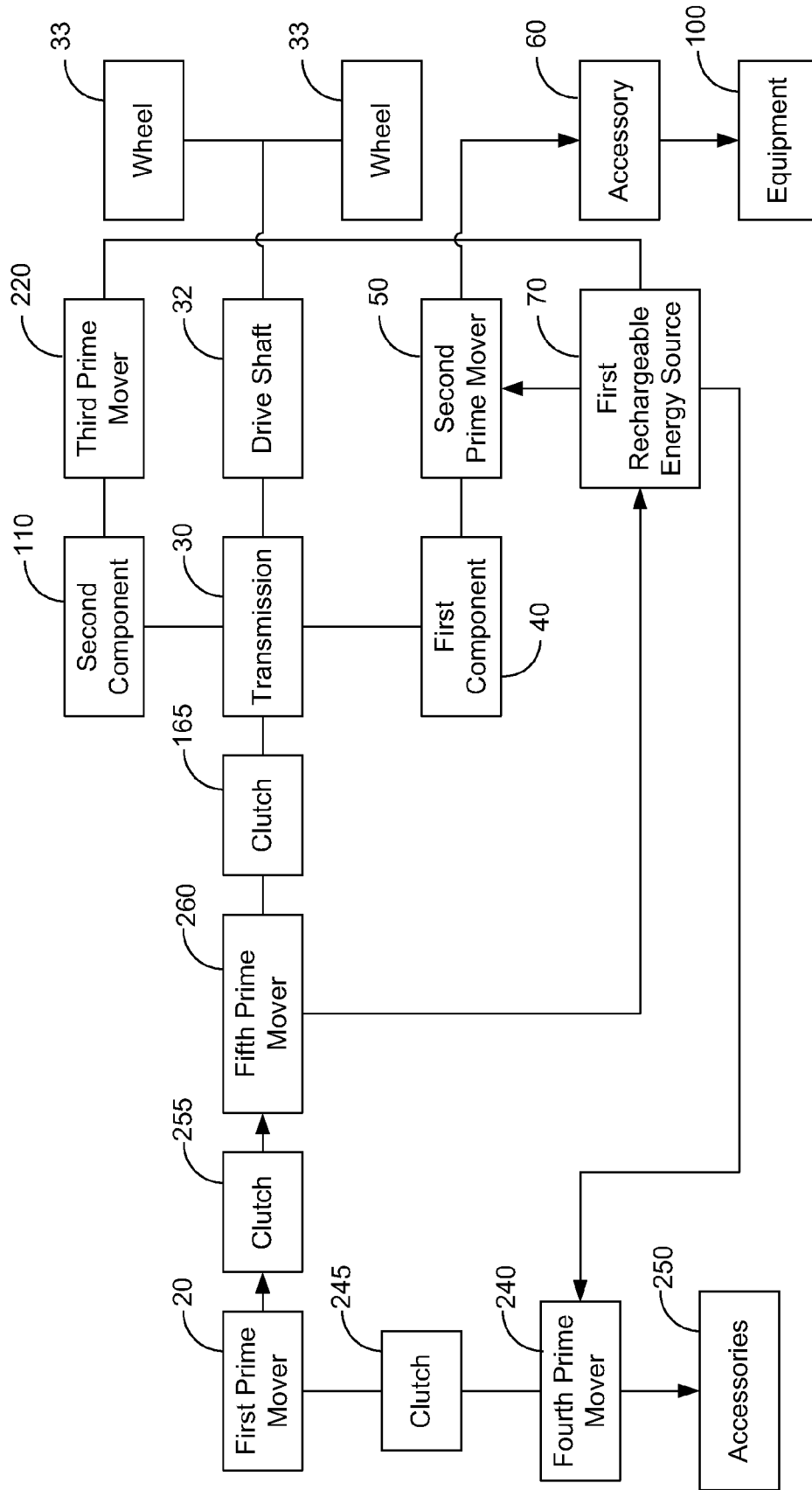

FIG. 29

10

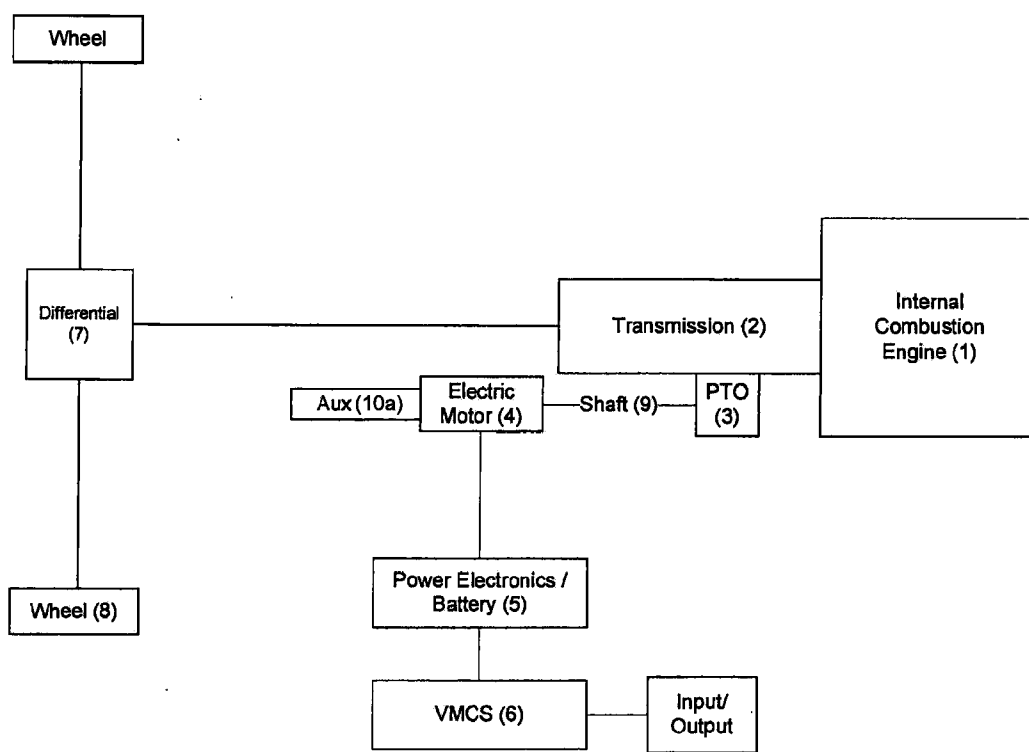

Figure 30

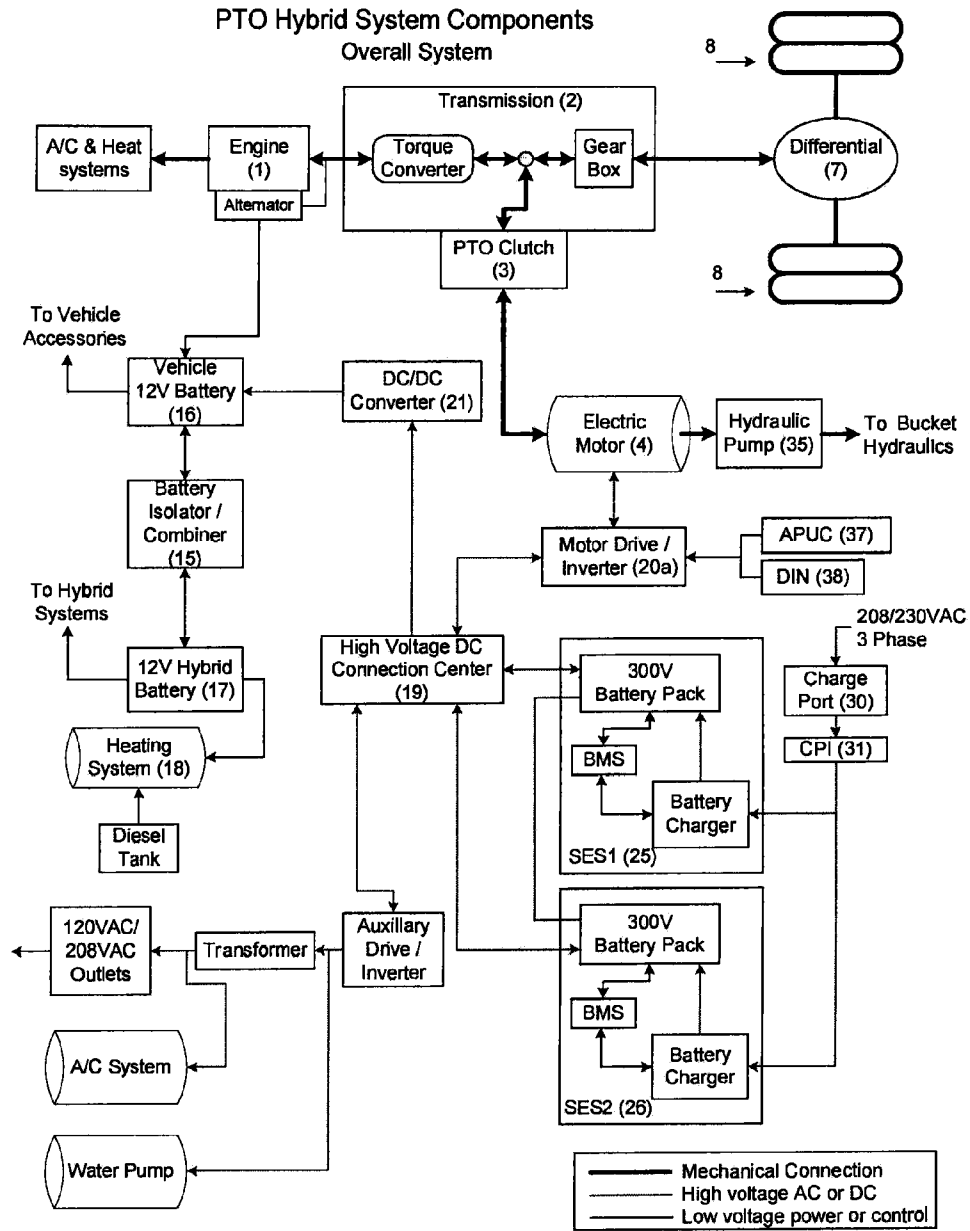

Figure 31

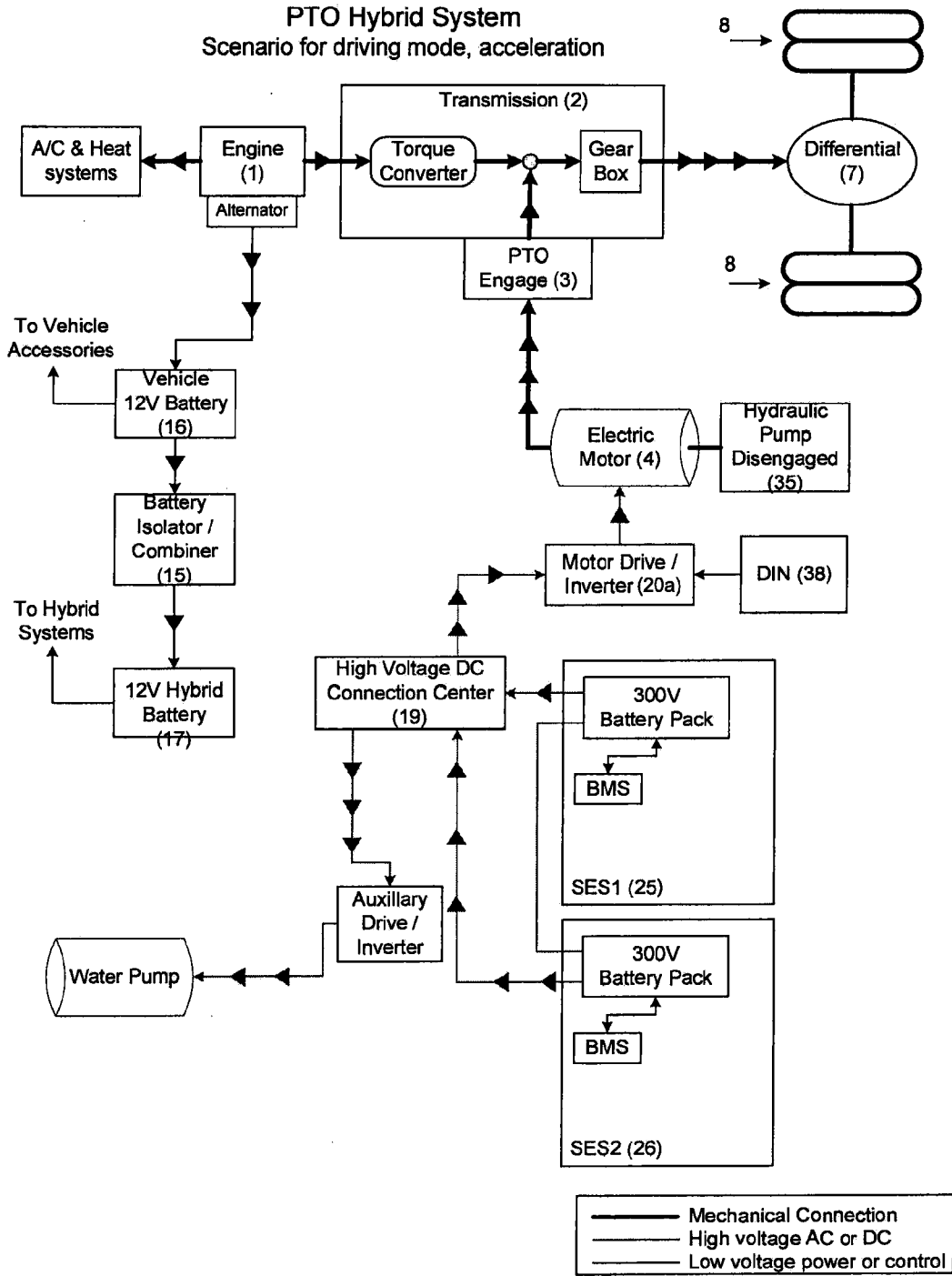

Figure 32

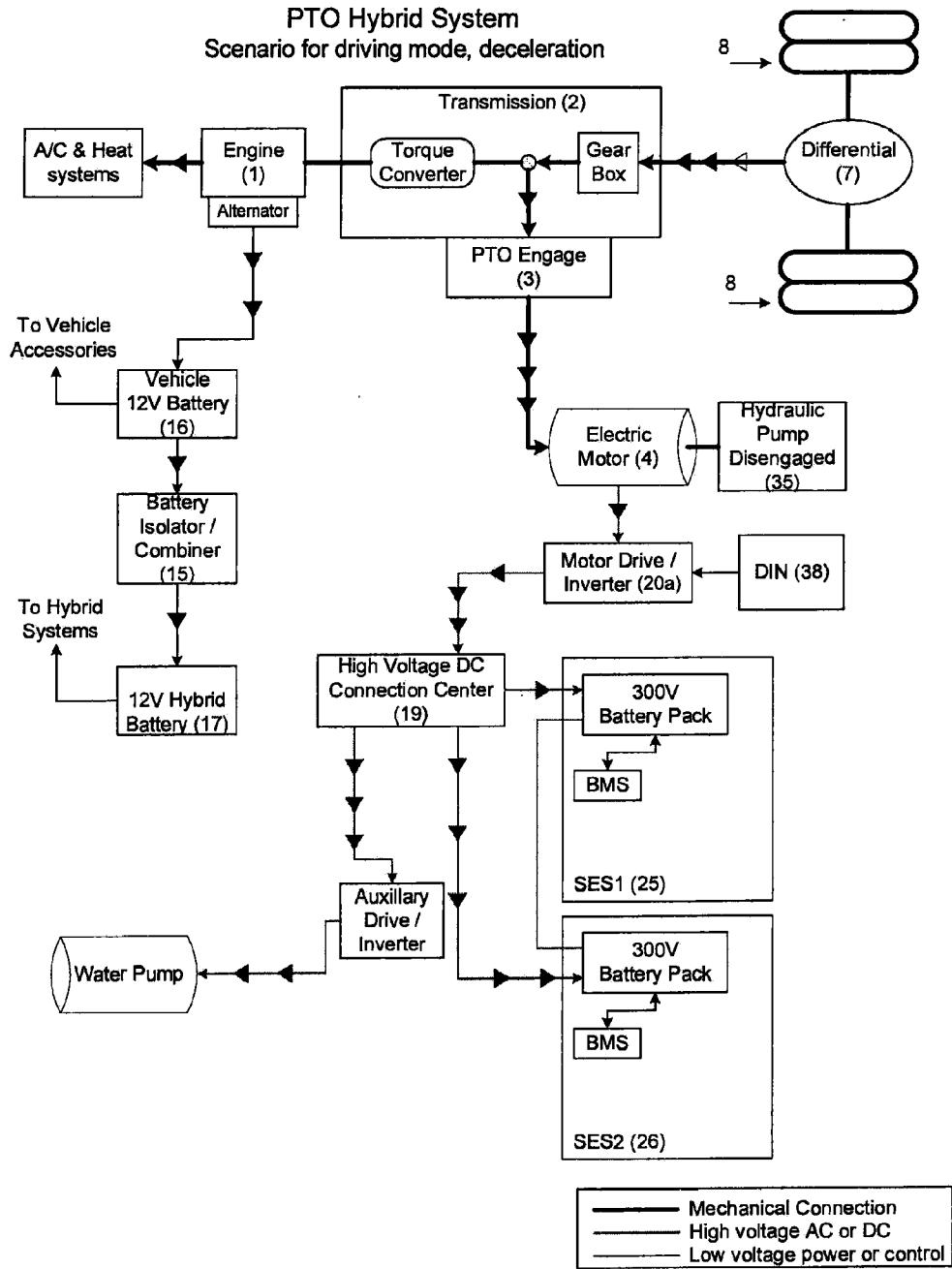

Figure 33

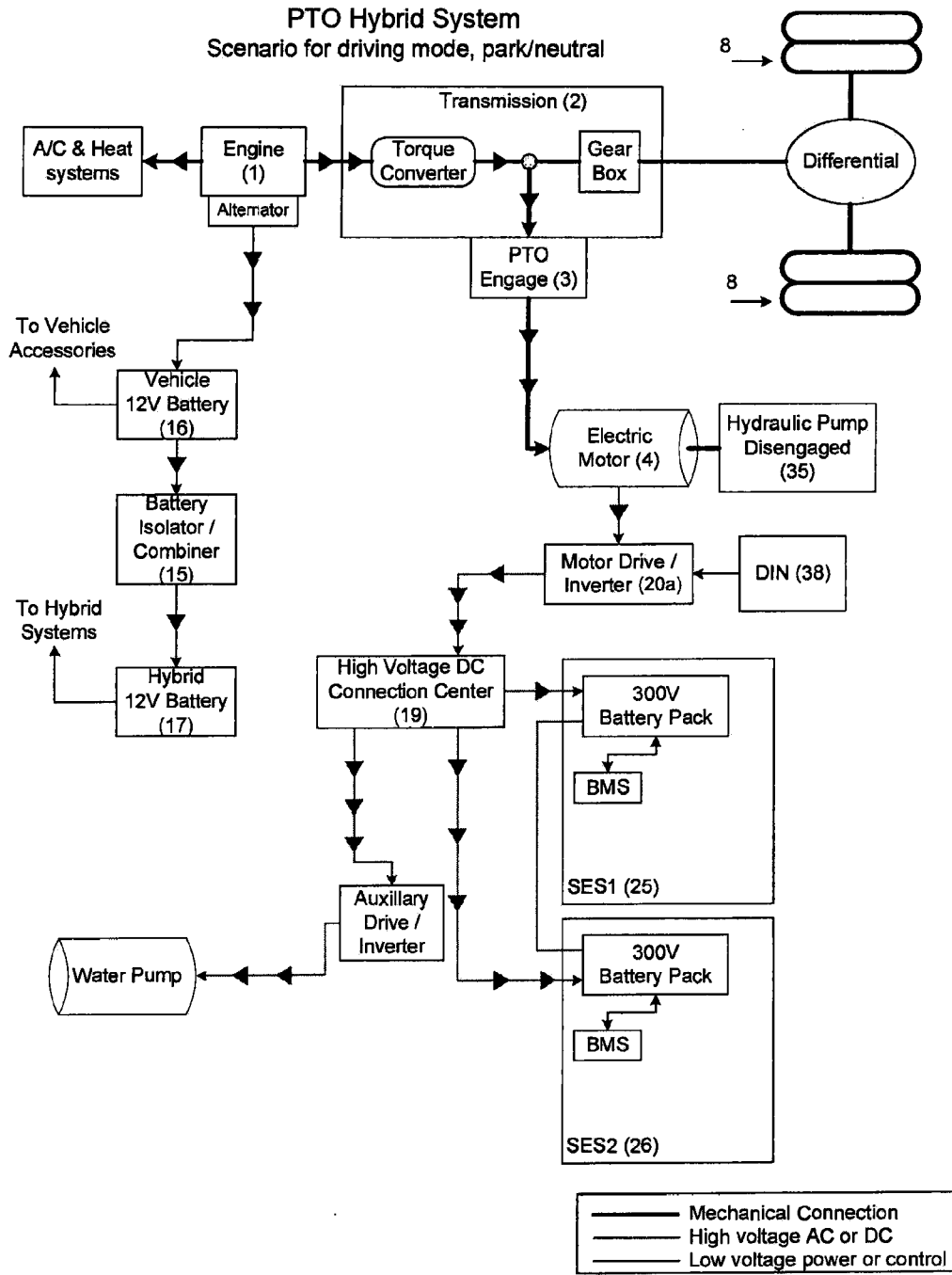

Figure 34

PTO Hybrid System
Scenario for all-electric stationary mode

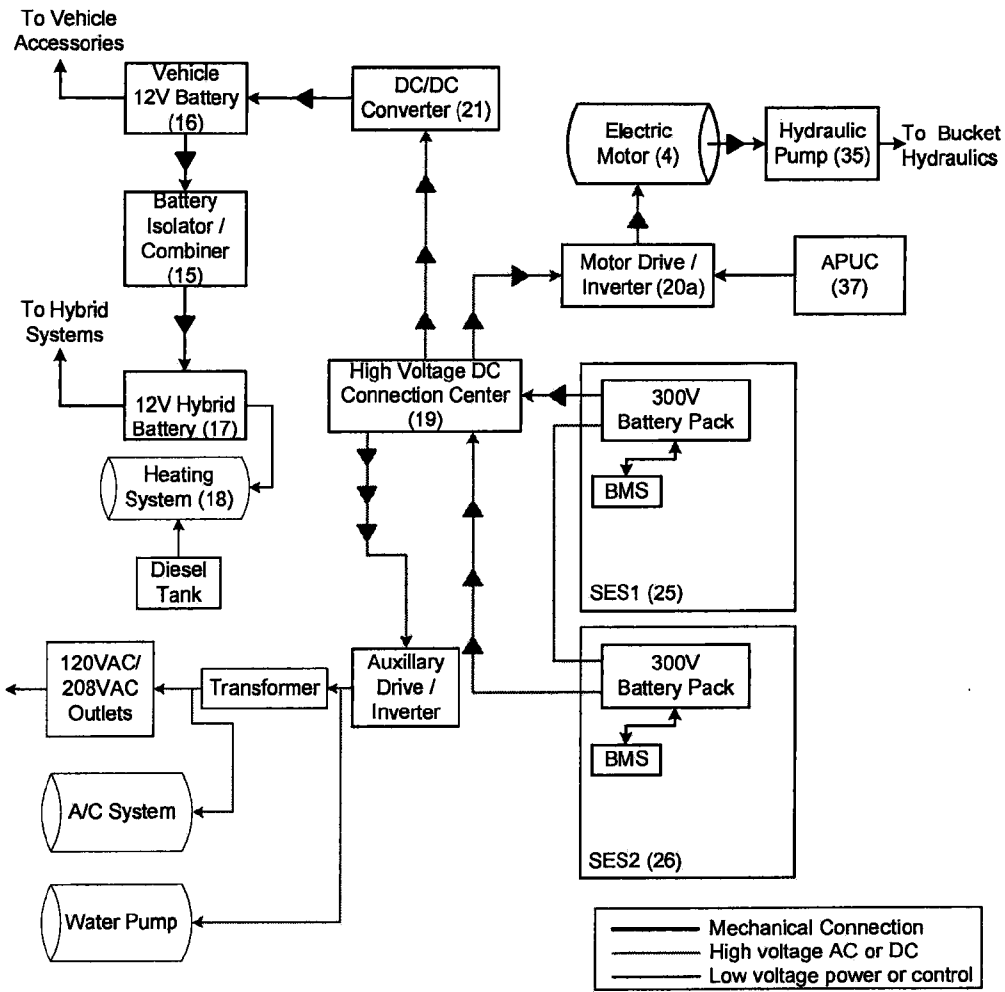

Figure 35

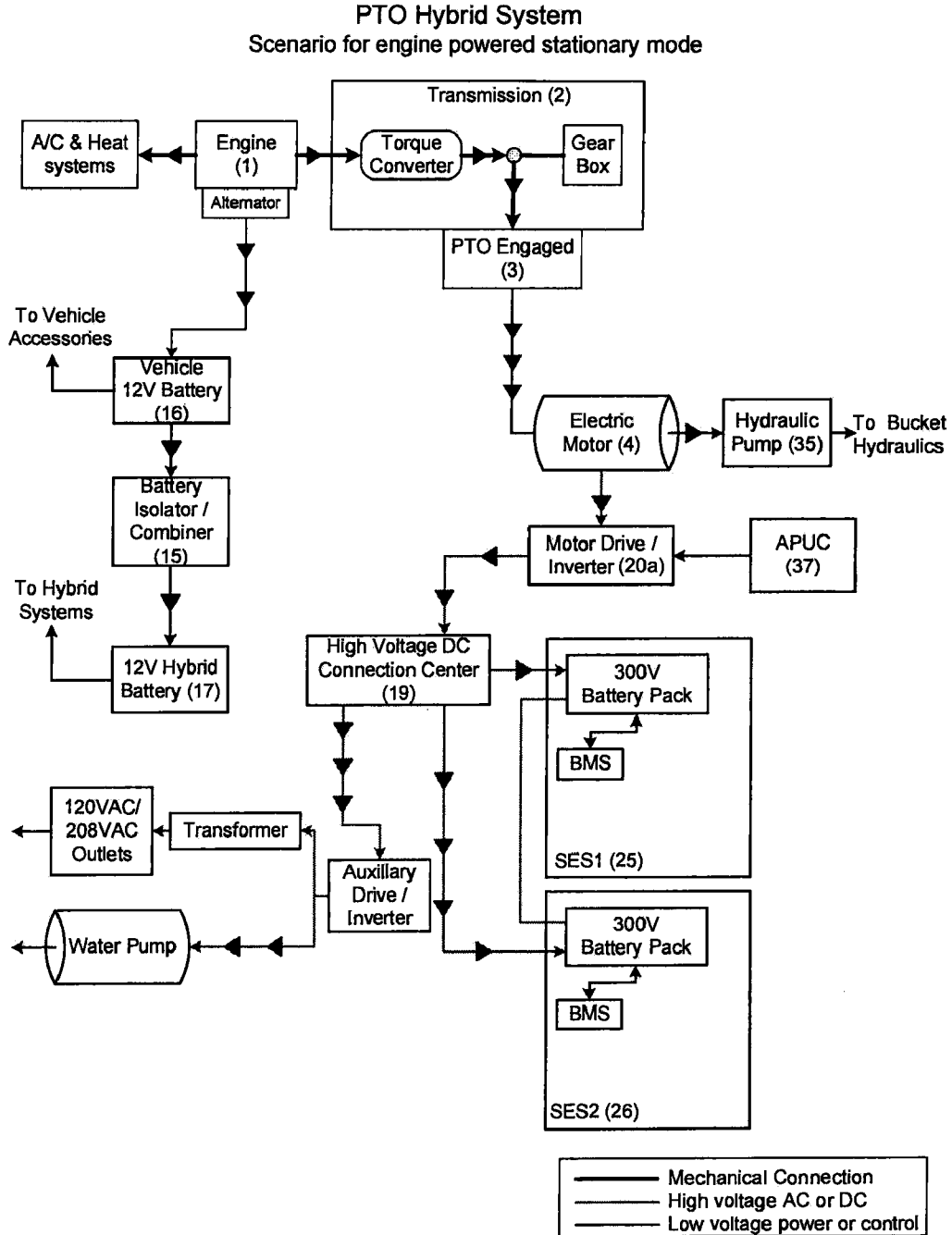

Figure 36

PTO Hybrid System
Scenario for plug-in charging mode

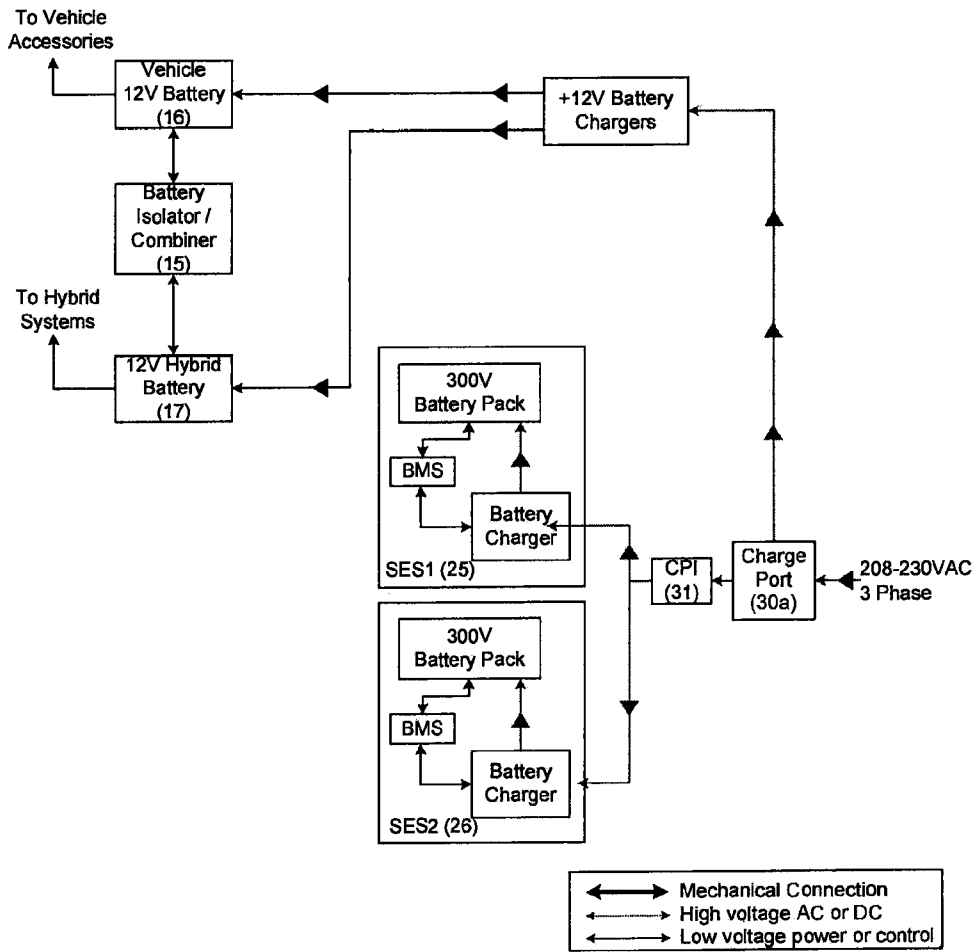

Figure 37

HYBRID VEHICLE DRIVE SYSTEM AND METHOD AND IDLE REDUCTION SYSTEM AND METHOD

CROSS-REFERENCES TO RELATED APPLICATIONS

[0001] The present application claims the benefit of and priority to and is also a continuation-in-part of U.S. application Ser. No. 12/130,888 filed on May 30, 2008⁽⁹⁶⁶³⁷⁻¹⁰⁶⁾ which is incorporated herein by reference in its entirety and claims the benefit of and priority to U.S. Provisional Application Ser. No. 60/979,755 filed Oct. 12, 2007⁽⁹⁶⁶³⁷⁻¹⁰³⁾, which is incorporated herein by reference in its entirety, and U.S. Provisional Application Ser. No. 61/014,406 filed Dec. 17, 2007⁽⁹⁶⁶³⁷⁻¹⁰⁴⁾ which is incorporated herein by reference in its entirety. The present application is also a continuation-in-part of U.S. application Ser. No. 12/217,407 filed on Jul. 3, 2008⁽⁹⁶⁶³⁷⁻¹¹⁵⁾, which is incorporated herein by reference in its entirety, and claims the benefit of and priority to U.S. Provisional Application Ser. No. 60/959,181 filed Jul. 12, 2007^(INV-79701/US1X) which is incorporated herein by reference in its entirety and U.S. Provisional Application Ser. No. 61/126,118, filed May 1, 2008⁽⁹⁶⁶³⁷⁻¹²⁰⁾, which is incorporated herein by reference in its entirety.

BACKGROUND OF THE INVENTION

[0002] The present disclosure relates to vehicle drive systems. More particularly, the present disclosure relates to hybrid vehicle drive systems employing electric and hydraulic components.

[0003] Hybrid vehicle drive systems commonly employ at least two prime movers arranged in different configurations relative to a transmission. One known configuration is found in so-called “series-parallel” hybrids. “Series-parallel” hybrids are arranged such that multiple prime movers can power the drive shaft alone or in conjunction with one another.

[0004] In one known hybrid vehicle drive system, a first and second prime mover (e.g., an internal combustion engine and an electric motor/generator) are arranged in a parallel configuration and used to provide power to a drive shaft and a power take-off (PTO) shaft through a transmission. PTO shafts are generally used to drive auxiliary systems, accessories, or other machinery (e.g., pumps, mixers, barrels, winches, blowers, etc.). One limitation of this system is that the second prime mover is typically positioned between the first prime mover and the transmission, creating the need to reposition existing drive train components.

[0005] In another known hybrid vehicle drive system, a first prime mover (e.g., an internal combustion engine) drives a PTO through a transmission. A second prime mover (e.g., electric motor/generator) has been coupled directly to the PTO. One limitation of this system is that while it allows the electric motor to provide power to a drive shaft through the PTO, it does not provide power to a hydraulic pump for operation of vehicle mounted hydraulic components and equipment. The system also does not use a hydraulic motor/pump as the second prime mover. The system also does not allow a hydraulic motor/pump to be driven by either the internal combustion engine or by the electric motor/generator, nor does it allow the hydraulic motor/pump and electric motor/generator to be simultaneously driven by the engine.

The system also does not use the hydraulic motor/pump and electric motor/generator to simultaneously provide power to a drive shaft.

[0006] Hybrid systems used in larger trucks, greater than Class 4, have typically utilized two basic design configurations—a series design or a parallel design. Series design configurations typically use an internal combustion engine (heat engine) or fuel cell with a generator to produce electricity for both the battery pack and the electric motor. There is typically no direct mechanical power connection between the internal combustion engine or fuel cell (hybrid power unit) and the wheels in an electric series design. Series design hybrids often have the benefit of having a no-idle system, including an engine-driven generator that enables optimum performance, lacking a transmission (on some models), and accommodating a variety of options for mounting the engine and other components. However, series design hybrids also generally include a larger, heavier battery; have a greater demand on the engine to maintain the battery charge; and include inefficiencies due to the multiple energy conversions. Parallel design configurations have a direct mechanical connection between the internal combustion engine or fuel cell (hybrid power unit) and the wheels in addition to an electric or hydraulic motor to drive the wheels. Parallel design hybrids have the benefit of being capable of increased power due to simultaneous use of the engine and electric motor, having a smaller engine with improved fuel economy while avoiding compromised acceleration power, and increasing efficiency by having minimal reduction or conversion of power when the internal combustion engine is directly coupled to the driveshaft. However, parallel design hybrids typically lack a no-idle system and may have non-optimal engine operation (e.g., low rpm or high transient loads) under certain circumstances. Existing systems on trucks of Class 4 or higher have traditionally not had a system that combines the benefits of a series system and a parallel system.

[0007] Therefore, a need exists for a hybrid vehicle drive system and method of operating a hybrid vehicle drive system that allows a drive shaft to receive power from at least three components. There is also a need for a hybrid vehicle drive system that allows for the prevention of friction and wear by disengaging unused components. There is a further need for a hybrid vehicle drive system that uses regenerative braking to store energy in at least two rechargeable energy sources. Still further, there is a need for a PTO-based hybrid system. Further still, there is a need for a hybrid system optimized for use with a hydraulic system of the vehicle.

[0008] The need for engine idle reduction systems and methods also exists. Sophisticated power train control systems and power management systems required for the operation of a hybrid vehicle drive system can add cost and complexity. Therefore there is a need for an idle reduction system that allows equipment to be powered by one pump. There is also a need for a system that allows for quick recharging from three sources (vehicle engine, external power grid, APU). There is also a need for a system that can provide power to the equipment from two sources simultaneously (vehicle engine and electric motor) during periods when equipment power requirements exceed the output of only an electric motor driven pump.

[0009] There is a further need for a series/parallel design in which the system can operate using either series or parallel configurations depending upon which is most advantageous given operating requirements.

SUMMARY

[0010] One embodiment relates to a hybrid vehicle drive system for a vehicle including a first prime mover, a first

prime mover driven transmission, a rechargeable power source, and a PTO. The hybrid vehicle drive system further includes a hydraulic motor in direct or indirect mechanical communication with the PTO and an electric motor in direct or indirect mechanical communication with the hydraulic motor. The electric motor can provide power to the prime mover driven transmission and receive power from the prime mover driven transmission through the PTO. The hydraulic motor can receive power from the electric motor which is powered by the rechargeable power source.

[0011] Another embodiment relates to a hybrid vehicle drive system for a vehicle including a first prime mover, a first prime mover driven transmission, a rechargeable power source, and a PTO. The hybrid vehicle drive system further includes a hydraulic motor in direct or indirect mechanical communication with the PTO and an electric motor in direct or indirect mechanical communication with the hydraulic motor. The electric motor can provide power to the prime mover driven transmission and receive power from the prime mover driven transmission through the PTO. The hydraulic motor can provide power to the prime mover driven transmission and receive power from the prime mover driven transmission through the PTO.

[0012] Another embodiment relates to a hybrid vehicle drive system for use with a first prime mover and a first transmission driven by the first prime mover. The system includes a second prime mover coupled to a rechargeable energy source, a component, and an accessory configured to be coupled to the second prime mover. The first prime mover is configured to provide power through the transmission and the component to operate the second prime mover, and the second prime mover is configured to provide power to the drive shaft through the component. The accessory is configured to operate through the operation of the second prime mover.

[0013] Yet another embodiment relates to a hydraulic system used in a hybrid vehicle of any type. The vehicle includes a first prime mover, a first prime mover driven transmission, a second prime mover, a component, and a first rechargeable energy source. The first prime mover can provide power to the second prime mover through the transmission and the component. The second prime mover can provide power to the vehicle's drive shaft through the component. The first rechargeable energy source can power the second prime mover or be recharged by the second prime mover. The hydraulic system includes an accessory. The accessory can be coupled to the second prime mover in such a way that the accessory is operated through operation of the second prime mover. The accessory can also operate the second prime mover.

[0014] Yet another embodiment relates to a method of operating a hybrid vehicle drive system. The drive system includes a first prime mover, a first prime mover driven transmission, a second prime mover, a first rechargeable energy source, a component, and an accessory. The second prime mover can effect the motion of a drive shaft alone or in combination with the first prime mover. The first rechargeable energy source can power or be recharged by the second prime mover. The component transfers energy between the transmission and the second prime mover in both directions. Operation of the second prime mover powers the accessory, and the accessory can also operate to power the second prime mover.

[0015] A first and second electric motor are coupled to the power source. One is indirect and one is in with PTO,

whereby the first E motor can either provide propulsion or generate power and the second E motor can either provide power to the PTO driven transmission or receive power for regeneration braking. An optional hydraulic motor coupled after the second electric motor can act as a generator or as a motor.

[0016] Yet another embodiment relates to a hybrid vehicle drive system for a vehicle including a first prime mover, a first prime mover driven transmission, a rechargeable power source, and a PTO. The hybrid vehicle drive system further includes a first electric motor coupled to the power source, a hydraulic motor in direct or indirect mechanical communication with the first electric motor, and a second electric motor in direct or indirect mechanical communication with the PTO. The second electric motor can receive power from the prime mover driven transmission through the PTO and charge the power source. The hydraulic motor can receive power the first electric motor. The second electric motor has a higher horsepower rating than the first electric motor.

[0017] Another exemplary embodiment relates to a hybrid vehicle drive system for a vehicle including a first prime mover, a first prime mover driven transmission, a rechargeable power source, and a PTO. The hybrid vehicle drive system further includes a first electric motor and a second electric motor coupled to the power source. The second electric motor is in direct or indirect mechanical communication with the PTO. The first electric motor is in direct or indirect communication with the first prime mover. The first electric motor can either provide propulsion or generate power and the second electric motor can either provide power to the PTO for the transmission or receive power via regenerated braking. An optional hydraulic motor can be coupled to the second electric motor. According to one alternative embodiment, one of the first and second electric motors can operate as a generator while the other of the first and second electric motors operates as a motor.

BRIEF DESCRIPTION OF THE DRAWINGS

[0018] Embodiments will be described with reference to the accompanying drawings, in which:

[0019] FIG. 1 is a general block diagram of a hybrid vehicle drive system illustrating paths of possible power sources for the drive shaft according to an exemplary embodiment.

[0020] FIG. 2 is a general block diagram illustrating the operation of a hybrid vehicle drive system using an auxiliary power unit, second prime mover and accessory components to operate equipment according to an exemplary embodiment.

[0021] FIG. 3 is a general block diagram illustrating the operation of a hybrid vehicle drive system with the addition of a second rechargeable energy source according to an exemplary embodiment.

[0022] FIG. 4 is a general block diagram illustrating the operation of a hybrid vehicle drive system using a first prime mover providing power to simultaneously charge a first rechargeable energy source and operate equipment according to an exemplary embodiment.

[0023] FIG. 5 is a general block diagram illustrating the operation of a hybrid vehicle drive system using a first prime mover providing power to simultaneously charge first and second rechargeable energy sources according to an exemplary embodiment.

[0024] FIG. 6 is a general block diagram illustrating the operation of a hybrid vehicle drive system during regenerative braking according to an exemplary embodiment.

[0025] FIG. 7 is a general block diagram illustrating the operation of a hybrid vehicle drive system simultaneously charging first and second rechargeable energy sources during regenerative braking according to an exemplary embodiment.

[0026] FIG. 8 is a general block diagram of a hybrid vehicle drive system illustrating the use of a transfer case instead of a power take-off from the transmission according to an exemplary embodiment.

[0027] FIG. 9 is a general block diagram of a hybrid vehicle drive system illustrating the use of a second power take-off, a third prime mover, and a second accessory component.

[0028] FIG. 10 is a general block diagram of a hybrid vehicle drive system illustrating the use of a second power take-off and a motor according to an exemplary embodiment.

[0029] FIG. 11 is a general block diagram of a hybrid vehicle drive system illustrating the use of a second power take-off, a high horsepower motor, and a capacitor according to an exemplary embodiment.

[0030] FIG. 12 is a general block diagram of a hybrid vehicle drive system illustrating the use of a second accessory component, a high horsepower motor, and a capacitor coupled to the first prime mover according to an exemplary embodiment.

[0031] FIG. 13 is a general block diagram of a hybrid vehicle drive system including an accessory coupled to a power take-off and a second prime mover coupled to the accessory according to an exemplary embodiment.

[0032] FIG. 14 is a general block diagram of a hybrid vehicle drive system similar to the system of FIG. 13 that includes a clutch between the accessory and the power take-off according to an exemplary embodiment.

[0033] FIG. 15 is a general block diagram of a hybrid vehicle drive system similar to the system of FIG. 13 that includes a clutch between the first prime mover and the transmission according to an exemplary embodiment.

[0034] FIG. 16 is a general block diagram of a hybrid vehicle drive system including a second prime mover coupled to a PTO and an accessory coupled to a transfer case according to an exemplary embodiment.

[0035] FIG. 17 is a general block diagram of a fluid coupling connecting two exemplary elements of a hybrid vehicle drive system according to an exemplary embodiment.

[0036] FIG. 18 is a general block diagram of a hybrid vehicle drive system that includes a multi-input/output drive coupled to first and second PTOs according to an exemplary embodiment.

[0037] FIG. 19 is a general block diagram of a hybrid vehicle drive system that does not include hydraulic drive components and includes electric motors coupled to each of two PTOs coupled to the first prime mover according to an exemplary embodiment.

[0038] FIG. 20 is a general block diagram of a hybrid vehicle drive system that includes a smaller electric motor as a third prime mover to power a hydraulic pump according to an exemplary embodiment.

[0039] FIG. 21 is a general block diagram of a hybrid vehicle drive system that does not include hydraulic drive components and includes electric motors coupled to each of two PTOs coupled to the first prime mover along with an

electric motor coupled to the internal combustion engine to power on-board accessories according to an exemplary embodiment.

[0040] FIG. 22 is a general block diagram of a hybrid vehicle drive system in series mode operation in accordance with an exemplary embodiment.

[0041] FIG. 23 is a general block diagram of a hybrid vehicle drive system in a series mode of operation in accordance with an exemplary embodiment.

[0042] FIG. 24 is a general block diagram of a hybrid vehicle drive system in a parallel mode of operation in accordance with an exemplary embodiment.

[0043] FIG. 25 is a general block diagram of a hybrid vehicle drive system in a cruising mode in accordance with an exemplary embodiment.

[0044] FIG. 26 is a general block diagram of a hybrid vehicle drive system in a cruising mode in accordance with an exemplary embodiment.

[0045] FIG. 27 is a general block diagram of a hybrid vehicle drive system when the vehicle is stationary in accordance with an exemplary embodiment.

[0046] FIG. 28 is a general block diagram of a hybrid vehicle drive system when the first prime mover is used to recharge the energy source in accordance with an exemplary embodiment.

[0047] FIG. 29 is a general block diagram of a hybrid vehicle drive system when the first prime mover is used to recharge the energy source in accordance with an exemplary embodiment.

[0048] FIG. 30 is a high level block diagram showing the relationship between the major hardware elements and the embodiment.

[0049] FIG. 31 is a detailed block diagram of the components and subsystems of the entire vehicle system of the embodiment illustrated in FIG. 30.

[0050] FIG. 32 is a diagram showing only those blocks used during vehicle acceleration along with arrows indicating power flows for the embodiment illustrated in FIG. 30.

[0051] FIG. 33 is a diagram showing only those blocks used during vehicle deceleration including arrows to show power flow directions in the embodiment illustrated in FIG. 30.

[0052] FIG. 34 is a diagram showing the blocks used in the driving mode of "park/neutral" with arrows showing possible power flow paths in the embodiment illustrated in FIG. 30.

[0053] FIG. 35 is a diagram showing the blocks involved in the support of an all-electric stationary mode also indicating power flow directions via arrows in the embodiment illustrated in FIG. 30.

[0054] FIG. 36 is a diagram showing the elements involved in supporting an engine powered stationary mode indicating power flow directions in the embodiment illustrated in FIG. 30.

[0055] FIG. 37 is a diagram showing the blocks and power flows involved in the plug-in charging mode of the PTO Hybrid System in the embodiment illustrated in FIG. 30.

DETAILED DESCRIPTION

[0056] Hybrid vehicle drive systems according to several possible embodiments are presented. One feature of one exemplary embodiment of the hybrid vehicle drive system is that a drive shaft can be powered singly or in any combination by a first prime mover, a second prime mover, and an accessory. Preferred embodiments incorporate hydraulic systems into the hybrid vehicle drive system for optimal energy stor-

age and usage. It is noted that the term motor as used herein refers to a motor/generator or motor/pump and is not limited to a device that performs only motor operations.

[0057] Another feature of one exemplary embodiment of the system is that when a power take-off (PTO) configured to be engaged or disengaged while a transmission is moving is used, any unneeded drive system components other than a first prime mover can be entirely disconnected from the drive train, reducing inefficiencies and wear in situations where the different portions of the system do not need to interact, such as when a drive shaft is solely driven by the first prime mover, or when a vehicle using the system is stationary and a second prime mover and accessory are not being driven by the first prime mover. Similarly, an optional clutch between the first prime mover and the transmission can be used to reduce inefficiencies during regenerative braking by removing the first prime mover from the system when vehicle braking occurs.

[0058] Yet another feature of one exemplary embodiment of the system is that the accessory (e.g., hydraulic pump, pneumatic pump, electric motor, etc.) can be powered singly or in any combination by the first prime mover, the second prime mover, energy from braking, or energy stored in a second rechargeable energy source (e.g., battery, ultra capacitor, hydraulic accumulator, etc.). The presence of a second rechargeable energy source also can obviate the need for a complicated pump control system when the accessory is a hydraulic pump. If the pump is a variable volume displacement pump, further simplification is possible because a clutch may not be needed between the second prime mover and the pump. Other types of pumps can also be used. According to one exemplary embodiment, with a clutch between the second prime mover and the hydraulic pump, the pump can be an inexpensive gear pump.

[0059] Yet another feature of one exemplary embodiment of the system is that a first rechargeable energy source connected to the second prime mover can be recharged in one or more modes. These modes include: the second prime mover using power from the first prime mover; the second prime mover using power from regenerative braking; the accessory, using energy stored in the second rechargeable energy source to operate the second prime mover; an auxiliary power unit connected to the first rechargeable energy source; an engine alternator, when present (the alternator can be increased in capacity to allow for this additional charge while driving or idle); or from an external power source, such as being directly plugged into an external power grid. The second prime mover can draw upon this power stored in the first rechargeable power source before daily operation of the vehicle (e.g., after overnight charging), when the vehicle is stopped, or in other situations. In such situations, the second prime mover would operate the accessory to pre-charge or pressurize the second rechargeable energy source before the energy is needed, which would provide higher density power storage when the second rechargeable power source is a hydraulic accumulator, among other advantages. A higher density energy storage device is intended to provide more available power at low revolutions per minute (RPM) operation and an overall lower mass system.

[0060] Various additional aspects and advantages will become apparent to those skilled in the art from the following detailed description of the embodiments.

[0061] Referring to FIGS. 1-20, hybrid vehicle drive systems according to several exemplary embodiments are

shown. Various features of these embodiments can be employed in other embodiments described herein.

[0062] As shown in FIG. 1, an exemplary embodiment of a hybrid vehicle drive system **10** can be employed on any type of vehicle. According to one embodiment, the vehicle can be any type of light, medium, or heavy duty truck. In one preferred embodiment, the vehicle is a truck that employs hydraulic systems such as a boom truck. Alternatively, the vehicle can be any type of platform where hybrid systems are employed. The vehicle may have a wide variety of axle configurations including, but not limited to a 4x2, 4x4, or 6x6 configuration.

[0063] In one preferred embodiment, the vehicle is a truck such as an International 4300 SBA 4x2 truck. According to one exemplary embodiment, the vehicle includes an IHC MaxxforceDT engine with an output of 255 HP and 660 lbs. of torque. The vehicle further includes an Allison 3500_RDS_P automatic transmission. The vehicle has a front gross axle weight rating (GAWR) of 14,000/12,460 lbs, a rear GAWR of 19,000/12,920 lbs., and a total GAWR of 33,000/25,480. The vehicle includes a hydraulic boom. The vehicle boom has a working height of approximately 54.3 feet, a horizontal reach of 36.0 feet, an upper boom has an extension of approximately 145 inches. The lower boom may travel between approximately 0 degrees and 87 degrees from horizontal. The upper boom may have a travel between approximately -20 degrees and 76 degrees from horizontal. According to an exemplary embodiment, the vehicle may further include a hydraulic platform rotator, a hydraulic articulating jib and winch (e.g., with a capacity of 1000 lbs.), a hydraulic jib extension, hydraulic tool outlets, an on-board power charger providing 5 kW at 240 VAC, and electric air conditioning with a capacity of 5,000 BTU. The above referenced power, boom, and types of components are exemplary only.

[0064] System **10** includes a first prime mover **20** (e.g., an internal combustion engine, such as a diesel fueled engine, etc.), a first prime mover driven transmission **30**, a component **40** (e.g., a power take-off (PTO), a transfer case, etc.), a second prime mover **50** (e.g., a motor, such as an electric motor/generator, a hydraulic pump with a thru-shaft, etc.), and an accessory **60** (e.g., a hydraulic pump, such as a variable volume displacement pump, etc.). In certain embodiments, accessory **60** can act as a third prime mover as described below. Transmission **30** is mechanically coupled to component **40**. Component **40** is coupled to second prime mover **50**. Second prime mover **50** is coupled to accessory **60**. According to one exemplary embodiment, second prime mover **50** is a 50 kW electric motor. When acting as a generator (as shown in FIGS. 3 and 4), second prime mover **50** may generate 30 kW continuously or as much as 75 kW at peak times. The above referenced power parameters are exemplary only. Second prime mover **50** may be further used to power various on-board components such as compressors, water pumps, cement mixer drums, etc.

[0065] In a preferred embodiment, accessory **60** is embodied as a hydraulic motor and includes a through shaft coupled to component **40** embodied as a PTO. The through shaft is also coupled to the shaft of the mover **50** embodied as an electric motor. In another embodiment, electric motor includes the through shaft that is coupled to the PTO and the pump.

[0066] According to one embodiment, system **10** also includes a first rechargeable energy source **70** (e.g., a battery, a bank of batteries, a fuel cell, a capacitive cell, or other

energy storage device), an Auxiliary Power Unit (APU) **80** (e.g., an internal combustion engine, possibly fueled by an alternative low emission fuel (e.g., bio-mass, natural gas, hydrogen, or some other fuel with low emissions and low carbon output), and a generator, a fuel cell, etc.), a second rechargeable energy source **90** (e.g. a hydraulic accumulator, ultra capacitor, etc.), and onboard or external equipment **100** (e.g., hydraulically operated equipment, such as an aerial bucket, etc.). First rechargeable energy source **70** is coupled to second prime mover **50** and provides power for the operation of second prime mover **50**. First rechargeable (e.g., pressurized or rechargeable) energy source **70** may include other auxiliary components (e.g., an inverter provided for an AC motor, a DC-to-DC converter to charge a DC system, an inverter for power exportation to a power grid or other equipment, controllers for motors, a charger, etc). APU **80** is coupled to first rechargeable energy source **70** and provides power to first rechargeable energy source **70**. According to one exemplary embodiment, second renewable energy source **90** is a hydraulic system with a high pressure portion (e.g., an accumulator) and a low pressure component (e.g., a reservoir tank).

[0067] Second rechargeable energy source **90** is coupled to accessory **60** and provides stored power for accessory **60**. Onboard or external equipment **100** can be coupled to accessory **60** or second rechargeable energy source **90** and operate using power from either accessory **60** or second rechargeable energy source **90**. In one embodiment, onboard or external equipment **100** is coupled through second rechargeable energy source **90** to accessory **60**. According to various exemplary embodiments, APU **80** may also provide power to both second renewable energy source **90** and first rechargeable energy source **70** when high hydraulic loads are required. APU **80** and second renewable energy source **90** may both provide power to hydraulically operated equipment **100**.

[0068] In one preferred embodiment, component **40** is a PTO designed to engage or disengage while the transmission is moving via a clutch mechanism. The PTO can be a street side or curb side PTO. Component **40** can be disengaged from transmission **30** when first prime mover **20** exceeds the maximum operating RPM of any component connected through component **40**. For example, component **40** can be disengaged if first prime mover **20** exceeds the maximum operating RPM of accessory **60**. Alternatively, all components connected through component **40** can operate throughout the RPM range of first prime mover **20**, and component **40** can be engaged continuously. In a preferred embodiment, component **40** can be disengaged during high speed steady driving conditions to reduce friction and wear on system **10**.

[0069] Alternatively, transmission **30** may be modified to incorporate component **40** and optionally incorporate second prime mover **50** directly into transmission **30**. Component **40**, embodied as a PTO, may optionally include a PTO shaft extension. An example of a PTO shaft extension is described in U.S. Pat. No. 6,263,749 and U.S. Pat. No. 6,499,548 both of which are incorporated herein by reference. Component **40** can have a direct connection to transmission **30**.

[0070] Component **40** may interface with transmission **30** in a way that there is a direct coupling between mover **20**, component **40**, and transmission **30**. Alternatively, component **40** may interface with transmission **30** in a way that the interface directly couples component **40** to the torque converter of transmission **30**. The torque converter may be in

mechanical communication with mover **20**, but rotating at a different speed or may rotate at the same speed as mover **20** if it is locked up.

[0071] A clutch mechanism can be employed to properly engage and disengage component **40**. In another preferred embodiment, component **40** is a PTO that has an internal clutch pack, such as a hot shift PTO. A hot shift PTO can be used when frequent engagements of the PTO are required, often with automatic transmissions. In one embodiment, second prime mover **50** can be operated at the same RPM as first prime mover **20** prior to the engagement of component **40**. This is intended to reduce wear on the clutch mechanism if component **40** has a 1:1 ratio of input speed to output speed. If other ratios for component **40** are used, the RPM of first prime mover **20** or second prime mover **50** can be adjusted accordingly prior to engagement to insure that input and output speed match the ratio of the component to reduce wear on the clutch mechanism.

[0072] While component **40** is engaged, second prime mover **50** can operate to provide power to a drive shaft **32** via transmission **30**.

[0073] In FIG. 1, first prime mover **20** provides power to drive shaft **32** through transmission **30**. Second prime mover **50** provides additional or alternative power to drive shaft **32** through component **40** and transmission **30**. Drive shaft **32** provides power to two or more wheels **33** used to provide forward and backward momentum to the vehicle. For example, second prime mover **50** can optionally provide the sole source of power to drive shaft **32**. Alternatively, second prime mover **50** can provide additional power to drive shaft **32** during vehicle acceleration. When providing power to drive shaft **32**, second prime mover **50** can operate using power from first rechargeable energy source **70**. According to the various exemplary embodiments of system **10**, first rechargeable energy source **70** can be charged or powered by second prime mover **50**, APU **80** or another suitable source (e.g., the vehicle alternator, the power grid, etc.).

[0074] Optional APU **80** can be used to power first rechargeable energy source **70** when the vehicle is driving up a grade, as well as other situations. This use is intended to improve vehicle performance, particularly when the power requirements of the vehicle exceed the power available from first prime mover **20**, first rechargeable energy source **70**, and second rechargeable energy source **90**. The presence of APU **80** is intended to allow for a smaller first prime mover **20**. In one embodiment, APU **80** is of a type that produces lower emissions than first prime mover **20**. APU **80** is intended to enable a vehicle using system **10** to meet various anti-idle and emission regulations.

[0075] In one embodiment, system **10** is configured to automatically engage APU **80** or first prime mover **20** through component **40** or accessory **60** to charge first rechargeable energy source **70** when the stored energy decreases to a certain amount. The permissible reduction in stored energy can be determined based upon a user selectable switch. The switch specifies the method of recharging first rechargeable energy source **70** from an external power grid.

[0076] In one embodiment, a user can select between 220-240V recharging, 110-120V recharging, and no external power source available for recharging. For the different voltages, the amount of power that can be replenished over a certain period of time (e.g., when connected to an external power grid overnight) would be calculated. Beyond that amount of power usage, first prime mover **20**, or APU **80** is

engaged to charge or provide power to first rechargeable energy source **70**. If no external power source is available, first prime mover **20** or APU **80** can be automatically engaged during regular finite periods, calculated to minimize idle time. In one embodiment, APU **80** and/or optionally first rechargeable energy source **70** can provide power to an external power grid **200**, also known as vehicle to grid (V2G) power sharing. This is intended to provide low-emission power generation and/or reduce requirements to generate additional grid power during peak loads on the grid.

[0077] In another embodiment, a user may only select between two settings, one setting to select charging using a grid and the other setting to select charging without using an external power grid. The controller would monitor state of charge of the batteries and control recharging differently for each setting. If no external charging from a power grid is selected, system **10** may allow the state of charge of first rechargeable energy source **70** (batteries) to drop to a threshold (as an example 30%), then the controller would cause either first prime mover **20** or the optional APU **80** to be engaged to charge batteries to a predetermined level (as an example 80%) to minimize the frequency that first prime mover **20** or APU **80** must be started. Or different levels of discharge and recharging may be selected to minimize idle time. System **10** may occasionally recharge batteries to 100% of charge to help condition the batteries. If the user selectable switch indicated system **10** would be charged from an external power grid, the controller may allow the state of charge of first renewable energy source to drop to a threshold (as an example 30%), then the controller would cause either first prime mover **20** or optional APU **80** to be engaged to charge batteries to a predetermined level that is lower (as an example 50%). The lower level allows the external power grid to recharge a greater amount of first rechargeable energy source **70** when vehicle can be plugged in or charged by the external power grid, reducing the fuel consumption of prime mover **70** or optional APU **80**.

[0078] External power grid **200** allows first rechargeable energy source **70** to be recharged with a cleaner, lower cost power compared to recharging first rechargeable energy source **70** with first prime mover **20**. Power from an external power grid may be provided at a fraction of the cost of power provided from an internal combustion engine using diesel fuel. According to one exemplary embodiment, first rechargeable energy source **70** can be recharged from an external power grid **200** in approximately 8 hours or less.

[0079] In one embodiment, second rechargeable energy source **90** is utilized, and provides power to accessory **60**. Additional or alternative power can be provided to drive shaft **32** by accessory **60**. For example, accessory **60** can provide power to drive shaft **32** until second rechargeable energy source **90** is discharged. Alternatively, accessory **60** can provide additional power to drive shaft **32** during vehicle acceleration. Accessory **60** provides power to drive shaft **32** through second prime mover **50**, component **40**, and transmission **30**. The combination of power provided to drive shaft **32** by second prime mover **50** and accessory **60** is intended to allow for the use of a smaller first prime mover **20** which provides the best use of stored energy and reduces the overall system mass. In another embodiment, accessory **60** only receives power from second prime mover **50** or from first prime mover **20** through component and does not provide power to drive shaft **32**. Accessory **60** may power equipment directly.

[0080] In one exemplary embodiment, an optional clutch can be coupled between first prime mover **50** and accessory **60** or between component **40** and second prime mover **50**. The clutch is disengaged when the vehicle is stationary so second prime mover **50** can turn accessory **60** without unnecessarily driving component **40**.

[0081] A variety of control systems can be utilized to control the various components (clutches, motors, transmissions, etc.) in system **10**. Electronic control systems, mechanical control systems, and hydraulic control systems can be utilized. In addition, a controller can be provided to indicate a request to operate an accessory or other equipment. In one embodiment, a controller similar to the controller in U.S. Pat. No. 7,104,920 incorporated herein by reference can be utilized. Preferably, the controller is modified to communicate by pneumatics (e.g., air), a wireless channel, or fiber optics (e.g., light) for boom applications and other applications where conductivity of the appliance is an issue.

[0082] The control system can utilize various input criteria to determine and direct the amount of power required or to be stored, the input criteria can input operator brake and acceleration pedals, accessory requirements, storage capacity, torque requirements, hydraulic pressure, vehicle speed, etc.

[0083] A control system may control the torque and power output of second prime mover **50** and accessory **60** so that component **40**, second prime mover **50** and accessory **60** are operated within the allowable torque and power limitations of each item so that the sum of second prime mover **50** and accessory **60** do not exceed component **40** or exceed capacity of transmission **30**, such as capacity of transmission power takeoff drive gear rating or exceed capacity of transmission maximum turbine torque on an automatic transmission. Optionally the controller may monitor and control additional input torque from the prime mover, or input torque of the prime mover after multiplication by the torque converter, along with that from other prime movers or accessories to ensure that the turbine torque limit is not exceeded or other internal torque ratings of components within an automatic transmission or an autoshift manual transmission, or a manual transmission. The torque and power output of second prime mover **50** and accessory **60** may also be controlled using an input from the driver and/or from a power train control system. If two components are used as described in other embodiments, the torque and power output of the second and third prime mover and optional accessory or accessories may be controlled so that the transmission power takeoff drive gear rating with two power takeoffs is not exceeded or that the capacity of transmission maximum turbine torque on an automatic transmission, or other torque rating of an internal component within a transmission of different kind, such as an autoshift manual or manual transmission is not exceeded.

[0084] According to other exemplary embodiments, a control system may be used for other purposes (e.g., coupling component **40** to transmission **30**; monitoring the charge status of first rechargeable energy source **70** and second rechargeable energy source **90**; monitoring and managing the thermal status of various components (e.g., prime movers, rechargeable energy sources, electronics, etc.); operating first prime mover **20**, second prime mover **50**, and accessory **60** to replenish energy in first rechargeable energy source **70** and second rechargeable energy source **90** and/or supply power to equipment **100**; operate APU **80** as needed; or control other functions). Information on the status of the system, such as

operating efficiency, status of rechargeable energy sources, and certain operator controls may be displayed or accessed by the driver.

[0085] Referring to FIG. 2, an exemplary operation of system 10 is shown. Component 40 is disengaged from transmission 30. APU 80 charges or provides power to first rechargeable energy source 70 when necessary. APU 80 can include a generator powered by an internal combustion engine. The generator can be connected to first rechargeable energy source 70 through a power converter, AC/DC power inverter or other charging system. First rechargeable energy source 70 provides power to second prime mover 50. The operation of second prime mover 50 operates accessory 60. Accessory 60 provides power to on-board or external equipment 100. First rechargeable energy source 70 and/or APU 80 may provide all the power for system 10 when the vehicle is stationary and first prime mover 20 is turned off (e.g., in an idle reduction system). If second prime mover 50 is not coupled to drive shaft 32 and instead provides power to accessory 60 (e.g., in an idle reduction system), system 10 may include a simplified control and power management system.

[0086] According to another exemplary embodiment, component 40 may be mechanically coupled to and first prime mover 20 may be operated periodically to provide power to second prime mover 50 through transmission 30 and component 40. Second prime mover 50 recharges first rechargeable energy source 70 and/or powers accessory 60. Accessory 60 can recharge second rechargeable energy source 90 or operate other equipment.

[0087] According to another exemplary embodiment, system 10 is configured as an idle reduction system that can provide power to vehicle loads such as HVAC, computers, entertainment systems, and equipment without the need to idle the engine continuously. Accordingly, system 10 uses an electric motor (e.g., prime mover 50) to power a hydraulic pump (e.g., accessory 60) for the operation of hydraulic equipment (e.g., aerial buckets, hydraulically powered compressors, etc.). Alternatively, the electric motor may directly power a compressor. The electric motor can be configured to only operate when there is a demand for hydraulic flow or the need to operate other mechanically coupled equipment to conserve energy within first rechargeable energy source 70. The electric motor can be activated by a controller that receives a signal sent through fiber optics or a signal sent through other means.

[0088] In one embodiment, mover 20 is not engaged with component 40 when mover 50 is used to power a pump or other mechanically coupled equipment 100. While component 40 (PTO) is not engaged, the PTO may be modified to allow shaft 32 to spin with low resistance. A PTO can be chosen with a feature that normally limits movement of the PTO when not engaged, this feature can be disabled when the electric motor is used to power the hydraulic pump. This concept also applies to "operating mode" for hybrid system process discussed below with reference to FIGS. 3 and 4. This type of idle reduction can be used when the vehicle is stationary.

[0089] Batteries (e.g., rechargeable energy source 70) provide energy for the electric motor. After the batteries are depleted, an external power grid is used to recharge the batteries.

[0090] If the rechargeable energy reserve is large enough, the electric motor (mover 50) may operate continuously, eliminating the need for a controller to turn motor on and off

based upon demand. Such a system may be coupled to a variable volume displacement pump to reduce flow when demand for hydraulic flow is low, resulting in lower consumption of power from the rechargeable energy source. This same method of continuous operation can also be used for hybrid system configurations.

[0091] Depending upon the battery system, the batteries may be thermally corrected during charging. Thermal correction may be needed if the temperature of the battery exceeds a certain threshold. A cooling system, either external to the vehicle or internal to the vehicle may be used, such that coolant is circulated to reduce heat or the battery case can be ventilated with cooler air to dissipate heat, possibly with a powered ventilation system. A second pump may also be connected to a PTO (as shown in FIG. 9). First prime mover 20 may be started and used to recharge by engaging component 40 to transmission and operating second prime mover 50 as a generator to recharge first rechargeable energy source batteries. If there is insufficient energy to operate the electric motor driven hydraulic pump, the vehicle engine is started, PTO engaged and the second pump is used to power the equipment. Further, the second pump can be used when the hydraulic power requirements exceed the power output of the electric motor coupled to the hydraulic pump. Alternatively, prime mover 50 could directly power the first accessory (hydraulic pump) and the second prime mover could be made not to operate as a generator. Not operating second prime mover as a generator may reduce system complexity and reduce cost.

[0092] In another embodiment, first rechargeable energy source 70 provides power to electrical systems of the vehicle such as "hotel loads" (e.g., HVAC, lighting, radio, various electronics, etc.). In yet another embodiment, first rechargeable energy source 70 charges a main crank battery of the vehicle. The main crank battery can be isolated from system 10. First rechargeable energy source 70 may also be used in other configurations that use 100% electric propulsion for certain periods to power additional vehicle systems such as power steering, brakes and other systems normally powered by first prime mover 20.

[0093] In yet another embodiment, second prime mover 50 provides power to external devices directly or through an additional rechargeable energy source and an associated inverter. Utilizing second prime mover 50 to power external devices is intended to lessen the need for an additional first prime mover 20 powered generator.

[0094] In yet another embodiment, a sophisticated control system (e.g., a pump control system utilizing fiber optics, etc.) can be used to control the operation of accessory 60. In yet another embodiment, accessory 60 is a variable volume displacement pump. Accessory 60 can operate continuously, only providing flow if there is a demand. When no demand is present, accessory 60 provides little or no additional friction or resistance within the system.

[0095] Referring to FIG. 3, another exemplary operation of system 10 is shown. First rechargeable energy source 70 and/or APU 80 may provide power for system 10 when the vehicle is stationary and first prime mover 20 is turned off (e.g., in an idle reduction system). For example, as shown in FIG. 3, energy source 70 may power accessory 60. In one embodiment, second rechargeable energy source 90 is utilized. Accessory 60 stores energy in second rechargeable energy source 90, as shown. Second prime mover 50 is engaged to operate accessory 60 (e.g., a hydraulic pump)

when the stored energy in second rechargeable energy source **90** (e.g., a hydraulic accumulator) is reduced to a predetermined level. The utilization of second rechargeable energy source **90** is intended to reduce operation time of accessory **60**. Accessory **60** only needs to operate to maintain energy in second rechargeable energy source **90**. On-board or external equipment **100** (e.g., any hydraulic equipment) is powered by second rechargeable energy source **90**. In one embodiment, a clutch mechanism is used to disengage accessory **60** from second prime mover **50** during vehicle travel when second rechargeable energy source **90** has been fully charged. This is intended to reduce friction on system **10** when second prime mover **50** is needed, but accessory **60** is not. Second rechargeable energy source **90** can provide hydraulic power to equipment **100** at a constant system pressure through a pressure reducing valve.

[0096] Alternatively, second rechargeable energy source **90** and two hydraulic motor/pump units are coupled together to provide constant system pressure and flow. The first unit (e.g., a hydraulic motor) receives high pressure flow from second rechargeable energy source **90**. The first unit is coupled to a second unit (e.g., a pump) which supplies hydraulic power to equipment **100** at a lower pressure. Both hydraulic second rechargeable hydraulic circuit and low pressure hydraulic equipment circuit have a high pressure and a low pressure (reservoir or tank) sections. A control system may be utilized to maintain constant flow in the low pressure hydraulic equipment circuit as the high pressure flow from the second rechargeable source (accumulator) reduces or varies. The advantage of this configuration is that the energy from the high pressure accumulator is more efficiently transferred to the equipment. This configuration also allows independent hydraulic circuits to be used for the propulsion system and for equipment **100**. The independent hydraulic circuits allow for fluids with different characteristics to be used in each circuit. Further, a hydraulic circuit that may be susceptible to contamination (e.g., the equipment circuit) can be kept separate from the other hydraulic circuit (e.g., the propulsion circuit).

[0097] In another embodiment, second rechargeable energy source **90** is utilized, and accessory **60** is a hydraulic pump. Second rechargeable energy source **90** can include a low pressure fluid reservoir and a hydraulic accumulator. The utilization of second rechargeable energy source **90** obviates the need for a sophisticated pump control system and the associated fiber optics; instead a simpler hydraulic system can be used (e.g., an insulated aerial device with a closed center hydraulic system and a conventional control system, etc.). If the speed of accessory **60** slows due to depletion of on-board power sources, accessory **60** can operate longer to maintain energy in second rechargeable energy source **90**. This is intended to minimize any negative effects on the operation of equipment **100**. According to one exemplary embodiment, second prime mover **50** is an AC motor and turns at generally a constant rate regardless of the output volume of accessory **60** (e.g., to create two or more different levels of flow from accessory **60**).

[0098] However, in some scenarios, second prime mover **50** may provide power to accessory **60** and the speed of second prime mover **50** may be varied by a controller. For example, the speed of second prime mover **50** may be varied to reduce the flow of fluid from accessory **60** (e.g., for two speed operation of an aerial device where lower hydraulic flow may be desirable for fine movement of the boom).

[0099] In one embodiment, system **10** can provide the advantage of allowing a vehicle to operate at a work site with fewer emissions and engine noise by using an operating mode. In an operating mode (as shown in FIGS. **3** and **4**), first prime mover **20** (e.g., an internal combustion engine, such as a diesel fueled engine, etc.) is turned off and component **40** (PTO) is disengaged from transmission **30**, and component **40** when disengaged is able to spin freely with little resistance, and power from first renewable energy source **70** and second renewable energy source **90** are used to operate on-board or external equipment **100** and electrical systems of the vehicle such as “hotel loads” (e.g., HVAC, lighting, radio, various electronics, etc.). According to another exemplary embodiment, second renewable energy source **90** may be optional and first renewable energy source **70** may directly supply power to equipment **100**. According to one exemplary embodiment, first renewable energy source **70** has a capacity of approximately 35 kWh and is configured to provide enough power to operate the vehicle for a full day or normal operation (e.g., 8 hours).

[0100] Referring to FIG. **4**, yet another exemplary operation of system **10** is shown. When APU **80** is out of fuel, APU **80** is not used, or APU **80** is not present, first rechargeable energy source **70** can be recharged by other components of system **10** (in addition to other methods). First prime mover **20** and second prime mover **50** are preferably operated and synchronized to the same speed (e.g., input and output mechanical communication through component **40** is a one to one ratio). Component **40** is preferably engaged to transmission **30**. First prime mover **20** provides power to second prime mover **50** through transmission **30** and component **40**. Adjustments to second prime mover **50** speed is made if the ratio between first prime mover **20** and second prime mover **50** is not one to one to minimize wear of the clutch in component **40** or to speed of first prime mover **50**. Operation of second prime mover **50** recharges first rechargeable energy source **70** to a predetermined level of stored energy. This method of recharging first rechargeable energy source **70** is intended to allow continuous system operation in the field without the use of external grid power. This method is further intended to allow continuous operation of equipment **100** during recharging of first rechargeable energy source **70**.

[0101] While charging first rechargeable energy source **70**, second prime mover **50** simultaneously operates accessory **60**. Accessory **60** provides power to on-board or external equipment **100**. After first rechargeable energy source **70** has been recharged, component **40** is disengaged from transmission **30**. Operation of accessory **60** can continue without the use of first prime mover **20** as shown in FIG. **2**. Alternatively, with component **40** engaged, operation of accessory **60** can continue powered in part or in full by prime mover **20**. This may be useful for example, if there is a failure in one of the other components that powers accessory **60**. This may also be useful if the power demand from accessory **60** exceeds the power available from second prime mover **50**. According to one exemplary embodiment, first prime mover **20** provides supplementary power to or all of the power to equipment **100** (e.g. a digger derrick that may require higher hydraulic flow during digging operations). Using first prime mover **20** to provide supplementary power to equipment **100** during intermittent periods of high power requirement allows system **10** to include a smaller second prime mover **50** that is able to provide enough power for the majority of the equipment operation. The control system may receive a signal from the

equipment indicating additional power is required beyond that provided by second prime mover 50. Such a signal may be triggered by the operator, by activation of a function (e.g., an auger release, etc.), by demand in the circuit or component above a predetermined threshold, or by other means.

[0102] Referring to FIG. 5, yet another exemplary operation of system 10 is shown. Second rechargeable energy source 90 is utilized. Accessory 60 provides power to second rechargeable energy source 90. In one embodiment, on-board or external equipment 100 (e.g., hydraulic cylinders, valves, booms, etc.) is coupled to second rechargeable energy source 90, and can be powered by second rechargeable energy source 90. External equipment 100 may also be operated directly by accessory 60 without the use of a second rechargeable energy source 90. This method of recharging first rechargeable energy source 70 and second rechargeable energy source 90 is intended to allow continuous system operation in the field without the use of external grid power. This method is further intended to allow continuous operation of equipment 100 during recharging of first rechargeable energy source 70 and second rechargeable energy source 90.

[0103] Referring to FIG. 6, yet another exemplary operation of system 10 is shown. In one embodiment, a clutch or other mechanism is used to disengage first prime mover 20 from transmission 30 during vehicle braking. This is intended to maximize the regenerative energy available from vehicle braking. The forward momentum of the vehicle provides power from wheels 33 to transmission 30. Transmission 30 may be reduced to a lower gear to increase the RPMs and increase the amount of energy transferred to second prime mover 50. Second prime mover 50 can operate to charge first rechargeable energy source 70 and help slow the vehicle according to principles of regenerative braking. Disengaging first prime mover 20 from transmission 30 further reduces the amount of energy transferred back to first prime mover 20 during braking and reduces the need for engine braking. The control system for the hybrid components may also monitor chassis anti-lock brake system (ABS) activity. If the chassis anti-lock brake system has sensed possible wheel lock-up and has become active, possibly due to low traction or slippery road conditions, then hybrid regenerative braking is suspended by the hybrid control system. The regenerative braking system may be disabled as soon as ABS is active and may remain off for only as long as the ABS is active, or alternatively regenerative braking may remain off for a period of time after ABS is no longer active or regenerative braking may remain off for the remainder of the ignition cycle to eliminate the chance that regenerative braking could adversely affect vehicle handling in low friction, slippery road conditions during the current ignition cycle. At the next ignition cycle, regenerative braking may be reactivated.

[0104] Referring to FIG. 7, yet another exemplary operation of system 10 is shown. Second rechargeable energy source 90 is utilized. As mentioned above, during vehicle braking, first rechargeable energy source 70 is charged through operation of second prime mover 50. Accessory 60 can operate to further slow the vehicle, and store energy in second rechargeable energy source 90, if second rechargeable energy source 90 is not fully charged. In this manner, regenerative braking can be used to simultaneously charge multiple energy storage devices of system 10. This is intended to allow recharging of both energy storage devices through braking during vehicle travel, among other advantages. A clutch can

be optionally included between first prime mover 20 and transmission 30 to further improve regenerative braking.

[0105] Referring to FIG. 8, in an alternative embodiment of system 10, component 40 is a transfer case. Component 40 is coupled to transmission 30, drive shaft 32, and second prime mover 50. Energy from regenerative braking bypasses transmission 30, passing through component 40 to operate second prime mover 50. Similarly, motive power for drive shaft 32 from second prime mover 50 and accessory 60 bypasses transmission 30, passing through component 40. Component 40 further allows power from second prime mover 50 to be transferred to drive shaft 32, assisting, for example, when the vehicle is accelerating. A conventional clutch can be placed between drive shaft 32 and component 40 to disconnect drive shaft 32 when the vehicle is parked and to allow second prime mover 50 to charge first rechargeable energy source 70 when transmission 30 is coupled to component 40 and first prime mover 20 is coupled to transmission 30. An optional clutch can also be placed between component 40 and transmission 30 or between transmission 30 and first prime mover 20. This allows power from regenerative braking to be channeled directly to second prime mover 50 and accessory 60.

[0106] In one embodiment, during operation of equipment 100, component 40 is not coupled to second prime mover 50 and accessory 60 can optionally directly power equipment 100. An optional APU 80 can charge first rechargeable energy source 70 and/or second rechargeable energy source 90 as required.

[0107] Referring to FIG. 9, in an alternative embodiment of system 10, a second component 110 such as a power take-off (PTO) is coupled to the transmission 30. Accessory 60 may be a hydraulic pump with the capability to produce more power than a single power take-off can transfer to transmission 30. First component 40 and second component 110 are provided to cooperate to transfer more power from second rechargeable energy source 90 to transmission 30 than a single component is able to transfer. System 10 further includes a third prime mover 120 (e.g., a motor, such as an electric motor/generator, etc.), and a second accessory 130 (e.g., a hydraulic pump, such as a variable volume displacement pump, etc.). Transmission 30 is mechanically coupled to components 40 and 110. Second component 110 is coupled to third prime mover 120. Third prime mover 120 is coupled to second accessory 130. First rechargeable energy source 70 is coupled to third prime mover 120 and provides power for the operation of third prime mover 120. Second rechargeable energy source 90 is coupled to second accessory 130 and provides stored power for second accessory 130. While FIG. 9 shows a system 10 with both third prime mover 120 and second accessory 130 coupled to second component 110, according to other exemplary embodiments, either third prime mover 120 or second accessory 130 may be absent. If a clutch is provided between first prime mover 20 and transmission 30, first component 40 and second component 110 may be configured to drive transmission 30, possibly without assistance from prime mover 20 or when prime mover 20 is off. At slow speeds, if transmission 30 includes a torque converter which is not locked, the optional clutch may not be needed for components 40 and 110 to transfer power to transmission 30 and move the vehicle.

[0108] In an alternative embodiment of system 10 for FIG. 9, an external power grid can be used with an electrical rechargeable energy source. Battery size and system software can be modified to charge the battery in the electric grid. For

example, the software can be modified to use a charge depleting mode if the battery is charged from the grid.

[0109] Referring to FIG. 10, in an alternative embodiment of system 10, a high horsepower prime mover 140 (e.g., a motor such as a high output power hydraulic motor, etc.) is coupled to second component 110. High horsepower prime mover 140 is further coupled to second rechargeable energy source 90 (e.g., one or more accumulators). Second rechargeable energy source 90 is pressurized by accessory 60 during highway speeds or while parked.

[0110] In one embodiment, high horsepower prime mover 140 receives power from a PTO to pressurize second rechargeable energy source 90 during regenerative braking. Conversely, mover 140 can aid acceleration of the vehicle through component 110 and transmission 30. A clutch can be disposed between first prime mover 20 and transmission 30 for more efficient regenerative braking. The embodiment of system 10 shown in FIG. 10 may include a system including second rechargeable energy source 90 and two hydraulic motor/pump units that is configured to provide constant system pressure and flow similar to the system described above. The first unit or high pressure motor is provided by high HP prime mover 140. The second unit or low pressure pump (e.g., a variable displacement pump pressure compensated load sensing pump) may be provided between high HP prime mover 140 and second component 110 preferably with a through shaft or other means of mechanical communication. The equipment circuit can trigger operation of high HP prime mover 140.

[0111] Referring to FIG. 11, in an alternative embodiment of system 10, a high power prime mover 140 is coupled to second component 110. High horsepower prime mover 140 is further coupled to an ultra capacitor 150 (e.g., a fast charge and discharge capacitor, etc.) which may include multiple capacitors. Capacitor 150 is in turn coupled to first rechargeable energy source 70. First rechargeable energy source 70 is charged by second prime mover 50 during highway speeds or while parked, by auxiliary power unit 80 or by being plugged into the electrical power grid. High HP prime mover 140 may also independently recharge first rechargeable energy source 70. In an optional charging scheme, APU 80 is optional.

[0112] Referring to FIG. 12, in an alternative embodiment of system 10, a second accessory 130 (e.g., a hydraulic pump, such as a variable volume displacement pump, etc.) and a high horsepower prime mover 140 (e.g., a motor such as a high power electric motor, etc.) are coupled to first prime mover 20 (e.g., to the crankshaft of an internal combustion engine, such as a diesel fueled engine, etc.). Second accessory 130 and high horsepower prime mover 140 allow large amount of power to be transmitted to first prime mover 20. First rechargeable energy source 70 is coupled to high horsepower prime mover 140 via capacitor 150 and provides power for the operation of high horsepower prime mover 140. Second rechargeable energy source 90 is coupled to second accessory 130 and provides stored power for second accessory 130. High horsepower prime mover 140 may further be used to assist in cranking first prime mover 20. Cranking first prime mover 20 may be particularly advantageous when first prime mover 20 is started and stopped frequently (e.g., to reduce idle time). High horsepower prime mover 140 may further be a more powerful starter motor. While FIG. 9 shows a system 10 with both second accessory 130 coupled to second component 110 and high horsepower prime mover 140, according to

other exemplary embodiments, either second accessory 130 may be absent or horsepower prime mover 140 may be absent.

[0113] Referring to FIG. 13, in an alternative embodiment of system 10, includes a first prime mover 20 (e.g., an internal combustion engine, such as a diesel fueled engine, etc.), a first prime mover driven transmission 30, a component 40 (e.g., a power take-off (PTO), a transfer case, etc.), a second prime mover 50 (e.g., a motor, such as an electric motor/generator, a hydraulic pump with a thru-shaft, a hydraulic pump without a thru-shaft with second prime mover 50 only connected on one side etc.), and an accessory 60 (e.g., a hydraulic pump, such as a variable volume displacement pump, a hydraulic pump with a thru-shaft etc.). Transmission 30 is mechanically coupled to component 40. Component 40 is coupled to accessory 60. Accessory 60 is coupled to second prime mover 50.

[0114] According to one exemplary embodiment, accessory 60 is a hydraulic pump with a thru-shaft. Coupling the accessory 60 to the component 40 provides several advantages. Hydraulic pumps with thru-shafts are more common and generally less expensive than thru-shaft motors. Further, accessory 60 is generally smaller than second prime mover 50 and allows for a more compact package when coupled to component 40.

[0115] Second rechargeable energy source 90 is coupled to accessory 60 and provides stored power for accessory 60. Accessory 60 stores energy in second rechargeable energy source 90 during the operation of system 10 (e.g., during cruising or during regenerative braking, etc.). Accessory 60 may draw energy from second rechargeable energy source 90 to provide bursts of high horsepower to first prime mover 20 until second rechargeable energy source 90 is exhausted. In another embodiment, accessory 60 may directly power equipment and second rechargeable energy source 90 may be absent.

[0116] Referring to FIG. 14, in an alternative embodiment, system 10 may include a clutch 160 coupled to component 40. As described earlier component 40 may be a PTO with an integral clutch to selectively disconnect component 40 from first prime mover 20. However, even when disconnected from first prime mover 20, component 40 may still be powered by second prime mover 50 and/or accessory 60. The rotational inertia of component 40 along with any associated frictional losses represent power that is wasted in component 40. Optional clutch 160 allows component 40 to be disengaged from second prime mover 50 and/or accessory 60. Auxiliary Power Unit 80 is optional. Accessory 60 may directly power equipment 100. Source 90 is optional. Optional clutch 160 could be used in other configurations where it would be advantageous to completely remove component 60 from second prime mover 80 or accessory 60.

[0117] Referring to FIG. 15, in an alternative embodiment, system 10 may include a clutch 165. System 10 as shown in FIG. 15 operates similar to the embodiment of FIG. 10 and includes an accessory 60 (e.g., a hydraulic pump, such as a variable volume displacement pump, etc.) coupled to component 40. Similar to high horsepower prime mover 140 shown in FIG. 10, accessory 60 may be configured to provide a large amount of power to transmission 30 to augment first prime mover 10. For example, accessory 60 may transfer additional power to transmission 30 to facilitate accelerating the vehicle. Accessory 60 may operate with or without an electrical motor as shown in FIG. 10.

[0118] Clutch 165 is coupled to first prime mover 20 and transmission 30. Clutch 165 is configured to selectively disengage first prime mover 20 from transmission 30. The rotational inertia of first prime mover 20 along with any associated frictional losses represent energy that is wasted in first prime mover 20 and reduces the efficiency of regenerative braking in system 10. Disengaging first prime mover 20 from the rest of system 10 allows for more energy to be captured during regenerative braking.

[0119] Referring to FIG. 16, in an alternative embodiment, system 10 may include both a first component 40 such as a PTO, and a second component 110 such as a transfer case coupled to transmission 30. Similar to the embodiment of FIG. 8, energy from regenerative braking bypasses transmission 30, passing through component 110 to operate accessory 60. Similarly, motive power for drive shaft 32 from accessory 60 bypasses transmission 30, passing through component 110. Component 110 further allows power from accessory 60 to be transferred to drive shaft 32, assisting, for example, when the vehicle is accelerating. Transmission 30 is further mechanically coupled to component 40. Component 40 is coupled to second prime mover 50. Using both a PTO and a transfer case allows system 10 to benefit from better regenerative braking from drive shaft and the inclusion of a PTO to power electric motor operated hydraulic equipment. Second prime mover 50 may provide power to a second accessory 65 to pressurize second rechargeable energy source 90 when the vehicle is parked or moving at a constant speed. Second rechargeable energy source 90 provides additional power during the acceleration of the vehicle. System 10 may optionally include a clutch between first prime mover 20 and transmission 30 and/or between transmission 30 and component 110.

[0120] As shown in FIG. 16, system 10 may further include a third component 180 such as a PTO, a third prime mover 190, and a fourth prime mover 195. Third prime mover 190 is coupled to third component 180. Third prime mover 190 is coupled to first rechargeable energy source 70 configured to charge first rechargeable energy source 70. In this way, second prime mover 50 may draw power from first rechargeable energy source 70 while first rechargeable energy source 70 continues to be charged by third prime mover 190. Fourth prime mover 195 may be a larger starter motor and may be provided for first prime mover 20 to assist with low speed torque and quick starts of first prime mover 20. The large starter motor can also reduce unnecessary idle. First prime mover 20 may be started and stopped to reduce unnecessary idling. Mover 195, mover 190, and component 180 are optional. Clutches can be placed between mover 20 and transmission 30 and between transmission 30 and component 110. The interface between mover 50 and accessory 65 can be by a one way or two way interface.

[0121] Referring to FIG. 18, in an alternative embodiment, system 10 may include both a first component 40 and a second component 110 such as a PTO coupled to transmission 30, and a third component 210 such as multi-input/output drive coupled to first component 40 and second component 110. Third component 210 may be a hydraulic drive such as manufactured by Funk Manufacturing Co. and distributed by Deere & Company. Third component is further coupled to a second prime mover 50. Second prime mover 50 may be an electric motor with the capability to produce more power than a single power take-off can transfer to transmission 30. First component 40, second component 110, and third component 210 are

provided to cooperate to transfer more power from second prime mover 50 to transmission 30 than a single component is able.

[0122] Referring to FIG. 19, in an alternative embodiment, system 10 may include both a first component 40 and a second component 110 such as a PTO coupled to transmission 30. System 10 further includes a second prime mover 50 (e.g., a motor, such as an electric motor/generator, etc.), and a third prime mover 220 (e.g., a motor, such as an electric motor/generator, etc.), coupled to first component 40 and a second component 110, respectively. A first rechargeable energy source 70 is coupled to second prime mover 50 and third prime mover 220 and provides power for the operation of second prime mover 50 and a third prime mover 220.

[0123] Clutch 165 can disengage first prime mover 20, allowing the vehicle to be driven in an all electric mode if other vehicle systems (e.g., HVAC system, braking, power steering, etc.) are also electrically driven. The all electric mode may also be possible in other system configurations (as shown in FIG. 6). The all electric mode saves fuel by allowing first prime mover 20 to be off when not needed such as at low speeds or when the vehicle is stopped.

[0124] Optionally, transmission 30 may be constructed such that independent component input/output gears are used, one for each component 40 and 110. A clutch located in transmission 30 and in between input/output gears for components 40 and 110 could allow series/parallel operation by operating first prime mover 20, engaging clutch 165 and driving one of the component input/output gears causing either second prime mover 50 or third prime mover 220 to act as a generator. In one example, the clutch in transmission 30 disengages one component input/output gear from the other component input/output gear that interfaces with prime mover 50 acting as a generator. The remaining component input/output gear is coupled to the other gears in transmission 30 that transmit power to drive shaft 32, possibly through another clutch internal to the transmission that is engaged. The remaining prime mover acts as a motor and powers transmission 30 through the component that is mechanically coupled to the input/output gear. Such an arrangement is particularly useful when the vehicle is driven in the city. In such a situation, prime mover 20 may operate at a more efficient speed and power range, independent of vehicle speed, or prime mover 20 may be turned off completely to further reduce fuel consumption. If more power is needed, the disengaged prime mover may be synchronized in speed with the disengaged prime mover or prime movers 20 and then also coupled to transmission 30 to provide the needed additional power. The engaged prime mover or transmission, making adjustments in speed to adapt to the ratio of the input to output gearing of the component (PTO).

[0125] Alternatively, an optional APU could charge first rechargeable energy source 70 while first prime mover 20 is kept off and the vehicle is operated in a series hybrid configuration in which clutch 165 is disengaged. The APU is preferably a low emissions power source using a low carbon fuel. Such a configuration would be useful in an urban area requiring low emissions. As in the all-electric mode, vehicle systems (e.g., HVAC, braking, power steering, etc.) are operated electrically when first prime mover 20 is off and the vehicle is being driven.

[0126] Referring to FIG. 20, in an alternative embodiment, system 10 may be similar to the embodiment shown in FIG. 1. However, second prime mover 50 (e.g., a motor, such as an

electric motor/generator, etc.) may provide more power than necessary to drive accessory 60 (e.g., a hydraulic pump, such as a variable volume displacement pump, etc.). Therefore, a third prime mover 230 such as a smaller electric motor/generator is provided. Third prime mover 230 is coupled to first rechargeable energy source 70 and provides power to accessory 60. According to one exemplary embodiment, third prime mover 230 is a 10-60 hp electric motor, more preferably a 20-40 hp electric motor.

[0127] Referring to FIG. 21, in an alternative embodiment, system 10 may be similar to the embodiment shown in FIG. 1. However, a fourth prime mover 240 may be coupled to first prime mover 20 with a clutch 245 (e.g., to the crankshaft of the internal combustion engine). The coupling may be direct to the crankshaft or through a belt or through a shaft. Fourth prime mover 240 may be, for example, an electric motor that provides power to one or more accessories 250 such as a cooling fan for first prime mover 20, power steering pumps, an HVAC system, brakes, etc. Alternatively, it may be an integrated starter generator, optionally capable of regenerative braking.

[0128] System 10 as shown in FIG. 21, is able to function in several modes, depending on the needs of the vehicle. System 10 can be configured as a combination series/parallel hybrid. For example, in an all electric mode, first prime mover 20 may be turned off and clutch 165, disengaged prime movers 50 and 220 may provide the power to drive wheels 33. Movers 50 and 220 can be attached to a hydraulic pump. In one embodiment, movers 50 and 220 can be integrated with a hydraulic pump as a single unit sharing a shaft. According to one exemplary embodiment, each of prime movers 50 and 220 are able to provide at least 100 hp so that 200 hp of power are transmitted to transmission 30 to drive wheels 33. If the vehicle requires more power to drive shaft 32, first prime mover 20 may be turned on. The speed of the output from first prime mover 20 is synchronized to the desired RPMs. Clutch 165 is engaged to couple first prime mover 20 to transmission 30 in addition to prime movers 50 and 220. If the vehicle requires even more power to drive shaft 32, clutch 245 may be engaged so that fourth prime mover 240 provides additional power to crankshaft of first prime mover 20. Fourth prime mover 240 may simultaneously provide power to one or more accessories 250. Using prime movers 50, 220 and 240 to supplement the power driving wheels 33 allows a smaller, more efficient first prime mover 20 to be used in system 10.

[0129] Fourth prime mover 240 can drive accessories 240 via belts and/or pulleys and/or shafts and/or gears can be mechanically coupled to first prime mover 20 through clutch 245 via belts, shafts, gears and/or pulleys. Prime mover 240 can be an electric motor with a through shaft. The through shaft can drive belts and/or pulleys for accessories (e.g., HVAC, fan, steering, pumps, brakes, etc.) Clutch 165 may be integrated with the transmission (as in a manual transmission or in an auto-shift transmission). In an automatic transmission utilizing a torque converter, clutch 165 may be in between the torque converter and the ICE or integrated into the transmission and placed between the torque converter and the input gear for the PTO (for those transmissions that utilize a PTO input gear independent of the torque converter). The integration and/or location of clutch 165 as described may be used for other embodiments shown in other diagrams in which a clutch can be placed in between the ICE and the transmission.

[0130] If first prime mover 20 is a relatively small internal combustion engine, it may not be able to provide all the power

to drive wheels and regenerate rechargeable energy source 70. In such a case, clutch 165 is disengaged and clutch 245 is engaged so that first prime mover 20 only drives accessories 250 and third prime mover 240 which, in turn, acts as a generator to charge rechargeable energy source 70. Prime movers 50, and 220 provide power to drive wheels 33. This arrangement allows first prime mover 20 operate in a more efficient zone. Clutch 245 may disconnect first prime mover 20 from fourth prime mover 240 and fourth prime mover 240 may provide power for accessories 250. To keep the engine block warm when first prime mover 20 is turned off, engine coolant may be circulated through a heating element (not shown). The ICE can then be turned off to eliminate fuel consumption and reduce emissions if first rechargeable energy source has enough energy to power other prime movers. As with all hybrid mechanizations described, a control system would assess various inputs to the system and adjust output of various devices, for example monitoring factors such as, energy levels, power demand, torque, control inputs, speeds, temperatures and other factors to determine appropriate operation of prime movers, activation of clutches and other devices for optimal efficiency and performance. The heated coolant would then be circulated back to first prime mover 20. The heated coolant may also be used to warm rechargeable energy source 70 or other on-board batteries when the ambient air is cold. The warmer for the engine block and/or batteries could be used on other embodiments.

[0131] System 10 as illustrated in FIG. 21 advantageously can utilize a parallel hybrid configuration with assist from fourth prime mover 240 (e.g., accessory electric motor), first prime mover 20 (ICE), second prime mover 50, and third prime mover 220. The parallel nature of system 10 allows maximum acceleration as power can be utilized from multiple sources. As discussed above, transmission 30 can include a clutch (e.g. internal or external clutch 165). To reduce clutch wear, components 40 and 110 can be utilized to launch the vehicle and once the input shaft is close to or at the same speed as the engine drive shaft, the clutch can be engaged to couple prime mover 20 to transmission 30. This method can also be used for other embodiments in which a clutch is used to engaged the prime mover with the transmission.

[0132] Alternatively, system 10 in FIG. 21 can be provided as only a single PTO system. The use of two PTOs allows more power to be provided to transmission 30.

[0133] Accordingly to another embodiment, system 10 of FIG. 21 can be arranged so that a parallel hybrid configuration is assisted from mover 220 and mover 50 during acceleration. In an electric only acceleration mode, power can be provided through components 40 and 110 via motors 50 and 220 with prime mover 20 off.

[0134] Fourth prime mover 240 can be a multitude of electric motors for powering individual accessories. Clutch 245 and mover 240 can be connected to the front or other locations of prime mover 20 and could be used in other configurations with reference to FIGS. 1-20. Advantageously, electric only acceleration can use standard drive train components and does not produce emissions. The use of prime mover 240 powered through source 70 for movers 220 and 50 reduces emissions.

[0135] According to another embodiment, system 10 as illustrated in FIG. 21 can also be configured to provide series electric only acceleration. Mover 20 is used to charge first rechargeable energy source 70 (e.g., batteries) and is not directly coupled to transmission 30 or is disconnected from

transmission 30 via clutch 165. Mover 240 provides power to accessories 250. Advantageously, mover 20 can be configured to operate at most efficient RPM and load. Preferably, motor 240, has a thru-shaft and can act as a generator while mover 20 powers accessories. Such a system would have advantages in stop and go type applications where electric motors can store energy during braking and accelerate vehicle without having to change the operating RPM of mover 20.

[0136] According to another embodiment, system 10 as illustrated in FIG. 21 can also be operated in a ICE only cruise mode. During steady driving (such as highway driving), ICE prime mover (e.g., mover 20) may provide all of the power and electric motors (e.g., movers 220 and 50) may be uncoupled (disconnected via clutches) from the drive train to reduce unnecessary friction and parasitic loads. Such mode provides best constant power at cruising speeds. In such a mode, mover 20 can be directly coupled or coupled through clutch 165 to transmission 30 to provide best efficiency when mover 20 (ICE) can operate at a steady state and in an efficient RPM and load range. All unnecessary hybrid components can be disconnected during ICE only cruise mode, as well as any unnecessary loads. When accelerating or braking, electric motors (or hydraulic motors) may be temporarily engaged to provide additional propulsion or capture brake energy for reuse resulting in higher operating efficiency and lower fuel consumption.

[0137] According to yet another embodiment, system 10 as illustrated in FIG. 21 can also be provided in a mode in which highway speed is maintained by mover 20 and hybrid components are temporarily engaged to accelerate or slow the vehicle. An ICE (mover 20) can be used for base cruise power and one or more electric or hydraulic motors are engaged as needed for additional acceleration or to slow the vehicle. After the vehicle resumes a steady highway cruise, components 110 and 40 (e.g., PTOs) can be disengaged to remove unnecessary resistance of unneeded hybrid components. Advantageously, such a configuration allows a smaller horsepower engine to be used in optimal range for maximum efficiency and reduces large swings required in outputs from mover 20 (e.g., the engine operates less efficiently when required to provide power to provide large transient loads or when power output is much higher or lower than its optimal range).

[0138] According to an alternative embodiment, mover 50 can include a pump or a pump can be placed in between mover 50 and first component 40. In another alternative, the hydraulic pump could be placed after or behind mover 50. In this embodiment, power from source 70 can be utilized to drive pump for hydraulic components using mover 50. Such configuration would be advantageous when the vehicle is stationary as power from the batteries (e.g., source 70) is utilized to operate electric motors and hydraulic pumps.

[0139] According to another embodiment, system 10 illustrated in FIG. 21 can be operated in a mode in which mover 20 is operated and the rotational speed of the hydraulic pump is constant. Component 40 can be engaged so that mover 20 drives the hydraulic pump and mover 50. If rotation of mover 50 needs to vary due to changes in required hydraulic flow, a separate PTO can be engaged and used to recharge batteries while other electric motors can operate independently to provide power to the pump with varying rotation speed. As discussed above, the hydraulic pump can be placed between mover 50 and component 40 or behind mover 50. In an embodiment in which a second PTO is not available, the

rotational speed of the pump can be kept constant and the output of the pump can be varied to change flow to meet required hydraulic flow variations. This configuration is particularly advantageous in digger derrick applications in which the speed of the auger must be changed by adjusting flow.

[0140] Referring to FIGS. 22-29, in an alternative embodiment, system 10 may be similar to the embodiment shown in FIG. 21. However, a fifth prime mover 260 with a clutch 255 may be provided between first prime mover 20 and clutch 165. Fifth prime mover 260 may act as a motor to power the drive train or as a generator to recharge first rechargeable energy source 70 or provide electrical power to other components of system 10. System 10, as shown in FIGS. 22-29, may advantageously operate in a variety of modes.

[0141] FIG. 22 illustrates system 10 in a series mode of operation as the vehicle is accelerating. First prime mover 20 turns fifth prime mover 260 which charges first rechargeable energy source 70. Clutch 165 is disengaged to decouple fifth prime mover 260 from transmission 30. First rechargeable energy source 70 provides electrical power to second prime mover 50 and third prime mover 220 which drive transmission 30 through first component 40 and second component 110, respectively. According to other exemplary embodiments, only one of second prime mover 50 and third prime mover 220 may provide power to transmission 30.

[0142] FIG. 23 illustrates system 10 in a series mode of operation as the vehicle is accelerating according to another exemplary embodiment. First prime mover 20 turns fifth prime mover 260 which charges first rechargeable energy source 70. Clutch 165 is disengaged to decouple fifth prime mover 260 from transmission 30. First rechargeable energy source 70 provides electrical power to second prime mover 50 and third prime mover 220 which drive transmission 30 through first component 40 and second component 110, respectively. According to other exemplary embodiments, only one of second prime mover 50 and third prime mover 220 may provide power to transmission 30. Clutch 245 is engaged so first prime mover 20 further drives fourth prime mover 240. Fourth prime mover 240 may be used to power on-board accessories 250 and/or recharge first rechargeable energy source 70.

[0143] FIG. 24 illustrates system 10 in a parallel mode of operation as the vehicle is accelerating. Power from both first prime mover 20 and first rechargeable energy source 70 is used to power the drive train. First prime mover 20 turns fifth prime mover 260 and transmission 30. Clutch 165 is engaged to couple fifth prime mover 260 to transmission 30. First rechargeable energy source 70 provides electrical power to second prime mover 50 and third prime mover 220 which drive transmission 30 through first component 40 and second component 110, respectively. According to other exemplary embodiments, only one of second prime mover 50 and third prime mover 220 may provide power to transmission 30. First rechargeable energy source 70 further powers fourth prime mover 240. Clutch 255 is engaged so fourth prime mover 240 is coupled to first prime mover 20 to assist driving the drive train. To reduce clutch wear, clutch 165 may be disengaged and second prime mover 50 and third prime mover 220 (via components 40 and 110) may provide the initial power to accelerate the vehicle. This method may also reduce or eliminate the need for a torque converter. Once the input shaft is

close to or the same speed as the engine drive shaft, clutch 165 is engaged to couple first prime mover 20 and transmission 30.

[0144] FIG. 25 illustrates system 10 in a cruising mode with first prime mover 20 providing the power to maintain a relatively constant speed for the vehicle (e.g., during highway driving). Unnecessary loads such as unused hybrid components, are disconnected. Directly coupling first prime mover 20 to drive shaft 32 provides best efficiency when first prime mover 20 can operate at a steady state in an efficient rpm and load range.

[0145] As shown in FIG. 26, hybrid components of system 10 may be temporarily engaged when vehicle is in a cruising mode (FIG. 25) to slow or accelerate the vehicle. First rechargeable energy source 70 may provide additional power to the drive train through one or more prime movers to accelerate the vehicle. After vehicle resumes a steady highway cruise, the additional prime movers can be disengaged (e.g., by disengaging components 40 and 110) to remove unnecessary resistance of unneeded hybrid components. Temporarily using hybrid components to provide additional power to the drive shaft allows a smaller horsepower engine to be used in its optimal range for maximum efficiency. Large swings in required output from the ICE are further reduced. Internal combustion engines generally operate less efficiently when required to provide large transient loads or when power output is much higher or lower than the optimal range. As alternative embodiment, additional prime movers may be engaged if needed to slow or accelerate the vehicle. For example, second prime mover 50 can be coupled to transmission 30 through first component 40 to provide additional acceleration or slow the vehicle.

[0146] To reduce idle time of the internal combustion engine, first prime mover 20 may be turned off when the vehicle is stationary, as shown in FIG. 27. Second prime mover 50 is powered by first rechargeable energy source 70 and drives accessory 60 and equipment 100. According to other exemplary embodiments, accessory 60 may be provided between first component 40 and second prime mover 50 (as shown in FIG. 13).

[0147] As shown in FIG. 28, first prime mover 20 may be used to recharge first rechargeable energy source 70. According to one exemplary embodiment, accessory 60 is a hydraulic pump. If the rotational speed of second prime mover 50 needs to vary (e.g., to accommodate changes in required hydraulic flow), component 110 is engaged and used to recharge first rechargeable energy source 70 through third prime mover 220. Second prime mover 50, meanwhile, can operate independently to provide power to accessory 60 with varying rotation speed. First rechargeable energy source 70 may further provide power to fourth prime mover 240 to drive on-board accessories 250. According to another exemplary embodiment, if the rotational speed of the hydraulic pump is constant, component 40 may be engaged so that first prime mover 20 drives accessory 60 and second prime mover 50 without the intermediate recharging step. According to still another exemplary embodiment, rotational speed of second prime mover 50 may be varied and component 110 may be absent. The system may be charged while varying flow by keeping the rotational speed of accessory 60 constant while varying the output of the pump to change flow (e.g. on a digger derrick application in which the speed of the auger must be changed by adjusting flow).

[0148] As shown in FIG. 29, first prime mover 20 may be used to recharge first rechargeable energy source 70. First prime mover 20 turns fifth prime mover 260 which charges first rechargeable energy source 70. Clutch 165 is disengaged to decouple fifth prime mover 260 from transmission 30. Second prime mover 50, meanwhile, can operate independently to provide power to accessory 60 with varying rotation speed. First rechargeable energy source 70 may further provide power to fourth prime mover 240 to drive on-board accessories 250.

[0149] According to another exemplary embodiment, system 10 may be an idle reduction system. An idle reduction system may have a configuration similar to any previously described embodiment of system 10 but is not configured to provide power back to first prime mover 20 and drive shaft 32 (e.g., the drive train). Instead, component 40 only provides power in one direction (e.g., component 40 does not back-drive into transmission 30). Such a system 10 does not require additional software, calibration and control electronics that is required for the integration of a hybrid drive system. Such a system 10 may also not require sophisticated thermal management systems and higher capacity motors and drive electronics. Such a system 10 may include an optional secondary rechargeable power source 90 such as an accumulator and/or an optional APU 80 or may even include a connection to a power grid. Similar to the embodiment shown in FIG. 14, system 10 may include an optional clutch 160 between component 40 and second prime mover 50 or accessory 60. If system 10 does not include a second rechargeable power source 90 such as an accumulator, system 10 may include air, wireless or fiber optic controls. If system 10 includes a second rechargeable power source 90, no additional control system is required (e.g., the accumulator forms a closed centered hydraulic system with hydraulic controls).

[0150] As an example, in one idle reduction configuration, a PTO with an integrated clutch is connected to a transmission and is coupled to a hydraulic motor. The hydraulic motor has a thru-shaft and is also coupled to an electric motor. The motor may be an AC motor or a DC motor. Batteries supply energy to the motor, electronics control motor speed and turn motor on and off. The PTO may be disengaged from the transmission to allow the electric motor to move the hydraulic pump. It may be necessary to modify the PTO to allow the shaft to spin freely when not engaged with the transmission. When the batteries reach a low state of charge, or the electric motor speed slows below an acceptable level due to low battery energy, the prime mover (usually a diesel or gas engine) is started. The engine rpm is adjusted so that the PTO shaft will provide the needed rotational speed for the hydraulic pump. PTO is then engaged and drives the hydraulic pump.

[0151] The batteries can be charged through the electric motor, or through a vehicle alternator, or alternatively the batteries may remain depleted at the job-site and recharged once the vehicle returns to a location in which power from the grid can be used to recharge the batteries. If batteries remain depleted, the engine is started, PTO is engaged and hydraulic pump or other auxiliary equipment often used on a work truck at a job-site is mechanically powered by the first prime mover (ICE).

[0152] The location to charge the vehicle may be a garage with a charging station or an ordinary plug. Using only grid power to recharge the batteries can simplify the idle reduction system. A separate vehicle monitoring system may record if the batteries are recharged at a garage overnight, or if the

batteries need to be serviced or replaced. Such a system may send a signal via a link (such as cellular, satellite, or wireless local area network, or a wired connection) to a fleet management system so that fleet personnel can take action to maintain system or train vehicle operators.

[0153] The battery system may be designed to be modular and easy for replacement battery modules to be installed. A modular, replaceable battery system can allow a vehicle to use a lower cost battery initially that has a shorter useful life and then replace it when the existing battery no longer can store sufficient energy, with the same type of battery, or a more advanced battery. A replaceable battery system may be beneficial since lower cost batteries can be used until more advanced batteries capable of more energy storage, lower mass and greater service life are available at lower costs. The battery system may have electronics integrated in a module and may include thermal management. The electronics may produce uniform input and output electrical characteristics, allowing for different battery technologies to be used, without affecting idle reduction performance. The battery may also be designed for quick replacement. Such a design could make it possible to use batteries that are charged at a base station. Batteries at a base station may provide power for a facility or to the grid when not needed for a vehicle. There may be additional electronics integrated with the battery module including monitoring circuitry to record power available, power used, how much of the battery life has been reduced (possibly based upon overall percent discharge, rate of discharge and recharge, average operating temperature, frequency of balancing various cells or frequency of achieving full state of charge). Such a system may allow for rental of a battery system or payment based upon battery usage and estimated reduction in battery useful life. This type of modular battery system can also be used on other embodiments of hybrid systems described in this disclosure.

[0154] As has been discussed, system 10 may perform many different functions. The function of the various exemplary embodiments of system 10 may change based on the behavior of the vehicle that includes system 10. For example, when the vehicle is braking, regenerative braking may be used to recharge first rechargeable energy source 70 and/or second rechargeable energy source 90. During acceleration, first rechargeable energy source 70 and/or second rechargeable energy source 90 may be used to provide power to the drive train. When the vehicle is parked, on-board equipment 100 such as a hydraulic lift may be activated. Such a hydraulic lift would draw power from second rechargeable energy source 90 (e.g., a hydraulic accumulator) or be driven directly by an accessory 60 such as a hydraulic pump. Once the lift is raised and stops, hydraulic fluid no longer flows. In this position, second rechargeable energy source 90 does not have to be charged and accessory 60 does not have to run to keep the hydraulic lift raised. Therefore, when the lift is not moving, second prime mover 50 may be turned off to reduce unnecessary consumption of energy from first rechargeable energy source and first prime mover 20 may be turned off to reduce unnecessary idling. Prime mover 20 may remain off when the vehicle is parked if there is sufficient energy in rechargeable energy sources for equipment, or "hotel loads", or power that is exported from the vehicle to power tools or lights or other loads. System 10 may include sensors and a control system to automatically turn on and off first prime mover 20, second prime mover 50, accessory 60, or other

components of system 10 when they are not needed thereby conserving fuel and reducing emissions.

[0155] According to various exemplary embodiments, the elements of system 10 may be coupled together with fluid couplings. One exemplary embodiment of such coupling 170 is shown in FIG. 17 coupling a component 40 to a second prime mover 50. Fluid coupling 170 includes one or more hydraulic motors/pumps 172 and a fluid channel 174 that couples together the hydraulic motors/pumps 172. While fluid couplings 170 may increase the cost of system 10, they allow greater flexibility in the placement of the various elements of system 10 over that which would be generally possible if the elements are coupled with mechanical shafts.

[0156] According to another exemplary embodiment, a Vehicle Monitoring and Control System which oversees the various inputs to the traction system. The VMCS manages the following input/outputs in order to determine the amount and frequency of the power being applied to the PTO in order to maintain vehicle drivability and optimize overall efficiency:

[0157] Accelerator pedal position

[0158] Engine throttle position

[0159] Battery voltage

[0160] Vehicle speed

[0161] Torque request

[0162] During driving, two specific modes are entered: 1) acceleration mode and 2) stopping mode. During acceleration mode, the system routes power from the electric motor through transmission to the wheels. During stopping mode the electric motor provides resistance through the transmission to wheels in order to create electrical energy while stopping the vehicle (also called regenerative energy).

[0163] Others such as Gruenwald and Palumbo '165 used a AC induction motor which produces less torque than the motor (for a given weight and size)

[0164] Another embodiment has selected a permanent magnet motor which provides the additional torque for launch assist and regenerative braking to make the system more effective. Palumbo makes a note that the 215 frame is the largest induction style motor which can fit, which limits the power of the machine utilized.

[0165] Another embodiment also alters the way the transmission shifts now by changing the CAN (vehicle network) commands for down/up shifting in order provide undetectable power blending from the electric motor and the engine through the transmission to the wheels.

[0166] In addition the transmission's torque converter is locked and unlocked. The variable state torque converter on the transmission types being used with the PTO Hybrid technology is to reduce the effective losses in the engine and torque converter during regenerative braking.

[0167] In this way, the vehicle monitoring and control system (VMCS) which incorporates the Driver Interface Node (DIN), Auxiliary Power Unit controller (APUC), Charge Port Interface (CPI), Battery management System (BMS), and the Master Events Controller (MEC) as well as other subsystems oversees control and changeover between operating modes as well as the details of power blending, shift control, torque converter locking and unlocking, damping control, and safety aspects of regenerative braking in the midst of anti-lock or stability control events.

[0168] Therefore, the vehicle power drive system of certain embodiments includes an internal combustion engine connected through a transmission to drive wheels of the vehicle. The transmission has a power take off (PTO) and PTO output

gear. A parallel hybrid drive system, which is connected to the PTO includes an electric motor, an energy storage system (such as, for example, a battery system) and a vehicle monitoring and control system (VMCS). The electric motor is connected through a shaft to the PTO for bi-directional power flow. Typically, the electric motor operates an accessory device such as a hydraulic pump, an air compressor and a mounted accessory. The energy storage system is connected to the electric motor for sending and receiving electric power. The vehicle monitoring and control system (VMCS) has:

[0169] a) a first, accelerating mode for delivering electric power from the energy storage system to the electric motor, to provide drive power to the transmission for supplementing drive power being delivered by the engine to the wheels of the vehicle and,

[0170] b) a second, deceleration mode having the electric motor receive shaft power from the PTO while acting as a generator, to provide regenerative braking and recharging the energy storage system when the engine is not delivering power to the wheels, wherein further the PTO can be disengaged from the transmission, allowing the electric motor to freely provide power to the aforesaid accessory device from the energy storage system.

[0171] The PTO is connected to a PTO output gear in the transmission. The aforesaid energy storage system preferably includes a battery pack, a battery charger for charging the battery pack using an outside electric power source, and a battery management system. The electric motor can have an optional auxiliary power take off, which can be disengaged when the VMCS is in the first mode. The VMCS optionally includes a dampening function to reduce vibration and gear backlash in the PTO when engaging either a switching mode, wherein the dampening function monitors the velocity and speed of the electric motor, thereby creating a closed-loop feedback loop to ensure smooth and efficient operation of the vehicle power drive system. The electrical motor can optionally be a permanent magnet motor providing additional torque during the aforesaid first accelerating mode and more regenerative power in the aforesaid second deceleration mode.

[0172] The VMCS preferably monitors accelerator pedal position, engine throttle position, battery voltage, vehicle speed, and/or torque request to determine the amount and frequency of power being applied to the PTO for maintaining vehicle drivability and optimize overall efficiency.

[0173] The hybrid system preferably includes a high voltage DC connection center between the energy storage system and an inverter for the electric motor to control electric power flow between the energy storage system, such as, for example, a battery system, and the electric motor.

[0174] The VMCS preferably has a third park/neutral mode in which the electric motor recharges the battery pack. Additionally, the VMCS preferably has a fourth, all-electric stationary mode with the engine shut down, in which the electric motor operates the auxiliary power take off.

[0175] In general, the vehicle power drive system of the present includes an internal combustion engine connected through a transmission to drive wheels of a vehicle, with the transmission having a power take off (PTO), wherein the drive system is retrofitted by the steps of:

[0176] a) connection a parallel hybrid drive system to the PTO through a bi-directional power flow shaft, wherein the

parallel hybrid drive system comprising an electric motor, an energy storage system, and an vehicle monitoring and control system (VMCS); and,

[0177] b) the VMCS controls the parallel hybrid drive system to use the electric motor to supplement drive power to the wheels of the vehicle when the internal combustion engine is driving the wheels and provides regenerative braking when the engine is not delivering power to the wheels whereby the battery in the parallel hybrid drive system is recharged.

[0178] The retrofitting can also include the step of connecting the PTO to a torque converter in the transmission, as well as the step of recharging the energy storage system using an outside electric power source. The retrofitting can also include the step of withdrawing auxiliary power from the electric motor when the electric motor is recharging the energy storage system, or the step of disengaging the auxiliary power take off when the electric motor is delivering shaft power to the transmission.

[0179] Preferably, the VMCS uses a dampening function to reduce vibration in the PTO when switching between supplemental drive power and regenerative braking. The VMCS preferably also monitors accelerator pedal position, engine throttle position, battery voltage, vehicle speed, and/or torque request to determine the amount and frequency of power being applied to the PTO for maintaining vehicle drivability and to optimize overall efficiency.

[0180] The hybrid system can use a high voltage DC connection center between the energy storage system and an inverter for the electric motor, to control electric power flow between the energy storage system and the electric motor, which can also recharge the energy storage system during park or neutral position of the transmission.

[0181] The VMCS also provides a method for tuning the amount of power provided for launch assist and regenerative braking power applied in the forward and/or reverse direction, wherein further the VMCS has a tuning charge for the setting provided for each gear, the settings including pedal position vs. positive or negative torque applied, battery voltage vs. torque provided, torque provided vs. state of charge (SOC), and driver inputs including system disable.

[0182] The system also shifts through the gear, and the transmission provides a signal over the vehicle data network to, wherein the VMCS, in order to provide advanced notice of a shift event, and wherein further based upon this information and the pedal position, so that the VMCS can increase or decrease the power provided to the electric motor, allowing for smoother and more efficient shifting, thereby enhancing the vehicle ride and reducing fuel consumption.

[0183] The VMCS also preferably interfaces with any original equipment manufacturers (OEM) vehicle data system in order to eliminate or reduce regenerative braking based on anti-lock or traction control events.

[0184] FIG. 30 is a high level functional illustration of another embodiment of a hybrid vehicle drive system. The illustration shows the interrelation of all the systems the proposed parallel hybrid propulsion system as affixed to a automatic transmission (2) powered by an internal combustion engine (1) in a class 6, 7 or 8 bus or truck.

[0185] Elements (1), (2), (3), (7) and (8) are typical components found in a conventional Class 6, 7 or 8 truck or bus. These include the internal combustion engine (1), the transmission (2), a power take-off (PTO) element (3), wherein the transmission (2) communicates with a differential (7) driving wheels (8). Those skilled in the art understand the operation

of these components and how they interact with each other under typical driving conditions.

[0186] The mechanical portion of the embodiment is illustrated in the elements including PTO device (3), electric power (4), power electronics/battery (5), Vehicle Monitoring and Control System (VMCS) (6) and an auxiliary device (10A), such as a compressor. The PTO element (3) is connected to an electric motor (4) with a short driveshaft (9). The shaft (9) can transmit power into or out of the PTO element (3). The electric motor (4) is powered by a power electronics/battery system (5), also a bi-directional system which can provide power to, or accept power from the electric motor (3) which is acted on mechanically via the PTO (3).

[0187] The Vehicle Monitoring and Control System (VMCS) (6) oversees the operation of the power electronics/battery system (5) by monitoring the inputs described above along with providing output data to the driver and/or other on-board vehicle systems.

[0188] An optional auxiliary device, (10) such as a compressor (10), can be mounted on the electric motor end shaft. These auxiliary systems can include a variety of rotating machines used to transmit fluids and/or power via the PTO.

[0189] Operational Modes:

[0190] The following diagrams shown in FIGS. 31-37 are illustrations of the power flow in each of the operational modes that the PTO Hybrid can be operated within:

[0191] FIG. 31 is an Overall system diagram.

[0192] FIG. 32 is a Driving mode during acceleration.

[0193] FIG. 33 is a Driving mode during deceleration.

[0194] FIG. 34 is a Driving mode during park/neutral.

[0195] FIG. 35 is a Stationary mode during an all electric operation.

[0196] FIG. 36 is a Stationary mode during engine operation.

[0197] FIG. 37 is a Plug in mode during battery charging.

[0198] FIGS. 33-37 illustrate the flow of mechanical energy, electrical energy, controls power and control logic within each of the operational modes.

[0199] FIG. 31 shows major subsystems and elements used in a PTO hybrid system of this embodiment. Most of the blocks shows are self-explanatory, however some may need elaboration. Note the "battery isolator/combiner" (15) on the left center; this controls connections between the vehicle battery (16) and a separate 12V battery (17) which operates control systems as well as "Heating System" (18). The central block "High Voltage DC Connection Center" (19) has 3 connections; to the inverters (20A) which convert DC from the battery packs to AC to operate the PM motor, and to the DC to DC converter (21) which steps the 600VDC down to 12V for typical vehicle loads including connections to both 300V battery packs, SES1 (25) and SES2 (26) with their own local management systems and chargers. The AC charge port (30) on the right connects through charge port interface (31) (CPI) to both battery chargers. Note that the "Electric Motor" (4) which is used through the "PTO clutch" (3) for both acceleration and regenerative braking also powers a "Hydraulic Pump" (35) for buckets hydraulics. Auxiliary power unit controller (37) ("APUC") and driver interface node (38) (DIN) provide the power requirement to the Motor/Drive Inverter motor based on the accelerator pedal position and the power required during stationary mode operation respectively, with the "Motor Drive/Inverter" (20A) which in turn provides electric energy to the electric motor.

[0200] In FIG. 32, during the acceleration mode, power flows from both 300V battery packs, through the high voltage DC connection center (19), and the motor drive/inverter (20A) to the electric power (4) which drives the wheels (8) through its PTO entry point blending its power with that from engine 91. This launch assist is controlled by demand as well as the charge status of battery packs SES1 (25) and SES2 (26); it recycles energy gathered during braking to reduce fuel consumption and pollution.

[0201] In contrast, in FIG. 33 during the deceleration mode, mechanical power flows from the differential (7) and gear box through the PTO (3), spinning the electric motor (4) as a generator to charge up both 300V battery packs through the motor drive/inverter (20) and the high voltage connection center (19). Thus energy which would have been wasted as heat in the brakes is recovered for later use.

[0202] FIG. 34 shows a typical operation while the vehicle is in "Park/Neutral" with the engine (1) running whereby engine power can be used to spin the electric motor (4) through the PTO (3) as a generator to top up both 300V battery packs and/or power the auxiliary drive. Note that in this mode the hydraulic pump (35) is disengaged from the electric motor (4).

[0203] FIG. 35 shows activity which can be supported by the PTO hybrid system of this invention while the vehicle is parked with the engine (3) off. In this mode, no site pollution or emissions are generated, and engine noise is absent. All power is provided from the two 300V battery packs. This all-electric mode can power bucket hydraulics, auxiliaries, and charging of vehicle 12V battery 916) as well as a 12V battery through a DC/DC converter 921). The bold power arrows show the flow paths.

[0204] FIG. 36 shows the power flow for the engine-driven counterpart stationary mode. In this mode all power is derived from the engine (1), and the 300V battery packs can be recharged via engine power. This mode can be used briefly until the 300V batteries are charged if they had been depleted at a work site in all-electric mode. However, this mode can also supply bucket hydraulics since the motor 94), while spun by the engine (1) as a generator to charge the 300V battery packs, is also shaft-connected to the hydraulic pump (35).

[0205] FIG. 37 is a diagram showing the connections for plug-in charging at a charging station. 12V battery chargers not part of the vehicle system are used to charge the two 12V batteries, while the chargers built into 300V packs SES1 (25) and SES2 (26) are used to charge those high voltage packs.

[0206] It is also important to note that the arrangement of the hybrid drive system components, as shown, are illustrative only. Although only a few embodiments of the present disclosure have been described in detail, those skilled in the art who review this disclosure will readily appreciate that many modifications are possible (e.g., variations in sizes, dimensions, structures, shapes and proportions of the various elements, values of parameters, mounting arrangements, materials, colors, orientations, etc.) without materially departing from the novel teachings and advantages of the subject matter recited herein. Further, the discussions related to optional clutches apply to other embodiments described with respect to other Figures. For example, although an APU 80 and optional clutches are shown in various embodiments, they can be removed from the system without departing from the scope of the invention unless specifically recited in the claims. Accordingly, all such modifications are intended to be included within the scope of the present disclosure as

described herein. The order or sequence of any process or method steps may be varied or re-sequenced according to alternative embodiments. Other substitutions, modifications, changes, and/or omissions may be made in the design, operating conditions and arrangement of the preferred and other exemplary embodiments without departing from the exemplary embodiments of the present disclosure as expressed herein.

What is claimed is:

1. A power supply for powering a hydraulic implement, the power supply comprising:

an electric storage unit, an electric motor, an electric generator, a hydraulic pump and a control unit, the electric motor, the electric generator and the hydraulic pump abut against one another in direct contact; the electric motor adapted for receiving electric power and driving the hydraulic pump to power the hydraulic implement; the electric generator adapted for translating mechanical energy from a power take off into the electric power; the electric storage unit also being adapted for providing the electric power; and

the control unit configured for automatically switching between electric power from the generator driven by an engine coupled to the power take off and electric power from the electric storage unit coupled to the electric motor, the electric motor driving the hydraulic pump unassisted by the engine.

2. The power supply as in claim 1, wherein the control unit is adapted for directing at least a portion of the electric power from the generator to the electric storage unit.

3. The power supply as in claim 1, wherein the control unit is adapted for automatically starting the engine to provide the mechanical energy based on the charge in the electric storage unit.

4. The power supply as in claim 3, wherein the control unit is adapted for automatically shutting down the engine based on the charge in the electric storage unit.

5. The power supply as in claim 1, further comprising an electrical connection for coupling to at least one of another separate electrical generator and an external power supply.

6. The power supply as in claim 1, wherein the electric storage unit comprises at least one of a battery and a fuel cell.

7. The power supply as in claim 1 wherein the electric generator is adapted for coupling with a power take off.

8. The power supply as in claim 1, wherein a single unit comprises the electric motor and the electric generator.

9. The power supply as in claim 1, wherein the control unit comprises at least one of a processor, a memory, a storage, an interface, a wireless interface, a remote interface, a user input device, a display, an auditory input and an audible output.

10. A method for powering a hydraulic implement, the method comprising:

driving a hydraulic pump with an electric motor, the electric motor powered by electric power from an electric storage unit, the electric motor and the hydraulic pump abut against each other in direct contact, the hydraulic pump configured for driving the electric motor;

upon depletion of the electric storage unit, starting an engine to drive a power take off unit;

driving a generator with the power take off unit; and

charging the electric storage unit and powering the hydraulic pump from the power take off unit coupled to the engine.

11. The method as in claim 10, further comprising shutting down the generator when the electric storage unit is adequately charged.

12. The method as in claim 10, further comprising continuously monitoring the depletion.

13. The method as in claim 10, further comprising at least one of tracking performance, obtaining diagnostic information and governing a setpoint for indication of at least one of depletion and adequate charge.

14. The method as in claim 10, wherein starting the generator further comprises starting at least one of the engine and a separate electrical generator.

15. A vehicle comprising at least one hydraulic system for powering a hydraulic implement, the vehicle comprising:

a hybrid power supply for powering the hydraulic system, the hybrid power supply comprising an electric storage unit;

an electric motor, an electric generator, a hydraulic pump and a control unit, the electric motor, the electric generator and the hydraulic pump abut against one another in direct contact;

the electric motor adapted for receiving electric power and driving the hydraulic pump to power the hydraulic implement;

the electric generator adapted for translating mechanical energy from a power take off of the vehicle into the electric power; the electric storage unit also being adapted for providing the electric power; and

the control unit for automatically switching between electric power from the generator driven by an engine coupled to the power take off and electric power from the electric storage unit coupled to the electric motor, the electric motor driving the hydraulic pump unassisted by the engine.

16. The vehicle as in claim 15, wherein the hybrid power supply is adapted for at least one of assisting an engine of the vehicle and braking the vehicle.

17. A power supply for powering a hydraulic implement, the power supply comprising:

a hydraulic pump hydraulically connected to the hydraulic implement;

an electric motor/generator and the hydraulic pump abut against one another in direct contact, the electric motor/generator configured to drive the hydraulic pump;

an electric storage unit coupled to the electric motor/generator for delivery of electric power thereto for driving the hydraulic pump;

a power take-off mechanically coupled to the electric motor/generator for delivery of mechanical power thereto and generation of electric power thereby for driving the hydraulic pump; and

a control unit configured to automatically switch the operation of the electric motor/generator between electric power from the electric storage unit and mechanical power from the power-take off, wherein the electric motor/generator is configured to drive the hydraulic pump unassisted by the power take-off, the control unit is adapted for automatically shutting down the engine based on the charge in the electric storage unit.

* * * * *