



(51) International Patent Classification:

*A61K 8/02* (2006.01)      *A61Q 19/00* (2006.01)  
*A61K 8/11* (2006.01)

(21) International Application Number:

PCT/CN2012/070476

(22) International Filing Date:

17 January 2012 (17.01.2012)

(25) Filing Language:

English

(26) Publication Language:

English

(71) Applicant (for all designated States except US):  
L'OREAL [FR/FR]; 14 rue Royale, F-75008 Paris (FR).

(72) Inventors; and

(75) Inventors/Applicants (for US only): **LIU, Xuedong** [CN/CN]; 1028 Yunqiao Road, Pudong, Shanghai 201206 (CN). **ZHU, Rong** [CN/CN]; Room 1105, No. 19, 1083 Ping Xing Guan Road, Shanghai (CN). **CHU, Juan** [CN/CN]; Room 1002, No. 132, 607 Ziwei Road, Shanghai (CN). **YU, Qing** [CN/CN]; Room 1102, Lane 210-2, North Linyi Road, Shanghai (CN). **CHEN, Jing** [CN/CN]; 1028 Yunqiao Road, Shanghai (CN).

(74) Agent: **TDIP & PARTNERS**; Room 2002 A-Building North Ring Center, No.18 Yumin Road Xicheng District, Beijing 100029 (CN).

(81) Designated States (unless otherwise indicated, for every

kind of national protection available): AE, AG, AL, AM, AO, AT, AU, AZ, BA, BB, BG, BH, BR, BW, BY, BZ, CA, CH, CL, CN, CO, CR, CU, CZ, DE, DK, DM, DO, DZ, EC, EE, EG, ES, FI, GB, GD, GE, GH, GM, GT, HN, HR, HU, ID, IL, IN, IS, JP, KE, KG, KM, KN, KP, KR, KZ, LA, LC, LK, LR, LS, LT, LU, LY, MA, MD, ME, MG, MK, MN, MW, MX, MY, MZ, NA, NG, NI, NO, NZ, OM, PE, PG, PH, PL, PT, QA, RO, RS, RU, RW, SC, SD, SE, SG, SK, SL, SM, ST, SV, SY, TH, TJ, TM, TN, TR, TT, TZ, UA, UG, US, UZ, VC, VN, ZA, ZM, ZW.

(84) Designated States (unless otherwise indicated, for every

kind of regional protection available): ARIPO (BW, GH, GM, KE, LR, LS, MW, MZ, NA, RW, SD, SL, SZ, TZ, UG, ZM, ZW), Eurasian (AM, AZ, BY, KG, KZ, MD, RU, TJ, TM), European (AL, AT, BE, BG, CH, CY, CZ, DE, DK, EE, ES, FI, FR, GB, GR, HR, HU, IE, IS, IT, LT, LU, LV, MC, MK, MT, NL, NO, PL, PT, RO, RS, SE, SI, SK, SM, TR), OAPI (BF, BJ, CF, CG, CI, CM, GA, GN, GQ, GW, ML, MR, NE, SN, TD, TG).

Published:

— with international search report (Art. 21(3))

(54) Title: COLOUR CHANGING COMPOSITION IN GEL FORM

(57) Abstract: A changing colour composition on the form of a gel for caring for and/or making up keratin materials is disclosed. The composition comprises in a physiologically acceptable medium, a) from 0.1 to 10% by weight preferably from 1 to 5% by weight relative to the weight of the composition of microcapsules containing releasable colorant(s), said microcapsules comprising: - a core comprising one organic material, - at least one layered coating surrounding said core, the layered coating comprising at least one polymer at least one colorant, and advantageously at least one lipid-based material, b) at least 3% by weight, preferably at least 5 by weight, more preferably at least 8% by weight and advantageously at least 10% by weight relative to the weight of the composition of at least one swelling agent, and c) at least one hydrophilic gelifying agent.



WO 2013/106996 A1

## **Colour changing composition in gel form**

### **TECHNICAL FIELD**

The present invention relates to a color-changing composition in the form of a transparent gel in particular useful for care, hygiene and/or makeup of keratin materials.

In particular, a color-changing composition according to the invention may be any type of cosmetic composition such as a foundation, a face powder, an eye shadow, a concealer product, a blusher, a lipstick, a lip balm, a lip gloss, a lip pencil, an eye pencil, an eyeliner, a mascara, a body makeup product, a skin colouring product, a care product such as a care cream, a 'BB' product (Blemish Balm product able to cover imperfections), a tinted cream or an antisen product, preferably a foundation or BB product.

A composition of the invention is especially a composition intended to be applied to a keratin material, in particular the skin and more particularly facial skin, such as a skin care or make-up product for face.

According to another embodiment, the composition of the invention is a mascara.

According to another embodiment, the composition of the invention is a product for lips, in particular a lipgloss, a lipbalm or a lipstick.

### **BACKGROUND**

Cosmetic compositions, especially foundations, are commonly used to give the skin an aesthetic colour, but also to hide skin imperfections such as redness and/or marks. In this regard, many formulations have been developed to date.

In this respect, there is a growing interest in cosmetic products that provide a change in color in response to external incentives such for example shear force.

Generally, this purpose is achieved by including in cosmetic composition microencapsulated colorants wherein, upon application on the skin, the composition provides the expected changing color. More particularly, the change of color is provided by the colorant-containing microcapsules, which upon rupture by application of a mechanical force, release the entrapped colorant into the composition, thereby changing its color. A mechanical action such as rubbing spread the topical composition

and facilitates its penetration into the skin. The immediate change of color of the composition provides a visual esthetical effect.

Different types of entrapped colorants and more particularly pigments-containing microcapsules are already available. They mainly differ through the type of entrapping material(s) and/or the type of encapsulation.

Thus, as pigments encapsulated by microcapsules in acrylic acid and/or methacrylic acid polymers or copolymers, it may be cited for example microcapsules containing copolymer of ethyl acrylate/methacrylic acid ammonium salts, commercialized by the Tagra company and described in WO-A-01/35933. It may be also cited the encapsulated pigments commercialized by TAGRA BIOTECHNOLOGIES under the name BLACKCAP1<sup>®</sup>, YELLOWCAP1<sup>®</sup>, REDCAP1<sup>®</sup>, BLACKCAP3<sup>®</sup>, YELLOWCAP3<sup>®</sup>, REDCAP3<sup>®</sup>.

As pigments encapsulated by microspheres in cellulose derivatives, it can be cited for example spheres comprising cellulose, hydroxypropyl methylcellulose, commercialized by the Induchem company under the name Unisphere<sup>®</sup>.

As pigments encapsulated by microcapsules in polymers of polyester, polyaminomethacrylate, polyvinylpyrrolidone, hydroxypropylmethylcellulose, shellac types and mixtures thereof, it may be notably cited those described in the application US 2011/0165208 of Biogenics and commercialized under the name Magicolor<sup>®</sup> by Biogenics.

As other pigments encapsulated by microcapsules may also be cited the ones disclosed by DAITO in JP2011-79804, these pigment-encapsulated double-layer microcapsules comprising three or more of the following (a) mannitol, (b) hydrogenated lecithin, (c) polymethylmethacrylate, (d) cellulose and (e) shellac.

These double-layer microcapsules do not comprise an uncoloured core as the one of the microcapsules preferably used according to the invention, but rather a colored inner layer containing the aforesaid components which are mixed all together and then granulated.

However, with some colorant-containing microcapsules it may be difficult to permanently retain the colorant over long periods of time and when subjected to different environments and conditions. This is true of pigments, oil soluble dyes, and water soluble dyes. Thus, some microcapsules described in patents and publications have been found to gradually release the colorant, or to "bleed", over time when tested for prolonged periods at elevated temperatures. Color bleed occurs when a dye or pigment migrates through or off of microspheres/microcapsules through contact with

moisture and/or other ingredients in a formulation such as alcohols or glycols, surfactants, silicones, oils, preservatives, salts and other components typically found in cosmetic formulations. Leeching or bleed of the colorant in cosmetic composition can impair the long term visual effect of the cosmetic both in the container and on the substrate.

Furthermore, some pigment-containing microcapsules may confer a lower covering effect than expected.

Furthermore, some pigment-containing microcapsules are immediately broken down at the time of application so, while there is the fun of a sudden colour change, it has not been possible to realise intermediate stages in this colour change or to adjust the colour gradation.

Furthermore, some pigment-containing microcapsules may have some stability issues depending on the cosmetic composition and associated solvents/ingredients.

Furthermore, some pigment-containing microcapsules may have a grey color aspect that confers a not attractive color in the bulk of the cosmetic composition.

At last, some microcapsules may provide a discomfort and/or unfavourable feeling when the cosmetic formulation including them is applied on a keratin material.

As far as transparent gels are concerned, the technical problem was to propose a composition with cleaning, caring and transparent appearance which provides good makeup effects, particularly a good covering effect. Transparent gel usually attracts lots of consumers by its watery, breathable, cute, beautiful and transparent bulk appearance, which delivers a message of fresh, watery, hydrating and caring perception to consumer. However, there is a need of a product, which can be pure and clean as transparent gel, but can still deliver some makeup results.

Technical barriers for design this kind of products, are first the difficulty to wrap pigment in transparent gel and still keep its transparency, secondly the bad compatibility of microcapsules for watery transparent gel, thirdly the hardness of the microcapsules: they are not easy to be broken and as consequence the sensory of gel after application will be dry.

## **SUMMARY**

Thus there is a need to provide cosmetic gel with colorant-containing microcapsules having improved color bleed resistance. In this respect, there is a need of colorant-containing microcapsules, which capsules retain good shatter resistance and exhibit improved bleed resistance. In a cosmetic composition if the dye is not permanently retained, this can impair the long-term visual effect of the cosmetic.

There is also a need to provide a cosmetic gel which allows the preferred colouration or gradation pattern to be adjusted by varying the method or intensity of application onto the skin or the use of microcapsules containing different colorants.

There is also a need to provide a cosmetic gel stable with a large panel of solvent/ingredient associated.

There is also a need to provide a cosmetic gel wherein the microcapsules are or are not visible inside the bulk of the composition depending on the desired appearance.

There is also a need for a cosmetic gel containing pigment-encapsulated microcapsules which do not provoke to the user a discomfort feeling when applied.

Thus, according to one of its aspects, a subject of the invention is a changing colour composition on the form of a gel for caring for and/or making up keratin materials comprising, in a physiologically acceptable medium,

a) from 0,1 to 10% by weight preferably from 0,5 to 10% more preferably from 1 to 5% by weight relative to the weight of the composition of microcapsules containing releasable colorant(s), said microcapsules comprising:

- a core comprising one organic material,
- at least one layered coating surrounding said core, the layered coating

comprising

at least one polymer,

at least one colorant,

and advantageously at least one lipid-based material,

b) at least 3% by weight, preferably at least 5% by weight, more preferably at least 8% by weight and advantageously at least 10 % by weight relative to the weight of the composition of at least one swelling agent,

c) at least one hydrophilic gelifying agent.

Advantageously, the microcapsules comprise at least two layers, preferably at least one organic inner layer and one organic outer layer of different colour.

Preferably the core comprises at least one monosaccharide or its derivatives as said organic material, in particular a monosaccharide-polyol advantageously selected from mannitol, erythritol, xylitol, sorbitol and mixtures thereof, preferably mannitol.

Preferably the layered coating surrounding said core comprises at least one hydrophilic polymer(s) selected from the group consisting of polysaccharides and derivatives, preferably the ones including one type of ose or several type of ose(s), preferably several type of ose(s) including at least D-glucose units, in particular starch and derivatives, cellulose or derivatives, and more preferably starch and derivatives.

Particularly, the changing colour gel composition according to the invention comprises microcapsules comprising at least:

- a inner core made of monosaccharide-polyol, preferably mannitol,
- at least two layers of different colour,
- at least one hydrophilic polymer preferably selected from polysaccharide or derivatives, and more preferably from starch or derivatives,
- and advantageously at least one lipid based material, preferably an amphiphilic compound, more preferably a phospholipid, even more preferably phosphoacylglycerol such as hydrogenated lecithin.

Preferably the microcapsules containing releasable colorant(s) are multi-layered microcapsules containing releasable colorant(s), said microcapsules comprising:

- an uncoloured core consisting in one organic material, and
- a multi-layered coating surrounding said core and comprising at least one organic inner layer and one organic outer layer of different colour and entrapping respectively at least one colorant.

Preferably the gel is transparent or translucent.

Particularly the changing colour gel composition according to the invention comprises at least one hydrophilic gelifying agent chosen from water-soluble or water dispersible polymers, preferably chosen from:

- modified or unmodified carboxyvinyl polymers ;
- polyacrylates ;
- polymethacrylates ;
- polyacrylamides; optionally crosslinked and/or neutralized 2-acrylamido-2-methylpropanesulfonic acid polymers and copolymers ;
- crosslinked anionic copolymers of acrylamide and of AMPS ;
- polysaccharide biopolymers, for instance xanthan gum, guar gum, carob

- gum, acacia gum, scleroglucans, chitin and chitosan derivatives, carrageenans, gellans, alginates,
- celluloses such as microcrystalline cellulose, carboxymethylcellulose, hydroxymethylcellulose and hydroxypropylcellulose;
- and mixtures thereof.

More preferably, the water-soluble or water dispersible polymers is chosen from Acrylates/C10-30 Alkyl Acrylate Crosspolymer ; Ammonium acryloyldimethyl Taurate/Steareth-8 Methacrylate copolymer ; Acrylates copolymer ; Ammonium acryloyldimethyl taurate/steareth-25 Methacrylate Crosspolymer ; Ammonium acryloyldimethyl taurate such, and xanthan gum.

Advantageously, in the gel composition, the hydrophilic gelifying agent(s) are in an amount ranging from 0.001 to 10 % by weight, preferably 0.01 to 5% by weight and more preferably from 0.05 to 3% by weight relative to the total weight of the composition.

Particularly, the changing composition further comprises one or more water soluble emollient(s) and/or lipid(s) with a polar moiety.

Particularly, the changing colour gel composition further comprises one or more solubilizers of water soluble emollient(s), preferably chosen from Polysorbate 20, PEG-60 hydrogenated castor oil.

The invention is also directed to a cosmetic process for caring for and/or making up keratinic materials, comprising application on said keratinic materials in particular on the skin of a gel composition as defined according to the invention.

The composition according to the invention, which is preferably a makeup foundation, provides a very strong moisturizing sensation, advantageously a totally transparent and cleaning bulk appearance with very comfortable feeling during application, and sheer natural makeup result after application. At the end, all these characters help deliver a very good balance of skincare efficacy perception (watery, moisturization and transparent) as well as makeup efficacy (proper covering effect).

In particular, the technical problem underlying the present invention has been solved by using a specific microcapsule wherein pigment can be very well encapsulated with colorful and clean appearance.

Particularly transparent or slightly colored gels with colored microcapsules homogeneously dispersed are advantageously obtained.

## **MORE DETAILED DESCRIPTION**

The term “physiologically acceptable medium” is intended to denote a medium that is particularly suitable for applying a product of the invention to keratin materials, especially the skin and more particularly facial skin.

The word “capsule” is also used to mention “microcapsule”.

For the purposes of the present invention, the term “keratin material” is intended to cover the skin, mucous membranes such as the lips, the nails and the eyelashes. The skin and the lips, in particular facial skin, are most particularly considered according to the invention.

As emerges from the examples that follow, compositions in accordance with the invention prove to be advantageous in several aspects.

Encapsulation of the colorants prevents undesirable re-agglomeration of pigments during manufacture and prolonged storage of the cosmetic compositions.

As the microcapsules of the invention have the ability of swelling in contact of a swelling agent as defined hereunder (ex: water, polyols, glycols, alcohols...) they are advantageously deformable when applied on a keratin material and consequently provide a soft feeling to the user. Furthermore, their low size contributes to not create any discomfort or unfavourable feeling when applied.

However, the microcapsules of the invention are soft enough to rupture upon very slight rubbing or pressing on the skin in order to release their content but, nevertheless, are durable enough to avoid destruction of the coating during manufacture and storage of corresponding change-color composition.

In addition, the microcapsule of the invention allows the use of regular equipment for the preparation of the compositions of the invention because no coloring of the apparatus occurs during the manufacturing process.

Accordingly, the microcapsules of the present invention are particularly interesting since they mask the original color of the encapsulated colorants, increase the stability of these colorants against degradation, and prevent undesirable release of the encapsulated colorants into the composition during the manufacturing process and prolonged storage.

At last, compositions of the invention also have the advantage of satisfying a consumer expectation in terms of cosmetic products.

According to another of its aspects, a subject of the present invention is also directed to a cosmetic process comprising at least the steps consisting in applying

at least part of a gel composition according to the invention on the surface of a keratin material, in particular the skin.

According to the invention, the "color changing composition" means a composition wherein the color before application is different from the color after application, this difference being visible to the naked eyes.

In particular, this color changing composition may be linked to a color-difference  $\Delta E$  in CIE Lab system 1976 ( $\Delta E$  before/after application) value.

The  $\Delta E$  is defined by the equation:

$$\Delta E^* = \sqrt{((L_1 - L_2)^2 + (a_1 - a_2)^2 + (b_1 - b_2)^2)}$$

wherein  $L_1, a_1, b_1$  are the parameters in the colorimetric space of the 1st color (composition before application) and  $L_2, a_2, b_2$  the ones for the 2<sup>nd</sup> color (composition after the application and homogenization on the keratinic material).

These values may be measured by spectrophotometer or with a Chromasphere (for composition applied on skin).

The color changing composition according to the invention may be characterized as having a  $\Delta E$  before/after application superior to 1, in particular superior or equal to 2, preferably superior or equal to 3.

### **COLORING MICROCAPSULES**

The term "microcapsule", as used herein, refers to a spherical microcapsule containing at least one layered coating entrapping at least one colorant and surrounding a core chemically different from the coating. Microcapsules are distinct from microspheres, which consist of spherical homogeneous matrix.

According to an embodiment, the "at least one layered coating" is a multi-layered coating preferably an organic multi-layered coating.

The term "multi-layer microcapsule" refers to a microcapsule consisting of an inner core surrounded by a coating based on one or more inner layer(s) and one outer layer. The one or more inner layer(s) forming the multi-layer coating of the multi-layer microcapsule and the single layer of the outer core microcapsule may be formed of the same or different wall-forming organic compound(s).

The microcapsule according to the invention comprises an inner core surrounded by a coating based on one or more inner layer(s) and one outer layer. In a preferred embodiment, the microcapsule is a 'multi-layers' microcapsule, comprising at least one inner layer and one outer layer. The one or more inner layer(s) forming the

multi-layer coating of the multi-layer microcapsule and the single layer of the outer core microcapsule may be formed of the same or different wall-forming organic compound(s).

In one embodiment, the outer layer does not comprise any colorant. In another embodiment, the outer layer comprises at least one colorant.

The term "wall-forming organic compound" refers to an organic compound or a combination of two or more different organic compound as defined herein, which form a component of the outer and inner walls or layers or shells of the microcapsules. In a preferred embodiment, the 'wall-forming organic compound' comprises at least one polymer.

The term "colorant" refers to organic pigments such as synthetic or natural dyes selected from any of the well known FD&C or D&C dyes, inorganic pigments such as metal oxides, or lakes and any combination (blend) thereof. Accordingly, the colorant useful according to the present invention may be oil-soluble or oil-dispersible or with limited solubility in water.

In preferred embodiments, the colorant is an inorganic pigment, more preferably a metal oxide.

Generally average particle size diameters of colorant microcapsules up to about 800 microns are used according to the invention. Preferably the average particle size diameter of the colorant microcapsules is less than about 400 microns for skin care applications. Advantageously the average particle size diameter is in the range of about 10 to 350 microns. Preferably, the average particle size will be from 80  $\mu\text{m}$  to 800  $\mu\text{m}$ , and in particular from 100  $\mu\text{m}$  to 400 $\mu\text{m}$ .

In particular, the average particle size may be from 50 to 1000 Mesh (around 400 $\mu\text{m}$  to 10 $\mu\text{m}$ ), in particular from 60 to 200 Mesh (around 250 $\mu\text{m}$  to 75 $\mu\text{m}$ ).

Preferably, a composition according to the invention may comprise from 0.1% to 10% by weight and preferably from 0.5% to 10% by weight of microcapsules relative to the total weight of the said composition.

In particular for a skin care composition according to the invention, the amount of microcapsules will range from 0.1% to 5%, preferably from 0.2% to 3% by weight relative to the total weight of composition.

In particular for a make-up composition according to the invention, the amount of microcapsules will range from 0.5% to 10%, preferably from 1% to 10%, more preferably from 2% to 10% by weight relative to the total weight of composition.

According to a particular embodiment, the encapsulated colorant(s) may be present in a composition according to the invention in an amount in active matter of

encapsulated pigments ranging from 0.5% to 20% by weight, in particular from 1% to 15% by weight, and more particularly from 2% to 12% by weight, of the total weight of said composition.

They will be integrated in the cosmetic formula generally at the latest stages of the formulation and after filtering stages if any, to avoid broken. Preferably, the microcapsules according to the inventions are added and mixed uniformly at temperatures under 50°C. They are mixed gently with a paddle rather than an homogeneizer.

The microcapsules may be produced by several methods known from the man skilled in the art within the coating or encapsulation domain, including pelletization, granulation, coating, etc.. As example, the microcapsules may be obtained by steps comprising mixture of the compounds (actives, pigments, polymers, solvents) and drying to form capsules as disclosed in WO01/35933 and WO2011/027960, or steps of granulation and coating by spray drying as disclosed in FR2841155, or by fluidized bed technology, which has been used in the food and pharmaceutical industry for a long time for coating and encapsulating ingredients. As example, may be cited WO08139053 for the preparation of spheroid multilayer comprising a core of sugar and concentric layers of pharmaceutical actives. Fixation of pharmaceutical actives on the core is made by impregnation or pulverization or projection, and then the 1<sup>st</sup> layer is dried before application of a second one.

Fluid bed process process is disclosed by example in 'Fluid-Bed Coating, Teunou, E.; Poncelet, 2005, D. *Food Science and Technology (Boca Raton, FL, United States)*, Volume 146 Issue Encapsulated and Powdered Foods, Pages 197-212. The specificity of the fluid bed process is that it leads to real capsules compared to spray drying, which leads to a matrix with the core material randomly dispersed in a polymer.

### **I a) Inner Core**

The inner core, or core, is made of an organic material.

Preferably the core is in a solid or crystal form at room temperature.

In a particular embodiment, the organic material is selected from organic materials having high water dissolvability. Preferably, the core is water-soluble or water-dispersible.

In a particular embodiment, the core is uncoloured, i.e. it does not contain colorant material.

In a particular embodiment, the core is based on only one compound. This compound is organic and more preferably is a natural compound.

According to a preferred embodiment, the core is sugar-alcohol, preferably a monosaccharide-polyol advantageously selected from mannitol, erythritol, xylitol, sorbitol.

In a particular embodiment, the core is made of mannitol.

The core may be constituted by a seed (or crystal) of one of the previous materials.

The core is preferably contained in an amount of from 1% to 50% by weight, preferably 5 to 30% by weight, and in particular from 10 to 20% by weight with respect to the total weight of the micro capsule.

#### **I b) External Layer(s) or coating**

As disclosed previously, a core is advantageously surrounded with a coating, or external layer(s) preferably comprising at least one inner layer and one outer layer. In this latter case, these layers preferably extend concentrically in respect with the core. The outer layer may be the outermost layer or an intermediate layer relatively to the inner layer and an outermost layer.

Both layers are preferably organic, i.e. contain at least one organic compound as wall-forming material. Preferably, the inner and/or outer layers include at least one polymer, and in particular a hydrophilic polymer.

#### **Polymer(s)**

The composition according to the invention comprises one or more polymers. In a particular embodiment, the polymers are hydrophilic polymers.

Such hydrophilic polymer(s) are soluble or dispersible in water or in alcohols compounds, in particular chosen from lower alcohols, glycols, polyols.

For the purposes of the present patent application, the term "hydrophilic polymer" means a (co)polymer that is capable of forming hydrogen bond(s) with water or alcohols compounds, in particular chosen from lower alcohols, glycols, polyols. In particular are concerned O-H, N-H and S-H bonds.

According to a particular embodiment of the invention, the hydrophilic polymer may swell in contact with water or alcohol compounds, in particular chosen from lower alcohols, glycols, polyols.

The hydrophilic polymer(s) may be chosen from the following polymer(s):

- acrylic or methacrylic acid homopolymers or copolymers or salts and esters thereof and in particular the products sold under the names Versicol F or Versicol K by the company Allied Colloid, Ultrahold 8 by the company Ciba-Geigy, and polyacrylic acids of Synthalen K type, and salts, especially sodium salts, of polyacrylic acids (corresponding to the INCI name sodium acrylate copolymer) and more particularly a crosslinked sodium polyacrylate (corresponding to the INCI name sodium acrylate copolymer (and) caprylic/capric triglycerides) sold under the name Luvigel EM by the company;

- copolymers of acrylic acid and of acrylamide sold in the form of the sodium salt thereof under the names Reten by the company Hercules, the sodium polymethacrylate sold under the name Darvan No. 7 by the company Vanderbilt, and the sodium salts of polyhydroxycarboxylic acids sold under the name Hydagen F by the company Henkel;

- polyacrylic acid/alkyl acrylate copolymers, preferably modified or unmodified carboxyvinyl polymers; the copolymers most particularly preferred according to the present invention are acrylate/C<sub>10</sub>-C<sub>30</sub>-alkylacrylate copolymers (INCI name: Acrylates/C<sub>10-30</sub> Alkyl acrylate Crosspolymer) such as the products sold by the company Lubrizol under the trade names Pemulen TR1, Pemulen TR2, Carbopol 1382 and Carbopol ETD 2020, and even more preferentially Pemulen TR-2;

- AMPS (polyacrylamidomethylpropanesulfonic acid partially neutralized with aqueous ammonia and highly crosslinked) sold by the company Clariant;

- AMPS/acrylamide copolymers such as the products Sepigel or Simulgel sold by the company SEPPIC, especially a copolymer of INCI name Polyacrylamide (and) C13-14 Isoparaffin (and) Laureth-7;

- polyoxyethylenated AMPS/alkyl methacrylate copolymers (crosslinked or non-crosslinked) of the type such as Aristoflex HMS sold by the company Clariant;

- anionic, cationic, amphoteric or nonionic chitin or chitosan polymers;

- cellulose polymers and derivatives, preferably other than alkylcellulose, chosen from hydroxyethylcellulose, hydroxypropylcellulose, hydroxymethylcellulose, ethylhydroxyethylcellulose and carboxymethylcellulose, and also quaternized cellulose derivatives;

- Starch polymers and derivatives, eventually modified;

- vinyl polymers, for instance polyvinylpyrrolidones, copolymers of methyl vinyl ether and of malic anhydride, the copolymer of vinyl acetate and of crotonic acid,

copolymers of vinylpyrrolidone and of vinyl acetate; copolymers of vinylpyrrolidone and of caprolactam; polyvinyl alcohol;

- optionally modified polymers of natural origin, such as galactomannans and derivatives thereof, such as konjac gum, gellan gum, locust bean gum, fenugreek gum, karaya gum, gum tragacanth, gum arabic, acacia gum, guar gum, hydroxypropyl guar, hydroxypropyl guar modified with sodium methylcarboxylate groups (Jaguar XC97-1, Rhodia), hydroxypropyltrimethylammonium guar chloride, and xanthan derivatives;

- alginates and carrageenans;

- glycoaminoglycans, hyaluronic acid and derivatives thereof;

- mucopolysaccharides such as hyaluronic acid and chondroitin sulfates, and mixtures thereof;

and the mixtures thereof.

Preferably, the hydrophilic polymers according to the invention are selected from the group consisting of polysaccharides and derivatives, acrylic or methacrylic acid homopolymers or copolymers or salts and esters thereof, and their mixture.

Said polysaccharides and derivatives are preferably selected from chitosan polymers, chitin polymers, cellulose polymers, starch polymers, galactomannans, alginates, carrageenans, mucopolysaccharides, and their derivatives, and the mixture thereof.

According to one particularly preferred embodiment, said polysaccharides and their derivatives are preferably selected from the ones including one type of ose or several type of ose(s), preferably several types of oses., in particular at least D-Glucose unit(s) as ose(s), preferably starch polymers, cellulose polymers, and derivatives, and the mixture thereof.

According to a preferred embodiment, the capsule contains at least starch and its derivatives, in particular corn starch, homo- and /or co-polymer of methacrylic acid and/or methacrylic acid and their ester, in particular polymethyl methacrylate, and/or cellulose and its derivative.

Starch usable according to the present invention is usually issued from vegetable raw materials, such as rice, soybeans, potatoes, or corn. Starch can be unmodified or (by analogy with cellulose) modified starch.

Preferred homo- and /or co-polymer of methacrylic acid and/or methacrylic acid ester are those wherein the copolymer of methyl methacrylate and ethyl acrylate has a molecule weight from 750 to 850 kDa.

Cellulose derivatives include, for example, alkali celluloses, carboxymethyl cellulose (CMC), cellulose esters and ethers, and aminocelluloses.

According to a preferred embodiment, the capsule contains at least starch derivative, in particular corn starch, polymethyl methacrylate and/or cellulose derivative.

The polymer may be in one or several layer(s).

The polymer may represent from 0,5 to 20% by weight of the microcapsule, in particular from 1 to 10% by weight of the microcapsule.

As previously stated, the different layers forming the coating may be based on identical or different polymers. Advantageously, they will be formed from the same polymer.

In contrast, the layers will be advantageously differently coloured.

This different colour may be obtained through the use of different colorants but also the use of different concentrations in at least one colorant when the colorant will be the same for two layers.

In a particular embodiment, the outer layer contains at least one colorant.

In another embodiment, the outer layer does not contain any colorant.

### **Colorant(s)**

As previously stated, "colorant" include any organic or inorganic pigment or colorant approved for use in cosmetics by CTFA and the FDA used in cosmetic formulations.

Thus the term "colorant" refers to organic pigments such as synthetic or natural dyes selected from any of the well known FD&C or D&C dyes, inorganic pigments such as metal oxides, or lakes such as the ones based on cochineal carmine, barium, strontium, calcium or aluminum and any combination (blend) thereof. Such colorants are detailed here-after.

In a particular embodiment, the colorant may be water-soluble or water-dispersible.

In another embodiment, the colorant useful according to the present invention may be oil-soluble or oil-dispersible or with limited solubility in water.

In preferred embodiments, the colorant is an inorganic pigment, more preferably a metal oxide.

Advantageously, the colorants of the multi-layer microcapsules are primary metal oxides selected from iron oxides, titanium dioxide, aluminum oxide, zirconium oxides, cobalt oxides, cerium oxides, nickel oxides, tin oxide or zinc oxide, or composite oxides, more preferably an iron oxide selected from red iron oxide, yellow iron oxide or black iron oxide, or a mixture thereof.

The layer(s) may also contain lakes corresponding to an organic colorant secured to a substrate. Such (a) lake(s) is (are) advantageously chosen among the here-below material, and their mixture(s):

- carmin of cochenille;

- organic pigments of azoïques, anthraquinoniques, indigoïdes, xantheniques, pyreniques, quinoliniques, de triphenylmethane, de fluorane colorants; Among the organic pigments may be cited those known under the following trademark references : D&C Blue n° 4, D&C Brown n° 1, D&C Green n° 5, D&C Green n° 6, D&C Orange n° 4, D&C Orange n° 5, D&C Orange n°10, D&C Orange n° 11, D&C Red n° 6, D&C Red n° 7, D&C Red n° 17, D&C Red n°21, D&C Red n° 22, D&C Red n° 27, D&C Red n° 28, D&C Red n° 30, D&C Red n° 31, D&C Red n° 33, D&C Red n° 34, D&C Red n° 36, D&C Violet n° 2, D&C Yellow n° 7, D&C Yellow n° 8, D&C Yellow n° 10, D&C Yellow n° 11, FD&C Blue n° 1, FD&C Green n° 3, FD&C Red n° 40, FD&C Yellow n° 5, FD&C Yellow n° 6 ;

- the insoluble salts of sodium, potassium, calcium, baryum, aluminum, zirconium, strontium, titanium, of acid colorants such as azoïques, anthraquinoniques, indigoïdes, xantheniques, pyreniques, quinoliniques, de triphenylmethane, de fluorane colorants, these colorants may include at least one carboxylic or sulfonic acid group.

The organic lakes may also be secured to an organic support such as colophane or aluminum benzoate.

Among the organic lakes, we may in particular cite those known under the following names : D&C Red n° 2 Aluminum lake, D&C Red n° 3 Aluminum lake, D&C Red n° 4 Aluminum lake, D&C Red n° 6 Aluminum lake, D&C Red n° 6 Barium lake, D&C Red n° 6 Barium/Strontium lake, D&C Red n° 6 Strontium lake, D&C Red n° 6 Potassium lake, D&C Red n° 6 Sodium lake, D&C Red n° 7 Aluminum lake, D&C Red n° 7 Barium lake, D&C Red n° 7 Calcium lake, D&C Red n° 7 Calcium/Strontium lake, D&C Red n° 7 Zirconium lake, D&C Red n° 8 Sodium lake, D&C Red n° 9 Aluminum lake, D&C Red n° 9 Barium lake, D&C Red n° 9 Barium/Strontium lake, D&C Red n° 9 Zirconium lake, D&C Red n° 10 Sodium lake, D&C Red n° 19 Aluminum lake, D&C Red n° 19 Barium lake, D&C Red n° 19 Zirconium

lake, D&C Red n° 21 Aluminum lake, D&C Red n° 21 Zirconium lake, D&C Red n° 22 Aluminum lake, D&C Red n° 27 Aluminum lake, D&C Red n° 27 Aluminum/Titanium/Zirconium lake, D&C Red n° 27 Barium lake, D&C Red n° 27 Calcium lake, D&C Red n° 27 Zirconium lake, D&C Red n° 28 Aluminum lake, D&C Red n° 28 Sodium lake D&C Red n° 30 lake, D&C Red n° 31 Calcium lake, D&C Red n° 33 Aluminum lake, D&C Red n° 34 Calcium lake, D&C Red n° 36 lake, D&C Red n° 40 Aluminum lake, D&C Blue n° 1 Aluminum lake, D&C Green n° 3 Aluminum lake, D&C Orange n° 4 Aluminum lake, D&C Orange n° 5 Aluminum lake, D&C Orange n° 5 Zirconium lake, D&C Orange n° 10 Aluminum lake, D&C Orange n° 17 Barium lake, D&C Yellow n° 5 Aluminum lake, D&C Yellow n° 5 Zirconium lake, D&C Yellow n° 6 Aluminum lake, D&C Yellow n° 7 Zirconium lake, D&C Yellow n° 10 Aluminum lake, FD&C Blue n° 1 Aluminum lake, FD&C Red n° 4 Aluminum lake, FD&C Red n° 40 Aluminum lake, FD&C Yellow n° 5 Aluminum lake, FD&C Yellow n° 6 Aluminum lake.

The chemistry material corresponding to each of these organic colorants previously cited are mentioned in the book called « International Cosmetic Ingredient Dictionary and Handbook », Edition 1997, pages 371 à 386 et 524 à 528, published by « The Cosmetic, Toiletry, and Fragrance Association », of whom the content is hereby incorporated by reference in the present specification.

According to a preferred embodiment, the lake(s) is selected from carmin of cochenille and the insoluble salts of sodium, potassium, calcium, baryum, aluminum, zirconium, strontium, titanium, of acid colorants such as azoïques, anthraquinoniques, indigoïdes, xantheniques, pyreniques, quinoliniques, de triphenylmethane, fluorine colorants, being given that these colorants may include at least one carboxylic or sulfonic acid group, and their mixture.

According to a preferred embodiment, the lake(s) is selected from carmin of cochenille and the insoluble salts of sodium, calcium, aluminum, and their mixture.

As lake incorporating carmin we may cite the commercial references: CARMIN COVALAC W 3508, CLOISONNE RED 424C and CHROMA-LITE MAGENTA CL4505.

The insoluble aluminum salts are preferably selected from FDC Yellow N°5 aluminum lake, the FDC Blue N°1 aluminum lake, the FDC Red N°40 aluminum lake, the FDC Red N°30 aluminum lake, the FDC Green N°5 aluminum lake, and their mixtures. As compound incorporating such inorganic lake may notably be cited the commercial references: INTENZA FIREFLY C91-1211, INTENZA AZURE ALLURE C91-1251, INTENZA THINK PINK C91-1236.

The insoluble calcium salts are preferably selected from Red N°7 calcium lake. As compound incorporating such inorganic lake may notably be cited the commercial references: INTENZA MAGENTITUDE C91-1234, INTENZA HAUTE PINK C91-1232, INTENZA RAZZLED ROSE C91-1231, INTENZA AMETHYST FORCE C91-7231, INTENZA PLUSH PLUM C91-7441, INTENZA ELECTRIC CORAL C91-1233, FLORASOMES-JOJOBA-SMS-10% CELLINI RED-NATURAL and their mixture.

The insoluble sodium salts are preferably selected from Red N°6 sodium lake and Red N°28 sodium lake, and their mixture. E As compound incorporating such inorganic lake may notably be cited the commercial references : INTENZA MANGO TANGO C91-1221 et INTENZA NITRO PINK C91-1235.

In preferred embodiments, the colorant is an inorganic colorant.

In a preferred embodiment, the colorant is a metallic oxide. Such metallic oxide is preferably selected from iron oxides, titanium oxides, and mixtures thereof.

The color-changing compositions of the invention may comprise a mixture of two or more colorants, either encapsulated individually in microcapsules and/or one or more blends of colorants encapsulated within the multi-layer microcapsules.

In accordance with this specific embodiment, each layer from the microcapsule contains at least one specific colorant or a specific blend of colorant(s).

In accordance with this specific embodiment, the color-changing composition of the invention comprises two or more microcapsules of the invention having different colors,

A person skilled in the art knows how to choose colorants and combinations of colorants to produce a desired color effect or color change.

As stated previously, the microcapsules of the invention contain preferably at least titanium dioxide and/or iron oxides in their coating, preferably at least titanium dioxide

According to a specific embodiment, the outer layer of said microcapsules contains titanium dioxide and more preferably as only colorant.

According to a specific embodiment, the outer layer of said microcapsules contains organic pigments or iron oxides.

The colorants may be present in amounts ranging from 20% to 90%, preferably from 30% to 80%; in particular from 50% to 75% by weight relative to the microcapsule.

**Lipid based material**

The inner and outer organic layers may also include advantageously at least one lipid-based material.

According to a particular embodiment of this invention, such lipid based material may have amphiphilic properties, that is to say having an apolar part and a polar part.

Such lipid-based material can include at least one or several C<sub>12</sub>-C<sub>22</sub> fatty acids chain such as selected from stearic acid, palmitic acid, oleic acid, linoleic acid, linolenic acid, etc and mixtures thereof. Preferably these fatty acids chains are hydrogenated. Eventually, these fatty acid chains may be the apolar part of a lipid based material.

Such lipid based material is preferably selected from phospholipids. These phospholipids are preferably selected from phosphoacylglycerol, more preferably selected from lecithins, and in particular hydrogenated lecithins.

The lipid based material may represent from 0,05 to 5% by weight of the microcapsule, in particular from 0,1 to 1% by weight of microcapsule.

By combining three or more compounds (ex: sugar alcohols, polymers, lipid-based material) in the microcapsule of different hardness and/or water solubility, it is possible to adjust the time required for colorant-encapsulated microcapsules to break down on the skin so that, by varying the method or intensity of application onto the skin, it is possible to adjust the preferred colouration or gradation pattern.

Thus, according to a preferred embodiment, the multi-layers coating contains at least starch as polymer with at least one lipid-based material and preferably lecithin.

According to an advantageous embodiment the microcapsules according to the invention includes at least one monosaccharide or its derivatives and at least polysaccharide or its derivatives.

According to a preferred embodiment, the microcapsules include a core comprising a monosaccharide derivatives and a coating comprising a polysaccharides (or its derivatives) including one type of ose or several type of ose(s), preferably several types of oses.

According to a more preferably embodiment, the microcapsules include a core comprising a monosaccharide polyol, preferably selected from mannitol, erythritol, xylitol, sorbitol, and a coating comprising a polysaccharides (or its derivatives) including as ose(s) at least D-Glucose unit(s).

According to a preferred embodiment, the microcapsules include three or more colorants in different layers.

According to a preferred embodiment, the microcapsules additionally includes lipid based material chosen from phospholipids, advantageously selected from phosphoacylglycerol and in particular lecithins.

As examples of microcapsules to be used in the composition of the invention, we may refer to the following microcapsules produced by KPT under the commercial names :

- Magic 60-WP0105 from Korea Particle Technology: pink spherical microcapsule containing titanium dioxide, mannitol, hydrogenated lecithin, synthetic fluorphlogopite, red 30 lake, zea mays (corn) starch, tin oxide, having 60-200 Mesh particle size;
- Magic50-BW0105 from Korea Particle Technology: ash gray spherical microcapsule containing mannitol, iron oxide red, iron oxide yellow, iron oxide black, hydrogenated lecithin, titanium dioxide, zea mays (corn) starch, having 60-200 Mesh particle size.

### **GEL FORMULATION**

The composition is in the form of a gel and in particular a transparent gel, and comprising from 0,1 to 10% by weight relative to the weight of the composition of microcapsules.

Preferably, the viscosity of the gel according to the invention is superior or equal to 20UD (Mobile 3) by Rheomat at 25°C.

The viscosity is generally measured at 25°C with a viscosimeter RHEOMAT RM 180 with Mobile 3 adapted to the viscosity of the product to be tested (mobile is chosen for having a measure between 10 and 90 for UD Unit Deviation), the measure being made after 10mn rotating the mobile inside the composition, with a cisaillement from 200s<sup>-1</sup>. The UD values may then be converted in Poises (1 Poise= 0,1Pa.s) with a correspondence table.

More preferably, the composition contains a gelified aqueous phase.

Hydrophilic gelling agents that may be mentioned in particular include water-soluble or water-dispersible thickening polymers. These polymers may be chosen especially from:

- modified or unmodified carboxyvinyl polymers, such as the products sold

- under the name Carbopol (CTFA name: Carbomer) by the company Goodrich; polyacrylates
- polymethacrylates such as the products sold under the names Lubrajel and Norgel by the company Guardian or under the name Hispagel by the company Hispano Chimica;
  - polyacrylamides; optionally crosslinked and/or
    - neutralized 2-acrylamido-2-methylpropanesulfonic acid polymers and copolymers, for instance the poly(2-acrylamido-2-methylpropanesulfonic acid) sold by the company Clariant under the name Hostacerin AMPS (CTFA name: ammonium polyacryldimethyltauramide);
    - crosslinked anionic copolymers of acrylamide and of AMPS, which are in the form of a W/O emulsion, such as those sold under the name Sepigel 305 (CTFA name: : Polyacrylamide/C13-14 isoparaffin/Laureth-7) and under the name Simulgel 600 (CTFA name: Acrylamide/Sodium acryloyldimethyltaurate copolymer/Isohexadecane/Polysorbate 80) by the company SEPPIC;
  - polysaccharide biopolymers, for instance xanthan gum, guar gum, carob gum, acacia gum, scleroglucans, chitin and chitosan derivatives, carrageenans, gellans, alginates,
  - celluloses such as microcrystalline cellulose, carboxymethylcellulose, hydroxymethylcellulose and hydroxypropylcellulose; and mixtures thereof. Preferably, these polymers may be chosen from Acrylates/C10-30 Alkyl Acrylate Crosspolymer such as, Carbopol ultrez 20, Carbopol ultrez 21, Permulen TR-1, Permulen TR-2, Carbopol 1382 , Carbopol ETD 2020, Carbomer such as Synthalen K, carbopol 980, Ammonium acryloyldimethyl Taurate/Steareth-8 Methacrylate copolymer such as Aristoflex SNC, Acrylates copolymer such as Carbopol Aqua SF-1, Ammonium acryloyldimethyl taurate/steareth-25 Methacrylate Crosspolymer such as Aristoflex HMS, Ammonium acryloyldimethyl taurate such as Arisfoflex AVC, and xanthan gum such as Keltrol CG, etc, and also any polymers which contribute not only to sustain a proper viscosity, to further make capsule suspension very well and further to make it stable in shelf lives, but also to deliver a transparency.

These gelling agents may be present in an amount ranging for example from 0.001 to 10 % by weight, preferably 0.01 to 5% by weight and more preferably from 0.05 to 3% by weight relative to the total weight of said composition.

According to a specific embodiment, the aqueous phase of the composition contains at least one neutralized 2-acrylamido-2-methylpropanesulfonic acid polymers and copolymers and one polysaccharide biopolymer.

More preferably the aqueous gel is transparent.

The expression "transparent aqueous medium" means a medium allowing light to pass without causing deviation by refraction or reflection. The transparency of the aqueous medium can be measured using a turbidimeter. The portable Turbidimeter 2100P<sup>®</sup> Model from HACH company may be used, for example, for measuring the ranges of transparency of the composition. The composition is considered to be transparent when the measured value of turbidity is between 0 and 250 NTU and is considered as a translucent for a value of turbidity from 250 to 1000 NTU.

The transparent compositions, when placed in front of a 0.01 m thick black line with diameter of 2 mm drawn on a white sheet, reveal this black line, as opposed to an opaque composition that is to say, not transparent which would not allow it.

The changing color composition in the form of a transparent gel according to the invention preferably comprises water and multi-layered microcapsules containing releasable colorant(s).

In a first preferred embodiment, the transparent gel according to the invention comprises at least one hydrophilic or lipophilic gelling agent and at least one water soluble emollient(s) and/or lipid(s) with a polar moiety.

In a first preferred embodiment, the transparent gel according to the invention comprises at least two types of different multi-layered microcapsules containing releasable colorant(s).

The transparent gel according to the invention, which is preferably a BB product or a foundation, provides very strong moisturizing sensation, transparent, cleaning bulk appearance with very comfortable feeling during application and sheer natural make-up result after application. These features help to deliver both skincare efficacy perception (watery, moisturization and transparent) as well as make-up efficacy (proper coverage).

Advantageously the transparent gel contains a swelling agent, in particular as disclosed here-after, this agent allows a better swelling of the microcapsules thus rendering the microcapsules easier to break during application. Water, alcohols, glycols

polyols may be used as swelling agent. Examples of swelling agents are disclosed above.

The moisturization may further be enhanced by introduction of one or more water soluble emollient(s) and/or lipid(s) with a polar moiety. PEG modified silane and silicone such as Bis-PEG-18 Methyl ether dimethyl silane, and/or PEG modified ester such as PEG-7 Oliviate, PEG-7 Glyceryl Cocoate, PEG-30 Glyceryl Cocoate, PEG-80 Glyceryl Cocoate, may be used to enhance moisturization.

A solubilizer may also be added in order to keep the properties of the transparent gel on storage, in particular to make emollients solubilized in water phase, to make and keep gel transparent and stable in shelf lives. Polysorbate 20, PEG-60 hydrogenated castor oil may be mentioned as examples of solubilizers particularly of solubilizers of the above mentioned water soluble emollient(s).

The transparent gel according to the invention presents a very beautiful, clean and tidy appearance, with pigments releasing during application without any particle feeling. Makeup results are perfectly and evenly provided after application.

A preferred embodiment of the transparent gel according to the invention comprises:

at least one of the polymers chosen from Acrylates/C10-30 Alkyl Acrylate Crosspolymer such as Permulen TR-1, Permulen TR-2, Carbopol 1382, Carbopol ETD 2020, preferably in a concentration from 0 to 10 % wgt, more preferably from 0 to 2% wgt, Carbomer such as Synthalen K, carbopol 980 preferably in a concentration from 0 to 10 % wgt, more preferably from 0 to 2% wgt, Ammonium acryloyldimethyl Taurate/Steareth-8 Methacrylate copolymer such as Aristoflex SNC, preferably in a concentration from 0 to 10 % wgt, more preferably from 0 to 2% wgt, Acrylates copolymer such as Carboplol Aqua SF-1 preferably in a concentration from 0 to 10 % wgt, more preferably from 0 to 2% wgt, Ammonium acryloyldimethyl taurate/steareth-25 Methacrylate Crosspolymer such as Aristoflex HMS, preferably in a concentration from 0 to 10 % wgt, more preferably from 0 to 2% wgt, Ammonium acryloyldimethyl taurate such as Arisfoflex AVC, preferably in a concentration from 0 to 10 % wgt, more preferably from 0 to 4% wgt and xanthan gum such as Keltrol CG, preferably in a concentration from 0 to 10 % wgt, more preferably from 0 to 4% wgt.

Moreover the transparent gel may contain at least one of the following swelling agent, water such as deionized water, preferably in a concentration from 0 to 90 % wgt, more preferably from 30 to 70% wgt, alcohols preferably in a concentration from 0 to 50 % wgt, more preferably from 1 to 20% wgt, glycols such as propyl glycol,

butyl glycol, preferably in a concentration from 0 to 50 % wgt, more preferably from 1 to 15% wgt, polyols such as glycerin, tetraols, preferably in a concentration from 0 to 50 % wgt, more preferably from 1 to 10% wgt.

In addition, the transparent gel may contain at least one water soluble emollients chosen from Bis-PEG-18 Methyl ether dimethyl silane, PEG-7 Oliviate, PEG-7 Glyceryl Cocoate, PEG-30 Glyceryl Cocoate, PEG-80 Glyceryl Cocoate, in a concentration from 0 to 20 % wgt, more preferably from 0 to 5% wgt, and at least one solubilizers such as polysorbate 20, PEG-60 hydrogenated castor oil, in a concentration from 0 to 10 % wgt, more preferably from 1 to 5% wgt .

Microcapsules such as Magic 60-WP0105, and Magic50-BW0105 from Korea Particle Technology in a concentration from 0,1 to 10 % wgt, more preferably from 1 to 10% wgt may be introduced at last step with gentle stirring but without side scrapper after gel is made.

In the case of caring composition, the composition according to the invention comprises from 0.1% to 5% by weight and preferably from 0.1% to 3% by weight of microcapsules relative to the total weight of the said composition.

The obtained transparent gel with microcapsules present a pure and clean appearance, with perfect stability under -20/20°C (5 cycles), room temperature (25°C, 2 months), 37°C (2 months) and 45°C (2 months). The microcapsules release pigments during application without any particle feeling. Makeup results are perfectly and evenly provided after application.

The transparent gel could also be slightly colored.

In this case, the transparent gel comprises at least one non-entrapped colorant, in particular as disclosed here-after, preferably in an amount of less than 1% by weight based on the total weight of the total composition.

### **SWELLING AGENT**

The microcapsules of the invention need to be in contact with a swelling agent to be softened when applied on the keratinic material. These compounds are particularly advantageous for imparting and/or improving deformability to the microcapsules of the invention.

The composition of the invention contains microcapsules as defined above and at least one swelling agent.

The swelling agent is preferably present in an amount of at least 3% by weight, preferably at least 5% by weight, more preferably at least 8% by weight and

advantageously at least 10 % by weight relative to the weight of the composition of at least one swelling agent.

The composition of the invention will generally comprise swelling agent(s) in amount ranging from 3% to 50% by weight, preferably from 5% to 45% by weight and more preferably from 10% to 45% by weight relative to the total weight of the composition.

The term 'swelling agent' according to the invention is an agent able to swell the compounds of the core and/or the layers.

Such 'swelling agent' according to the invention may be chosen from:

- compounds comprising at least one –OH function chosen from water, C<sub>2</sub>-C<sub>8</sub> monoalcohols, glycols and polyols.

In a preferred embodiment, the swelling agent is chosen from C<sub>2</sub>-C<sub>8</sub> monoalcohols, glycols and polyols.

In a preferred embodiment, the composition of the invention comprises at least one C<sub>2</sub>-C<sub>8</sub> monoalcohols.

In another preferred embodiment, the composition of the invention comprises at least one polyol or glycol.

In another preferred embodiment, the composition of the invention comprises at least one alcohol and at least one polyol or glycol.

### **Monoalcohols or Lower alcohols**

Monoalcohol or lower alcohol that is suitable for use in the invention may be a compound of linear, branched or cyclic, saturated or unsaturated alkyl type, bearing only one –OH function.

The lower monoalcohols that are advantageously suitable for formulating a composition according to the present invention are those especially containing from 2 to 5 carbon atoms such as ethanol, propanol, butanol, isopropanol, isobutanol preferably ethanol and/or isopropanol and more preferably at least ethanol.

A composition of the invention may comprise at least 1% by weight, preferably at least 2 % by weight and better still from 3% to 8% by weight, preferably from 4% to 6% by weight of mono-alcohol(s) relative to the total weight of said composition.

Lower monoalcohols such as ethanol can be advantageous in many ways in the field of makeup and/or care of keratin material(s).

Such compounds are particularly useful for providing a fresh feeling to the user when he applied on the skin, a composition of the invention.

Furthermore, such a feeling of freshness, pleasant as such to the user, may also advantageously allow to activate blood circulation in the skin where it is felt, especially in the skin surrounding the eyes which forms a particularly well vascularized area. The fresh feeling accompanying the application of these lower monoalcohols thus reduces puffiness and dark circles present in this part of the face due to the high vascularity and thinness in this part of the face.

The application of lower monoalcohols can also advantageously avoid the need to apply other cooling agents such as menthol, ethyl menthane carboxamide, menthyl lactate, menthoxypropanediol around the eyes, which are generally raw material irritating to the eyes.

Furthermore, the lower monoalcohols such as ethanol allow to dissolve active agents, especially keratolytic agents, such as, for example, salicylic acid and its derivatives.

A composition according to the invention may advantageously comprise at least one lower monoalcohol.

### **Polyols and glycols**

For the purposes of the present invention, the term "polyol" should be understood as meaning any organic molecule comprising at least two free hydroxyl groups. The term "polyol" according to the invention does not encompass monosaccharide-alcohol disclosed above.

Preferably, a polyol in accordance with the present invention is present in liquid form at room temperature.

A polyol that is suitable for use in the invention may be a compound of linear, branched or cyclic, saturated or unsaturated alkyl type, bearing on each alkyl chain at least two –OH functions, in particular at least three –OH functions and more particularly at least four –OH functions.

The polyols that are advantageously suitable for formulating a composition according to the present invention are those especially containing from 2 to 32 carbon atoms preferably 2 to 20 atoms and more preferably 2 to 16 carbon atoms, advantageously 2 to 10, more advantageously 2 to 6.

According to another embodiment, a polyol that is suitable for use in the invention may be advantageously chosen from polyethylene glycols.

According to one embodiment, a composition of the invention may comprise a mixture of polyols.

Advantageously, the polyol may be chosen from polyhydric alcohols, preferably of C<sub>2</sub>-C<sub>8</sub> and more preferably C<sub>3</sub>-C<sub>6</sub>. The polyol may be chosen from glycerol, pentaerythritol, trimethylolpropane, ethylene glycol, propylene glycol, 1,3-butylene glycol, 1,3-propanediol, pentylene glycol, hexylene glycol, isoprene glycol, dipropylene glycol, diethylene glycol and diglycerol, and mixtures thereof, glycerol and derivatives thereof, polyglycerols, such as glycerol oligomers, for instance diglycerol, and polyethylene glycols, glycol ethers (especially containing from 3 to 16 carbon atoms) such as mono-, di- or tripropylene glycol (C<sub>1</sub>-C<sub>4</sub>)alkyl ethers, mono-, di- or triethylene glycol (C<sub>1</sub>-C<sub>4</sub>)alkyl ethers, and mixtures thereof.

Particularly, the polyol is selected from the group consisting in glycerol, glycols, preferably propylene glycol, butylene glycol, pentylene glycol, hexylene glycol, dipropylene glycol, diethylene glycol, glycol ethers, preferably mono-, di- or tripropylene glycol of alkyl(C<sub>1</sub>-C<sub>4</sub>)ether or mono-, di- or triethylene glycol of alkyl(C<sub>1</sub>-C<sub>4</sub>)ether, and mixtures thereof.

According to one preferred embodiment of the invention, the said polyol is chosen from ethylene glycol, pentaerythritol, trimethylolpropane, propylene glycol, butylene glycol, glycerol, polyglycerols and polyethylene glycols, and mixtures thereof.

According to one particular embodiment, the composition of the invention comprises at least butylene glycol, glycerol or a mixture thereof.

In a preferred embodiment, the composition comprises at least glycerol.

According to one particular embodiment, the composition of the invention comprises glycerol as sole polyol.

A composition according to the invention may advantageously comprise at least 10% by weight, preferably between 10 and 45% and in particular between 10 and 40 of polyol(s) or glycols, preferably one C<sub>2</sub>-C<sub>32</sub> polyol and/or glycol, based on weight of the composition .

### **COSMETIC MEDIUM AND ADDITIONAL INGREDIENTS**

The gel composition according to the invention is cosmetically acceptable that is it contains a physiologically acceptable medium which is non toxic and appropriate to be applied on the keratin material of human beings.

“Cosmetically acceptable” in the sense of the present invention means a composition with pleasant appearance, odor or feeling.

The “physiologically acceptable medium” is generally adapted to the form of under which the composition is intended to be conditioned.

Depending upon the form and the aim of the skin care or make-up preparation, the composition of the invention will comprise, in addition to the microcapsules containing colorant, further additional cosmetic ingredient(s) such as the ones selected from surfactants, fillers, gelifying agents, thickening agents, film forming agents, polymers, preservatives, silicone elastomere, self-tanning agents, additional non-entrapped colorants, actives, UV filters and mixtures thereof.

It is a matter of routine operations for a person skilled in the art to adjust the nature and amount of the additives present in the compositions in accordance with the invention such that the desired cosmetic properties thereof are not thereby affected.

Some of these conventional ingredients are detailed here-after.

### **Aqueous phase**

The composition according to the invention contains at least one aqueous phase.

The aqueous phase comprises water and, where appropriate, a water-soluble solvent.

In the present invention, the term “water-soluble solvent” denotes a compound that is liquid at room temperature and water-miscible (miscibility with water of greater than 50% by weight at 25°C and atmospheric pressure).

The water-soluble solvents that may be used in the composition of the invention may also be volatile.

As said, the composition of the invention contains at least 3% by weight, preferably at least 5% by weight, more preferably at least 8% by weight and advantageously at least 10 % by weight relative to the weight of the composition of at least one swelling agent preferably chosen from compounds comprising a –OH function chosen from water, C<sub>2</sub>-C<sub>8</sub> monoalcohols, glycols and polyol. It also may contain C<sub>4</sub> ketones and C<sub>2</sub>-C<sub>4</sub> aldehydes.

The aqueous phase (water and optionally the water-miscible solvent) may be present in a content ranging from 10% to 99% by weight, preferably from 20% to 95% by weight and better still from 30% to 80% by weight relative to the total weight of the said composition.

Advantageously, the aqueous phase may be present in a content ranging from 40% to 80% by weight, preferably from 50% to 80% by weight relative to the total weight of the said composition.

### **Tanning agents**

For the purposes of the present invention, the expression "skin self-tanning agent" means a compound that is capable of producing, on contact with the skin, a coloured reaction with the free amine functions present in the skin, such as amino acids, peptides or proteins.

Other characteristics, aspects and advantages of the present invention will emerge on reading the detailed description that follows.

The self-tanning agents are generally chosen from certain monocarbonyl or polycarbonyl compounds, for instance isatin, alloxan, ninhydrin, glyceraldehyde, mesotartaric aldehyde, glutaraldehyde, erythrulose, pyrazoline-4,5-dione derivatives as described in patent application FR 2 466 492 and WO 97/35842, dihydroxyacetone (DHA), and 4,4-dihydroxypyrazolin-5-ones as described in patent application EP 903 342. DHA will preferably be used.

DHA may be used in free and/or encapsulated form, for example in lipid vesicles such as liposomes, especially described in patent application WO 97/25970.

The self-tanning agent(s) is (are) generally present in proportions ranging from 0.1% to 15% by weight, preferably from 0.2% to 10% by weight and more preferentially from 1% to 8% by weight relative to the total weight of the composition.

### **Silicone Elastomers**

According to the present invention, compositions may comprise at least one silicone elastomer. Any suitable silicone elastomer can be used in accordance with the present invention. Suitable silicone elastomers include, for example, emulsifying silicone elastomers such as polyglycerolated and/or hydrophilic emulsifying silicone elastomers such as alkoxyated silicone elastomers, and non-emulsifying silicone elastomers. Such silicone elastomers can be spherical or non-spherical.

#### **Polyglycerolated Silicone Elastomers**

Suitable polyglycerolated silicone elastomers include, for example, crosslinked elastomeric organopolysiloxanes that may be obtained by a crosslinking addition reaction of diorganopolysiloxane containing at least one hydrogen atom linked

to silicon and of polyglycerolated compounds containing ethylenically unsaturated groups, especially in the presence of a platinum catalyst.

Polyglycerolated silicone elastomers that may be used include, but are not limited to, those sold under the names "KSG-710", "KSG-810", "KSG-820", "KSG-830" and "KSG-840" by the company Shin-Etsu. Suitable polyglycerolated silicone elastomers are also disclosed in U.S. serial no. 11/085,509, filed March 22, 2005 (published as U.S. patent application publication no. 2005/0220728), the entire disclosure of which is hereby incorporated by reference.

#### Hydrophilic Emulsifying Silicone Elastomers

The term "hydrophilic emulsifying silicone elastomer" means a silicone elastomer comprising at least one hydrophilic chain other than a polyglycerolated chain as described above.

In particular, the hydrophilic emulsifying silicone elastomer may be chosen from polyoxyalkylenated silicone elastomers.

Suitable polyoxyalkylenated elastomers are described in patents U.S. Pat. No. 5,236,986, U.S. Pat. No. 5,412,004, U.S. Pat. No. 5,837,793 and U.S. Pat. No. 5,811,487.

Suitable polyoxyalkylenated silicone elastomers that may be used include those sold under the names "KSG-21", "KSG-20", "KSG-30", "KSG-31", "KSG-32", "KSG-33", "KSG-210", "KSG-310", "KSG-320", "KSG-330", "KSG-340" and "X-226146" by the company Shin-Etsu, or "DC9010" and "DC9011" by the company Dow Corning.

Suitable hydrophilic emulsifying silicone elastomers are also disclosed in U.S. serial no. 11/085,509, filed March 22, 2005 (published as U.S. patent application publication no. 2005/0220728).

#### Non-Emulsifying Silicone Elastomers

The term "non-emulsifying" defines elastomers not containing a hydrophilic chain, such as polyoxyalkylene or polyglycerolated units.

The non-emulsifying silicone elastomer is preferably an elastomeric crosslinked organopolysiloxane that may be obtained by a crosslinking addition reaction of diorganopolysiloxane containing at least one hydrogen linked to silicon and of diorganopolysiloxane containing ethylenically unsaturated groups linked to silicon, especially in the presence of a platinum catalyst; or by dehydrogenation crosslinking coupling reaction between a diorganopolysiloxane containing hydroxyl end groups and a diorganopolysiloxane containing at least one hydrogen linked to silicon, especially in the presence of an organotin compound; or by a crosslinking coupling reaction of a

diorganopolysiloxane containing hydroxyl end groups and of a hydrolysable organopolysilane; or by thermal crosslinking of organopolysiloxane, especially in the presence of an organoperoxide catalyst; or by crosslinking of organopolysiloxane via high-energy radiation such as gamma rays, ultraviolet rays or an electron beam.

Suitable non-emulsifying silicone elastomers are described in patent applications JP61-194009 A, EP0242219 A, EP0295886 A and EP0765656 A.

Suitable non-emulsifying silicone elastomers that may be used include, but are not limited to, those sold under the names "DC 9040", "DC 9041", "DC 9509", "DC 9505" and "DC 9506" by the company Dow Corning.

Suitable non-emulsifying silicone elastomers are also disclosed in U.S. serial no. 11/085,509, filed March 22, 2005 (published as U.S. patent application publication no. 2005/0220728).

The non-emulsifying silicone elastomer may also be in the form of elastomeric crosslinked organopolysiloxane powder coated with silicone resin, especially with silsesquioxane resin, as described, for example, in patent U.S. Pat. No. 5,538,793, the entire content of which is herein incorporated by reference. Such elastomers are sold under the names "KSP-100", "KSP-101", "KSP-102", "KSP-103", "KSP-104" and "KSP-105" by the company Shin-Etsu.

Other elastomeric crosslinked organopolysiloxanes in the form of powders include hybrid silicone powders functionalized with fluoroalkyl groups, sold especially under the name "KSP-200" by the company Shin-Etsu; hybrid silicone powders functionalized with phenyl groups, sold especially under the name "KSP-300" by the company Shin-Etsu.

The silicone elastomer may be present in the compositions of the present invention in an amount of from 0.1% to 95% by weight, preferably from 0.1% to 75% by weight, more preferably from 0.1 to 50% by weight, more preferably from 0.1% to 40% by weight, more preferably from 0.5% to 30% by weight, more preferably from 0.5% to 25% by weight, more preferably from 1% to 20%, more preferably from 1% to 15% and even more preferably from 3% to 10% by weight based on the weight of the composition.

### **Film-forming agents**

#### **Silicone polyamide**

The compositions according to the invention comprise at least one silicone polyamide.

The silicone polyamides of the composition are preferably solid at room temperature (25°C) and atmospheric pressure (760 mmHg).

The silicone polyamides of the composition of the invention may be polymers of the polyorganosiloxane type, for instance those described in documents US-A-5 874 069, US-A-5 919 441, US-A-6 051 216 and US-A-5 981 680. According to the invention, the silicone polymers may belong to the following two families:

(1) polyorganosiloxanes comprising at least two amide groups, these two groups being located in the polymer chain, and/or

(2) polyorganosiloxanes comprising at least two amide groups, these two groups being located on grafts or branches.

A) According to a first variant, the silicone polymers are polyorganosiloxanes as defined above in which the amide units are located in the polymer chain.

The silicone polyamides may be more particularly polymers comprising at least one unit corresponding to the general formula I:

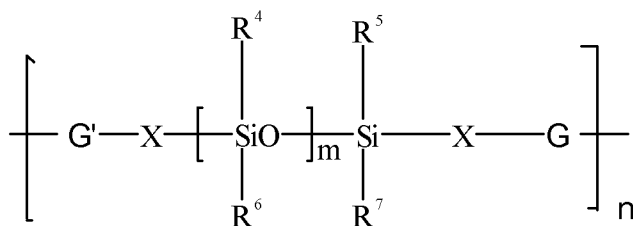

(I)

1) in which: G' represents C(O) when G represents -C(O)-NH-Y-NH-, and G' represents -NH- when G represents -NH-C(O)-Y-C(O)-,

2) R<sup>4</sup>, R<sup>5</sup>, R<sup>6</sup> and R<sup>7</sup>, which may be identical or different, represent a group chosen from:

- linear, branched or cyclic, saturated or unsaturated, C<sub>1</sub> to C<sub>40</sub> hydrocarbon-based groups, possibly containing in their chain one or more oxygen, sulfur and/or nitrogen atoms, and possibly being partially or totally substituted with fluorine atoms,
- C<sub>6</sub>-C<sub>10</sub> aryl groups, optionally substituted with one or more C<sub>1</sub>-C<sub>4</sub> alkyl groups,
- polyorganosiloxane chains possibly containing one or more oxygen, sulfur and/or nitrogen atoms,

- 3) the groups X, which may be identical or different, represent a linear or branched C<sub>1</sub> to C<sub>30</sub> alkylenediyl group, possibly containing in its chain one or more oxygen and/or nitrogen atoms;
- 4) Y is a saturated or unsaturated C<sub>1</sub> to C<sub>50</sub> linear or branched alkylene, arylene, cycloalkylene, alkylarylene or arylalkylene divalent group, which may comprise one or more oxygen, sulfur and/or nitrogen atoms, and/or may bear as substituent one of the following atoms or groups of atoms: fluorine, hydroxyl, C<sub>3</sub> to C<sub>8</sub> cycloalkyl, C<sub>1</sub> to C<sub>40</sub> alkyl, C<sub>5</sub> to C<sub>10</sub> aryl, phenyl optionally substituted with one to three C<sub>1</sub> to C<sub>3</sub> alkyl, C<sub>1</sub> to C<sub>3</sub> hydroxyalkyl and C<sub>1</sub> to C<sub>6</sub> aminoalkyl groups, or
- 5) Y represents a group corresponding to the formula:

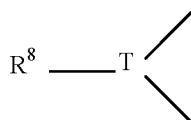

in which:

- T represents a linear or branched, saturated or unsaturated, C<sub>3</sub> to C<sub>24</sub> trivalent or tetravalent hydrocarbon-based group optionally substituted with a polyorganosiloxane chain, and possibly containing one or more atoms chosen from O, N and S, or T represents a trivalent atom chosen from N, P and Al, and
- R<sup>8</sup> represents a linear or branched C<sub>1</sub>-C<sub>50</sub> alkyl group or a polyorganosiloxane chain, possibly comprising one or more ester, amide, urethane, thiocarbamate, urea, thiourea and/or sulfonamide groups, which may possibly be linked to another chain of the polymer;

- 6) n is an integer ranging from 2 to 500 and preferably from 2 to 200, and m is an integer ranging from 1 to 1000, preferably from 1 to 700 and better still from 6 to 200.

According to the invention, 80% of the groups R<sup>4</sup>, R<sup>5</sup>, R<sup>6</sup> and R<sup>7</sup> of the polymer are preferably chosen from methyl, ethyl, phenyl and 3,3,3-trifluoropropyl groups. According to another embodiment, 80% of the groups R<sup>4</sup>, R<sup>5</sup>, R<sup>6</sup> and R<sup>7</sup> of the polymer are methyl groups.

According to the invention, Y can represent various divalent groups, furthermore optionally comprising one or two free valencies to establish bonds with other moieties of the polymer or copolymer. Preferably, Y represents a group chosen from:

- a) linear C<sub>1</sub> to C<sub>20</sub> and preferably C<sub>1</sub> to C<sub>10</sub> alkylene groups,
- b) branched C<sub>30</sub> to C<sub>56</sub> alkylene groups possibly comprising rings and unconjugated unsaturations,
- c) C<sub>5</sub>-C<sub>6</sub> cycloalkylene groups,
- d) phenylene groups optionally substituted with one or more C<sub>1</sub> to C<sub>40</sub> alkyl groups,
- e) C<sub>1</sub> to C<sub>20</sub> alkylene groups comprising from 1 to 5 amide groups,
- f) C<sub>1</sub> to C<sub>20</sub> alkylene groups comprising one or more substituents chosen from hydroxyl, C<sub>3</sub> to C<sub>8</sub> cycloalkane, C<sub>1</sub> to C<sub>3</sub> hydroxyalkyl and C<sub>1</sub> to C<sub>6</sub> alkylamine groups,
- g) polyorganosiloxane chains of formula:

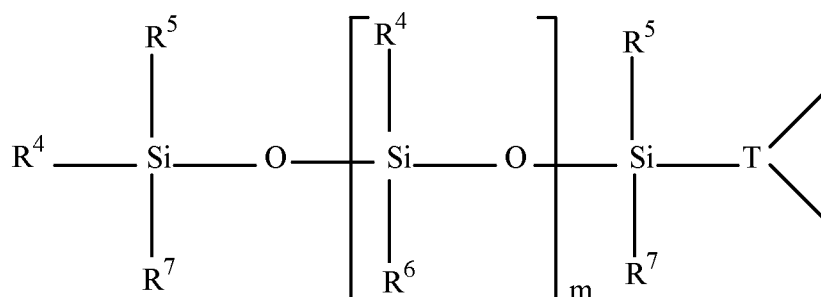

or

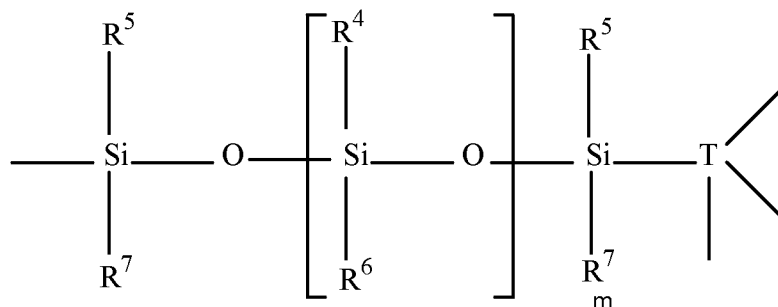

in which R<sup>4</sup>, R<sup>5</sup>, R<sup>6</sup>, R<sup>7</sup>, T and m are as defined above.

B) According to the second variant, the silicone polyamides may be polymers comprising at least one unit corresponding to formula (II):



These copolymers may be block polymers or grafted polymers.

In this first embodiment of the invention, the silicone polymer may also consist of a grafted copolymer. Thus, the polyamide containing silicone units may be grafted and optionally crosslinked with silicone chains containing amide groups. Such polymers may be synthesized with trifunctional amines.

According to one advantageous embodiment of the invention, the groups capable of establishing hydrogen interactions are amide groups of formulae -C(O)NH- and -HN-C(O)-. In this case, the structuring agent may be a polymer comprising at least one unit of formula (III) or (IV):

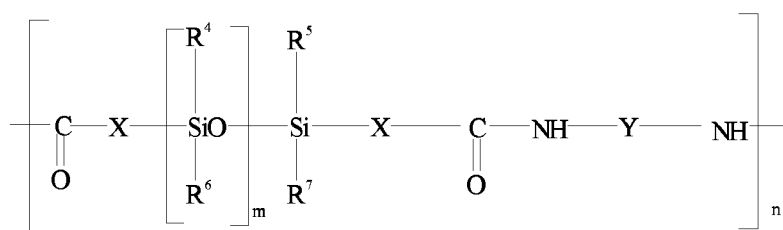

(III)

or

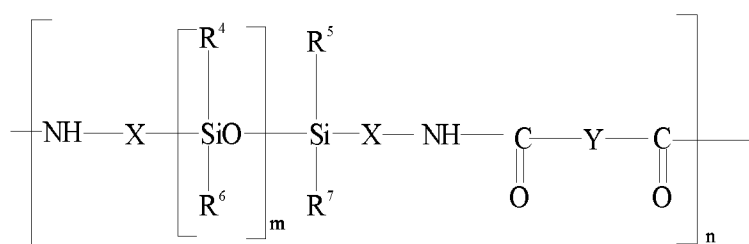

(IV)

in which R<sup>4</sup>, R<sup>5</sup>, R<sup>6</sup>, R<sup>7</sup>, X, Y, m and n are as defined above.

In these polyamides of formula (III) or (IV), m is in the range from 1 to 700, in particular from 15 to 500 and especially from 50 to 200, and n is in particular in the range from 1 to 500, preferably from 1 to 100 and better still from 4 to 25,

- X is preferably a linear or branched alkylene chain containing from 1 to 30 carbon atoms, in particular 1 to 20 carbon atoms, especially from 5 to 15 carbon atoms and more particularly 10 carbon atoms, and

- Y is preferably an alkylene chain that is linear or branched or that possibly comprises rings and/or unsaturations, containing from 1 to 40 carbon atoms, in particular from 1 to 20 carbon atoms and better still from 2 to 6 carbon atoms, in particular 6 carbon atoms.

In formulae (III) and (IV), the alkylene group representing X or Y can optionally contain in its alkylene portion at least one of the following members:

- 1) 1 to 5 amide, urea, urethane or carbamate groups,
- 2) a C<sub>5</sub> or C<sub>6</sub> cycloalkyl group, and
- 3) a phenylene group optionally substituted with 1 to 3 identical or different C<sub>1</sub> to C<sub>3</sub> alkyl groups.

In formulae (III) and (IV), the alkylene groups may also be substituted with at least one member chosen from the group consisting of:

- a hydroxyl group,
- a C<sub>3</sub> to C<sub>8</sub> cycloalkyl group,
- one to three C<sub>1</sub> to C<sub>40</sub> alkyl groups,
- a phenyl group optionally substituted with one to three C<sub>1</sub> to C<sub>3</sub> alkyl groups,
- a C<sub>1</sub> to C<sub>3</sub> hydroxyalkyl group, and
- a C<sub>1</sub> to C<sub>6</sub> aminoalkyl group.

In these formulae (III) and (IV), Y may also represent:

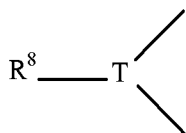

in which R<sup>8</sup> represents a polyorganosiloxane chain and T represents a group of formula:

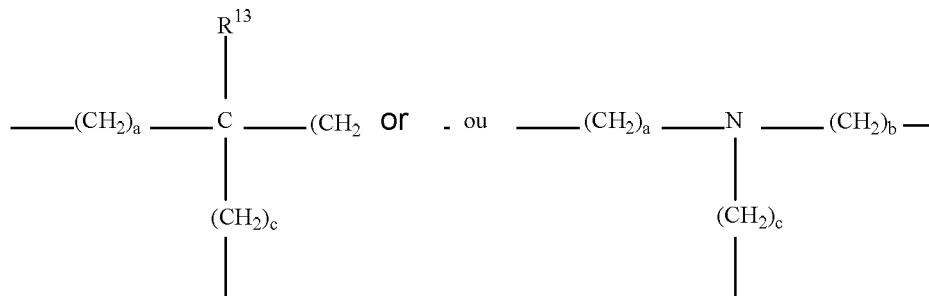

in which a, b and c are, independently, integers ranging from 1 to 10, and R<sup>13</sup> is a hydrogen atom or a group such as those defined for R<sup>4</sup>, R<sup>5</sup>, R<sup>6</sup> and R<sup>7</sup>.

In formulae (III) and (IV), R<sup>4</sup>, R<sup>5</sup>, R<sup>6</sup> and R<sup>7</sup> preferably represent, independently, a linear or branched C<sub>1</sub> to C<sub>40</sub> alkyl group, preferably a CH<sub>3</sub>, C<sub>2</sub>H<sub>5</sub>, n-C<sub>3</sub>H<sub>7</sub> or isopropyl group, a polyorganosiloxane chain or a phenyl group optionally substituted with one to three methyl or ethyl groups.

As has been seen previously, the polymer may comprise identical or different units of formula (III) or (IV).

Thus, the polymer may be a polyamide containing several units of formula (III) or (IV) of different lengths, i.e. a polyamide corresponding to formula (V):

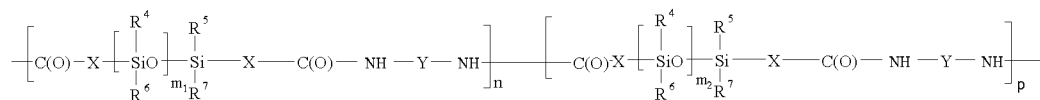

(V)

in which X, Y, n and R<sup>4</sup> to R<sup>7</sup> have the meanings given above, m<sub>1</sub> and m<sub>2</sub>, which are different, are chosen in the range from 1 to 1000, and p is an integer ranging from 2 to 300.

In this formula, the units may be structured to form either a block copolymer, or a random copolymer or an alternating copolymer. In this copolymer, the units may be not only of different lengths, but also of different chemical structures, for example containing different groups Y. In this case, the polymer may correspond to formula VI:

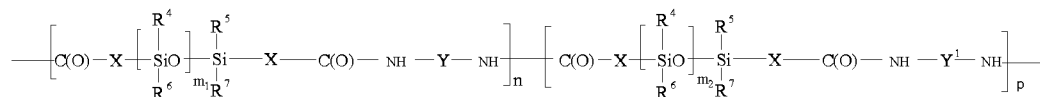

(VI)

in which R<sup>4</sup> to R<sup>7</sup>, X, Y, m<sub>1</sub>, m<sub>2</sub>, n and p have the meanings given above and Y<sup>1</sup> is different from Y but chosen from the groups defined for Y. As previously, the various units may be structured to form either a block copolymer, or a random copolymer or an alternating copolymer.

In this first embodiment of the invention, the structuring agent may also consist of a grafted copolymer. Thus, the polyamide containing silicone units may be grafted and optionally crosslinked with silicone chains containing amide groups. Such polymers may be synthesized with trifunctional amines.

In this case, the polymer may comprise at least one unit of formula (VII):

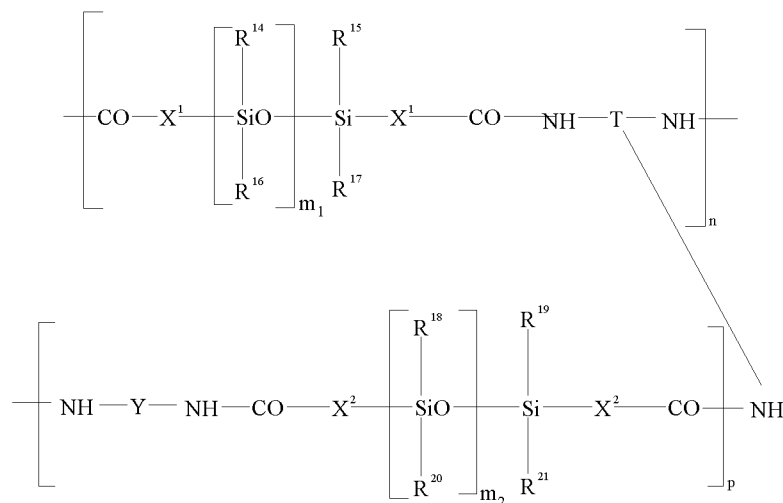

(VII)

in which X<sup>1</sup> and X<sup>2</sup>, which are identical or different, have the meaning given for X in formula (I), n is as defined in formula (I), Y and T are as defined in formula (I), R<sup>14</sup> to R<sup>21</sup> are groups chosen from the same group as R<sup>4</sup> to R<sup>7</sup>, m<sub>1</sub> and m<sub>2</sub> are numbers in the range from 1 to 1000, and p is an integer ranging from 2 to 500.

In formula (VII), it is preferred that:

- p is in the range from 1 to 25 and better still from 1 to 7,
- R<sup>14</sup> to R<sup>21</sup> are methyl groups,
- T corresponds to one of the following formulae:

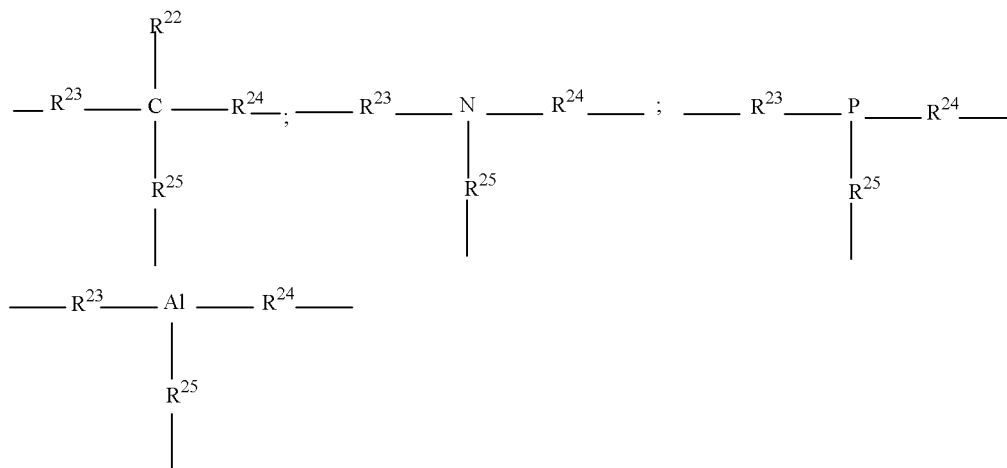

in which R<sup>22</sup> is a hydrogen atom or a group chosen from the groups defined for R<sup>4</sup> to R<sup>7</sup>, and R<sup>23</sup>, R<sup>24</sup> and R<sup>25</sup> are, independently, linear or branched alkylene groups, and more preferably correspond to the formula:

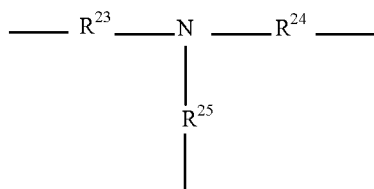

- in particular with  $R^{23}$ ,  $R^{24}$  and  $R^{25}$  representing  $-\text{CH}_2-\text{CH}_2-$ ,
- $m_1$  and  $m_2$  are in the range from 15 to 500 and better still from 15 to 45,
  - $X^1$  and  $X^2$  represent  $-(\text{CH}_2)_{10}-$ , and
  - $Y$  represents  $-\text{CH}_2-$ .

These polyamides containing a grafted silicone unit of formula (VII) may be copolymerized with polyamide-silicones of formula (II) to form block copolymers, alternating copolymers or random copolymers. The weight percentage of grafted silicone units (VII) in the copolymer may range from 0.5% to 30% by weight.

According to the invention, as has been seen previously, the siloxane units may be in the main chain or backbone of the polymer, but they may also be present in grafted or pendent chains. In the main chain, the siloxane units may be in the form of segments as described above. In the pendent or grafted chains, the siloxane units may appear individually or in segments.

According to one embodiment variant of the invention, a copolymer of silicone polyamide and of hydrocarbon-based polyamide, or a copolymer comprising units of formula (III) or (IV) and hydrocarbon-based polyamide units, may be used. In this case, the polyamide-silicone units may be located at the ends of the hydrocarbon-based polyamide.

According to one preferred embodiment, the silicone polyamide comprises units of formula III, preferably in which the groups  $R_4$ ,  $R_5$ ,  $R_6$  and  $R_7$  represent methyl groups, one from among  $X$  and  $Y$  represents an alkylene group of 6 carbon atoms and the other represents an alkylene group of 11 carbon atoms,  $n$  representing the degree of polymerization DP of the polymer.

Examples of such silicone polyamides that may be mentioned include the compounds sold by the company Dow Corning under the name DC 2-8179 (DP 100) and DC 2-8178 (DP 15), the INCI name of which is Nylon-611/dimethicone copolymers.

Advantageously, the silicone polyamides are compounds having the INCI name Nylon-611/dimethicone copolymers.

Advantageously, the composition according to the invention comprises at least one polydimethylsiloxane block polymer of general formula (I) with an index  $m$  of about 100. The index "m" corresponds to the degree of polymerization of the silicone part of the polymer.

More preferably, the composition according to the invention comprises at least one polymer comprising at least one unit of formula (III) in which  $m$  ranges from 50 to 200, in particular from 75 to 150 and is more particularly about 100.

Preferably also, R<sup>4</sup>, R<sup>5</sup>, R<sup>6</sup> and R<sup>7</sup> independently represent, in formula (III), a linear or branched C<sub>1</sub>-C<sub>40</sub> alkyl group, preferably a CH<sub>3</sub>, C<sub>2</sub>H<sub>5</sub>, n-C<sub>3</sub>H<sub>7</sub> or isopropyl group.

As examples of polymers that may be used, mention may be made of one of the silicone polyamides obtained in accordance with Examples 1 to 3 of document US-A-5 981 680.

Preferably, the nylon-611/dimethicone copolymer sold under the reference DC 2-8179 by Dow Corning is used as silicone polyamide.

The silicone polyamide may be present in the composition in a total content ranging from 0.5% to 45% by weight relative to the total weight of the composition, preferably ranging from 1% to 30% by weight and better still ranging from 2% to 20% by weight relative to the total weight of said composition.

#### Silicone resin

Examples of these silicone resins that may be mentioned include:

- siloxysilicates, which may be trimethylsiloxysilicates of formula  $[(\text{CH}_3)_3\text{SiO}]_x(\text{SiO}_{4/2})_y$  (units MQ) in which x and y are integers ranging from 50 to 80,
- polysilsesquioxanes of formula  $(\text{CH}_3\text{SiO}_{3/2})_x$  (units T) in which x is greater than 100 and at least one of the methyl radicals of which may be substituted with a group R as defined above,
- polymethylsilsesquioxanes, which are polysilsesquioxanes in which none of the methyl radicals is substituted with another group. Such polymethylsilsesquioxanes are described in document US 5 246 694.

As examples of commercially available polymethylsilsesquioxane resins, mention may be made of those sold:

- by the company Wacker under the reference Resin MK, such as Belsil PMS MK: polymer comprising  $\text{CH}_3\text{SiO}_{3/2}$  repeating units (units T), which may also comprise up to 1% by weight of  $(\text{CH}_3)_2\text{SiO}_{2/2}$  units (units D) and having an average molecular weight of about 10 000 g/mol, or
- by the company Shin-Etsu under the reference KR-220L, which are composed of units T of formula  $\text{CH}_3\text{SiO}_{3/2}$  and contain Si-OH (silanol) end groups, under the reference KR-242A, which comprise 98% of units T and 2% of dimethyl units D and contain Si-OH end groups, or under

the reference KR-251, comprising 88% of units T and 12% of dimethyl units D and contain Si-OH end groups.

Siloxysilicate resins that may be mentioned include trimethyl siloxysilicate resins (TMS) optionally in the form of powders. Such resins are sold under the reference SR1000 by the company Momentive Performance Materials or under the reference TMS 803 by the company Wacker. Mention may also be made of trimethyl siloxysilicate resins sold in a solvent such as cyclomethicone, sold under the name KF-7312J by the company Shin-Etsu or DC 749 and DC 593 by the company Dow Corning.

Advantageously, the silicone resin, for instance the trimethyl siloxysilicate resin, is present in a content ranging from 0.5% to 30%, or better still from 1% to 25% or even better still from 5% to 25% relative to the total weight of the composition.

Preferably, nylon-611/dimethicone is used as silicone polyamide and a trimethyl siloxysilicate resin is used as silicone resin.

According to another embodiment, the silicone resins are, propylphenylsilsesquioxane resins.

Silsesquioxane resins are a specific form of film forming silicone resins. Silicone resins are crosslinked organopolysiloxanes which are solid at room temperature and generally soluble in organic solvents. When they are soluble in volatile solvents, silicone resins are capable of forming a film once the solvent has evaporated. Furthermore, if the solvent dissolving the silicone resin is absorbed on the substrate onto which it is applied, the silicone resin which remains on the substrate may also form a film.

The compositions of the present invention comprise propylphenylsilsesquioxane resins, which have been disclosed in patent publications WO2005/090444, published on September 29, 2005; US20040180011, published on September 16, 2004; and US20040156806, published on August 12, 2004.

The propylphenylsilsesquioxane resin comprises at least about 70 mole % of propyl siloxy units ( $C_3H_7SiO_{3/2}$ ), based on the total mole % siloxy units of the resin, and at most about 30 mole % of phenyl siloxy units ( $C_6H_5SiO_{3/2}$ ), based on the total mole % siloxy units of the resin.

The mole % of propyl siloxy units to phenyl siloxy units can be adjusted depending on an intended application. As such, it is possible to have propylphenylsilsesquioxane resins having a mole % propyl siloxy units:phenyl siloxy units ranging from about 70:30 to about 100:0, such as 70:30; 80:20; 90:10; and 100:0; and subranges therebetween. When the mole % of the propyl siloxy units is about 100

mole %, the propylphenylsilsesquioxane resin is referred to as a propylsilsesquioxane resin.

A suitable example of a propylphenylsilsesquioxane resin for use in cosmetic compositions of the present invention includes, but is not limited to, a propylsilsesquioxane resin commercially available from Dow-Corning under the tradename DC 670 Fluid.

The propylphenylsilsesquioxane film forming resin may be present in an amount ranging from about 0.5% to about 50% by weight, such as from about 1% to about 40% by weight, such as from about 2% to about 30% by weight, such as from about 3% to about 20% by weight, and such as from about 4% to about 10% by weight, all weights based on the weight of the composition as a whole.

#### Silicone acrylate copolymers

The gel composition of the present invention may contain silicone acrylate copolymers.

Silicone acrylate copolymers are another specific form of film forming silicone resins. They are available as silicone acrylate copolymers with a (meth)acrylate backbone grafted with a silicone chain or as a silicone backbone grafted with a (meth)acrylate, or as a silicone acrylate dendrimer.

Silicone acrylate dendrimers, such as those described and claimed in US Patent No. 6,280,748, the entire contents of which is hereby incorporated by reference, are preferred for use in the composition of the present invention. The silicone acrylate dendrimer is comprised of a vinyl polymer having a carbosiloxane dendrimer structure in its side molecular chain. It is characterized by a vinyl-type polymer which has in its side molecular chain a carbosiloxane dendrimer structure. The term "carbosiloxane dendrimer structure" is a structure with high-molecular-weight groups branched with high regularity in a radial direction from a single core.

The vinyl polymer backbone is formed from a vinyl-type monomer which contains a radical polymerizable vinyl group. In its broadest definition, there are no particular limitations with regards to the type of such a monomer. A particularly preferred vinyl polymer is a (meth)acrylate.

The number-average molecular weight of the silicone acrylate dendrimers for use in the composition of the present invention ranges from about 3,000 to about 2,000,000, such as from about 5,000 to about 800,000.

Particularly preferred silicone acrylate dendrimers for use in the composition of the present invention are available from Dow Corning as FA-4001 CM silicone acrylate, a 30% solution in cyclomethicone, and as FA-4002 ID silicone acrylate, a 40% solution in isododecane, under the INCI name of Acrylates/Polytrimethylsiloxymethacrylate Copolymer.

The silicone acrylate copolymer may be present in the composition of the invention in an amount ranging from about 0.5% to about 20% by weight, such as from about 0.7% to about 15% by weight, such as from about 1% to about 10% by weight, all weights based on the weight of the composition as a whole.

### **Pulverulent phase**

A composition of the invention may contain a pulverulent phase materials besides the microcapsules defined above.

A composition according to the invention may comprise at least 1% by weight and more particularly at least 5% by weight of pulverulent phase relative to the total weight of the said composition.

More particularly, a composition according to the invention may comprise at least 15% by weight and more particularly at least 20% by weight of pulverulent phase relative to the total weight of the said composition.

For the purposes of the present invention, this pulverulent phase may comprise, besides the microcapsules required according to the invention, at least one non-entrapped particulate material chosen from fillers; pigments; nacres; particles with a metallic tint; and mixtures thereof.

Thus, a composition according to the invention advantageously may comprise from 1% to 70% by weight, preferably from 5% to 60% by weight and better still from 10% to 50% by weight of pulverulent phase relative to the total weight of the said composition.

Thus, a composition according to the invention advantageously may comprise from 15% to 70% by weight, preferably from 20% to 60% by weight and better still from 25% to 50% by weight of pulverulent phase relative to the total weight of the said composition.

#### **a) non entrapped Filler**

For the purposes of the present invention, the term "fillers" should be understood as meaning colourless or white solid particles of any form, which are in an insoluble and dispersed form in the medium of the composition.

These fillers, of mineral or organic, natural or synthetic nature, give the composition containing them softness and give the makeup result a matt effect and uniformity.

A composition according to the invention may comprise from 0.5% to 50% by weight and preferably from 1% to 30% by weight of fillers relative to the total weight of the said composition.

This amount of fillers does not include the amount of hollow particles required in parallel according to the invention.

Among the mineral fillers that may be used in the compositions according to the invention, mention may be made of natural or synthetic mica, talc, kaolin, natural or synthetic sericite, silica, hydroxyapatite, boron nitride, calcium carbonate, hollow silica microspheres (Silica beads from Maprecos), glass or ceramic microcapsules; composites of silica and titanium dioxide, such as the TSG series sold by Nippon Sheet Glass, and mixtures thereof.

Among the organic fillers that may be used in the compositions according to the invention, mention may be made of polyamide powders (Nylon® Orgasol from Atochem), poly-β-alanine powder and polyethylene powder, polytetrafluoroethylene (Teflon®) powder, lauroyllysine, tetrafluoroethylene polymer powders, spherical powders of crosslinked elastomeric organopolysiloxane, described especially in document JP-A-02-243612, such as those sold under the name Trefil Powder E 2-506C or DC9506 or DC9701 by the company Dow Corning, silicone resins, which are products of hydrolysis and polycondensation of siloxane mixtures of formulae  $(R)_3SiOHCH_3$  and  $Si(OCH_3)_4$ , R representing an alkyl group containing from 1 to 6 carbon atoms (for example KSP100 from Shin-Etsu), silicone resin microbeads (for example Tospearl® from Toshiba), Polypore® L200 (Chemdal Corporation), polyurethane powders, in particular crosslinked polyurethane powders comprising a copolymer, the said copolymer comprising trimethylol hexyl lactone, for instance the polymer of hexamethylene diisocyanate/trimethylol hexyl lactone, sold under the name Plastic powder D-400® or Plastic Powder D-800® by the company Toshiki, and mixtures thereof.

Among the other organic fillers that may be used in the compositions according to the invention, mention may be made of starch-based or cellulose-based

powders. Examples of such fillers that may be mentioned include the Dry Flo products sold by Akzo Nobel and the Cellubeads products sold by the company Daito Kasei.

Advantageously, the fillers in accordance with the invention are mineral fillers, preferably chosen from mica, sericite, kaolin, talc and silica, and mixtures thereof.

c) non entrapped particulate materials for colouring purposes.

These additional colouring particulate materials may be present in a proportion of from 0 to 40% by weight, preferably from 1% to 30% by weight or even 5% to 30% by weight relative to the total weight of the composition containing them.

They may especially be pigments, nacles and/or particles with metallic tint products, these materials possibly being surface-treated.

The term "pigments" should be understood as meaning white or coloured, mineral or organic particles that are insoluble in an aqueous solution, which are intended to colour and/or opacify the composition containing them.

A composition according to the invention may comprise from 0.01% to 40% by weight, preferably from 0.1% to 20% by weight and better still from 1% to 15% by weight of pigments relative to the total weight of said composition.

The pigments may be white or coloured, and mineral and/or organic.

As mineral pigments that may be used in the invention, mention may be made of titanium oxide, titanium dioxide, zirconium oxide, zirconium dioxide, cerium oxide or cerium dioxide and also zinc oxide, iron oxide or chromium oxide, ferric blue, manganese violet, ultramarine blue and chromium hydrate, and mixtures thereof.

According to a specific embodiment, the composition of the invention contain at least non-entrapped inorganic pigments chosen from titanium dioxide, zinc oxide, cerium oxide, and/or fillers chosen from bisulth oxychloride or boron nitride, in order to improve the white color of the composition.

According to a specific embodiment, the compositions of the invention contain at least non-entrapped  $\text{TiO}_2$ .

It may also be a pigment having a structure that may be, for example, of sericite/brown iron oxide/titanium dioxide/silica type. Such a pigment is sold, for example, under the reference Coverleaf NS or JS by the company Chemicals and Catalysts, and has a contrast ratio in the region of 30.

They may also be pigments having a structure that may be, for example, of silica microsphere type containing iron oxide. An example of a pigment having this structure is the product sold by the company Miyoshi under the reference PC Ball PC-

LL-100 P, this pigment being constituted of silica microspheres containing yellow iron oxide.

Advantageously, the pigments in accordance with the invention are iron oxides and/or titanium dioxides.

The term "nacres" should be understood as meaning iridescent or non-iridescent coloured particles of any shape, especially produced by certain molluscs in their shell or alternatively synthesized, which have a colour effect via optical interference.

A composition of the invention may comprise from 1% to 80% by weight, preferably from 5% to 60% by weight and better still from 10% to 40% by weight of nacres relative to the total weight of said composition.

The nacres may be chosen from nacreous pigments such as titanium mica coated with an iron oxide, titanium mica coated with bismuth oxychloride, titanium mica coated with chromium oxide, titanium mica coated with an organic dye and also nacreous pigments based on bismuth oxychloride. They may also be mica particles at the surface of which are superposed at least two successive layers of metal oxides and/or of organic dyestuffs.

Examples of nacres that may also be mentioned include natural mica coated with titanium oxide, with iron oxide, with natural pigment or with bismuth oxychloride.

Among the nacres available on the market, mention may be made of the nacres Timica, Flamenco and Duochrome (based on mica) sold by the company Engelhard, the Timiron nacres sold by the company Merck, the Prestige mica-based nacres, sold by the company Eckart, and the Sunshine synthetic mica-based nacres, sold by the company Sun Chemical.

The nacres may more particularly have a yellow, pink, red, bronze, orange, brown, gold and/or coppery colour or tint.

As illustrations of nacres that may be used in the context of the present invention, mention may be made of gold-coloured nacres sold especially by the company Engelhard under the name Brilliant gold 212G (Timica), Gold 222C (Cloisonne), Sparkle gold (Timica), Gold 4504 (Chromalite) and Monarch gold 233X (Cloisonne); the bronze nacres sold especially by the company Merck under the names Bronze fine (17384) (Colorona) and Bronze (17353) (Colorona) and by the company Engelhard under the name Super bronze (Cloisonne); the orange nacres sold especially by the company Engelhard under the names Orange 363C (Cloisonne) and Orange

MCR 101 (Cosmica) and by the company Merck under the names Passion orange (Colorona) and Matte orange (17449) (Microna); the brown-tinted nacres sold especially by the company Engelhard under the names Nu antique copper 340XB (Cloisonne) and Brown CL4509 (Chromalite); the nacres with a copper tint sold especially by the company Engelhard under the name Copper 340A (Timica); the nacres with a red tint sold especially by the company Merck under the name Sienna fine (17386) (Colorona); the nacres with a yellow tint sold especially by the company Engelhard under the name Yellow (4502) (Chromalite); the red-tinted nacres with a golden tint sold especially by the company Engelhard under the name Sunstone G012 (Gemtone); the pink nacres sold especially by the company Engelhard under the name Tan opale G005 (Gemtone); the black nacres with a golden tint sold especially by the company Engelhard under the name Nu antique bronze 240 AB (Timica); the blue nacres sold especially by the company Merck under the name Matte blue (17433) (Microna); the white nacres with a silvery tint sold especially by the company Merck under the name Xirona Silver; and the golden-green pinkish-orange nacres sold especially by the company Merck under the name Indian summer (Xirona), and mixtures thereof.

Advantageously, the nacres in accordance with the invention are micas coated with titanium dioxide or with iron oxide, and also bismuth oxychloride.

The term "particles with a metallic tint", within the meaning of the present invention, denotes particles whose nature, size, structure and surface state allow them to reflect the incident light, especially in a non-iridescent manner.

A composition according to the invention may comprise from 1% to 50% by weight and preferably from 1% to 20% by weight of particles with a metallic tint relative to the total weight of said composition.

Particles with a substantially flat outer surface are also suitable, since they can, if their size, structure and surface state allow it, more easily give rise to a strong specular reflection, which may then be termed a mirror effect.

The particles with a metallic tint that may be used in the invention may, for example, reflect light in all the components of the visible region without significantly absorbing one or more wavelengths. The spectral reflectance of these particles may, for example, be greater than 70% and better still at least 80%, or even 90% or 95%, in the range 400-700 nm.

These particles generally have a thickness of less than or equal to 1  $\mu\text{m}$ , especially less than or equal to 0.7  $\mu\text{m}$  and in particular less than or equal to 0.5  $\mu\text{m}$ .

The particles with a metallic tint that may be used in the invention are in particular chosen from:

- particles of at least one metal and/or of at least one metal derivative,
- particles comprising a monomaterial or multimaterial organic or mineral substrate, at least partially coated with at least one layer with a metallic tint comprising at least one metal and/or at least one metal derivative, and mixtures of said particles.

Among the metals that may be present in said particles, mention may be made, for example, of Ag, Au, Cu, Al, Ni, Sn, Mg, Cr, Mo, Ti, Zr, Pt, Va, Rb, W, Zn, Ge, Te and Se, and mixtures or alloys thereof. Ag, Au, Cu, Al, Zn, Ni, Mo and Cr and mixtures or alloys thereof (for example bronzes and brasses) are preferred metals.

The term "metal derivatives" is intended to denote compounds derived from metals, especially oxides, fluorides, chlorides and sulfides.

Among the metal derivatives that may be present in said particles, mention may be made especially of metal oxides, for instance titanium oxide, especially  $\text{TiO}_2$ , iron oxide, especially  $\text{Fe}_2\text{O}_3$ , tin oxide, chromium oxide, barium sulfate and the following compounds:  $\text{MgF}_2$ ,  $\text{CrF}_3$ ,  $\text{ZnS}$ ,  $\text{ZnSe}$ ,  $\text{SiO}_2$ ,  $\text{Al}_2\text{O}_3$ ,  $\text{MgO}$ ,  $\text{Y}_2\text{O}_3$ ,  $\text{SeO}_3$ ,  $\text{SiO}$ ,  $\text{HfO}_2$ ,  $\text{ZrO}_2$ ,  $\text{CeO}_2$ ,  $\text{Nb}_2\text{O}_5$ ,  $\text{Ta}_2\text{O}_5$ ,  $\text{MoS}_2$ , and mixtures or alloys thereof.

Illustrations of these particles that may be mentioned include aluminum particles, such as those sold under the names Starbrite 1200 EAC<sup>®</sup> by the company Siberline and Metalure<sup>®</sup> by the company Eckart.

Mention may also be made of metal powders of copper or of alloy mixtures such as the references 2844 sold by the company Radium Bronze, metallic pigments, for instance aluminum or bronze, such as those sold under the names Rotosafe 700 from the company Eckart, silica-coated aluminum particles sold under the name Visionaire Bright Silver from the company Eckart, and metal alloy particles, for instance the silica-coated bronze (alloy of copper and zinc) powders sold under the name Visionaire Bright Natural Gold from the company Eckart.

As illustrations of particles of this second type, mention may be made more particularly of:

Glass particles coated with a metallic layer, especially those described in documents JP-A-09188830, JP-A-10158450, JP-A-10158541, JP-A-07258460 and JP-A-05017710.

As illustrations of these particles comprising a glass substrate, mention may be made of those coated, respectively, with silver, gold or titanium, in the form of

platelets, sold by the company Nippon Sheet Glass under the name Microglass Metashine. Particles with a silver-coated glass substrate, in the form of platelets, are sold under the name Microglass Metashine REFSX 2025 PS by the company Toyal. Particles with a glass substrate coated with nickel/chromium/molybdenum alloy are sold under the name Crystal Star GF 550 and GF 2525 by this same company. Those coated either with brown iron oxide or with titanium oxide, tin oxide or a mixture thereof, for instance those sold under the name Reflecks by the company Engelhard or those sold under the name Metashine MC 2080GP by the company Nippon Sheet Glass.

These metal-coated glass particles may be coated with silica, for instance those sold under the name Metashine series PSS1 or GPS1 by the company Nippon Sheet Glass.

Particles comprising a spherical glass substrate optionally coated with a metal, especially those sold under the name Prizmalite Microsphere by the company Prizmalite Industries.

Pigments of the Metashine 1080R range sold by the company Nippon Sheet Glass Co. Ltd are also suitable for the invention. These pigments, more particularly described in patent application JP 2001-11340, are C-Glass glass flakes comprising 65% to 72% SiO<sub>2</sub>, coated with a layer of titanium oxide of rutile type (TiO<sub>2</sub>). These glass flakes have a mean thickness of 1 micron and a mean size of 80 microns, i.e. a mean size/mean thickness ratio of 80. They have blue, green or yellow tints or a silver shade depending on the thickness of the TiO<sub>2</sub> layer.

Particles comprising a silver-coated borosilicate substrate, are also known as "white nacres".

Particles comprising a metal substrate such as aluminum, copper or bronze, in the form of platelets, are sold under the trade name Starbrite by the company Silberline and under the name Visionaire by the company Eckart.

Particles comprising a synthetic mica substrate coated with titanium dioxide, and for example particles with a size of between 80 and 100 μm, comprising a synthetic mica (fluorophlogopite) substrate coated with titanium dioxide representing 12% of the total weight of the particle, sold under the name Prominence by the company Nihon Koken.

The particles with a metallic tint may also be chosen from particles formed from a stack of at least two layers with different refractive indices. These layers may be of polymeric or metallic nature and may especially include at least one polymer layer.

Thus, the particles with a metallic effect may be particles derived from a multilayer polymer film.

The choice of materials intended to constitute the various layers of the multilayer structure is obviously made so as to give the particles thus formed the desired metallic effect.

Such particles are especially described in WO 99/36477, US 6 299 979 and US 6 387 498 and more particularly identified below in the goniochromatic section.

Advantageously, the particles with a metallic tint in accordance with the invention are particles with a spherical or non-spherical glass substrate, and also particles with a metallic substrate.

According to a specific embodiment, a composition according to the invention contains at least reflective particles in particular selected the nacres, particles with a metallic tint, and bismuth oxichloride and their mixtures.

As illustrations of particles of this second type, mention may be made more particularly of:

- Particles comprising a synthetic mica substrate coated with titanium dioxide coated or particles comprising a spherical glass substrate optionally coated with either with brown iron oxide or with titanium oxide, tin oxide or a mixture thereof, for instance those sold under the name Reflecks by the company Engelhard or those sold under the name Metashine MC 2080GP by the company Nippon Sheet Glass. Such particles are detailed in JP-A-09188830, JP-A-10158450, JP-A-10158541, JP-A-07258460 and JP-A-05017710.

- Particles with metallic effect comprising mineral substrate coated with a metal. It may be a particles having a silver-coated borosilicate substrate, are also known as "white nacres

- Particles comprising a spherical glass substrate coated with silver, especially those sold under the name MICROGLASS METASHINE REFSX 2025 PS by TOYAL. Particles comprising a spherical glass substrate coated with nickel/chrome/molybdene alloy especially those sold under the name CRYSTAL STAR GF 550, GF 2525 by the same company.

- Particles having metallic effect and having on surface a metallic compound optionally coated particles sold under the names METASHINE<sup>®</sup> LE 2040 PS, METASHINE<sup>®</sup> 5 MC5090 PS or METASHINE<sup>®</sup> MC280GP (2523) by the company NIPPON SHEET GLASS, SPHERICAL SILVER POWDER<sup>®</sup> DC 100, SILVER FLAKE<sup>®</sup> JV 6 or GOLD POWDER<sup>®</sup> A1570 by the company ENGELHARD, STARLIGHT

REFLECTIONS FXM<sup>®</sup> by the company ENERGY STRATEGY ASSOCIATES INC, BRIGHT SILVER<sup>®</sup> 1 E 0.008X0.008 by the company MEADOWBROOK INVENTIONS, ULTRAMIN<sup>®</sup> (ALUMINUM POWDRE FINE LIVING), and COSMETIC METALLIC POWDER VISIONNAIRE BRIGHT SILVER SEA<sup>®</sup>, COSMETIC METALLIC POWDER VISIONNAIRE NATURAL GOLD<sup>®</sup> (60314) or COSMETIC METALLC POWDER VISIONNAIRE HONEY<sup>®</sup> 560316° by the company ECKART.

More preferably, these reflective particles are chosen in the group consisting of bismuth oxichloride particles, mica particles coated with titanium oxide, and mixtures thereof.

According to a specific embodiment, a composition of the invention contains at least bismuth oxichloride (CI 77163).

Advantageously, a composition of the invention may also contains at least nacres comprising a silver-coated borosilicate substrate, are also known as "white nacres". Such particles are sold by the firm MERCK under the tradename Xirona Silver.

The composition may comprise reflective particles pre-dispersed in one oil selected from mineral, vegetable oils and ester oils.

According to a preferred embodiment, these reflective particles are present in the compositions of the invention under a pre-dispersed form in at least one oil selected in the group consisting of

- Mineral oils
- Vegetable oils like sweet almond oil, wheat germ oil, jojoba oil, apricot oil, soybean oil, canola oil, castor oil ;
- Esters such as octyl dodecanol, octyldodecyl neopentanoate, caprylic/capric triglycerides, pentaerythrityl tetraisostearate, isodecyl neopentanoate, diisopropyl sebacate, C<sub>12</sub>-C<sub>15</sub> alkyl benzoate, ethylhexyl ethylhexanoate, ethylhexyl hydroxystearate,  
and mixture thereof.

More preferably, the oil is chosen in the group consisting of l'hydroxystearate d'éthyl (2) hexyle, ou l'huile de ricin, and preferably ethyl (2) hexyl hydroxystearate.

Thus, according to a specific and preferred embodiment, a composition of the invention comprises, in a physiologically acceptable medium,

- (i) at least microcapsules of the invention and
- (ii) At least reflective particles under a pre-dispersed form in at least one

oil selected in the group consisting of ethyl (2) hexyl hydroxystearate or castor oil and preferably ethyl (2) hexyl hydroxystearate.

Advantageously, the reflective particles are chosen among bismuth oxichloride particles and mica particles covered with titanium oxide, said particles being pre-dispersed ethyl (2) hexylhydroxystearate.

According to a specific embodiment, the composition of the invention comprises a pre-dispersion comprising from 68% to 72% by weight of bismuth oxichloride in 28% to 32% by weight of ethyl (2) hexylhydroxystearate d'ethyl (2) hexyle, with respect to the total weight of the pre-dispersion i.e a weight ratio bismuth oxichloride /oil(s) greater or equal to 2, and preferably ranging from 2 to 2.6.

Such a dispersion is sold by the firm MERCK under the tradename Xirona Silver.Biron<sup>®</sup> Liquid Silver.

### **Additional Moisturizers**

For a particular care application, a composition according to the invention may comprise at least one moisturizer (also known as a humectant).

The moisturizer(s) may be present in the composition in a content ranging from 0.1% to 15% by weight, especially from 0.5% to 10% by weight or even from 1% to 6% by weight, relative to the total weight of the said composition.

Moisturizers or humectants that may especially be mentioned include sorbitol, polyhydric alcohols, preferably of C<sub>2</sub>-C<sub>8</sub> and more preferably C<sub>3</sub>-C<sub>6</sub>, preferably such as glycerol, propylene glycol, 1,3-butylene glycol, pentylene glycol, hexylene glycol, dipropylene glycol, diethylene glycol and diglycerol, and mixtures thereof, glycerol and derivatives thereof, glycol ethers (especially containing from 3 to 16 carbon atoms) such as mono-, di- or tripropylene glycol (C<sub>1</sub>-C<sub>4</sub>)alkyl ethers, mono-, di- or triethylene glycol (C<sub>1</sub>-C<sub>4</sub>)alkyl ethers, urea and derivatives thereof, especially Hydrovance (2-hydroxyethylurea) sold by National Starch, lactic acids, hyaluronic acid, AHAs, BHAs, sodium pidolate, xylitol, serine, sodium lactate, ectoin and derivatives thereof, chitosan and derivatives thereof, collagen, plankton, an extract of *Imperata cylindrica* sold under the name Moist 24 by the company Sederma, acrylic acid homopolymers, for instance Lipidure-HM<sup>®</sup> from NOF Corporation, beta-glucan and in particular sodium carboxymethyl beta-glucan from Mibelle-AG-Biochemistry; a mixture of passionflower oil, apricot oil, corn oil and rice bran oil sold by Nestle under the name NutraLipids<sup>®</sup>; a C-glycoside derivative such as those described in patent application WO 02/051 828 and in particular C-β-D-xylopyranoside-2-hydroxypropane in the form of a solution

containing 30% by weight of active material in a water/propylene glycol mixture (60/40% by weight) such as the product manufactured by Chimex under the trade name Mexoryl SBB<sup>®</sup>; an oil of musk rose sold by Nestle; spheres of collagen and of chondroitin sulfate of marine origin (Atelocollagen) sold by the company Engelhard Lyon under the name Marine Filling Spheres; hyaluronic acid spheres such as those sold by the company Engelhard Lyon; arginine, argan oil, and mixtures thereof.

Preferably, use will be made of a moisturizer chosen from glycerol, urea and derivatives thereof, especially Hydrovance<sup>®</sup> sold by National Starch, a C-glycoside derivative such as those described in patent application WO 02/051 828 and in particular C- $\beta$ -D-xylopyranoside-2-hydroxypropane in the form of a solution containing 30% by weight of active material in a water/propylene glycol mixture (60/40% by weight) such as the product manufactured by Chimex under the trade name Mexoryl SBB<sup>®</sup>; argan oil, and mixtures thereof.

More preferably, glycerol will be used.

### **Sunscreen/sunblock agents**

Sunscreens are important skin-care products used to prevent photoaging and skin cancer. There are two groups of sunscreens: UVA sunscreens, which block UV radiation in the wavelength range of about 320 to 400 nm, and UVB sunscreens, which block radiation in the range of 290 to 320 nm.

The compositions in accordance with the invention comprise organic and/or inorganic UV sunscreen ingredients active in the UV-A and/or UV-B region which are hydrophilic and/or lipophilic.

In particular, the UV sunscreen ingredients according to the invention might have a solubility parameter ranging from 8.0 to 9.5. Said UV sunscreen ingredients have a good plasticizer function.

Advantageously, the UV sunscreen agent according to the invention might have a molecular weight ranging from 150 to 500 g/mol and contain hydrophobic sites and benzene nucleus or electron resonance group binding with polar sites.

The hydrophilic and/or lipophilic organic UV sunscreen ingredients are selected in particular from dibenzoylmethane derivatives; cinnamic derivatives; salicylic derivatives; benzophenone derivatives;  $\beta,\beta$ -diphenylacrylate derivatives; p-aminobenzoic acid (PABA) derivatives; and their mixtures.

Mention may be made, as examples of organic UV sunscreen ingredients, of those denoted below under their INCI names:

- para-Aminobenzoic acid derivatives:
  - PABA,
  - Ethyl PABA,
  - Ethyl Dihydroxypropyl PABA,
  - Ethylhexyl Dimethyl PABA, marketed in particular under the trademark "Escalol 507" by ISP,
  - Glyceryl PABA,
- Dibenzoylmethane Derivatives:
  - Butyl Methoxydibenzoylmethane, marketed in particular under the trademark "Parsol 1789" by Hoffmann-LaRoche,
  - Isopropyl Dibenzoylmethane,
- Salicylic Derivatives:
  - Homosalate, marketed under the trademark "Eusolex HMS" by Rona/EM Industries,
  - Ethylhexyl Salicylate, marketed under the trademark "Neo Heliopan OS" by Haarmann and Reimer,
  - Dipropyleneglycol Salicylate, marketed under the trademark "Dipsal" by Scher,
  - TEA Salicylate, marketed under the trademark "Neo Heliopan TS" by Haarmann and Reimer,
- Cinnamic Derivatives:
  - Ethylhexyl Methoxycinnamate, marketed in particular under the trademark "Parsol MCX" by Hoffmann-LaRoche,
  - Isopropyl Methoxycinnamate,
  - Isoamyl Methoxycinnamate, marketed under the trademark "Neo Heliopan E 1000" by Haarmann and Reimer,
  - Cinoxate,
  - DEA Methoxycinnamate,
  - Diisopropyl Methylcinnamate,
  - Glyceryl Ethylhexanoate Dimethoxycinnamate,
- $\beta,\beta$ -Diphenylacrylate Derivatives:
  - Octocrylene, marketed in particular under the trademark "Uvinul N539" by BASF,
  - Etocrylene, marketed in particular under the trademark "Uvinul N35" by BASF,

- Benzophenone Derivatives:
    - Benzophenone-1, marketed under the trademark "Uvinul 400" by BASF,
    - Benzophenone-2, marketed under the trademark "Uvinul D50" by BASF,
    - Benzophenone-3 or Oxybenzone, marketed under the trademark "Uvinul M40" by BASF,
    - Benzophenone-4, marketed under the trademark "Uvinul MS40" by BASF,
    - Benzophenone-5,
    - Benzophenone-6, marketed under the trademark "Helisorb 11" by Norquay,
- and their mixtures.

The preferred UV sunscreen ingredients are selected in the group consisting of cinnamic derivatives,  $\beta,\beta$  diphénylacrylates derivatives, salicylic derivatives, and their mixtures.

The preferred UV sunscreen ingredients are especially selected in the group consisting of ethylhexyl methoxycinnamate, octocrylene and ethylhexyl salicylate, and their mixtures.

Mention may be made especially of ethylhexyl methoxycinnamate sold under the tradename UVINUL MC 80<sup>®</sup> by the company BASF, of ethylhexyl salicylate sold under the tradename NEO HELIOPAN OS<sup>®</sup> by the company SYMRISE and of octocrylene sold under the tradename NEO HELIOPAN 303<sup>®</sup> by the company SYMRISE.

The composition in accordance with the invention may comprise from 0.1% to 30% by weight, for example from 0.5 to 20% by weight, for example from 1 to 15% by weight, and for example at least 1% by weight, of UV sunscreen ingredient relative to the total weight of the composition.

According to one exemplary embodiment, the composition may comprise the microcapsules and at least one UV sunscreen ingredient in a weight ratio [mineral filler/UV sunscreen ingredient] ranging from 0.20 to 10, for example from 1 to 9.5, preferably from 3 to 9.

Advantageously, the composition of the invention comprises at least one UV filter and eventually an active agent.

### **Active agents**

For application in particular for caring for or making up skin, the composition according to the invention may comprise at least one active agent chosen from:

According to one advantageous embodiment, the combination according to the invention may be combined with one or more supplementary cosmetic active agents.

These active agents may be chosen from antiwrinkle agents vitamins, in particular B3, B8, B12 and B9, moisturizers, desquamating agents, anti-ageing active agents, depigmenting agents, antioxidants, , etc.

These active agents may be present in the composition in a content ranging from 0.001% to 20% by weight, preferably from 0.01% to 10% by weight, and more preferably from 0.01% to 5% by weight, relative to the total weight of the composition.

Antiwrinkle agents: mention may be made to ascorbic acid and derivatives thereof, such as magnesium ascorbyl phosphate and ascorbyl glucoside; tocopherol and derivatives thereof, such as tocopheryl acetate; nicotinic acid and precursors thereof, such as nicotinamide; ubiquinone; glutathione and precursors thereof, such as L-2-oxothiazolidine-4-carboxylic acid; C-glycoside compounds and derivatives thereof, as described in particular hereinafter: extracts of plants, and in particular extracts of sea fennel and of olive leaf; and also plant proteins and hydrolysates thereof, such as rice or soybean protein hydrolysates; algal extracts and in particular of laminaria; bacterial extracts; sapogenins, such as diosgenin and extracts of Dioscorea plants, in particular of wild yam, containing them;  $\alpha$ -hydroxy acids;  $\beta$ -hydroxy acids, such as salicylic acid and 5-n-octanoylsalicylic acid; oligopeptides and pseudodipeptides and acyl derivatives thereof, in particular {2-[acetyl-(3-trifluoromethyl)phenyl)amino]-3-methylbutyrylamino}acetic acid and the lipopeptides sold by the company Sederma under the trade names Matrixyl 500 and Matrixyl 3000; lycopene; manganese salts and magnesium salts, in particular manganese and magnesium gluconates; and mixtures thereof;

- Desquamating agents: mention will be made of beta-hydroxy acids, in particular salicylic acids and derivatives thereof other than 5-n-octanoylsalicylic acid; urea; glycolic acid, citric acid, lactic acid, tartaric acid, malic acid or mandelic acid; 4-(2-hydroxyethyl)piperazine-1-propanesulphonic acid (HEPES); extract of Saphora

japonica; honey; N-acetylglucosamine; sodium methylglycine diacetate, alpha-hydroxy acids (AHAs), beta-hydroxy acids (BHAs), and mixtures thereof;

- Depigmenting agents: mention may be made of ceramides, vitamin C and derivatives thereof, in particular vitamin CG, CP and 3-O ethyl vitamin C, alpha- and beta-arbutin, ferulic acid, kojic acid, resorcinol and derivatives thereof, calcium D-pantetheine sulphonate, lipoic acid, ellagic acid, vitamin B3, phenylethyl resorcinol, for instance Symwhite 377<sup>®</sup> from the company Symrise, a kiwi fruit (*Actinidia chinensis*) juice sold by Gattefosse, an extract of *Paeonia suffruticosa* root, such as the product sold by the company Ichimaru Pharcos under the name Botanpi Liquid B<sup>®</sup>, an extract of brown sugar (*Saccharum officinarum*), such as the extract of molasses sold by the company Taiyo Kagaku under the name Molasses Liquid, a mixture of undecylenic acid and undecylenoyl phenyl alanine, such as Sepiwhite MSH<sup>®</sup> from Seppic;

- Antioxidants: mention may more particularly be made of tocopherol and esters thereof, in particular tocopheryl acetate; EDTA, ascorbic acid and derivatives thereof, in particular magnesium ascorbyl phosphate and ascorbyl glucoside; chelating agents, such as BHT, BHA, N,N'-bis(3,4,5-trimethoxybenzyl)ethylenediamine and its salts, and mixtures thereof;

### **GALENIC FORMULATION**

A gel composition according to the invention may be in the form of makeup compositions and/or care compositions for keratin materials, in particular for skin or lips.

Particularly, a composition according to the invention may be a BB product or a foundation especially to be applied on the face or neck, a product for masking dark circles, a concealer product, a tinted cream, a colored composition for care or for making up the skin, especially for the face or body or an after-sun composition.

A gel composition according to the invention may comprise at least one surfactant (emulsifier), chosen especially from amphoteric, anionic, cationic and nonionic surfactants, used alone or as a mixture.

The surfactants are generally present in the composition in a proportion that may range, for example, from 0.3% to 20% by weight, in particular from 0.5% to 15% by weight and more particularly from 1% to 10% by weight of surfactants relative to the total weight of the composition. These compositions are prepared according to the usual methods.

Throughout the description, including the claims, the term "comprising a" should be understood as being synonymous with "comprising at least one", unless otherwise mentioned.

The terms "between... and..." and "ranging from... to..." should be understood as being inclusive of the limits, unless otherwise specified.

The invention is illustrated in greater detail by the examples according to the invention described below. Unless otherwise mentioned, the amounts indicated are expressed as mass percentages of active material.

## EXAMPLES

### Example 1: Transparent gel with brown microcapsules for make-up result

Phase	INCI name	% weight
A1	WATER	qsp 100
	ACRYLATES/C10-30 ALKYL ACRYLATE CROSSPOLYMER (CARBOPOL ULTREZ 20 POLYMER® from LUBRIZOL)	0.70
A2	GLYCERIN	4.00
	DISODIUM EDTA	0.15
	BUTYLENE GLYCOL	6.00
	CAPRYLYL GLYCOL	0.25
B	WATER	31.00
	BIS-PEG-18 METHYL ETHER DIMETHYL SILANE (DOW CORNING 2501 COSMETIC WAX® from Dow Corning)	2.00
C	WATER	3.00
D1	BIOSACCHARIDE GUM-1	1.00
	PEG/PPG/POLYBUTYLENE GLYCOL-8/5/3 GLYCERIN (WILBRIDE S-753L® from Nof Corporation)	0.70

Phase	INCI name	% weight
D2	ALCOHOL	4.00
E	TITANIUM DIOXIDE (and) IRON OXIDES (and) MANNITOL (and) IRON OXIDES (and) ZEA MAYS (CORN) STARCH (and) IRON OXIDES (and) HYDROGENATED LECITHIN (Magic50-BW0105® from KPT)	2

Protocol of preparation:

Premix B at 70°C, mix until solution is clear

Main Mix

1. Phase A1 make the polymer well swelled in water, then, heat to 80°C-85°C
2. Add A2, mix until fully dissolved
3. Add phase B, fully dissolved, then cool to RT
4. Below 40°C, add in phase C.
5. Vacuum and slow mix, to reduce the gas bubbles in the bulk
6. Add phase D1, D2
7. Vacuum and slow mix, until temp to RT, and with few gas bubbles
8. Slowly add phase E (microcapsules), mix without scraper.
9. When microcapsules are fully dispersed evenly, stop mixing, check the pH and viscosity

The viscosity of the gel is around 20UD(Mobile 3) by Rheomat RM180, at 25°C according to the protocol disclosed above.

Aspect of the composition and evaluation after application

The gel presents a transparent and caring appearance and also covering makeup effects.

We obtain a gel with colored microcapsules in pure and clean appearance, with perfect stability under -20/20°C (5 cycle), room temperature (25°C, 2 months) , 37°C (2 months) and 45°C (2 months). The microcapsules release pigments during application on the skin with comfortable feeling during application, and confer natural

make-up result as it was a foundation, but with a very good balance of skincare efficacy perception (watery, moisturization and transparent) as well as makeup efficacy (proper coverage).

Example 2: Skin care gel

INCI name	% weight
WATER	Qsp 100
GLYCERIN	4
DISODIUM EDTA	0.15
NIACINAMIDE	4
BUTYLENE GLYCOL	7
CHLORPHENESIN	0.25
ACRYLATES/C10-30 ALKYL ACRYLATE CROSSPOLYMER (CARBOPOL ULTREZ 20 POLYMER® from LUBRIZOL)	0.7
BIS-PEG-18 METHYL ETHER DIMETHYL SILANE	2
PEG-60 HYDROGENATED CASTOR OIL	0.1
BIOSACCHARIDE GUM-1	1
SODIUM HYDROXIDE	0.24
ALCOHOL	5
CAPRYLOYL SALICYLIC ACID	0.15
TITANIUM DIOXIDE (and) MANNITOL (and) HYDROGENATED LECITHIN (and) IRON OXIDES (and) SYNTHETIC FLUORPHLOGOPITE (and) IRON OXIDES (and) RED 30 LAKE (and) IRON OXIDES (and) TIN OXIDE (and) ZEA MAYS (CORN) STARCH (Magic 60-WP0105® from KPT)	0.5
TITANIUM DIOXIDE (and) IRON OXIDES (and) MANNITOL (and) IRON OXIDES (and) ZEA MAYS (CORN) STARCH (and) IRON OXIDES (and) HYDROGENATED LECITHIN (Magic50-BW0105® from KPT)	0.2

The gel is prepared as the one disclosed in example 1.

After application on the skin, natural make-up result is obtained with a good balance of skincare efficacy perception (watery, moisturization and transparent) as well as makeup efficacy (proper coverage).

Example 3: Gelly skin care gel

INCI NAME	% weight
WATER	Qsp 100
GLYCEROL	4
1,3-BUTYLENE GLYCOL	8
VITAMINE B3 OR PP : NICOTINIC ACID AMIDE	4
ETHYLENE DIAMINE TETRACETIC ACID, DISODIUM SALT, 2 H <sub>2</sub> O	0.1
CARBOXYVINYLIC POLYMER SYNTHETIZED IN METHYLENE CHLORIDE	0.6
POLY DIMETHYLSILOXANE (VISCOSITY: 10 CST)	1
MIXTURE OF RETICULATED POLY DIMETHYLSILOXANE POLYALKYLENE AND POLY DIMETHYLSILOXANE (6 CST) 27/73	0.8
MIXTURE OF POLY DIHYDROXYLATED DIMETHYLSILOXANE ALPHA-OMEGA / POLY DIMETHYLSILOXANE 5 CST	1.2
n-OCTANOYL-5 SALICYLIC ACID	0.15
NO DENATURATED ABSOLUTE ETHYL ALCOHOL	5
TITANIUM DIOXIDE (and) IRON OXIDES (and) MANNITOL (and) IRON OXIDES (and) ZEA MAYS (CORN) STARCH (and) IRON OXIDES (and) HYDROGENATED LECITHIN (Magic50-BW0105® from KPT)	0.5

This gel composition is obtained according to classical method. After application on the skin, a healthy effect is obtained with a good balance of skincare efficacy perception (watery, moisturization and transparent) as well as makeup natural effect.

WHAT IS CLAIMED IS:

1. Changing colour composition on the form of a gel for caring for and/or making up keratin materials comprising, in a physiologically acceptable medium,

a) from 0,1 to 10% by weight preferably from 0,5 to 10% more preferably from 1 to 5% by weight relative to the weight of the composition of microcapsules containing releasable colorant(s), said microcapsules comprising:

- a core comprising one organic material,
- at least one layered coating surrounding said core, the layered coating comprising

at least one polymer,

at least one colorant,

and advantageously at least one lipid-based material,

b) at least 3% by weight, preferably at least 5% by weight, more preferably at least 8% by weight and advantageously at least 10 % by weight relative to the weight of the composition of at least one swelling agent, and

c) at least one hydrophilic gelifying agent.

2. Changing colour composition according to claim 1, wherein the microcapsules comprise at least two layers, preferably at least one organic inner layer and one organic outer layer of different colour.

3. Changing colour composition according to claim 1 or 2, wherein the core comprises at least one monosaccharide or its derivatives as said organic material, in particular a monosaccharide-polyol advantageously selected from mannitol, erythritol, xylitol, sorbitol and mixtures thereof, preferably mannitol.

4. Changing colour composition according to any preceding claims, wherein the layered coating surrounding said core comprises at least one hydrophilic polymer(s) selected from the group consisting of polysaccharides and derivatives, preferably the ones including one type of ose or several type of ose(s), preferably several type of ose(s) including at least D-glucose units, in particular starch and derivatives, cellulose or derivatives, and more preferably starch and derivatives.

5. Changing colour composition according to any preceding claims, wherein said microcapsules comprises at least:

- a inner core made of monosaccharide-polyol, preferably mannitol,
- at least two layers of different colour,

- at least one hydrophilic polymer preferably selected from polysaccharide or derivatives, and more preferably from starch or derivatives,
- and advantageously at least one lipid based material, preferably an amphiphilic compound, more preferably a phospholipid, even more preferably phosphoacylglycerol such as hydrogenated lecithin.

6. Changing colour composition according to anyone of the preceding claims wherein the gel is transparent or translucent.

7 Changing colour composition according to anyone of the preceding claims comprising at least one hydrophilic gelifying agent chosen from water-soluble or water dispersible polymers.

8 .Changing colour composition according to the preceding claim wherein the water-soluble or water dispersible polymers is chosen from:

- modified or unmodified carboxyvinyl polymers ;
- polyacrylates ;
- Polymethacrylates ;
- polyacrylamides; optionally crosslinked and/or neutralized 2-acrylamido-2-methylpropanesulfonic acid polymers and copolymers ;
- crosslinked anionic copolymers of acrylamide and of AMPS ;
- polysaccharide biopolymers, for instance xanthan gum, guar gum, carob gum, acacia gum, scleroglucans, chitin and chitosan derivatives, carrageenans, gellans, alginates,
- celluloses such as microcrystalline cellulose, carboxymethylcellulose, hydroxymethylcellulose and hydroxypropylcellulose;
- and mixtures thereof.

9. Changing colour composition according to the preceding claim wherein the water-soluble or water dispersible polymers is chosen from Acrylates/C<sub>10-30</sub> Alkyl Acrylate Crosspolymer ; Ammonium acryloyldimethyl Taurate/Steareth-8 Methacrylate copolymer ; Acrylates copolymer ; Ammonium acryloyldimethyl taurate/steareth-25 Methacrylate Crosspolymer ; Ammonium acryloyldimethyl taurate such, and xanthan gum.

10. Changing colour composition according to one of the preceding claims wherein the hydrophilic gelifying agent(s) are in an amount ranging from 0.001 to 10 % by weight, preferably 0.01 to 5% by weight and more preferably from 0.05 to 3% by weight relative to the total weight of the composition.

11. Changing colour composition according to one of the preceding claims further comprising one or more water soluble emollient(s) and/or lipid(s) with a polar moiety.

12. Cosmetic process for caring for and/or making up keratinic materials, comprising application on said keratinic materials in particular on the skin of a composition as defined according to any preceding claims.

# INTERNATIONAL SEARCH REPORT

International application No.  
PCT/CN2012/070476

<b>A. CLASSIFICATION OF SUBJECT MATTER</b>		
See extra sheet		
According to International Patent Classification (IPC) or to both national classification and IPC		
<b>B. FIELDS SEARCHED</b>		
Minimum documentation searched (classification system followed by classification symbols)		
IPC: A61K, A61Q		
Documentation searched other than minimum documentation to the extent that such documents are included in the fields searched		
Electronic data base consulted during the international search (name of data base and, where practicable, search terms used)		
DATABASES: DWPI, SIPOABS, CPRSABS, CNABS, CNTXT, EPODOC, CNKI; SEARCH TERMS: changing colo(u)r, colo(u)r changing, gel, microcapsul+, encapsul+, capsu+, core, swelling agent, gelifying agent, mannitol, pigment, colorant, coloring agent		
<b>C. DOCUMENTS CONSIDERED TO BE RELEVANT</b>		
Category*	Citation of document, with indication, where appropriate, of the relevant passages	Relevant to claim No.
A	JP 2011079804A (DAITO KASEI KOGYO KK), 21 Apr. 2011 (21.04.2011), see claims 1-5, manufacture examples 1-5, examples 1-6	1-12
A	CN 102088946A (TAGRA BIOTECHNOLOGIES LTD), 08 Jun. 2011 (08.06.2011), see claims 1-21, example 1	1-12
<input type="checkbox"/> Further documents are listed in the continuation of Box C. <input checked="" type="checkbox"/> See patent family annex.		
* Special categories of cited documents:	“T” later document published after the international filing date or priority date and not in conflict with the application but cited to understand the principle or theory underlying the invention	
“A” document defining the general state of the art which is not considered to be of particular relevance	“X” document of particular relevance; the claimed invention cannot be considered novel or cannot be considered to involve an inventive step when the document is taken alone	
“E” earlier application or patent but published on or after the international filing date	“Y” document of particular relevance; the claimed invention cannot be considered to involve an inventive step when the document is combined with one or more other such documents, such combination being obvious to a person skilled in the art	
“L” document which may throw doubts on priority claim (S) or which is cited to establish the publication date of another citation or other special reason (as specified)	“&” document member of the same patent family	
“O” document referring to an oral disclosure, use, exhibition or other means		
“P” document published prior to the international filing date but later than the priority date claimed		
Date of the actual completion of the international search 16 Oct. 2012(16.10.2012)	Date of mailing of the international search report <b>25 Oct. 2012 (25.10.2012)</b>	
Name and mailing address of the ISA/CN The State Intellectual Property Office, the P.R.China 6 Xitucheng Rd., Jimen Bridge, Haidian District, Beijing, China 100088 Facsimile No. 86-10-62019451	Authorized officer  <b>LIANG Jingchen</b> Telephone No. (86-10)62412201	

**INTERNATIONAL SEARCH REPORT**  
Information on patent family members

International application No.  
PCT/CN2012/070476

Patent Documents referred in the Report	Publication Date	Patent Family	Publication Date
JP2011079804A	21.04.2011	None	
CN102088946A	08.06.2011	WO2009138978A2	19.11.2009
		WO2009138978A3	15.07.2010
		EP2293761A2	16.03.2011
		KR20110021853A	04.03.2011
		INMUMNP201002651E	18.03.2011
		JP2011519969A	14.07.2011
		US2011229536A1	22.09.2011

# INTERNATIONAL SEARCH REPORT

International application No.

PCT/CN2012/070476

Continuation of classification of subject matter:

A61K 8/02 (2006.01) i

A61K 8/11 (2006.01) i

A61Q 19/00 (2006.01) i