

BEST AVAILABLE COPY

R. B. DULA.

MACHINE FOR PRESSING AND FINISHING PLUG TOBACCO.

APPLICATION FILED JAN. 2, 1914.

1,154,913.

Patented Sept. 28, 1915.

8 SHEETS—SHEET 1.

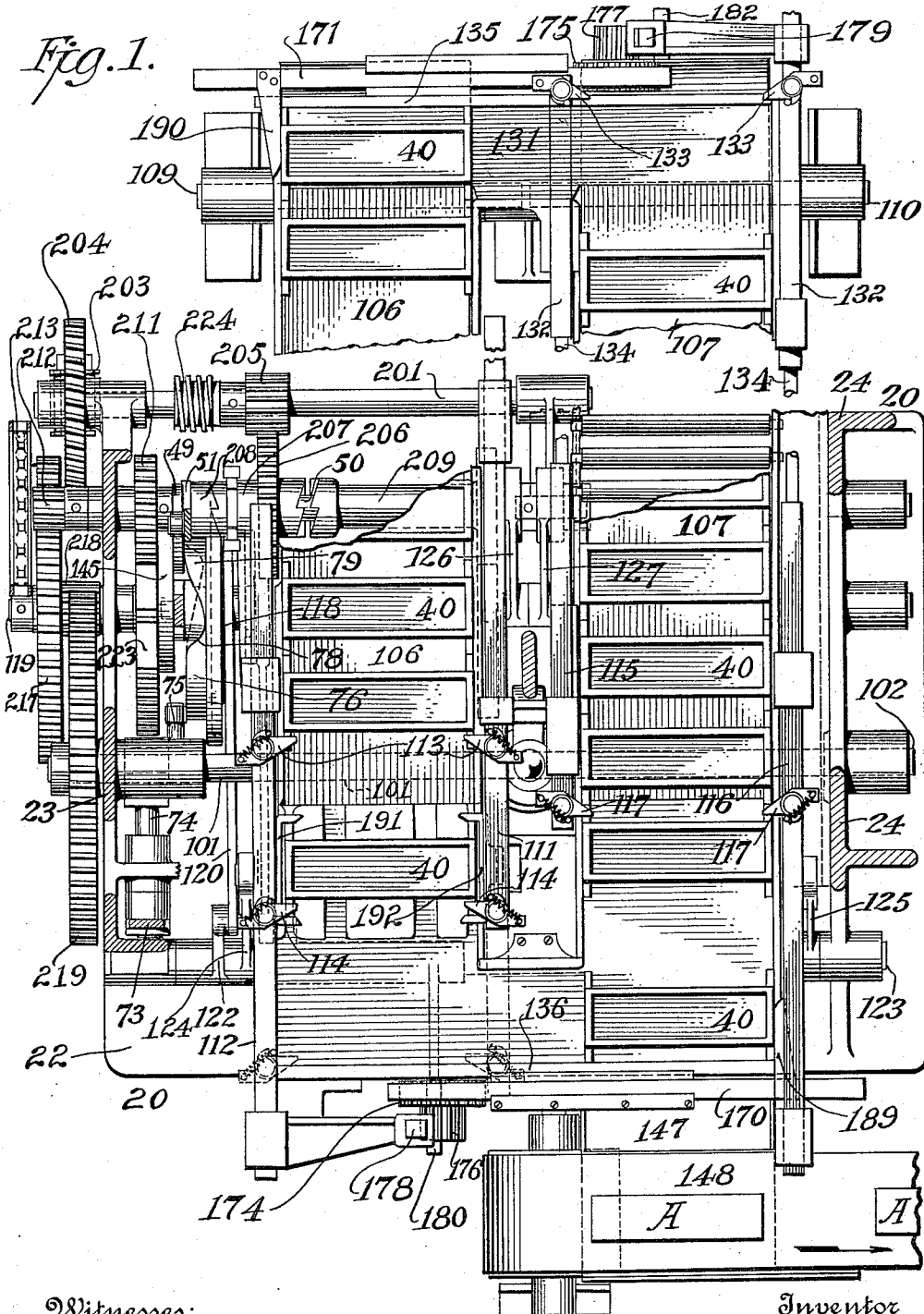

Witnesses:  
W. Hawkins.  
A. R. Appleman

Inventor  
Robert B. Dula  
By his Attorneys  
Meyers, Crishman & Co.

R. B. DULA.  
 MACHINE FOR PRESSING AND FINISHING PLUG TOBACCO.  
 APPLICATION FILED JAN. 2, 1914.

1,154,913.

Patented Sept. 28, 1915.

8 SHEETS—SHEET 2.

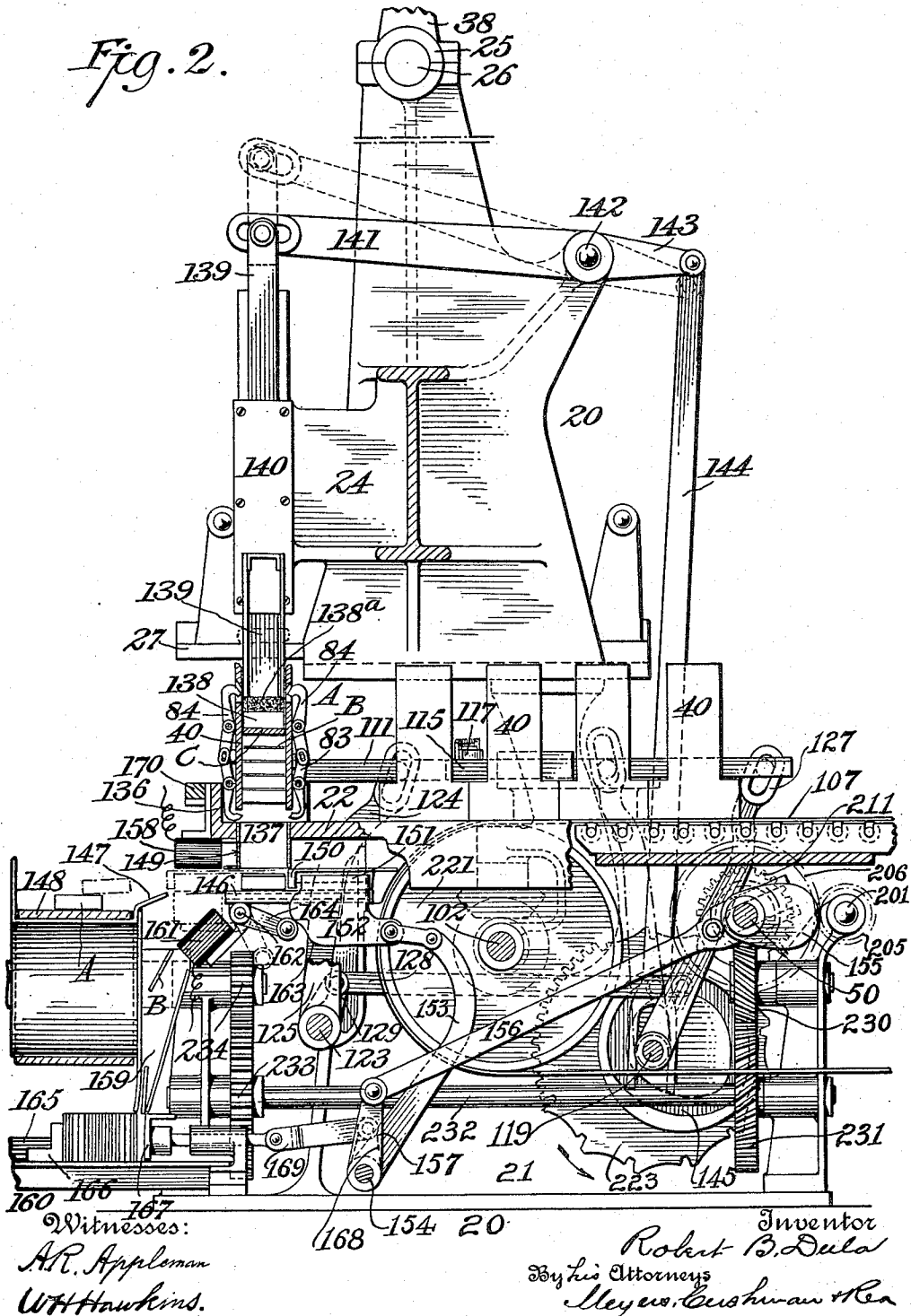

R. B. DULA.  
MACHINE FOR PRESSING AND FINISHING PLUG TOBACCO.  
APPLICATION FILED JAN. 2, 1914.

1,154,913.

Patented Sept. 28, 1915.

8 SHEETS—SHEET 3.

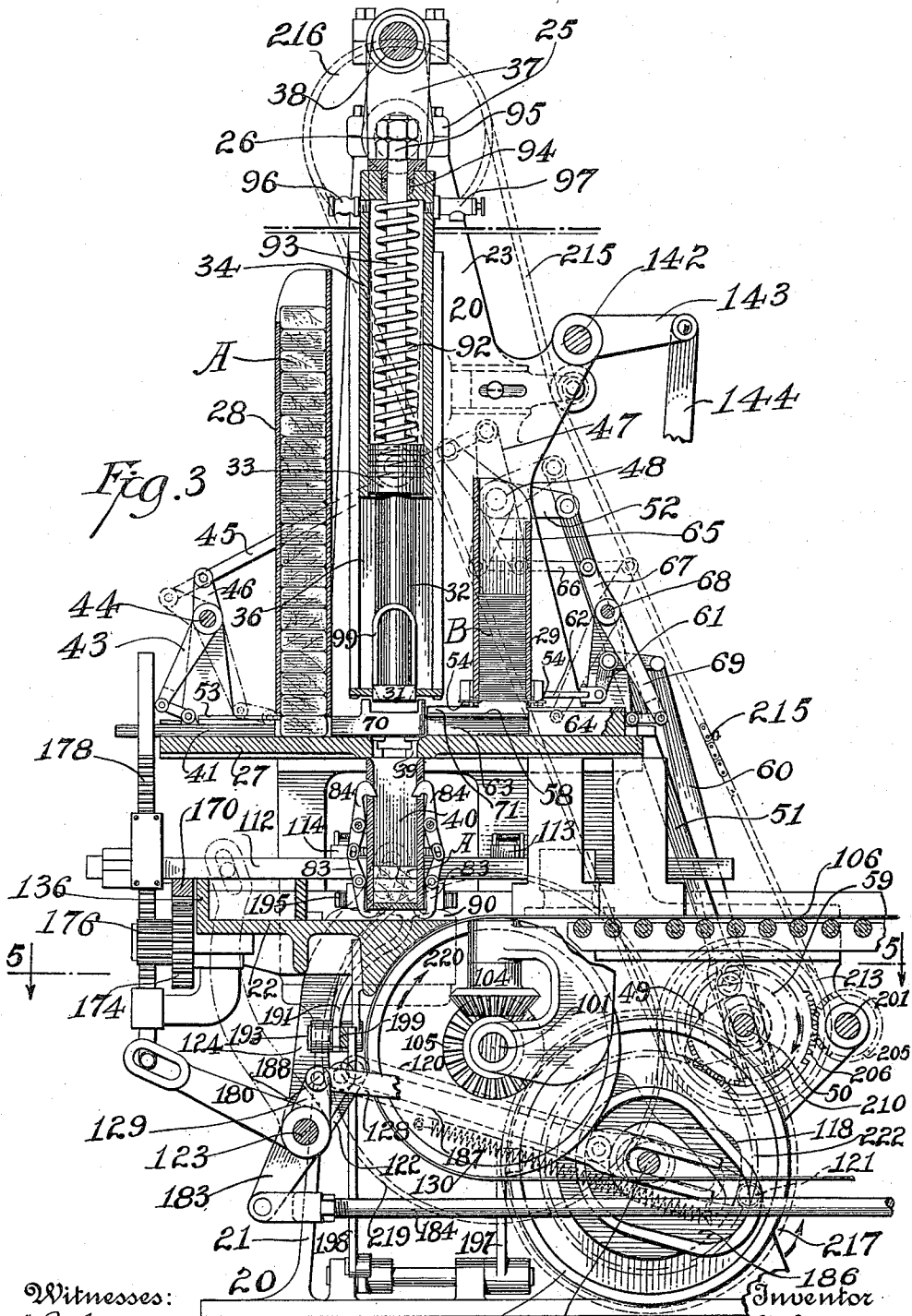

Witnesses:  
A. R. Appleman  
W. H. Hankins

Inventor  
R. B. Dula  
by 119 Robert B. Dula  
his Attorneys  
Meyers, Cushman & Ken



R. B. DULA.  
 MACHINE FOR PRESSING AND FINISHING PLUG TOBACCO.  
 APPLICATION FILED JAN. 2, 1914.

1,154,913.

Patented Sept. 28, 1915.

8 SHEETS—SHEET 5.

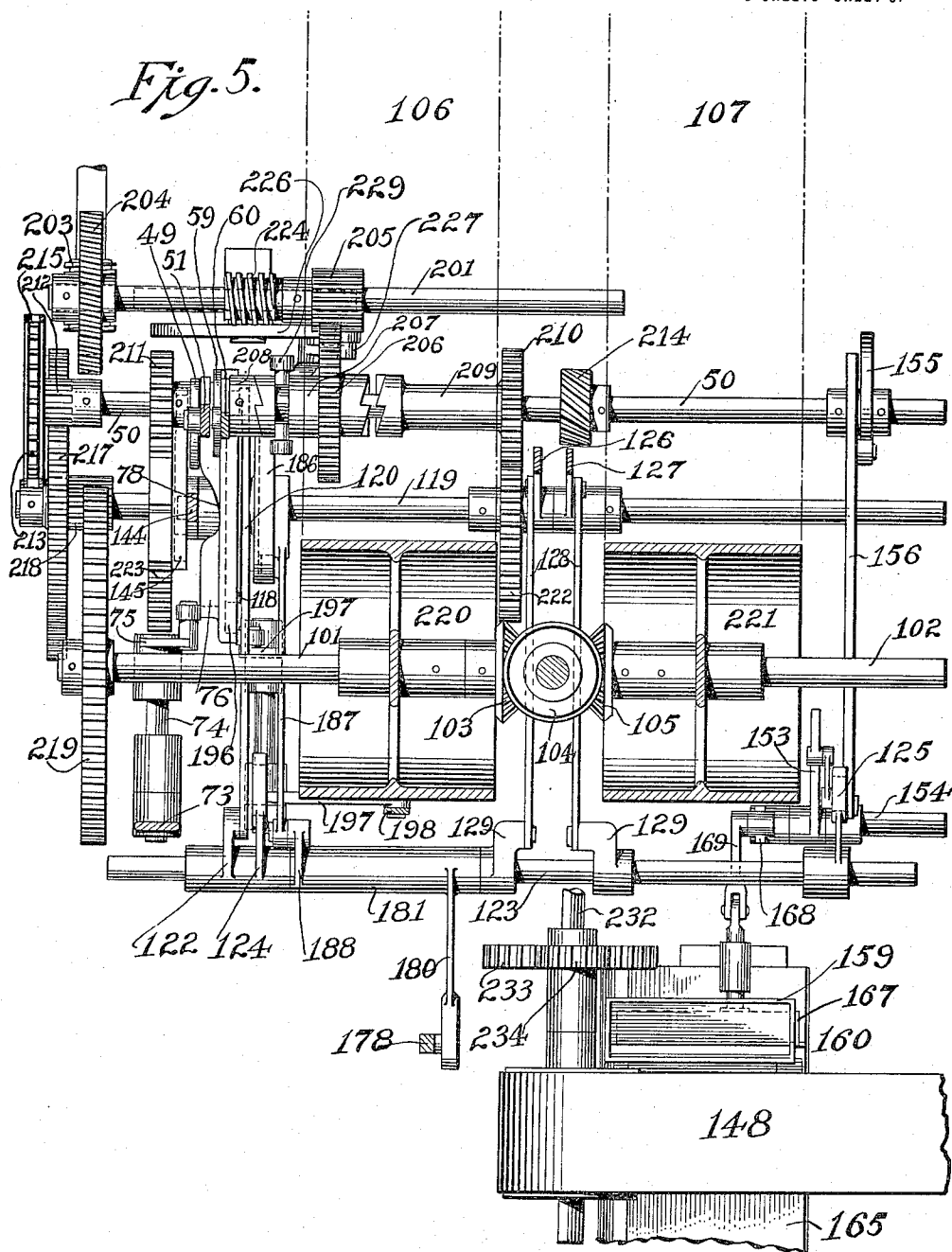

Witnesses:  
 A. R. Appleman  
 W. H. Hawkins.

Inventor  
 Robert B. Dula  
 By his Attorneys  
 Meyers, Bushman & Co.

R. B. DULA.  
 MACHINE FOR PRESSING AND FINISHING PLUG TOBACCO.  
 APPLICATION FILED JAN. 2, 1914.

1,154,913.

Patented Sept. 28, 1915.

8 SHEETS—SHEET 6.

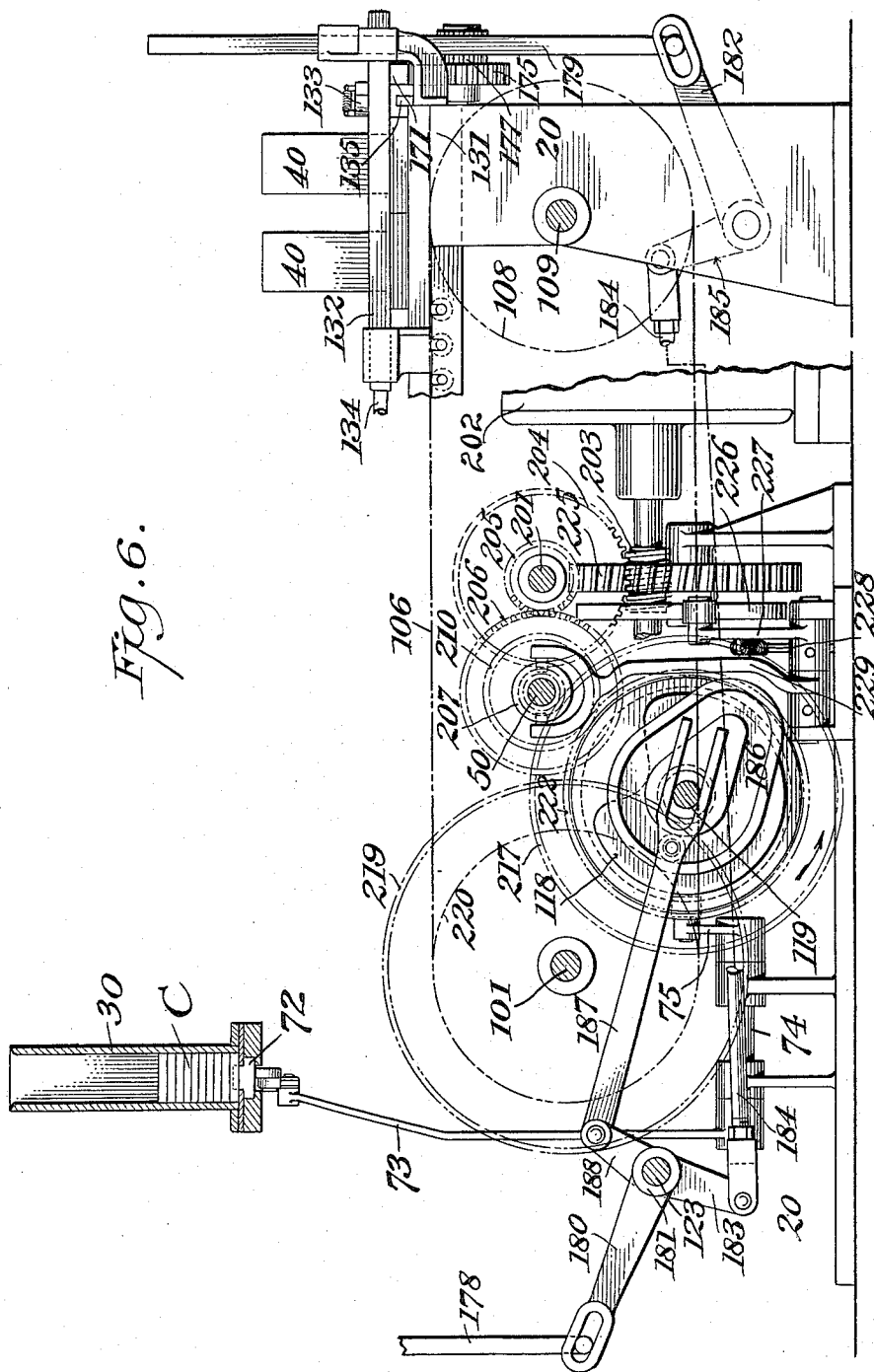

Fig. 6.

Witnesses:  
*A. R. Appleman*  
*W. H. Hawkins.*

Inventor  
*Robert B. Dula*  
 By his Attorneys  
*Meyers, Cushman & Ken*

R. B. DULA.  
 MACHINE FOR PRESSING AND FINISHING PLUG TOBACCO.  
 APPLICATION FILED JAN. 2, 1914.

1,154,913.

Patented Sept. 28, 1915.  
 8 SHEETS—SHEET 7.

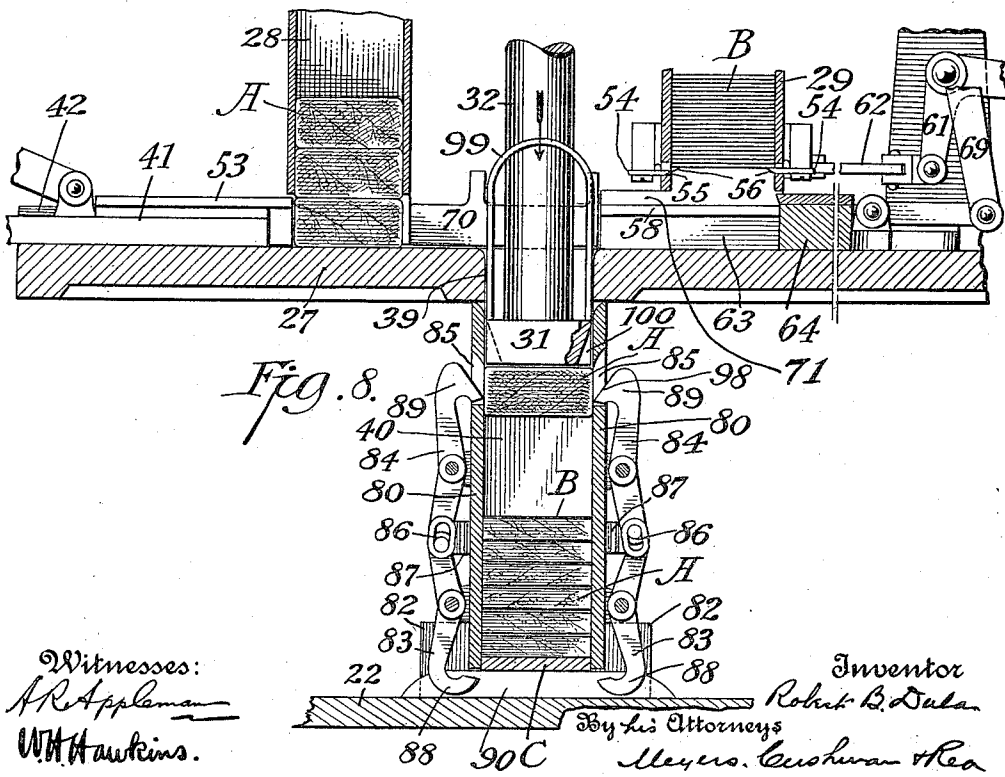
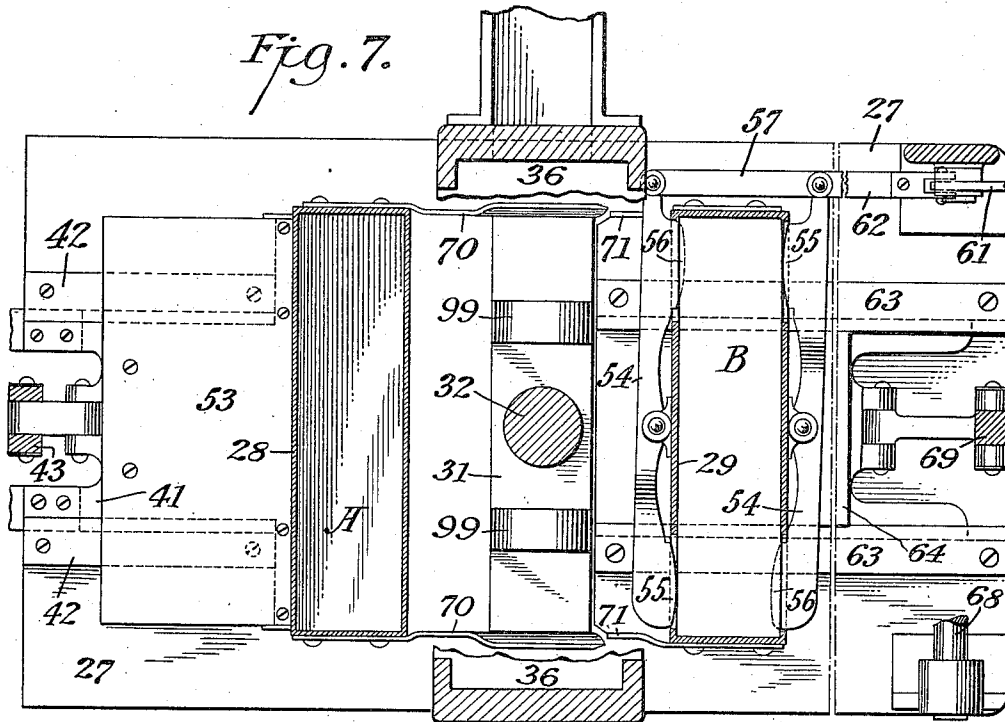

R. B. DULA.  
MACHINE FOR PRESSING AND FINISHING PLUG TOBACCO.  
APPLICATION FILED JAN. 2, 1914.

1,154,913.

Patented Sept. 28, 1915.  
8 SHEETS—SHEET 8.

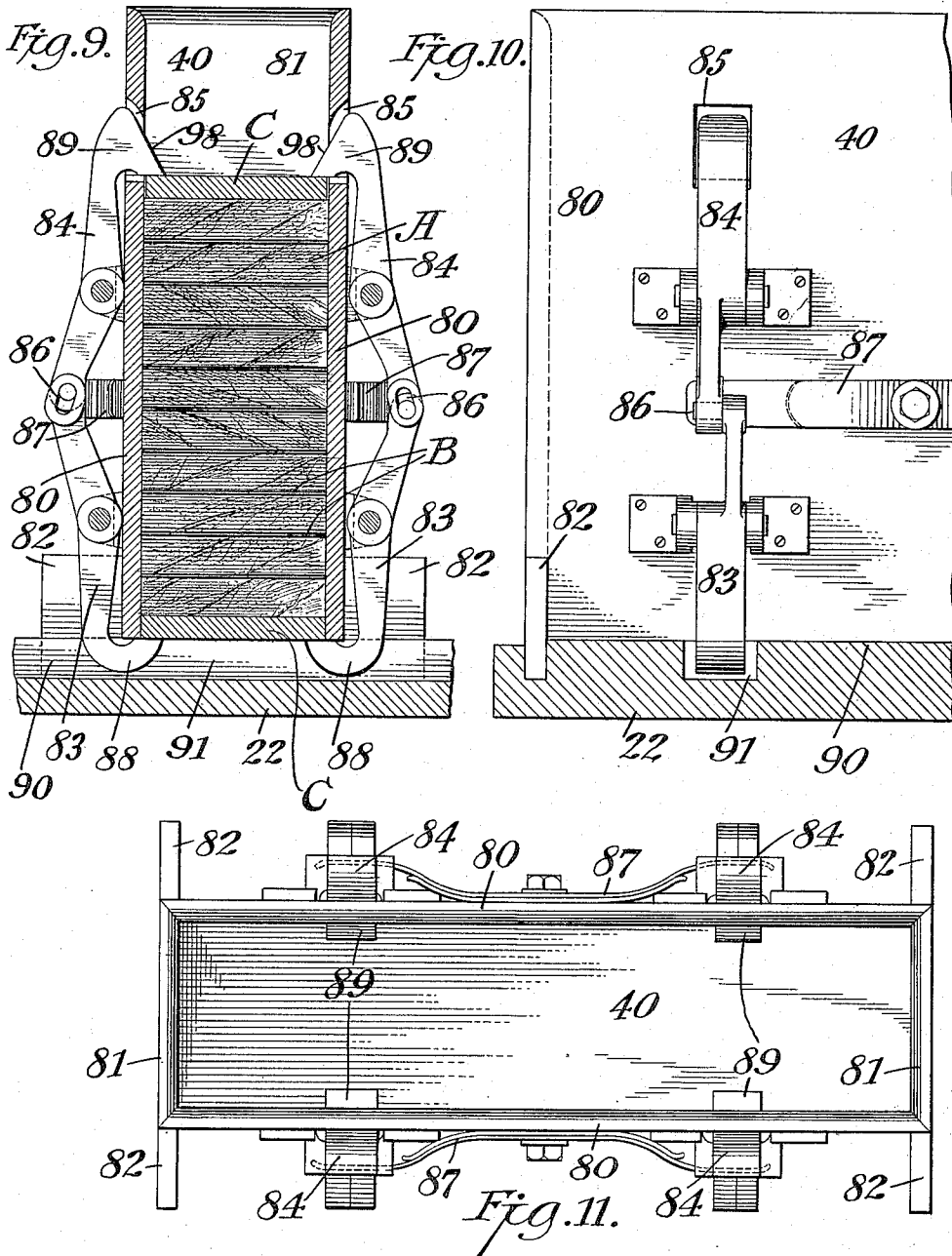

Witnesses:  
*A. R. Appleman*  
*W. Hawkins.*

Inventor  
*Robert B. Dula*  
By his Attorneys  
*Meyers, Cushman & Rea*

## UNITED STATES PATENT OFFICE.

ROBERT B. DULA, OF TARRYTOWN, NEW YORK.

MACHINE FOR PRESSING AND FINISHING PLUG-TOBACCO.

1,154,913.

Specification of Letters Patent.

Patented Sept. 28, 1915.

Application filed January 2, 1914. Serial No. 810,007.

*To all whom it may concern:*

Be it known that I, ROBERT B. DULA, a citizen of the United States, residing at Tarrytown, in the county of Westchester and State of New York, have invented new and useful Improvements in Machines for Pressing and Finishing Plug-Tobacco, of which the following is a specification.

This invention relates to machines for pressing and finishing plug tobacco, and has for its object to provide a completely organized machine for automatically feeding into pressing molds or frames partly formed plugs of tobacco, and a separating plate between each plug, pressing each plug as it enters the mold and, after a predetermined number have been fed into a mold, hold said plugs under compression between top and bottom pressing plates also automatically fed to the mold in proper time; removing in succession the filled molds from the filling position and placing them on a slowly moving conveyer that transports them from the machine and back again, the time consumed in making the cycle over the conveyer being sufficiently long for the compressed plugs to set; ejecting the plugs separating plates and pressing plates by suitable automatic discharging mechanism that push them from the molds onto a temporary support; separating the plugs from the plates as they are removed from the support and delivering said plugs to a conveyer which carries them to packing position or wherever desired, the plates passing separately from the machine into position to be gathered and returned to their respective hoppers and finally transferring the empty molds from the discharging mechanism back again to the filling mechanism, the entire series of operations being carried out in order without manual assistance.

Another object of the invention is to provide a pressing mold or frame of novel construction into which have been fed a predetermined number of plugs and separating plates therebetween, and a pressing plate above and below the plugs, which pressing plates form a temporary top and bottom for said mold, and after the plugs have been pressed individually and collectively, to automatically lock said pressing plates on the compressed plugs and hold them thus until fully set.

A further object of the invention is to provide a pressing means that will give each

plug an individual maximum compression when fed into the mold and the same pressure to all the previously pressed plugs in said mold as it is being filled, automatic means being provided to insure the maximum pressure and prevent any increase thereof.

Other objects of the invention reside in the novel transporting and transferring means for moving the pressed molds while the plugs are setting; means for separating the plates from the plugs and delivering them upon separate receivers, and means for performing other operations not here enumerated but which are described in detail in the following description and illustrated in the accompanying drawings, in which:—

Figure 1 is a plan view of the machine with the upper portion of the frame and attached parts removed. Fig. 2 is a section view on the line 2—2 of Fig. 4. Fig. 3 is a similar sectional view on the line 3—3 of the same figure. Fig. 4 is a front elevation of the machine partly in section. Fig. 5 is a horizontal sectional view on the line 5—5 Fig. 3. Fig. 6 is a sectional view in a plane parallel to plane of section of Fig. 2 illustrating only some special parts of the invention. Fig. 7 is an enlarged plan view partly in section showing the plug hopper, separating plate hopper, and means for feeding plugs and plates to the plunger. Fig. 8 is a central vertical section view of the same parts. Fig. 9 is an enlarged vertical sectional view of the mold-box or frame. Fig. 10 is an elevation of one side of the same. Fig. 11 is a top plan view of the mold-box.

In the drawings 20 indicates the supporting frame as a whole, including standards 21 that rise from the floor and support a horizontal table 22, above which the standards rise, as at 23, 24, to a suitable height and at the top are provided with bearings 25 for a crank shaft 26, the purpose of which will be described later.

For simplifying the description, that side of the machine in Fig. 1 at the bottom of the sheet will be called the front, the opposite side the rear, the side on the right the right hand side, and the side on the left the left hand side.

Above the table 22 and parallel therewith is a shelf 27 sustained by brackets that project inwardly from the standard extensions 23, 24, upon which shelf is secured a hopper

28 for the material A to be pressed in the present instance bars of plug tobacco partly compressed; another hopper 29 containing the metal separating plates B that are inserted between the plugs, and a third hopper 30 for holding the pressing plates C that are placed at the top and bottom of a stack of plugs and between which they are pressed.

The material or plug hopper 28 is mounted in vertical position on the shelf 27 a short distance from its front edge, and extends as high as desired, being open both at the top for the insertion of plugs to be pressed and finished, and at the bottom through which they are ejected one at a time. Behind the hopper 28 and spaced therefrom is the hopper 29 for the separating plates preferably of less height than the hopper 28 and open at top and bottom for insertion and ejection of the plates. Between the hoppers 28, 29, is a vertically reciprocating pressing plunger 31 secured on the lower end of a piston rod 32 provided with a piston 33 on its upper end that may travel in a cylinder 34. On opposite sides of the cylinder are vertical sliding bars 35 secured on the bottom of the cylinder and movable in guides 36 on the standard extensions 23, 24. Pivotaly connected to the cylinder 34 are two connecting rods 37 that extend upward to a crank 38 on the shaft 26, the rotation of which reciprocates the cylinder, that is, it raises and lowers the cylinder, piston and pressing plunger. Fastened on the shelf 22 between the hoppers 28, 29 but offset therefrom is the pressing plate hopper 30 and like the other hoppers is open at the top and bottom.

When the plunger 31 is in its highest position, there is sufficient room for a plug A to be pushed between its under side and the shelf 27. Directly under the plunger is an opening 39 in the shelf 27 of the size of the plug through which opening the plugs A, separating plates B and pressing plates C are pushed by the plunger into pressing molds or frames 40 when fed thereover by means now to be described.

On the shelf 27 in front of the hopper 28 is a horizontally reciprocating pusher 41 movable in slides 42 and adapted to travel beneath the hopper toward the opening 39. The pusher at its rear end is as wide as the plugs A are long and about as high as a partly compressed plug is thick, to engage plugs singly and push them accurately to the opening 39 and beneath the plunger. The forward end of the pusher is connected to a lever 43 on a rock shaft 44 journaled in bearings above the shelf 27, said shaft being rocked by a connecting rod 45 pivoted at one end to an arm 46 on said rock shaft and at its other end to an arm 47 on a

second rock shaft 48 to which motion is imparted from a cam 49, fixed on a shaft 50, that reciprocates a bar 51 connected to an arm 52 on the rock shaft 48. I prefer to feed the plugs individually into the mold-box. With each rotation of the cam, the pusher is moved at the proper time beneath the hopper and there engaging the lowermost plug A, carries it to the opening 39 and then returns, ready to feed another plug. A plate 53 is fastened on the top of the pusher of sufficient width in the direction of movement to support all the plugs in the hopper above the bottom one until the withdrawal of the pusher, whereupon they descend to place another plug in position to be ejected.

At the bottom of the hopper 29 containing the separating plates B are two rocking plates 54, see Fig. 7, that support the plates B, pivoted intermediate their ends to the front and rear walls respectively of said hopper to swing in horizontal planes. These plates 54 are substantially as long as the separating plates B, their inner edges at each end projecting toward the hopper in the form of blades 55, 56 that alternately swing beneath the separating plates in said hopper as the plates 54 are rocked. The blades 56 which are a little higher than the blades 55 are on opposite ends of the plates 54 so that when said plates, connected at one end by a link 57, are rocked, they swing in parallel, carrying alternately the two blades 56 beneath diagonally opposite corners of the separating plates and the blades 55 away therefrom. The latter blades between operations extend under the hopper and sustain the separating plates at two diagonally opposite corners, the other corners being unsupported. When the blades 55 which are a little lower than the bottom plate, swing inwardly, the stack of plates descend until they rest on said blades. After a short interval, the horizontal plates 54 are moved in the opposite direction, withdrawing the blades 55 from beneath the stack and thrusting the blades 56, which have knife edges, between the bottom plate and the plate next above, releasing the bottom plate which thereupon drops upon horizontal supporting rails 58 beneath the hopper in position to be carried to the opening 39, as more clearly shown in Fig. 8.

The blades are rocked by a cam 59, Figs. 3 and 5 fixed on the shaft 50, that actuates a rod 60 connected to one arm of an elbow lever 61, from the other arm of which a link 62 extends to one of the rocking plates 54.

In guides 63 on the shelf 27 beneath the hopper 29 is mounted a slide 64 that projects a short distance above the supporting rails 58 and travels to and from the opening 39 in said shelf, the forward edge of which slide engages the separating plate

on the rails and feeds it to the opening 39 simultaneously with the plug A and just above the same, the supporting rails 58 being at the proper height to maintain the plate above the plug. The slide is operated by a lever 65 on the same shaft 48 with the lever 52, connected by a link 66 with an arm 67 on a shaft 68 from which a second arm 69 depends, the free end of which is connected to the slide 64.

The plugs A are guided to the opening 39 and centered thereover by spring fingers 70, see Figs. 3 and 7, that project rearwardly in a horizontal direction from the bottom of the hopper 28 and bear on the ends of the plug. Other spring fingers 71 extend forwardly from the hopper 29 to guide and center the separating plates. After a plug A and separating plate B have been positioned above the opening 39, they are pushed by the plunger 31 into the pressing mold or frame 40 just under said opening, but before the first plug and plate are fed to the mold or frame, and after the last plug and plate have been pushed therein, a pressing plate C in each instance must be placed in the mold, these plates constituting respectively, the bottom and top of the mold 40 as more clearly shown in Fig. 9. To do this the pressure plate hopper 30 is secured on the shelf 27 at the left hand end of the opening 39, and into the bottom of said hopper a slide 72 projects that engages the lowest pressure plate and pushes it above the opening 39 through which it drops into the mold or frame 40. The reciprocation of the slide 72 is timed to feed a plate C into the mold before and after a predetermined number of plugs have been fed from the hopper 28. The slide is reciprocated by an arm 73, see Figs. 5 and 6, connected thereto, fixed on a short shaft 74 rocking in bearings on the standards 21 below the table 22, said shaft having thereon a second arm 75 held against a cam 76 by a spring 77 connected to the arm 73 and to the frame. The cam 76 is formed with two depressions 78, 79, of such shape and so spaced from each other that as the cam rotates, the depressions will be brought in succession opposite the end of arm 75 which will drop into said depressions under the tension of spring 77 and each time permit the arm 73 to operate the slide quickly and feed a pressure plate from the hopper 30.

The pressing molds or frames 40, as shown in detail in Figs. 9, 10, and 11, are strong rectangular box like containers having a cross sectional area equal to the length and width of the finished plug and a height to contain any desired number of plugs, in the present embodiment, the pressing molds are designed to hold ten plugs. These molds have parallel front and rear sides 80, parallel ends 81, and are open from top to bottom.

Each end 80 has forwardly and rearwardly projecting feet 82 that give the mold a firm support on the table 27 and prevent the sides of adjacent molds contacting. Pivotaly mounted upon the sides 80 of the mold are a plurality of latches, in the instance shown, four latches are carried on each side, two, as 83, extending downward beneath the mold, and two, shown at 84, directed upward and enter the mold through slots 85 near the top of the sides 80. The tails of the latches 83, 84 at each end of each side overlap and are joined by a pin and slot connection 86 so as to operate in unison, and are normally held away from the sides by springs 87 that keep the hooked ends 88, 89 of the latches respectively beneath the mold and within the slots 85. The feet 82 project below the bottom of the mold and stand on the table 22, the space between the feet when the mold is in place below the opening 39 in the shelf 27 being filled by an elevated block 90 as high as the bottom of the mold upon which the lower pressure plate C in the mold bears. Grooves 91 are made in the block for the lower latches 83 to pass into. The latches 83, 84 hold the plugs in the mold under continuous pressure by means of their hooked ends which engage over the edges of the upper and lower pressure plates C.

A mold, such as described, is placed by hand, or automatically by means hereinafter described, beneath the opening 39, whereupon a pressing plate C is fed from the hopper 30 and falls through said opening to the bottom of the mold and is there supported on the block 90. Plugs A of tobacco and separating plates B are then fed successively into the mold until the predetermined number of plugs and separating plates have entered therein. A second pressure plate is then fed into the mold and the stack of plugs, separating plates and pressure plates are held under pressure between the upper and lower latch hooks 88, 89.

As each plug and plate is fed over the opening 39, the plunger 31 descends, pushing the plug and plate to the bottom of the mold and compressing said plug between the plunger and the pressure plate. It is to be understood that the plugs in the hopper 28 have been only partly pressed while substantially as long and as wide as the finished plug, they are thicker and less compact, hence a finishing pressure or pressures is necessary before they are ready for the market. The plunger 31, as heretofore described, is on the lower end of a piston rod 32 the upper end of which carries a piston that may travel in a cylinder 34, said parts being reciprocated by the crank 38 more clearly shown in Figs. 3 and 4. The piston 33 is held normally at the lower end of the cylinder by a coil spring 92 maintained un-

der compression between said piston and the head of the cylinder. A guiding rod 93 extends from the piston longitudinally of the cylinder, through the spring and out  
 5 through a stuffing box 94 in the cylinder head, where its end is threaded and fitted with nuts 95 that serve as stops to limit the downward movement of the piston. At the top of the cylinder is a check valve 96, see  
 10 Fig. 3, that admits air into the cylinder during the downward movement of the piston, and a regulating valve 97 that can be adjusted to permit the escape of air from the cylinder during the upward movement of  
 15 the piston when the pressure in said cylinder tends to exceed a determined point. The plunger 31 on its downward movement to push the plugs into the mold and compress them is, by the means described, yieldingly  
 20 supported so that as soon as a plug upon entering the mold encounters the bottom pressure plate or the previously compressed plug, the movement of the plunger in unison with the cylinder is arrested, the latter however continues its descent, but the piston and  
 25 plunger move only as the plug yields to pressure. The piston is thus pushed up in the cylinder compressing the air therein and increasing the pressure on the plugs until the predetermined pressure is reached, whereupon the relief valve 97 is forced open and excess pressure permitted to escape. The pressure on the plugs thereafter remains constant during the continuance of  
 30 the downward throw of the crank 38. It will be seen, therefore, that as each plug and separating plate are fed into the mold, the plug receives a preliminary pressure to partly compress it. The plunger 31 continues to reciprocate, pushing a plug and a separating plate with each downward  
 40 stroke into the mold and compressing the plugs. This continues until the mold has received its full complement of plugs, whereupon the movement of the plunger is stopped, the filled mold removed and an empty one inserted in its place. Each plug entering the mold engages the inclined edges 98 of the hooked ends 89 of the upper  
 45 latches 84 and push the latches outward, strips 99 on the plunger holding them outward until the plunger withdraws from the mold. With the last plug and separating sheet, the top pressure plate enters the mold  
 50 and the three are pushed down until the latter plate passes the hooked ends 89 before the relief valve 97 opens and the plunger stops. The plates C are of sufficient thickness to be rigid so that they will not bulge greatly under pressure. This imparts to all the plugs of the pack within the mold a final pressure which is maintained for a sufficiently long period to enable the plugs to set, so that when removed from the mold the plugs will  
 60 be of equal thickness, which is rendered pos-

sible because each plug contains the same quantity of tobacco, and the length and width of each being the same, each plug will be subjected to the same continuous final pressure. The two ends of the plunger have  
 70 each a notch 100 therein which, when the plunger stops after the last plug is pressed, are opposite the hooked ends 89 and into which said hooked ends enter, permitting them and the hooked ends of the lower  
 75 latches 83 to engage the edges of the upper and lower pressure plates and prevent expansion of the plugs.

The separating plates are made of metal and have smooth surfaces which contact  
 80 with the plugs, and owing to the continuous pressure sustained by the plugs and plates for such a long time, the sides of the plugs when removed from the molds will be smooth and highly finished. The separating  
 85 plates may have on one or both sides one or more characters in relief, as the trademark, a name or the like that is impressed in the plug while under pressure, also ribs equally spaced may be formed across the  
 90 plates to impress transverse grooves in the plugs for indicating lines of division thereon. These relief characters and ribs are not necessary however, and perfectly smooth plates may be used if desired. 95

After the top and bottom pressure plates have been secured by the latches, the molds may be removed by hand and stored for a sufficient length of time for the plugs to set, and then opened and the plugs and plates removed manually, but in an organized automatic machine herein illustrated and described, suitable means are provided for automatically removing the molds from the filling position onto a conveying mechanism  
 100 that transports them slowly from the machine and back again to a discharging mechanism that ejects the plugs and plates from the mold, separates the plugs and plates and delivers them where desired, and returns the  
 110 molds to be again filled, the time required for the complete cycle of movement being sufficiently long for the plugs to thoroughly set. The automatic means for transporting the molds from the filling to the discharge  
 115 position will now be described.

Extending crosswise of the machine below the table 22 from about the center toward the left side is a shaft 101, see Figs. 1, 2, 3, and 6. A second shaft 102, in line with  
 120 shaft 101, extends to the right side. A miter gear 103 on shaft 101 drives an intermediate miter gear 104 that meshes with a similar gear 105 on the shaft 102 and turns it in a direction opposite that of shaft 101.  
 125 Secured on each shaft is a belt pulley or drum around which pass conveyer belts 106, 107 that extend horizontally any desired distance from the rear of the machine to pulleys 108 on shafts 109, 110. The top of the 130

conveyer belt 106 travels from the machine and belt 107 toward the machine, and may be supported on a series of rollers, as shown or by other means. On these two belts the filled molds are carried very slowly by an intermittent movement away from the machine and back again to be emptied, the time required for the entire cycle being about two hours, this time being necessary for the compressed plugs to set so as not to expand when released from pressure. The receiving end of the outgoing belt 106 and the discharge end of incoming belt 107 are a short distance in rear of the filling position of the molds 40, which, after being filled are placed upon the belt 106 and others removed from the belt 107 by the following means.

On the right and left sides of the line of travel of the outgoing molds are two horizontal bars 111, 112, mounted to reciprocate in suitable supports and each provided on its upper side with two pawls 113, 114 spaced apart and mounted on pivots. The free ends of the pawls on each bar project toward those on the other bar and are sufficiently long to engage and move the molds as the bars travel rearwardly, but yield on the return movement of the bars if they contact with a mold. Similar but shorter reciprocating bars 115, 116, are disposed on opposite sides of the incoming belt 107; these bars however have each only one pawl 117 to remove the filled molds from the belt and carry them to discharge position.

Movement is given the bars 111, 112, 115, 116 by a cam 118, Fig. 3, fixed on a shaft 119 upon which the cam 76 turns freely. This cam operates a bar 120 carrying a roller 121 on one end bearing against the cam, the other end of said bar being pivoted to the free end of a short arm 122 fastened on a cross shaft 123 near the front of the machine. Two upright arms 124, 125, pinned on the shaft 123 are connected by pin and slot joints to the outer sides of the reciprocating bars 112, 116. Rocking freely on the shaft 110 near the center of the machine are two other upright arms 126, 127 that are connected to the bars 111, 115 by similar pin and slot joints. A link 128 extends from each arm 126, 127 forwardly, each link being attached to an arm 129 fast on the shaft 123.

As the cam 118 rotates in the direction of the arrow, the depression therein will be brought opposite the roller 121 whereupon a spring 130 drawing the bar 120 forward, will, through the connections, described, swing the arms 124, 125, 126, 127 in the same direction and move the reciprocating bars 111, 112, 115, 116 into the position indicated by dotted lines in Figs. 1, 3 and 4, whereupon the pawls 117 engage behind a mold on the conveyer belt 107 and carry it off said belt, but the pawls 113, 114 yield and pass the molds to the front thereof. The

cam 118 then draws the bar 120 rearwardly, moving the reciprocating bars in the same direction, causing the pawls 113 to engage and move the filled mold from beneath the opening 39 onto the belt 106, and the pawls 114 to bring an empty mold to filling position. The empty molds are transferred from the discharging mechanism into position to be engaged by the pawls 114 by mechanism which will be hereinafter set forth.

After the filled mold has been placed on the conveyer belt 106, the latter is moved a short distance and then stops, the distance moved being substantially the length from front to rear of the foot pieces 82 on the bottom of the mold. The means for moving the belts will be described later.

With each intermittent movement of the belt 106 a mold is discharged from its rear end onto a platform 131 against a stop rail 135 on the end of the same across which platform the mold is transferred to a point in line with belt 107 where through the longitudinal reciprocation of horizontal bars 132 bearing pawls 133 similar to the bars and pawls at the other end of the belt and connected thereto by rods 134, a mold is moved onto rear end of belt 107 simultaneously with the removal of one from its forward end. Each mold as it is removed from the belt 107 is carried by the pawls 117 against a rib 136 on the front of the table 22 which stops the mold over a discharge opening 137 in the table, see Fig. 2. Above the opening and movable vertically to and from the same is an ejecting plunger 138 arranged to enter the mold, strike the inclined edges to release the latches, and then push its contents through the discharge opening. The plunger 138 is affixed on the lower end of a slide bar 139 movable in a guide 140 fastened on the standard 24 and actuated by an arm 141 having a pin and slot connection at its free end with said slide bar. The arm 141 is part of a lever having a short arm 143, and is mounted on a rock-shaft 142 extending across the machine near the upper end of the standards 22, 23. To this second arm 143 is pivotally attached a cam actuated bar 144 extending downward to and operated by a cam 145 loosely mounted on the shaft 119. The cam moves intermittently and ejects at each movement, a pressed and finished plug and a separating plate which fall through the opening 137 upon a shelf 146 that projects a short distance beyond the opening 137 toward an adjacent inclined chute 147 directed downward to a transverse delivery belt 148 leading away from the machine. A soft pad 138<sup>a</sup> is fastened on the top of plunger 138 for wiping out the mold simultaneously with the ejection of the plugs therefrom.

Below and just behind a short channel

149 projecting down from the discharge opening 137 is an ejector plate 150 that pushes the plugs from the shelf onto the chute 147. The plate 150 is fastened on a strip 151 having a depending vertical portion 152 at its right side to which is connected an arm 153 on a short shaft 154 near the floor that is rocked by means of a cam 155 fast on the shaft 50 actuating a cam bar 156 connected to a second arm 157 on the shaft 154.

It is desirable that the separating plates B be otherwise disposed of than discharging them on the delivery belt with the finished plugs and, therefore, one or more electro magnets 158 are fixed above the path of movement of the ejected plugs and separating plates on the upper side of the plugs. The poles of the magnets are close to the passing plates and attract said plates, which are preferably made of tinned iron, and hold them while the plugs continue toward the belt 148. As soon as the plugs pass and the ejector returns to position, the electric circuit through the magnets is broken, permitting the plates to drop in front of the shelf and fall into a tapering channel 159 by which they are guided to a collector 160 below the conveyer belt 148. Should a separating plate adhere to the bottom of a plug from any cause and lie between the plug and the shelf, a second electro-magnet or series of magnets 161 below the shelf are provided to hold said plate. The magnets 161 are mounted on a pivot 162 to swing from an inclined position below the shelf 146 into position where the faces of their poles will be in a plane with the top of the shelf and thus serve as supports for the ejected plugs. The magnets are swung into line with the shelf at each forward movement of the ejector 150 by a cam 163 on the forward edge of the vertical portion 152 of the strip 151 fastened on the ejector. This cam acts on an arm 164 projecting from the magnet pivot 162, as shown, to swing the magnets into line with the shelf and away therefrom at each operation of the ejector. The inclined position of the magnets 161 is such that all separating plates collected by them are turned sufficiently to cause them to fall through the channel 159 in an edgewise direction, and furthermore, plates retained by the upper magnets 158 when dropped, fall on the poles of the magnets 161 and are turned to insure their descent through the channel edgewise.

The collector 160 comprises a trough 165 below the channel extending horizontally in a forward direction from the front of the machine, but having an inclination laterally, as in Fig. 4. The plates are pushed against a sliding block 166 in the trough as they fall from the channel by a pusher 167 that is moved back and forth by an arm 168 on the

rock shaft 154 connected by a link 169 with a sliding stem on the pusher. The two magnets or groups of magnets 158, 161, are in the same electrical circuit that may be opened and closed by the movement of the swinging magnets 161, or in any other suitable and well known manner.

The transfer mechanism for shifting the molds 40 from one conveyer belt to the other at the front and rear ends of said belts comprise two transversely reciprocating horizontal bars, see Fig. 1, one 170 at the front of the table 22 and the other 171 in rear of the platform 131, both bars being above the plane of the conveyer belts. These reciprocating transfer bars 170, 171 each move in suitable supports and have racks 172, 173, respectively, on their under sides with which gear wheels 174, 175 engage. Fixed to the respective gear wheels are pinions 176, 177 rotated by vertically movable racks 178, 179. The rack 178 is operated by an arm 180 projecting forwardly from a sleeve 181 turning loosely on the shaft 123, said arm having a slot on its free end with which a pin on the rack bar 178 engages. An arm 182 similar to arm 180 moves the rear rack bar 179. An arm 183 projects downward from the loose sleeve 181 and is connected by a rod 184 to an upwardly projecting arm 185 fixed on the arm 182. By this means the two vertical rack bars 178, 179, are moved in unison, as also are the two transfer bars 170, 171, the latter bars however move in opposite directions, this result being obtained by engaging the vertical rack bars with opposite sides of the pinions 176, 177. A cam 186 operates the arms 180, 182 through a cam bar 187 on which is a roller within the cam slot, said bar being connected to an arm 188 projecting from the sleeve 181.

A finger 189 is fastened on the transfer bar 170 and extends rearwardly over the table 22 in position to engage the right end of each mold when against the rib 136 on the front of the table. A like finger 190 on the transfer bar 171 lies to the left of the molds when abutting the rail 135 on the rear of platform 131. At the proper time, the cam 186 through the mechanism described draws the rack bars 178, 179 downwardly causing the gear wheels 174, 175 to rotate and the transfer bars to reciprocate in opposite directions, whereupon the fingers 189, 190 will each carry a mold across the machine, and leave it in line with a conveyer belt, the finger 189 moving to the left with an empty mold toward the belt 106, while the finger 190 transfers a filled mold in position to be pushed onto belt 107.

The movement of the pressing plunger 31 into and out of a mold during the packing operation may at times cause a displacement of such mold unless means are provided to

hold it stationary. One such means is shown in Figs. 1 and 4 of the drawings and comprises a pair of arms 191, 192, pivoted below the table 22 at 193, 194 and extending up through openings therein on the right and left ends of the filling position of the mold. The upper ends of the levers are forked as at 195 to engage the ends of a mold and hold it against displacement, and are swung into engagement by a cam 196 on the shaft 119 actuating in one direction, a bell crank lever 197, one arm of which is connected by a link 198 to an arm 199 projecting from each forked arm 191, 192. A spring 200 disengages the forked arms from the mold and holds the bell crank lever against the cam.

The mechanisms hereinabove described are given motion through a primary driving shaft 201 extending across the machine in rear of standards 21 and below the table 22 from any convenient source of power, in the embodiment shown, an electric motor 202 is provided, see Figs. 1 and 6, on the shaft of which is a worm 203 driving a worm gear 204 fixed on the shaft 201, on which shaft is also a broad faced pinion 205 in continuous engagement with a spur gear 206 fast on a sleeve 207 free both to rotate and slide on the shaft 50. The ends of the sleeve 207 are each made with a clutch face, one of which couples with the complementary clutch face on a collar 208 fast on the shaft when moved to the left, or with a like face on a sleeve 209 free to rotate on the shaft and provided with a spur gear wheel 210. Fixed on the shaft 50, see Figs. 2 and 5, are the cams 49, 59, and 155, the driving pinion 211 of a step by step or Geneva movement, a small pinion 212, a sprocket wheel 213 and a spiral gear wheel 214. The sprocket wheel 213 drives a chain 215 that extends upward and passes over a sprocket wheel 216 on the crank shaft 26 to drive the same. The pinion 212 meshes with a large spur gear 217 to which is secured a pinion 218 both of which are loose on the shaft 119, said pinion driving another large gear wheel 219 fixed on the shaft 101. This shaft 101 and shaft 102 carry respectively the pulleys or drums 220, 221 around which the conveyer belts, 106, 107 pass and by which they are driven. The shaft 119 is driven by a gear wheel 222 from the gear wheel 210 and turning with said shaft are cams 118 and 186. The other cams 145, 76 and 196 and the large intermittently movable wheel 223 of the Geneva movement are loose on said shaft and move in unison with said wheel 223 when the smaller wheel or pinion 211 rotates.

The several mechanisms operated by and through the cams and gears fast on the shaft 50 are put in motion whenever the clutch on the sleeve 207 is in engagement with the fixed sleeve 208. These mechanisms include the entire machine except the mold transferring means at opposite ends of the conveyer belts 106, 107, which means is operated only when the sliding sleeve 207 engages the sleeve 209 to rotate the shaft 119 and the cams 118, 186 fixed thereon, at which time all the other mechanisms are at rest and remain inactive until the clutch sleeve 207 is shifted.

For the purpose of shifting the sleeve 207 to right and left, a worm 224 is secured on the continuously running driving shaft 201 that revolves in proper time a worm wheel 225 on a stub shaft on one side of which wheel is a cam 226 with a periphery of suitable shape and proportions against which an arm 227 is held by a spring 228. A shifting lever 229 secured on the pivot of the arm 227 has a forked upper end that embraces the sleeve 207 and engages a slot therein. The worm wheel 225 and cam 226 make one complete revolution with each operation of the machine, the cam being so timed that it moves the shifting lever 229 to couple up the transfer mechanism for operation after the plunger 31 has filled one mold and the plunger 138 emptied another.

The spiral gear wheel 214 on the shaft 50 drives a similar gear 230 below the same and at right angles thereto, this second gear meshing with a third gear wheel 231 on a longitudinal shaft 232 that extends toward the front of the machine where a gear wheel 233 thereon drives a gear wheel 234 on the shaft of one of the pulleys or drums over which the finished plug conveyer belt 148 passes.

In the operation of the machine, let it be assumed that the hoppers 28, 29 and 30 are filled respectively with plugs A to be pressed, separating plates B, and pressure plates C, and an empty mold 40 in position below the opening 39 and locked in place by the arms 191, 192. The motor being started, the shaft 201 rotates continuously, the pinion 205 thereon driving the gear wheel 206 on the loose sleeve 207. The clutch on said sleeve engaging the clutch face on the collar 208, rotates the shaft 50 and the sprocket wheel 213, pinions 211, 212, and the several cams secured thereon. The rotation of the pinion 211 causes the wheel 223 of the Geneva movement to rotate intermittently carrying therewith the cams 145, 196 and 76, the latter cam operating the arm 75 and through the connections described advances the slide 72 to push a pressure plate C from the hopper 30 over the opening 39 that it may fall into the bottom of the mold 40. The cam 59 now actuates the bar 60 through which the plates 54, below the hopper 29, are operated to drop a separating plate B upon the rails 58. The pusher 41 and the slide 64 are immediately advanced by the

cams 49 to simultaneously carry a plug A and a plate B from their respective hoppers above the opening 39 and below the plunger 31. By this time the crank 37, driven by the sprocket wheel 213 and chain 215, has brought the plunger 31 downward to push said plug and plate into the mold 40 against the pressure plate C in the bottom thereof. The crank in its downward movement carries the cylinder 34, piston 33 and plunger together until the plunger has forced the plug to the bottom of the mold against the plate and begins to exert pressure thereon, whereupon the plunger and piston are halted in their movement but the cylinder continues. Halting of the plunger forces the piston up the cylinder, compressing the air and spring 92 within the cylinder until a predetermined air pressure has been reached, whereupon the relief valve 97 opens and the pressure on the plug remains constant through the remainder of the stroke. Upon the return movement of the crank these parts are elevated; the plunger leaves the mold and the piston is moved to the bottom of the cylinder by the spring 92, air entering the cylinder above the piston through the check valve 96. With each rotation of the shaft 50 a plug and a separating plate are fed into the mold and pressed by the plunger 31 until the full complement of plugs ten in number, have been placed therein. With each rotation of the shaft 50 to feed a plug and a separating plate, to the mold, the pinion 211 makes one revolution and turns the wheel 223 of the Geneva movement one step carrying the cams 145, 76 and 196 with it, as described. Just before the last step has been made, the cam 76 will have been brought into such position that the depression 79 therein will aline with the lever 75 which being drawn into said depression by the spring 77, will cause the slide 72 to feed a pressure plate above the last plug and its separating plate so that the three will be pushed together by the plunger into the mold 40, said pressure plate being forced downward sufficiently to be held by the hooked ends 89 of the latches on the front and rear walls of the mold.

After a mold has been filled and the plunger drawn therefrom, the sleeve 207 is moved to the right by the worm wheel 225 driven by worm 224, and cam 226 fixed to worm wheel actuating the shifting lever 229. This movement couples the gear wheel 206 to the sleeve 209 and disengages all the mechanism heretofore moved through the collar 208. Rotation of the sleeve 209 revolves the shaft 119 through the gears 210, 222 and the cams 118 and 186 fixed thereon, the former cam operating the mechanism described to move the longitudinal reciprocating bars 111, 112 to the dotted position shown in Fig. 1 and back again. The annular bars 114, 115 move in unison therewith. This movement of the bars 111, 112, causes the fingers 113 thereon to withdraw the filled mold from beneath the opening 39 and place it upon the conveyer from beneath the opening 39 and place it upon the conveyer belt 106. By the same movement of the bars 111, 112, the fingers 114 move an empty mold into position beneath the opening 39, these to be filled and in turn placed upon a conveyer belt. After each mold has been placed upon the belt 106 the latter is moved a short distance, just far enough for another mold to be moved thereonto. The molds are filled and pushed upon the belt, and when the latter is filled the most advanced mold on the belt is pushed by the moving belt upon the platform 131 with every movement of said belt. Each mold after passing onto the platform must be transferred to the belt 107 before another movement of belt 106. Just before each forward movement of the bars 111, 112, 115, 116, the forward transfer bar 170 is moved to the left to carry an empty mold from the discharge mechanism into position to be engaged by the pawls 114, and the rear transfer bar 171 moves simultaneously to the right to carry a mold from the belt 106 into position in front of pawls 133 back of the rear end of belt 107 to be pushed onto said belt. The conveyer belt 106 travels slowly rearwardly with the filled molds thereon, and these molds are transferred, one at a time, to the belt 107 and brought back to the machine by said belt. At each forward movement of the longitudinally reciprocating bars 111, 112, 115 and 116 the bars 115, 116 only operate, the pawls 117 thereon push a filled mold above the discharge opening 137 and beneath the plunger 138. Simultaneously with the movement of the bars 115, 116, the rear bars 132 advance with their pawls 133 to place a mold on the rear end of belt 107. The bars all move rearwardly at the same time, the bars 111, 112 only being active, their pawls 113, 114 carrying respectively a filled mold to the belt 106 and an empty mold to filling position below the opening 39. The cam 145 that operates the discharge plunger 138 being secured on the intermittently moving wheel 223, the plunger is moved at each impulse only far enough to discharge one plug and separating plate, the friction of the plugs on the side of the mold preventing the others falling. Each plug and separating plate falls upon the shelf 146 from which they are carried by the pusher 150 between the electro-magnets 158, 161, which remove the plate from the plug and permit the latter to be deposited on the conveyer belt 148. Upon the return of the pusher 150, the cir-

cuit through the magnets is broken and the separating plates drop into the channel 159 and from thence pass into the trough 165 of the collector 160. The pressure plates

5 C may also fall into the collector 160.

I do not wish to be understood as limiting myself to the various specific mechanisms, herein shown and described for imparting movements to the different parts of the machine as obviously other mechanisms may be substituted for those shown, without departing from the spirit of the invention, the showing here being simply by way of example.

15 What I claim is:—

1. In a plug tobacco pressing and finishing machine, a mold-box, means for feeding plugs and separating finishing plates thereinto, to form a pack of plugs, means for feeding in pressure plates so as to abut the end plugs of the pack, means for compressing the plugs in the mold box after a predetermined number of plugs have been deposited therein, and means for latching said pressure plates to maintain the compression of said pack.

2. In a plug tobacco pressing and finishing machine, a movable mold box open at both ends, means for feeding plugs into said box and for feeding a pair of end pressure plates into the box so as to form a pack of plugs between said pressure plates in said box, means for compressing the plugs in the mold box after a predetermined number of plugs have been fed thereinto, and means for latching the said plates in the mold box respectively at the opposite ends of the mold box to maintain the plugs under compression.

3. In a plug tobacco pressing and finishing machine, a hopper having a receiving point for receiving plugs, and having a discharge outlet for the plugs to be pressed, a mold box movable beneath said hopper, means for feeding plugs from the hopper into the mold box, a plunger having yielding means, and reciprocating means for imparting pressure through said yielding means to said plunger for compressing the plugs in the mold box after a number of plugs have been deposited therein, said yielding means permitting said reciprocating means to continue its downward movement in each stroke after the plunger has been stopped by the tobacco within the mold.

4. In a plug tobacco pressing and finishing machine, a hopper for receiving plugs to be pressed, a plurality of movable mold-boxes, means for moving the mold-boxes successively beneath the hopper, means for feeding plugs into the said mold-boxes, means for compressing the plugs in the mold-boxes in succession after a predeter-

mined number of plugs have been fed thereinto, and means carried by each mold-box for maintaining the plugs therein under compression.

5. In a plug tobacco pressing and finishing machine, a hopper for receiving the plugs to be pressed, a hopper for containing separating plates to be placed between said plugs, a plurality of movable mold boxes, means for feeding plugs and separating plates to the mold-boxes successively, means for compressing the plugs in each mold box after a predetermined number of plugs and plates have been fed thereinto, means carried by each mold-box for maintaining the plugs under compression, and means for removing the mold boxes successively away from said hopper.

6. In a plug tobacco pressing and finishing machine, a mold box, means for successively and simultaneously feeding a plug and a separating finishing plate into the mold box, a plunger having yielding means, and reciprocating means for applying pressure through said yielding means to said plunger to press each plug upon entering the mold box, said yielding means permitting said reciprocating means to continue its downward movement after the downward movement of the plunger is stopped by the tobacco.

7. In a plug tobacco pressing and finishing machine, a mold box, means for successively feeding a plug and a separating finishing plate into the mold box, a plunger having yielding means, and reciprocating means for applying pressure through said yielding means to said plunger to press each plug upon entering the mold box and at the same time the previously pressed plugs within the mold box, said yielding means permitting said reciprocating means to continue its downward movement after the downward movement of the plunger is stopped by the tobacco.

8. In a plug tobacco pressing and finishing machine, a mold-box, means for successively feeding plugs and separating finishing plates thereinto to form a pack within the mold-box, means for feeding a pressing plate into said mold-box before and after a predetermined number of plugs have been fed thereinto, and means for pressing each plug upon entering the mold-box against the pack of plugs and simultaneously compressing the pack of plugs.

9. In a plug tobacco pressing and finishing machine, a mold-box, means for feeding plugs and separating finishing plates thereinto to form a pack within the mold-box, means for feeding a pressing plate into said mold-box before and after a predetermined number of plugs have been fed thereinto, means for pressing each plug

upon entering the mold-box against the pack of plugs and simultaneously compressing the pack of plugs, and means for maintaining the pressure on said plugs.

5 10. In a plug tobacco pressing and finishing machine, a hopper for plugs to be pressed, a plunger, a mold-box movable beneath said plunger, automatic means for feeding plugs singly from the hopper be-  
10 neath the plunger, and means for operating said plunger to apply an adjustable maximum pressure to each plug upon entering the box.

15 11. In a plug tobacco pressing and finishing machine, a hopper for plugs to be pressed, a hopper for separating plates to be placed between said plugs, a plunger, a mold-box movable beneath said plunger, means for simultaneously feeding plugs and  
20 plates singly from said hoppers beneath the plunger, and means for operating said plunger to apply an adjustable maximum pressure to each plug upon entering the box, and at the same time to the previously  
25 pressed plugs therein.

12. In a plug tobacco pressing and finishing machine, a hopper for plugs to be pressed, a plunger, a mold-box movable beneath said plunger, means for feeding plugs  
30 singly from the hopper beneath the plunger, means for operating said plunger to apply an adjustable maximum pressure to each plug upon entering the box, and to the previously pressed plugs therein, and automatic  
35 means on the mold-box for holding said plugs under compression.

13. In a plug tobacco pressing and finishing machine, a hopper for plugs to be pressed, a hopper for containing separating  
40 finishing plates, a plunger, a mold-box movable beneath said plunger, means for feeding plugs and plates singly from said hopper beneath said plunger, means for operating said plunger to apply a maximum pres-  
45 sure simultaneously to each plug upon entering the mold box and to the previously pressed plugs therein, and automatic means on the mold box for maintaining said plugs under compression.

50 14. In a plug tobacco pressing and finishing machine, a hopper for plugs to be pressed, a hopper for separating finishing plates, a hopper for pressure plates, a plunger, a mold-box movable beneath said plunger,  
55 means for simultaneously feeding a predetermined number of plugs and separating plates singly from their hoppers into the mold-box, means for feeding a pressure plate into the mold-box before and after the  
60 predetermined number of plugs have been fed therinto, means for operating said plunger to apply a maximum pressure to each of said plugs upon entering the box and to the previously pressed plugs there-

in, and automatic means on the mold-box 65 for locking said pressure plates against movement to maintain said plugs under compression.

15. In a plug tobacco pressing and finishing machine, a mold-box, means for feeding 70 a predetermined number of plugs singly therinto, means for applying pressure to each plug upon entering said mold-box, means for maintaining said plugs under pressure within said mold-box after the  
75 same has been filled, and automatic means for removing a filled mold-box and inserting in its place one to be filled.

16. In a plug tobacco pressing and finishing machine, a mold-box, automatic means 80 for feeding a predetermined number of plugs singly therinto, means for simultaneously applying pressure to each plug upon entering said mold-box and to the previously pressed plugs therein, and adjustable  
85 means for preventing the pressure exceeding a predetermined point.

17. In a plug tobacco pressing and finishing machine, a hopper for plugs to be pressed, a hopper for separating plates, a  
90 pressing plunger, a mold-box movable beneath said plunger, means for feeding a predetermined number of plugs and plates beneath said plunger one of each simultaneously, means for operating said plunger to  
95 push a plug and a plate into the mold-box and apply pressure to each plug as it enters said box and to the previously pressed plugs therein, and means to maintain said plugs under pressure in the mold-box. 100

18. In a plug tobacco pressing and finishing machine, a mold-box, means for feeding a predetermined number of plugs singly therinto, means for discharging said plugs from the mold-box and transporting means  
105 for carrying the mold box from the filling means to the discharging means.

19. In a plug tobacco pressing and finishing machine, a plurality of mold-boxes, means for feeding a predetermined number of  
110 plugs singly into each mold-box to fill the same, means for discharging said plugs from one of the mold-boxes coincidentally with the filling of another of the mold-boxes, transporting means for carrying the mold boxes  
115 from the filling means to the discharging means, and means for returning the empty mold-box to the filling position.

20. In a plug tobacco pressing and finishing machine, a mold-box, means for feeding 120 a predetermined number of plugs singly thereto, means for feeding a separating finishing plate into the mold-box before and after the predetermined number of plugs have been fed therinto, means for operating said plunger to apply a maximum pressure to each plug upon entering  
125 said mold-box, means for maintaining said plugs under pressure, automatic means for removing a filled mold-box and inserting in

its place a box to be filled, and means for separating the plates from the plugs after they are discharged from the mold-box.

21. In a plug tobacco pressing and finishing machine, a mold-box, means for feeding a predetermined number of plugs singly thereinto, means for feeding a separating finishing plate above each plug simultaneously with the feeding of said plug, means for applying pressure to each plug upon entering said mold-box, means for maintaining said plugs under pressure, automatic means for removing a filled mold-box and inserting in its place a box to be filled, and electro magnetic means for separating the plates from the plugs, after they are discharged from the mold-box.

22. In a plug tobacco pressing and finishing machine, a plurality of mold-boxes, automatic means for feeding a predetermined number of plugs singly into each mold-box to fill the same, means for discharging said plugs from one of the mold-boxes coincidentally with the filling of another mold-box, conveying means for transporting the filled mold boxes from the filling means, other conveying means for transporting said mold-boxes to the discharging means, means for transferring the mold boxes from the outgoing to the incoming conveyer, and means for transporting the empty mold boxes into filling position.

23. In a plug tobacco pressing and finishing machine, a mold-box, means for feeding a predetermined number of plugs singly thereinto, means for discharging said plugs from the mold box, conveying means for slowly transporting mold boxes from the filling position to the discharge position, the time length of said conveying means being sufficient for the compressed plugs to set, and means for returning the empty mold boxes to filling position.

24. In a plug tobacco pressing and finishing machine, a mold box, means for individually feeding plugs alternating with finishing plates into said mold box, a yielding plunger and means for actuating the same to descend after each plug is inserted and yieldingly press each plug, and all the plugs in the mold box after a predetermined number of plugs and plates have been deposited therein.

25. In a plug tobacco pressing and finishing machine, a movable mold-box, means for feeding plugs thereinto, means for compressing the plugs in the mold box after a predetermined number of plugs have been fed thereinto, means for advancing the mold box full of plugs forward from the plug receiving position, and means for maintaining the plugs under compression in the mold-box.

26. In a plug tobacco pressing and finish-

ing machine, a hopper for receiving plugs to be pressed, a mold-box movable beneath said hopper, means for feeding plugs from the hopper in position to be deposited in the mold-box, means for supporting the plugs above the mold box, and means for compressing the plugs in the mold box after a predetermined number of plugs have been deposited therein.

27. In a plug tobacco pressing and finishing machine, a hopper for receiving plugs to be pressed, a mold-box movable beneath said hopper, means for feeding plugs from the hopper in position to be deposited in the mold-box, means for supporting the plugs above the mold box, and a yielding plunger after a predetermined number of plugs have been deposited therein.

28. In a plug tobacco pressing and finishing machine, a hopper for receiving plugs to be pressed, a hopper for containing separating plates to be placed between said plugs, a mold-box, separate means for feeding plugs and separating plates to the mold-box, means for compressing the plugs in the mold-box after a predetermined number of plugs and plates have been fed thereinto, and means for maintaining the plugs under compression.

29. In a plug tobacco pressing and finishing machine, a mold-box, means for successively feeding individual plugs and separating finishing plates into the mold box, and a reciprocating plunger having a spring, and means for imparting pressure to said plunger through said spring to force said plunger down to apply a preliminary pressure to each plug upon entering the mold box, said spring permitting the continued compressing movement of said last named means after the downward movement of said plunger is stopped by the tobacco.

30. In a plug tobacco pressing and finishing machine, a mold-box having open ends, means for successively feeding individual plugs and separate finishing plates thereinto, means for feeding a pressing plate into the bottom and top of the mold-box before and after a predetermined number of plugs have been fed thereinto, and means for applying pressure to each plug upon entering the mold-box.

31. In a plug tobacco pressing and finishing machine, a mold-box having open ends, means for simultaneously feeding plugs and separating finishing plates thereinto, means for feeding a pressing plate into the bottom and top of said mold-box before and after a predetermined number of plugs have been fed therein, means for applying pressure to each plug upon entering the mold box and to the previously pressed

plugs within said box, means carried by the mold-box for maintaining the pressure on said plugs, and means for guiding the mold-box away after it is filled.

5 32. In a plug tobacco pressing and finishing machine, a hopper for plugs to be pressed, a yielding plunger, a mold-box movable beneath said plunger, automatic means for feeding plugs singly from the  
10 hopper beneath the plunger, and means for operating said plunger to apply an adjustable maximum pressure to each plug upon entering the box.

15 33. In a plug tobacco pressing and finishing machine, a hopper for plugs to be pressed, a hopper for separating plates to be placed between said plugs, a yielding plunger, a mold-box movable beneath said  
20 plunger, means for simultaneously feeding plugs and plates singly from said hopper beneath the plunger, means for supporting the plugs and plates in position above the mold box, and means for operating said  
25 plunger to apply an adjustable maximum pressure to each plug upon entering the mold-box.

34. In a plug tobacco pressing and finishing machine, a hopper for plugs to be pressed, a plunger, a mold-box movable beneath said plunger, means for feeding plugs  
30 singly from the hopper beneath the plunger, automatic means for temporarily supporting the plugs above the mold box, and means for operating said plunger to apply  
35 an adjustable maximum pressure to each plug upon entering the mold box.

35. In a plug tobacco pressing and finishing machine, a hopper for plugs to be pressed, a hopper for separating finishing  
40 plates, a hopper for pressure plates, a plunger, a mold-box movable beneath said plunger, said mold-box having open ends, means for feeding a predetermined number of plugs and separating plates from their  
45 hoppers into the mold-box, means for feeding a pressure plate into the top and bottom of the mold box before and after the predetermined number of plugs have been fed thereinto, means for operating said plunger  
50 to apply a maximum pressure to each of said plugs upon entering the mold box and to the previously pressed plugs therein, and automatic means on the mold-box for locking said pressure plates against movement  
55 to maintain said plugs under compression.

36. In a plug tobacco pressing and finishing machine, a mold-box, means for feeding a predetermined number of plugs singly  
60 thereinto, means for maintaining the plugs under compression for a predetermined period, means for discharging said plugs from the mold-box, and transporting means for carrying the mold-box from the the filling means to the discharging means.  
65

37. In a plug tobacco pressing and finish-

ing means, a mold-box, means for feeding a predetermined number of plugs thereinto, means for discharging said plugs from the mold-box, transporting means for carrying  
70 the mold boxes from the feeding means to the discharging means, and means for returning the empty mold-boxes to the filling position.

38. In a plug tobacco pressing and finishing machine, a mold-box, means for feeding  
75 a predetermined number of plugs thereinto, means for discharging said plugs from the mold box, conveying means movable in one direction for transporting the filled mold boxes from the filling means, other  
80 conveying means movable in an opposite direction for transporting said mold-boxes to the discharging means, means for transporting the mold boxes from the outgoing to the incoming conveyer, and means for  
85 transporting the empty mold boxes into filling position.

39. In a plug tobacco pressing and finishing machine, a mold box, means for individually and successively feeding a predetermined number of plugs into the mold  
90 box, means for feeding a separating finishing plate simultaneously with each plug, a plunger, a spring associated with said plunger, and means for applying pressure  
95 through said spring to said plunger for yieldingly compressing each plug as fed into said mold box, said spring permitting the continued compressing movement of said last named means after the downward movement of said plunger is stopped by the tobacco.  
100

40. In a plug tobacco pressing and finishing machine, a plurality of mold-boxes, means for feeding a predetermined number  
105 of plugs successively thereinto, means for feeding a separating finishing plate simultaneously with each plug, means for compressing each plug as fed into the mold-box being filled and all the plugs after the predetermined number have been fed thereinto, means carried by each mold-box for maintaining the plugs under compression  
110 and means for guiding away the mold-boxes after being filled.  
115

41. In a plug tobacco pressing and finishing machine, a mold box, means for feeding  
120 plugs to be pressed into said mold box, automatic means for actuating said feeding means to cause a predetermined number of plugs to be fed successively, a plunger, a spring associated therewith, and means for reciprocating said plunger and applying pressure to said plunger through said spring  
125 to press each plug after entering the mold box and further pressing the previously fed plugs, said spring permitting the continued compressing movement of said last named means after the downward movement of said plunger is stopped by the tobacco.  
130

42. In a plug tobacco pressing and finishing machine, a mold box, automatic means for individually feeding a predetermined number of plugs to be pressed and separating finishing plates thereinto, means for actuating said feeding means to cause each plug and a plate to be fed simultaneously, a plunger, a spring associated with said plunger, and means for imparting pressure to said plunger through said spring for pressing each plug after entering the mold box and further pressing the previously fed plugs, said spring permitting the continued compressing movement of said last named means after the downward movement of said plunger is stopped by the tobacco. 70
43. In a plug tobacco pressing and finishing machine, a mold box, a hopper for the plugs to be pressed, a hopper for the separating finishing plates, means for feeding plugs to said mold box, other means for feeding a separating plate simultaneously with and upon each of said plugs, means for actuating said feeding means to feed automatically a predetermined number of plugs and plates into said mold box, a plunger, a yielding member associated with said plunger, and means for imparting pressure through said plunger to said yielding member and reciprocating said plunger to press the plugs in said mold box and to press each plug as it is fed into said mold box, said spring permitting the continued compressing movement of said last named means after the downward movement of said plunger is stopped by the tobacco. 75
44. In a plug tobacco pressing and finishing machine, a plurality of mold boxes, a hopper for the plugs to be pressed, a hopper for the separating finishing plates, means for feeding plugs to the mold boxes in succession, means for feeding a separating plate into the mold boxes simultaneously with and upon each of said plugs, means for controlling said feeding means to feed a predetermined number of plugs and plates into said mold boxes, a plunger, a spring associated therewith, and means for imparting pressure through said spring to said plunger for pressing the plugs in said mold boxes, said spring permitting the continued compressing movement of said last named means after the downward movement of said plunger is stopped by the tobacco and means carried by said mold boxes for holding said plugs under pressure. 80
45. In a plug tobacco pressing and finishing machine, a mold-box, a hopper for plugs to be pressed, a hopper for separating finishing plates, a hopper for pressing plates, means for feeding plugs to said mold-box, means for feeding a separating plate simultaneously with and upon each plug, means for feeding a pressing plate to said mold-box below and above the plugs therein, means for actuating the feeding means for the plugs and the separating plates to feed a predetermined number of said plugs and plates into said mold-box, means for pressing each plug as it enters the mold-box, and means on said mold-box to lock said pressing plates therein to hold the plugs under pressure. 85
46. In a plug tobacco pressing and finishing machine, a mold-box, means for feeding a predetermined number of plugs and separating plates thereinto one of each at a time, means for applying pressure to each plug upon entering the mold-box and to the previously pressed plugs, means for maintaining said plugs under compression in said mold-box, a slowly moving runway, means for discharging the plugs and plates from the box, and means for transporting the filled mold-boxes onto the runway, from the runway to the discharge means and empty mold-boxes into position to be filled. 90
47. In a plug tobacco pressing and finishing machine, a mold-box, means for feeding a predetermined number of plugs and separating plates thereinto one of each at a time, means for applying pressure to each plug upon entering the mold-box and to the previously pressed plugs, means for maintaining said plugs under compression in said mold-box, a slowly moving runway, means for discharging the plugs and plates from the box, means for transporting the filled mold-boxes onto the runway, from the runway to the discharge means and empty mold-boxes into position to be filled, and means for separating the plates from the plugs. 95
48. In a plug tobacco pressing and finishing machine, a mold-box, means for feeding a predetermined number of plugs and separating plates thereinto one of each at a time, means for applying pressure to each plug upon entering the mold-box and to the previously pressed plugs, means for maintaining said plugs under compression in said mold-box, a slowly moving runway, means for discharging the plugs and plates from the box, means for transporting the filled mold-boxes onto the runway, from the runway to the discharge means and empty mold-boxes into position to be filled, and magneto-electric means for separating the plates from the plugs. 100
49. In a plug tobacco pressing and finishing machine, a mold-box, means for feeding thereinto one at a time a predetermined number of plugs to be pressed, means for simultaneously applying pressure to each plug upon entering said mold-box and to the previously pressed plugs therein, and automatic means for preventing the pressure exceeding a predetermined amount. 105
50. In a plug tobacco pressing and finishing machine, a mold-box, means for feeding 110

thereinto one at a time a predetermined number of plugs to be pressed, means for applying pressure to each plug as it enters said mold-box, means for retaining the plugs under compression, means for discharging pressed plugs from said mold-box one at a time, a runway, and means for transporting filled mold-boxes to said runway and from said runway to the discharging means.

51. In a plug tobacco pressing and finishing machine, a mold-box, means for feeding thereinto plugs to be pressed and separating finishing plates, means for simultaneously pressing each plug as it enters said mold-box and the previously pressed plugs therein, means for retaining said plugs under compression in said mold-box, means for discharging pressed plugs from the mold boxes, a runway comprising an outgoing and a returning conveyer belt, means for moving filled mold-boxes upon the outgoing conveyer and placing other boxes in position to be filled, means for transferring said mold-boxes from the outgoing to the incoming conveyer, means for removing said mold-boxes from the incoming conveyer to the discharging mechanism, and means for transferring the empty mold boxes from the discharging mechanism into position to be carried beneath the filling means.

52. A mold-box for pressing and finishing plug tobacco, comprising a bodily movable receptacle having open ends, pressure plates forming parts of the receptacle for closing the open ends thereof when said receptacle is filled with tobacco under compression, and hook-shaped rigid arms carried by the receptacle for retaining the said pressure plates in position against pressure of the tobacco in the receptacle.

53. A mold-box adapted to be movably associated with a machine for pressing and finishing plug tobacco, comprising a bodily movable receptacle having open ends, pressure plates forming parts of the receptacle for closing the ends thereof when the receptacle is filled with tobacco under compression, rigid arms pivoted to opposite walls of the receptacle, each arm having a hook-shaped end adapted to engage and retain in position its associated pressure plate against the pressure exerted by the tobacco, and means acting upon the arms normally tending to hold their hooked ends in engagement with the plates.

54. For use in connection with a plug tobacco pressing and finishing machine, a bodily movable mold-box comprising a receptacle open at both ends adapted to receive a plurality of superposed plugs under compression, pressure plates movable completely through and forming parts of the receptacle for closing the ends thereof, and means carried by the receptacle for removably holding the said pressure plates in po-

sition and the plugs under compression therebetween, whereby the mold-box may be moved about while maintaining the tobacco therein under compression.

55. A portable mold-box for use in connection with a machine for pressing and finishing plug tobacco, comprising a bodily movable receptacle having open ends, pressure plates carried by and forming parts of the receptacle for closing the opposite ends thereof, a pair of interconnected rigid arms pivoted on each of two opposite sides of the receptacle, each arm having a hook-shaped end adapted to engage and retain its associated pressure plate in position to retain the plugs under compression, and yielding means acting upon the said pivoted arms for normally holding said hook-shaped ends in engagement with the pressure plates.

56. A mold-box adapted to be removably associated with a machine for pressing and finishing plug tobacco comprising a bodily movable receptacle having open ends, a pressure plate for closing each end of said receptacle, rigid arms arranged in pairs having pivotal connections on the side walls of said receptacle and having overlapping adjacent ends, each arm having a hook-shaped end adapted to engage and retain its corresponding pressure plate in position to retain the plugs under pressure in the receptacle, and yielding means located at the said overlapping ends and acting thereupon to maintain said hook-shaped ends in engagement with said plates.

57. In a plug tobacco pressing and finishing machine, a plurality of independent bodily movable mold-boxes, means for placing therein a pack consisting of a predetermined number of plugs with separating plates therebetween and with pressure plates at the ends thereof, means for forcing the pressure plates toward each other to place the entire pack under compression, means carried by the mold-boxes and movable therewith for engaging the pressure plates to maintain the plugs under compression when the mold-boxes are moved away from the pressing means, and means for guiding the said mold-boxes to a place of rest while the pressure on the tobacco therein is maintained.

58. A mold-box of the class described comprising a bodily movable receptacle having open ends, pressure plates forming parts of the receptacle for closing each end thereof, two pairs of rigid arms pivotally mounted upon each of two opposite walls of the receptacle with the adjacent ends of each pair of arms overlapping and pivotally connected, and the free end of each arm having a hook, and yielding means interposed between a wall of the receptacle and the point of pivotal connection between each pair of arms for normally retaining the hooked end

of the arms in engagement with its associated pressure plate.

5 59. A mold-box adapted to be movably associated with a machine for pressing and finishing plug tobacco comprising a bodily  
movable receptacle having open ends, pressure plates forming parts of the receptacle for closing the ends thereof when the receptacle is filled with tobacco under compression, movably mounted members for engaging the pressure plate at one end of the  
10 receptacle, other movably mounted members movable in unison with said first members

having ends adapted to engage the pressure plate near the other end of the receptacle, 15 the walls of said receptacles having openings through which said last named members project to engage the pressure plate.

In testimony whereof I have hereunto set my hand in presence of two subscribing witnesses. 20

ROBERT B. DULA.

Witnesses:

E. H. BICKERTON,  
J. GRANVILLE MEYERS.

Copies of this patent may be obtained for five cents each, by addressing the "Commissioner of Patents, Washington, D. C."