

(Model.)

T. HALL.  
DRILL GRINDER.

No. 497,095.

Patented May 9, 1893.

Fig. 1.

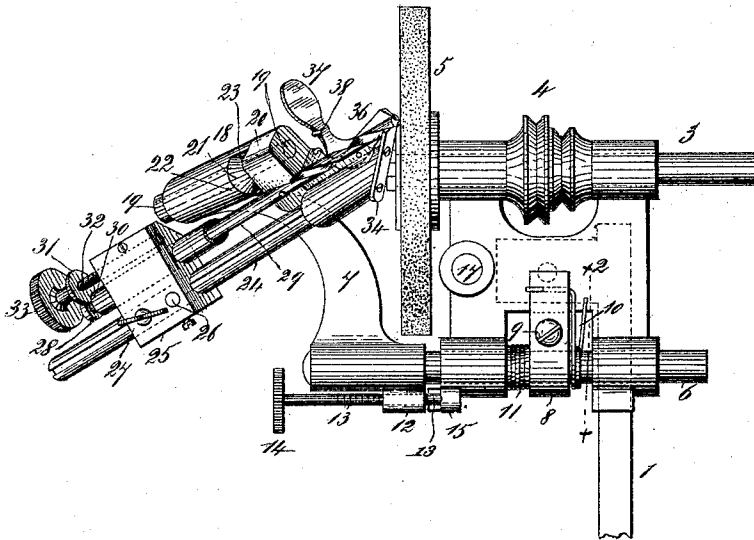

Fig. 2.

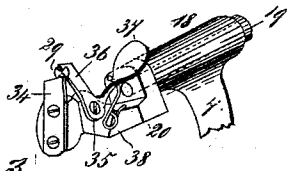
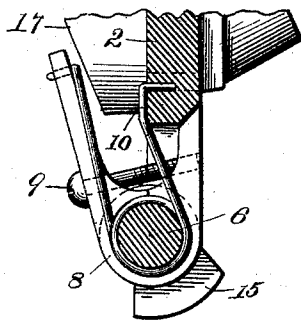

Fig. 3.



Witnesses:  
John Buckler,  
Isabel Chester

Inventor:  
Thos. Hall.

By a. m. Pierce,  
Attorney.

# UNITED STATES PATENT OFFICE.

THOMAS HALL, OF NEW YORK, N. Y.

## DRILL-GRINDER.

SPECIFICATION forming part of Letters Patent No. 497,095, dated May 9, 1893.

Application filed January 9, 1892. Serial No. 417,454. (Model.)

*To all whom it may concern:*

Be it known that I, THOMAS HALL, a citizen of the United States, and a resident of the city, county, and State of New York, have invented a new and useful Improvement in Drill-Grinders, of which the following is a specification.

My invention relates especially to mechanism employed for holding twist drills in proper position for grinding the same, and has for its object the provision of a holder whereby any size of drill may be instantly placed in proper position and securely held therein, while being ground, and whereby both faces may be accurately given the same pitch and angle.

To attain the desired end, my invention consists essentially in a drill holder, having a stationary tongue, and a movable finger, adapted and arranged to grasp and hold drills of all sizes, the proper pitch and angle being automatically given to the various drills.

My invention further consists in a supporting frame for a grinding wheel or stone, said frame being provided with a movable support for an arm whereon the drill-holding and regulating mechanism is mounted; and my invention also involves certain other novel and useful combinations or arrangements of parts, and peculiarities of construction and operation, all of which will be hereinafter first fully described, and then pointed out in the claims.

In the accompanying drawings, Figure 1 is a front elevation of my improved drill grinder and holder, and Fig. 2 is a face view of the holder with a drill therein, separated from the remaining mechanism. Fig. 3 is a vertical, sectional view of line X—X of Fig. 1.

Similar numerals of reference, wherever they occur, indicate corresponding parts in all the figures.

1 is a standard, fixed to any approved holding frame, the shape of the rear portion thereof being indicated by the dotted line in Fig. 1.

2 is an H shaped casting secured to the standard 1 by a screw, also indicated in dotted lines in Fig. 1. The H shaped piece forms at top the bearings for a spindle 3, whereon are mounted a pulley or pulleys 4, and an emery wheel or stone 5; and at bottom the

bearings for a movable shaft 6 whereon a supporting arm or bracket 7 is secured.

8 is a finger extending around the shaft 6, being held firmly in place by a screw 9.

10 is a spring which normally throws the finger 8 outward, the limit of movement being obtained by the striking of the rear portion of said finger at the back of shaft 6 against the H shaped piece.

11 is a spring coiled around shaft 6, exerting a pressure to move said shaft to the right. Mounted in a screw-threaded bearing 12 at the bottom of bracket 7, is a screw 13 provided with a manipulating button 14. The inner extremity of this screw 13 strikes against a stud 15, at the base of the H shaped piece or frame. By withdrawing the screw, the spring 11 will move shaft 6 to the right, the counter movement being obtained by turning the screw 13 inward so as to bear against the stud 15. By this arrangement the bracket 7 may be made to approach and recede from the wheel 5, the limit of movement being regulated by means of the screw 13.

17 is an arm projecting at a right angle to the H shaped piece, designed for holding a rest when it is desired to employ the face of the wheel 5 for grinding.

The upper extremity of the bracket 7 terminates in a bearing piece 18, wherein is secured a shaft 19, carrying a block 20. The inner edge of the bearing piece 18 is cut away or beveled for a portion of the circumference, as at 21, and a pin 22, fixed in the block 20, will strike against the stop 23 when the block 20 is turned upward, limiting the movement of the shaft 19 in the bearing 18 to a half revolution. Extending backward from the block 20, at an angle to the bearing 18, is a grooved rod, 24. Movable mounted on this rod is a block 25, said block being held against rotation by a pin 26, and secured in place by means of a thumb screw 27.

28 is a shaft movably mounted in a perforation in block 25, the inner extremity of said shaft having a concave cavity for the reception of the butt of a drill 29, and the outer end being provided with a circumferential groove 30 wherein fits a button 31 mounted

upon a screw 32 provided with a manipulating head 33. This screw 32 engages with a thread cut in a perforation in block 25, and is employed for delicately adjusting the drill for grinding.

The inner extremity of the block 20 is beveled, and provided with a fixed rest or tongue 34, adapted and arranged to enter the groove or twist in a drill of any size, the two edges of the groove being firmly seated upon the top and side of said tongue. Pivoted at 35 upon the block 20, is a movable finger 36, said finger also entering the groove or twist in the drill upon the opposite side from the fixed tongue, and striking both edges of the groove in such a manner as to firmly and securely hold it in the proper position. The finger 36 is provided with a thumb-piece 37 for operating the same, and is normally held in engagement with the drill by a spring 38.

With my improved drill holder and grinder any size of drill may be easily, quickly and accurately ground. The tail block 25 may be advanced or withdrawn from the chuck to suit the length of drill, and then the face of the drill accurately adjusted by means of the adjusting screw placed in said block. By raising the movable finger of the holder, the inner extremity of the drill will fall to place upon the tongue, always at the right angle, no matter what the fineness of the drill may be, and the movable finger will fall to place in the upper groove, when released, the point of the drill being thus firmly held and supported at four points. In grinding, the bracket is rocked backward, and the block 20 carrying all the supporting and holding parts of the drill is rocked in its support, giving the drill just the proper cutting face and bevel. After one side of the drill is ground, it is simply turned half a revolution, and the movement of the parts backward, and the rotation of the same is repeated. It will thus be seen that my device admirably answers the uses and purposes for which it is intended, as the proper cutting edge and bevel must always be given to the drill, and both sides must be precisely alike, insuring the proper cutting of the tool when put to use.

Having now fully described my invention, what I claim as new therein, and desire to secure by Letters Patent, is—

1. In a drill grinder of the character herein specified, a drill holder, consisting of a fixed tongue, the extremity whereof is adapted and arranged to enter the grooves diagonally in one side of the drill and support both edges

of said groove, in combination with a movable finger the extremity of which enters the opposite groove in the drill and bears upon both edges thereof, substantially as shown and described.

2. In a drill grinder, a movable bracket mounted upon the main frame, said bracket bearing a drill holder, movably mounted thereon, said holder having a fixed tongue, the extremity whereof is adapted to enter the groove in one side of the drill and a spring-actuated movable finger, arranged to enter the opposite groove in a drill, the whole combined and arranged substantially as shown and described.

3. The combination with the main frame, of a shaft whereon is mounted a bracket; a movable block mounted in said bracket and bearing a shaft extending at an angle to the grinding wheel mounted upon a shaft in the main frame; a fixed tongue and a movable finger secured to the movable block, and means for regulating the longitudinal movement of a drill when placed in position for grinding, substantially as shown and described.

4. In a device of the character herein specified, an H shaped piece, having bearings at top and bottom, the upper bearing being arranged for the spindle of a grinding wheel, and the lower to support a drill holding device, said H-shaped piece being adapted to be secured to a support, substantially as shown and described.

5. In a drill grinder of the character herein specified, the combination with the movable bracket, having an arm wherein is rotatably placed a shaft, of a block mounted upon said shaft and bearing a fixed tongue at its inner extremity, and a movable finger provided with a manipulating thumb-piece, said tongue and finger forming a drill holder, substantially as shown and described.

6. In a drill grinder of the character herein specified, a drill holder consisting of a fixed tongue the extremity whereof is adapted and arranged to enter the groove on one side of a drill, and support the same in a rigid position, and a spring-actuated movable finger, provided with a thumb-piece, said finger being arranged to enter the groove in the drill opposite to the fixed tongue, substantially as shown and described.

THOMAS HALL.

Witnesses:

A. M. PIERCE,  
ISABEL CHESTER.