

(19) World Intellectual Property Organization
International Bureau



(43) International Publication Date
9 August 2007 (09.08.2007)

PCT

(10) International Publication Number
WO 2007/089631 A2

- (51) International Patent Classification:
A61B 17/00 (2006.01)
- (21) International Application Number:
PCT/US2007/002250
- (22) International Filing Date: 26 January 2007 (26.01.2007)
- (25) Filing Language: English
- (26) Publication Language: English
- (30) Priority Data:
60/762,306 26 January 2006 (26.01.2006) US
- (71) Applicant (for all designated States except US): EAST CAROLINA UNIVERSITY [US/US]; 2200 Charles Boulevard, Greenville Centre, Room 2400, Greenville, NC 27858 (US).
- (72) Inventors; and
- (75) Inventors/Applicants (for US only): MALLETTE, Julius [US/US]; 517 Crestline Blvd., Greenville, North Carolina 27858 (US). BOSSICK, IV, John [US/US];

- 33 Alfred Court, Raleigh, North Carolina 27603 (US). RASSAU, Thomas J. [US/US]; 3702 Tucker Drive, Greenville, North Carolina 27858 (US).
- (74) Agent: MYERS BIGEL SIBLEY & SAJOVEC, P.A.; P.O. Box 37428, Raleigh, NC 27627 (US).
- (81) Designated States (unless otherwise indicated, for every kind of national protection available): AE, AG, AL, AM, AT, AU, AZ, BA, BB, BG, BR, BW, BY, BZ, CA, CH, CN, CO, CR, CU, CZ, DE, DK, DM, DZ, EC, EE, EG, ES, FI, GB, GD, GE, GH, GM, GT, HN, HR, HU, ID, IL, IN, IS, JP, KE, KG, KM, KN, KP, KR, KZ, LA, LC, LK, LR, LS, LT, LU, LV, LY, MA, MD, MG, MK, MN, MW, MX, MY, MZ, NA, NG, NI, NO, NZ, OM, PG, PH, PL, PT, RO, RS, RU, SC, SD, SE, SG, SK, SL, SM, SV, SY, TJ, TM, TN, TR, TT, TZ, UA, UG, US, UZ, VC, VN, ZA, ZM, ZW.
- (84) Designated States (unless otherwise indicated, for every kind of regional protection available): ARIPO (BW, GH, GM, KE, LS, MW, MZ, NA, SD, SL, SZ, TZ, UG, ZM, ZW), Eurasian (AM, AZ, BY, KG, KZ, MD, RU, TJ, TM), European (AT, BE, BG, CH, CY, CZ, DE, DK, EE, ES, FI, FR, GB, GR, HU, IE, IS, IT, LT, LU, LV, MC, NL, PL, PT,

[Continued on next page]

(54) Title: MEDICAL SCISSORS SUITABLE FOR C-SECTION SURGERIES AND RELATED METHODS

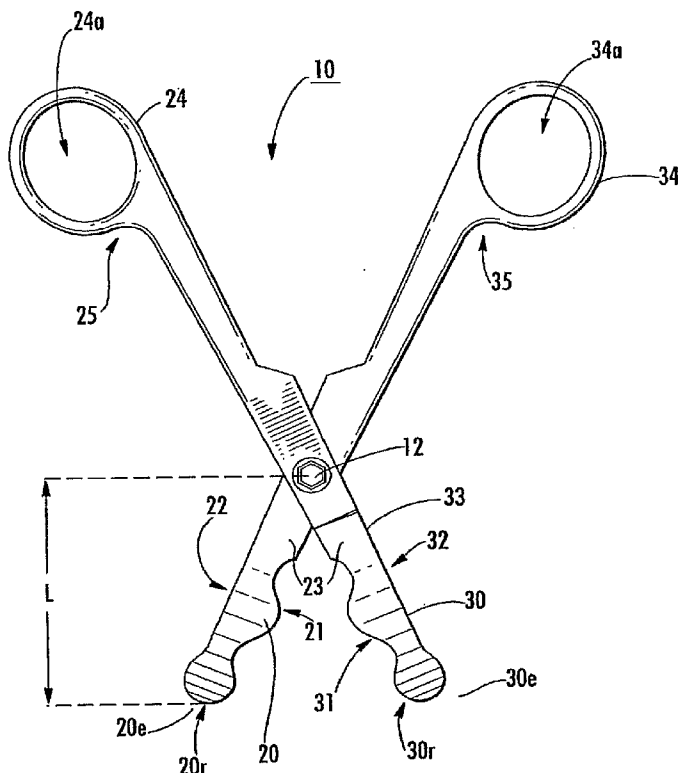

(57) Abstract: Surgical scissors include first and second elongate cooperating members that close to cut target tissue. Each of the first and second elongate members include a rounded forward edge portion and/or a curvilinear inner perimeter (the blade side of the elongate members).

WO 2007/089631 A2



RO, SE, SI, SK, TR), OAPI (BF, BJ, CF, CG, CI, CM, GA, GN, GQ, GW, ML, MR, NE, SN, TD, TG).

For two-letter codes and other abbreviations, refer to the "Guidance Notes on Codes and Abbreviations" appearing at the beginning of each regular issue of the PCT Gazette.

Published:

— *without international search report and to be republished upon receipt of that report*

Attorney Docket No. 5218-151WO

**MEDICAL SCISSORS SUITABLE FOR C-SECTION SURGERIES AND
RELATED METHODS**

5

RELATED APPLICATIONS

This application claims priority to U.S. Provisional Application Serial No. 60/762,306, filed January 26, 2006, the disclosure of which is hereby incorporated by reference in its entirety.

10

FIELD OF THE INVENTION

The invention relates to surgical tools that are particularly suitable for cesarean section ("C-section") procedures.

15

BACKGROUND OF THE INVENTION

Conventional gynecologic surgeries typically use sharp Sims scissors, which have upwardly curved blades, sharp forward edges and/or blunt tips.

SUMMARY OF EMBODIMENTS OF THE INVENTION

20

Embodiments of the invention provide for medical scissors having enhanced safety features.

25

Embodiments of the present invention are directed to surgical scissors that can inhibit fetal lacerations and inadvertent trans-sections of a uterine artery during cesarean section. Alternatively or additionally, the scissors may allow for clean incision edges facilitating closure of a uterine incision after delivery.

In some embodiments, surgical scissors include first and second elongate cooperating members that close to cut target tissue. Each of the first and second elongate members include a rounded forward edge portion.

30

The surgical scissors may optionally have cooperating laterally extending (typically rounded) projections and recesses configured to trap tissue. The recesses may have a tissue contacting surface configured with an anti-slip texture and/or coating.

The scissors may be particularly useful for a cesarean-section surgery. The scissors may also be useful for other medical situations, such as EMT applications.

Other embodiments are directed to surgical scissors that include first and second elongate cooperating members that close to cut target tissue. Each of the first and second elongate members include at least one cooperating laterally outwardly extending tissue stabilizing projection on a respective inner perimeter surface thereof.

5 In operation, the projections travel closer together to trap tissue and inhibit slippage.

Some embodiments are directed toward methods of facilitating a cesarean section. The methods include: (a) trapping tissue between first and second laterally extending stabilizing projections disposed across from each other on elongate members of surgical scissors to inhibit slipping; and (b) cutting tissue with the
10 elongate members of the surgical scissors while the tissue is trapped.

The methods may optionally include making a complete uterine incision using the scissors without manual pressure to extend the incision thereby providing clean incision edges whereby closure of the uterine after surgery is facilitated, wherein the scissors have rounded tips that are sized and configured sufficiently large to keep a
15 sharp portion of a blade of the scissors away from a uterine artery while making the uterine incision.

Further features, advantages and details of the present invention will be appreciated by those of ordinary skill in the art from a reading of the figures and the detailed description of the embodiments that follow, such description being merely
20 illustrative of the present invention.

BRIEF DESCRIPTION OF THE DRAWINGS

Figure 1 is a top view of exemplary surgical scissors according to embodiments of the present invention.

25 **Figure 2** is an enlarged side perspective view of surgical scissors similar to that shown in **Figure 1** according to embodiments of the present invention.

Figure 3 is an enlarged opposing side perspective view of the scissors shown in **Figure 2**.

Figure 4 is a greatly enlarged top perspective view of the scissors shown in
30 **Figure 2**.

Figure 5 is a side perspective view of another embodiment of scissors according to embodiments of the present invention.

Figure 6A is a bottom view of one elongate member of medical scissors and **Figure 6B** is a bottom view of the other elongate member of the scissors according to embodiments of the present invention.

Figure 6C is an enlarged view of the lower portion of the member shown in **Figure 6A** according to embodiments of the present invention.

Figure 7 is a schematic illustration of surgical scissors in a protective sterile package according to embodiments of the present invention.

Figures 8A-8C are partial top views of different exemplary tip configurations for surgical scissors according to embodiments of the present invention.

Figure 9A is an exploded top perspective view of an elongate member for surgical scissors having weights enclosed therein according to embodiments of the present invention.

Figure 9B is a cross sectional view along the lines **B-B** of **Figure 9A**.

Figure 10A is an exploded top perspective view of an elongate member for surgical scissors having weights enclosed therein according to embodiments of the present invention.

Figure 10B is a cross sectional view along the lines **B-B** of **Figure 10A**.

Figure 11A is a top view of exemplary surgical scissors with a releasably attached handle and/or blade set according to embodiments of the present invention.

Figure 11B is a top view of another exemplary surgical scissors with a releasably attached handle and/or blade set according to embodiments of the present invention.

Figure 12 is a perspective view of the handle portion of the surgical scissors of **Figure 11B**.

Figure 13 is a partial cross sectional view of a portion of the blade and the handle portion of the surgical scissors of **Figure 11B**.

Figure 14 is a side perspective view of the blade set of the surgical scissors of **Figure 11B**.

30 DETAILED DESCRIPTION

The present invention now is described more fully hereinafter with reference to the accompanying drawings, in which embodiments of the invention are shown. This invention may, however, be embodied in many different forms and should not be construed as limited to the embodiments set forth herein; rather, these embodiments

are provided so that this disclosure will be thorough and complete, and will fully convey the scope of the invention to those skilled in the art.

Like numbers refer to like elements throughout. In the figures, the thickness of certain lines, layers, components, elements or features may be exaggerated for clarity. Broken lines illustrate optional features or operations unless specified otherwise.

The terminology used herein is for the purpose of describing particular embodiments only and is not intended to be limiting of the invention. As used herein, the singular forms "a", "an" and "the" are intended to include the plural forms as well, unless the context clearly indicates otherwise. It will be further understood that the terms "comprises" and/or "comprising," when used in this specification, specify the presence of stated features, integers, steps, operations, elements, and/or components, but do not preclude the presence or addition of one or more other features, integers, steps, operations, elements, components, and/or groups thereof. As used herein, the term "and/or" includes any and all combinations of one or more of the associated listed items. As used herein, phrases such as "between X and Y" and "between about X and Y" should be interpreted to include X and Y. As used herein, phrases such as "between about X and Y" mean "between about X and about Y." As used herein, phrases such as "from about X to Y" mean "from about X to about Y."

Unless otherwise defined, all terms (including technical and scientific terms) used herein have the same meaning as commonly understood by one of ordinary skill in the art to which this invention belongs. It will be further understood that terms, such as those defined in commonly used dictionaries, should be interpreted as having a meaning that is consistent with their meaning in the context of the specification and relevant art and should not be interpreted in an idealized or overly formal sense unless expressly so defined herein. Well-known functions or constructions may not be described in detail for brevity and/or clarity.

It will be understood that when an element is referred to as being "on", "attached" to, "connected" to, "coupled" with, "contacting", etc., another element, it can be directly on, attached to, connected to, coupled with or contacting the other element or intervening elements may also be present. In contrast, when an element is referred to as being, for example, "directly on", "directly attached" to, "directly connected" to, "directly coupled" with or "directly contacting" another element, there are no intervening elements present. It will also be appreciated by those of skill in

the art that references to a structure or feature that is disposed "adjacent" another feature may have portions that overlap or underlie the adjacent feature.

It will be understood that, although the terms first, second, etc. may be used herein to describe various elements, components, regions, layers and/or sections, 5 these elements, components, regions, layers and/or sections should not be limited by these terms. These terms are only used to distinguish one element, component, region, layer or section from another region, layer or section. Thus, a first element, component, region, layer or section discussed below could be termed a second 10 element, component, region, layer or section without departing from the teachings of the present invention. The sequence of operations (or steps) is not limited to the order presented in the claims or figures unless specifically indicated otherwise.

Figure 1 illustrates one embodiment of medical (surgical) scissors **10**. As shown, the scissors **10** include a cooperating pair of elongate members **20**, **30**, 15 respectively. The tip or forward edge portion **20e**, **30e** of each member **20**, **30**, respectively, can have a lobe that has a rounded shape **20r**, **30r**. The terms "lobe" means a rounded projecting part. The terms "rounded" and "rounded shape" means that there are no sharp points. As also shown in **Figure 1**, in some embodiments, the inner perimeter (blade side) of each member **21**, **31**, can have a curvilinear shape and the outer perimeter **22**, **32** may have a generally straight edge. In other 20 embodiments, the outer perimeter **22**, **33** may have alternative shapes, such as substantially the same curvilinear shape as the inner perimeter **21**, **31**.

The scissors **10** can have a relatively short length to allow for better surgeon "feel" as well as an increased control of a cut of target tissue during a surgical 25 procedure. In some embodiments, the scissors **10** can have a length of between about 13 cm to about 20 cm, and more typically is between about 14-15 cm. As shown in **Figure 1**, the scissors **10** include a pivot joint **12**. The elongate members **20**, **30** can have a length **L** that extends from a medial portion of the pivot joint **12** to the forwardmost end of the rounded tips **20r**, **30r** of between about 3 cm to about 6 cm, and is typically between about 4.5 cm to about 5.5 cm. The pivot joint **12** can be 30 disposed closer to the rounded tips **20r**, **30r** than the opposing handle end **24**, **34** of the scissors **10**. The pivot joint **12** can be configured to provide increased cutting force without requiring that excess pressure be applied to the handles **24**, **34**.

At least a subportion of the length of the inner perimeter **21**, **31** defines the cutting blade portion of the scissors **10**. That is, the cutting edge **23**, **33** may reside

closer to the pivot joint **12** spaced apart from the rounded forward edge **20r**, **30r** and is typically spaced back from a forwardmost edge of the elongate members **20**, **30** forming the scissors body. In other embodiments, the blade **23**, **33** can extend substantially the entire length of the inner perimeter of the elongate members **20**, **30** below the pivot **12** and typically rearward of the forwardmost edge a suitable distance.

During a C-section and other surgeries, a blood field of view with limited visualization can exist, such as, for example, upon surgical entry into the uterine cavity to deliver a newborn baby. The rounded edges **20r**, **30r** can be substantially bulbous and configured to allow closure of the scissors **10** without the risk of a sharp edge of the blade contacting the uterine artery or the baby during incision with the scissors **10**.

As shown in **Figure 6C**, the radius of the tip **20r** (shown as member **20** but can apply to member **30** as well) can be such that it defines a perimeter (outermost or forwardmost) portion **20p** which is blunt or dull. The sharp edge **20s** is rearward a distance **Ls**. The distance **Ls** is sufficient to place the point of contact with the sharp edge at least about 0.5 cm from the forwardmost edge, and typically at least about 0.8 cm. In the latter, this dimension will place the point of contact at least about 0.8 cm from a baby's face and also at least about 0.8 cm from the uterine wall edge. This distance **Ls** can allow for tissue compression without contact to sensitive regions thereby preventing the sharp edge from touching the baby's face or uterine artery inadvertently.

The scissors **10** has a handle end **24**, **34** with respective finger holes or apertures **20a**. The inner perimeter of the handle defining the apertures **24a**, **34a** can be radiused for comfort. In addition, the outer perimeter of the neck portion **25**, **35** of the elongate members **20**, **30** may also be radiused to cradle a surgeon's index finger for increased control and feel. Still further, a finger resting projection **38** may be formed on the neck portion of one or more of the members (see, e.g., **Figure 6B**) to define a finger rest recess **39** between the radiused neck **35** and the projection **38**.

Figure 2 illustrates that the elongate members **20**, **30** may have a curvature **25**, **35** so that at least a lower portion of each of the first and second elongate members **20**, **30** curve upwardly relative to the direction of the scissors' stroke. The radius of curvature "**r₁**" can be between about 19.3 cm to about 19.5 cm.

The enlarged views of the scissors **10** shown in **Figures 3** and **4** illustrate the rounded edge portions **20r**, **30r** and the curvilinear shape of the inner perimeters **21**,

31. In some embodiments, the rounded edge portion **20r**, **30r** can be configured to inhibit (typically prevent) inadvertent tissue damage and/or damage to a baby's skull during incision in a C-section procedure. The scissors **10** can be configured to allow a complete uterine incision using the scissors **10** without manual pressure to extend the
5 incision, thereby providing clean incision edges to facilitate closure of the uterine after surgery. This can require less upper body strength than conventional procedures. The scissors **10** have rounded edges **20r**, **30r** that can be sized and configured sufficiently large to keep a sharp portion of a blade of the scissors away from a uterine artery while making the uterine incision.

10 As shown in **Figures 3, 5** and **8A-8C**, the rounded forward edge portion **20r**, **30r** of each of the first and second members can have various rounded shapes, each having at least a portion with an arcuate shape. In some embodiments, the radius of the arcuate segment or shape " r_2 " can be between about 3 mm to about 10 mm, and is typically between about 8 mm to about 10 mm. **Figure 8C** also illustrates that the
15 outermost edge of the rounded shape **20r**, **30r** may be scalloped or may otherwise vary in radius of curvature. In some embodiments, as shown in **Figure 3**, the rounded forward edge portions **20r**, **30r** are substantially circular and configured so that the substantially circular (*i.e.*, substantially completely rounded) forward edges merge into a narrower adjacent neck portion **20n**, **30n**, respectively, then flare transversely
20 outward to define a projection **29**, **39**, respectively, along the inner perimeter surface **21**, **31**. The term "substantially circular" refers to a substantially circular circumferential perimeter shape that extends for at least about 270 degrees.

Figure 5 illustrates that the forward edge **20r'**, **30r'** can be semi-circular, with at least a forward and outer portion of the tip comprising a semi-circular perimeter
25 shape. In some embodiments, the semi-circular shape has a radius of between about 3 mm to about 10mm, and typically between about 4 mm to about 8 mm. The semi-circular shape can be at least a half-circle (typically at least three-fourths of a circle).

As shown, for example, in **Figure 6**, the projections **29**, **39** can be intermediate two recesses **129₁**, **129₂** and **139₁**, **139₂**, respectively. **Figure 8C**
30 illustrates that at least one of the recesses **129₁**, **139₁** can include an anti-slip surface **200** formed of an embossed, notched, or textured surface and/or a coating or anti-slip material.

As shown in **Figure 1**, the curvilinear inner perimeter **21**, **31** of the first and second members **20**, **30**, respectively can have substantially the same perimeter shape.

However, each may have a different shape as well (not shown). As shown, for example in **Figure 4**, the projections **29, 39** are a substantially arcuate laterally extending projection. The respective projections **29, 30** are typically substantially axially aligned to face each other such that in a closed configuration the projection **39** of one member **30** resides above the projection **29** of the other member **20**. The curvilinear perimeter **21, 31** includes at least one substantially arcuate recess disposed closer to the handle than the at least one projection. The dimensions of the lobes (projections) **29, 39** and recesses **129₁, 129₂** and **139₁, 139₂** can vary. It is contemplated that a recess radius of between about 0.5 cm to about 10 cm may be suitable, with a typically recess radius of about 0.8 cm, so as to be sufficiently deep to hold the target tissue in place. Similarly, a lobe projection radius of between about 0.5 cm to about 1.0 cm, typically between about 0.8 cm to about 1.0 cm, can allow the lobes **29, 39** to project sufficiently without extending too far over the edge of the opposing blade when the scissors are closed, which may be desirable in some embodiments. Thus, in some embodiments, when closed the scissors **10** are configured so that projections **29, 39** of each respective blade **20, 30** do not extend beyond the bounds of the other, *i.e.*, the lobe projection **29** of the blade **20** lies does not overhang and/or transversely extend beyond the bounds of the other blade **30**.

Figure 7 illustrates the scissors **10** in a sterile package **250**. That is, the scissors **10** can be sterilized and placed in a sterile sealant ready for use during a medical procedure. The scissors **10** can be configured to be re-sterilized and re-used or may be single-use disposable. The scissors **10** and/or elongate members **20, 30** can be metallic. In other embodiments, scissors **10** (at least the elongate members **20, 30** thereof) are substantially rigid and non-metallic. For example, the scissors **10** and/or elongate members **20, 30** can comprise a rigid polymer, ceramic or composite.

In particular embodiments, the scissors **10** comprise an elastomeric material, for example, a polymer, copolymer or derivatives thereof. In other embodiments, the scissors and/or the elongate members comprise a composite (resin reinforced fiber) material. In yet other embodiments, the scissors comprise a ceramic material.

The elongate members forming the scissors can be a unitary member molded or otherwise formed or may include different components of different or the same materials attached together.

In some particular embodiments, at least a portion of the forward edge **20r**, **30r** may be flexible or resiliently configured with, for example, a compressible forward edge coating, cap or other configuration to inhibit tissue damage.

In some embodiments, the scissors **10** can be formed of at least two materials.

5 In particular embodiments, at least one portion of the scissors **10** is single-use disposable. Accordingly, portions of the scissors **10** likely to come in contact with tissue or bodily fluids can be formed a single-use disposable material, and a reusable portion of the scissors **10** can be used to provide additional weight, for example, to accommodate surgeons who may desire surgical instruments that are heavier than
10 typical disposable materials. In some embodiments, the scissors **10** can include a single-use disposable portion with high density inserts.

For example, the scissors **10** can include a disposable outer housing or casing and may be matable and be formed as portions which may be formed of different materials and/or different weights. The disposable outer casing can be configured to
15 enclose one or more weighted elements that are formed of the material that is heavier than the outer housing or casing. The weighted elements may be reusable, sterilizable and/or provide additional weight to the disposable outer casing so that the total weight of the scissors is approximately of a standard stainless steel surgical instrument. For example, the weight of the scissors can be between 75 to 100 grams. For example,
20 the weighted elements may be formed of metal, such as stainless steel, and the disposable outer casing can be formed of an elastomeric material, such as polymer, copolymer or derivatives thereof or of a composite (resin reinforced fiber)

In other particular embodiments, the blade or elongate members can be formed of a single-use disposable material (*e.g.*, elastomeric or composite materials), and can
25 be releasably attached to reusable handles. The handles can be formed of metal, such as stainless steel, and may be sterilizable.

For example, as shown in **Figures 9A-9B**, an elongate member **300** includes a body **310** with a base **310a** and a cover **310b**. The base **310a** includes recesses **315** that are configured to receive weights **316** therein. The cover **310b** is secured to the
30 base **310a**, and can seal the weights **316** in the body **310** to reduce (and typically prevent) contact between the weights **316** and bodily fluids and/or tissue during use. The cover **310b** can be secured to the base **310a** by a mechanical seal (such as a snap fit or tongue and groove seal) and/or an adhesive may be used.

The recesses **315** can be sized and configured so that the corresponding weights **316** create an appropriate weight distribution for ease of use, and in some instances, to mimic conventional stainless steel surgical instruments. Alternative embodiments with different weight distributions are shown in **Figures 10A-10B**. The elongate member **400** includes a body **410** with a base **410a** and a cover **410b**. The base **410a** includes recesses **415** that are configured to receive the weights **416** therein. As described with respect to **Figures 9A-9B**, the cover **410b** is secured to the base **410a**, and can seal the weights **416** in the body **410**.

It should be understood that the elongate members **300, 400** may be combined with a corresponding elongate member (not shown) to form a scissors, such as with the two elongate members **20, 30** shown, for example, in **Figure 1**.

Figure 11A illustrates scissors **500**, which includes a blade set **504** having to cooperating elongate members **504A, 504B** and releasably attachable handle members **502**. As illustrated in **Figure 11A**, the elongate members **504A, 504B** extend to the finger openings on the handle members **502**. The elongate members **504A, 504B** can be disposable and formed of a polymeric and/or composite material, and the handle members **502** can be reusable and/or sterilizable. However, it should be understood that the elongate members **504A, 504B** can extend any suitable distance along the length of the handle members **502**. In some embodiments, the elongate members **504A, 504B** generally prevent or inhibit contact between the handle members **502** and bodily fluids and/or tissue.

For example, **Figures 11B-14** illustrate a scissors **500₁** that includes releasably attachable handle members **502** and a blade set **504₁**. The blade set **504₁** includes two cooperating elongate members **504A₁, 504B₁**. The handle members **502** can be formed of a re-usable material, such as metal (*e.g.*, stainless steel) and the blade set **504₁** can be single-use disposable, for example, formed of an elastomeric material. The handle members **502** may be formed of a material that is heavier than the blade set **504₁**.

The handle members **502** can be releasably attached to the blade set elongate members **504A₁, 504B₁**. For example, as shown in **Figure 14** the elongate members **504A₁, 504B₁** include apertures **506** for receiving a portion of the handle members **502**. As shown in **Figure 12**, the handle members **502** can include a notch **506**, and, as is shown in **Figure 13**, the elongate members **504A₁, 504B₁** can include a corresponding aperture **510** for receiving the notch **506** therein. In some

embodiments, a sealing member (not shown) can be used to seal the blade set **504₁** and the handle members **502** so as to inhibit or prevent blood or other bodily fluids or tissue from contacting the handle members **502** via the apertures **506** during use.

It should be understood that the elongate members **300, 400** and the scissors
5 **500, 500₁** may incorporate the features of the scissors **10** of **Figures 1-5, 6A-6C, 7**
and **8A-8C**.

The foregoing is illustrative of the present invention and is not to be construed
as limiting thereof. Although a few exemplary embodiments of this invention have
been described, those skilled in the art will readily appreciate that many modifications
10 are possible in the exemplary embodiments without materially departing from the
novel teachings and advantages of this invention. Accordingly, all such modifications
are intended to be included within the scope of this invention as defined in the claims.
The invention is defined by the following claims, with equivalents of the claims to be
included therein.

THAT WHICH IS CLAIMED:

1. Surgical scissors, comprising:
a first elongate member; and
5 a second elongate member pivotably attached to the first elongate member,
each having cutting edges that meet in a closed position, and wherein each of the
elongate members have a lobe end portion.
2. Surgical scissors according to Claim 1, wherein the lobe end portion defines
10 a rounded forward edge portion of each of the first and second members such that the
lobe end portion has a blunt substantially arcuate shape, and wherein at least a lower
portion of each of the first and second elongate members curves upwardly when
viewed from the side.
- 15 3. Surgical scissors according to Claim 1, wherein the lobe end portions are
substantially circular.
4. Surgical scissors according to Claim 3, wherein the elongate members are
configured so that the substantially circular end portions merge into a narrower neck
20 portion, then flare transversely outward along an inner surface.
5. Surgical scissors according to Claim 1, wherein the scissors are sterilized.
6. Surgical scissors according to Claim 5, wherein the scissors are packaged in
25 a sterile sealant.
7. Surgical scissors according to Claim 2, wherein each of the first and second
elongate members comprise a curvilinear inner edge, wherein a sharp cutting edge
portion of the inner edges of the elongate members resides a distance of at least about
30 8 mm rearward of a tip of the scissors.
8. Surgical scissors according to Claim 7, wherein the curvilinear inner edge
of the first and second members have substantially the same perimeter shape.

9. Surgical scissors according to Claim 8, wherein the curvilinear perimeter shape of each of the first and second members comprise a first substantially arcuate laterally extending projection, with the respective first projections being substantially axially aligned to face each other such that in a closed configuration the first
5 projection of the first member resides above the first projection of the second member.

10. Surgical scissors according to Claim 9, wherein the first and second elongate members include handles with finger apertures on an end opposing the lobe end portion, and wherein the curvilinear perimeter comprises at least one substantially
10 arcuate recess disposed closer to the handle than the at least one projection.

11. Surgical scissors according to Claim 2, wherein the arcuate shape is a semi-circular shape with a radius of between about 3 mm to about 10mm.
15

12. Surgical scissors according to Claim 11, wherein the semi-circular shape is at least a half-circle, and wherein the radius of the semi-circular shape is between about 4 mm to about 6 mm.

20 13. Surgical scissors according to Claim 1, wherein the elongate members have a length of between about 13 cm to about 20 cm.

14. Surgical scissors according to Claim 13, wherein the scissors are pivotably attached at a pivot joint, and wherein the elongate members have a length that extends
25 from a medial portion of the pivot joint to the forwardmost end of the lobe end portions that is between about 4.5 cm to about 5.5 cm.

15. Surgical scissors according to Claim 14, wherein the pivot joint is disposed closer to the lobe end portions than an opposing handle end of the scissors.
30

16. Surgical scissors according to Claim 1, wherein the elongate members are metallic.

17. Surgical scissors according to Claim 1, wherein the elongate members are

substantially rigid and non-metallic.

18. Surgical scissors according to Claim 17, wherein the elongate members are elastomeric.

5

19. Surgical scissors according to Claim 17, wherein the elongate members are composite.

20. Surgical scissors according to Claim 19, wherein the elongate members are ceramic.

10

21. Surgical scissors according to Claim 17, wherein the scissors are single-use disposable.

22. Surgical scissors according to Claim 10, wherein the recess has a tissue-contacting surface configured with an anti-slip texture and/or coating.

15

23. Use of the scissors of Claim 1 during a cesarean-section surgery.

24. Use of the scissors of Claim 1 for Emergency Medical Technician (EMT) applications.

20

25. Surgical scissors according to Claim 1, further comprising at least one weighted element enclosed in a portion of the elongate members.

25

26. Surgical scissors according to Claim 25, wherein at least the portion of the elongate members comprise an outer housing configured to enclose the at least one weighted element therein.

27. Surgical scissors according to Claim 26, wherein the outer housing is single-use disposable.

30

28. Surgical scissors according to Claim 26, wherein the outer housing is formed of a polymeric material.

29. Surgical scissors according to Claim 26, wherein the at least one weighted element is metallic.

5 30. Surgical scissors according to Claim 1, wherein the elongate members define a blade set with openings configured to receive a handle portion therein.

 31. Surgical scissors according to Claim 30, further comprising a handle portion releasably received in the elongate member apertures, the handle portion
10 having finger apertures on an end portion extending opposite the elongate members.

 32. Surgical scissors according to Claim 31, wherein the elongate members are single-use disposable.

15 33. Surgical scissors according to Claim 31, wherein the elongate members are polymeric and the handle portion is metallic.

 34. Surgical scissors, comprising:

 first and second elongate pivotably attached members that close to cut target
20 tissue, wherein each of the first and second elongate members comprise at least one cooperating laterally outwardly extending tissue stabilizing projection on a respective inner perimeter surface thereof, whereby, in operation, the projections travel closer together to trap tissue and inhibit slippage.

25 35. Surgical scissors according to Claim 34, wherein the first and second elongate members have bulbous end portions and a curvilinear inner edge, and wherein a respective sharp cutting edge of the elongate members is disposed a distance of at least about 0.5 cm from a forwardmost edge of the bulbous end portions.

30

 36. A method of facilitating a cesarean section surgery, comprising:
 trapping tissue between first and second laterally extending stabilizing projections disposed across from each other on elongate members of surgical scissors to inhibit slipping; and

cutting tissue with the elongate members of the surgical scissors while the tissue is trapped.

5 37. A method according to Claim 36, further comprising making a complete uterine incision using the scissors without manual pressure to extend the incision thereby providing clean incision edges whereby closure of the uterine after surgery is facilitated, wherein the scissors have rounded tips that are sized and configured sufficiently large to keep a sharp portion of a blade of the scissors away from a uterine artery while making the uterine incision.

10

38. Surgical scissors, comprising:

a first elongate member; and

a second elongate member pivotably attached to the first elongate member, each having cutting edges that meet in a closed position, and wherein each of the
15 elongate members have a lobe end portion., and wherein at least a portion of the elongate members are single-use disposable and the scissors has a weight between about 75 and 100 grams.

20 39. Surgical scissors according to Claim 38, further comprising at least one weighted element enclosed in the single-use disposable portion of the elongate members.

25 40. Surgical scissors according to Claim 39, wherein the single-use disposable portion of the elongate members comprises an outer housing.

41. Surgical scissors according to Claim 40, wherein the outer housing is formed of a polymeric material.

30 42. Surgical scissors according to Claim 40, wherein the at least one weighted element is metallic.

43. Surgical scissors according to Claim 38, wherein the elongate members define a blade set with openings configured to receive a handle portion therein.

44. Surgical scissors according to Claim 43, further comprising a handle portion releasably received in the elongate member apertures, the handle portion having finger apertures on an end portion extending opposite the elongate members.

- 5 45. Surgical scissors according to Claim 44, wherein the elongate members are polymeric and the handle portion is metallic.

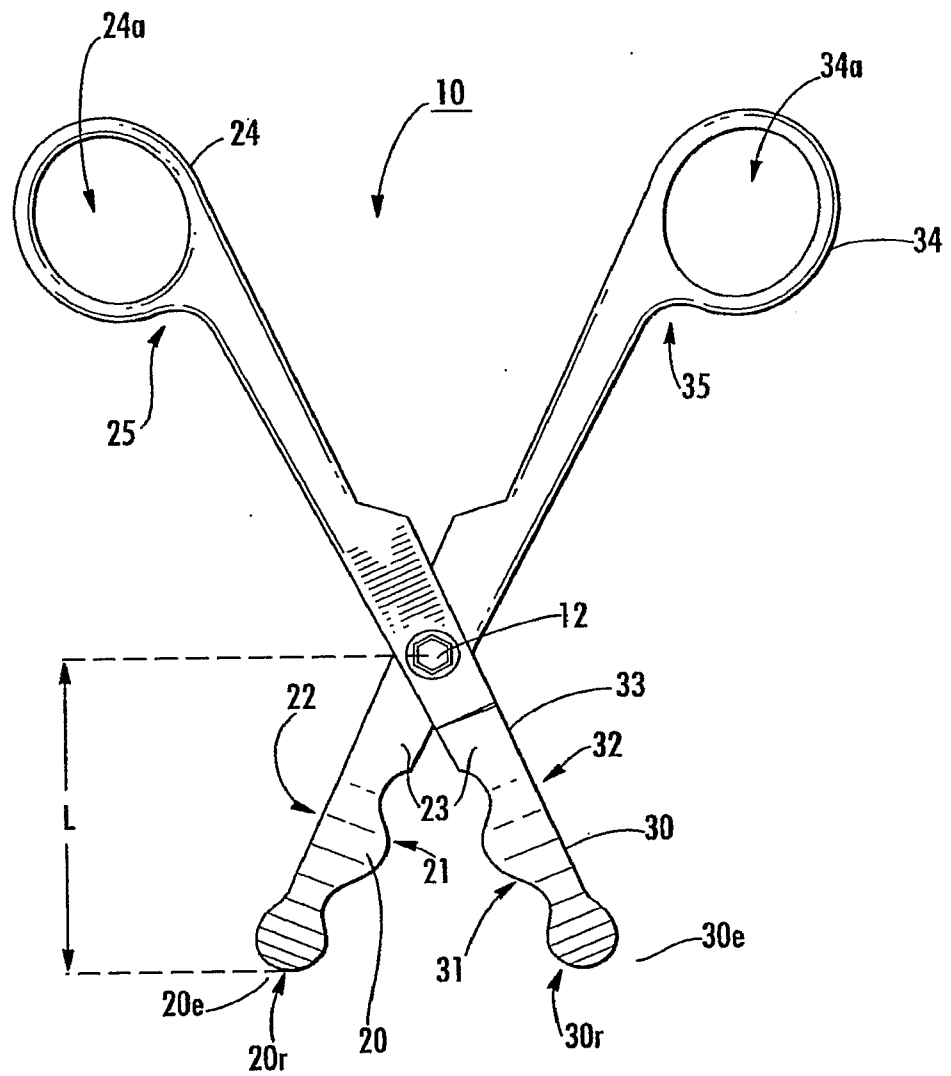

FIG. 1

2/13

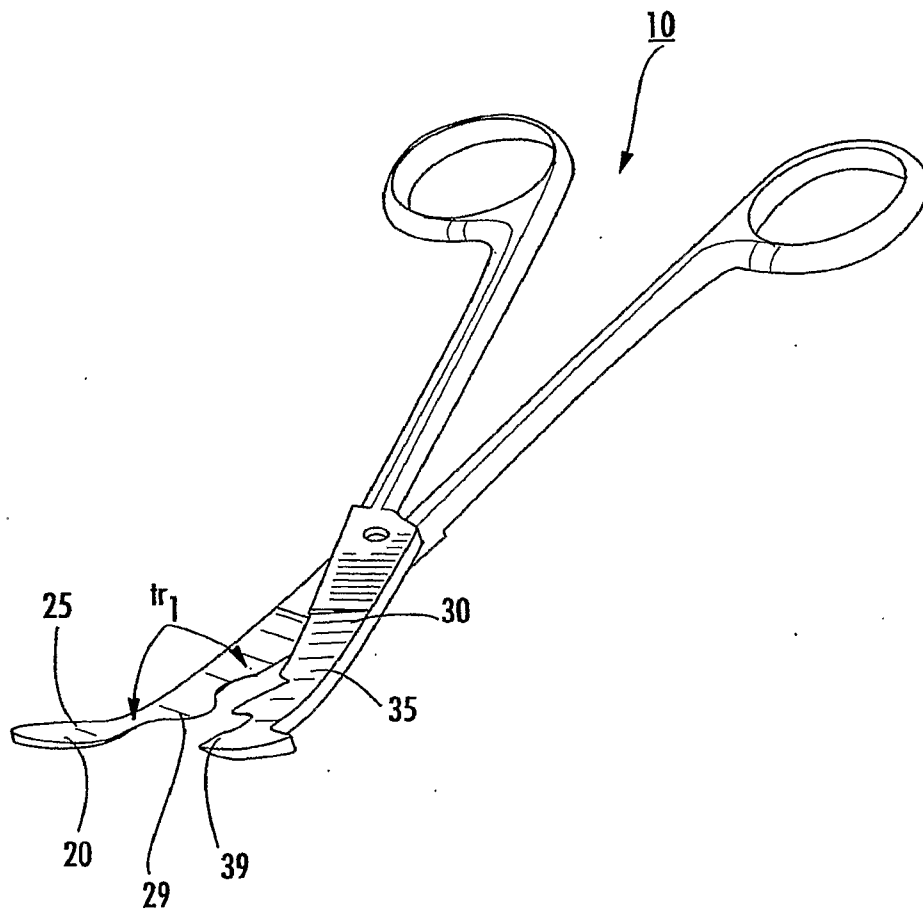

FIG. 2

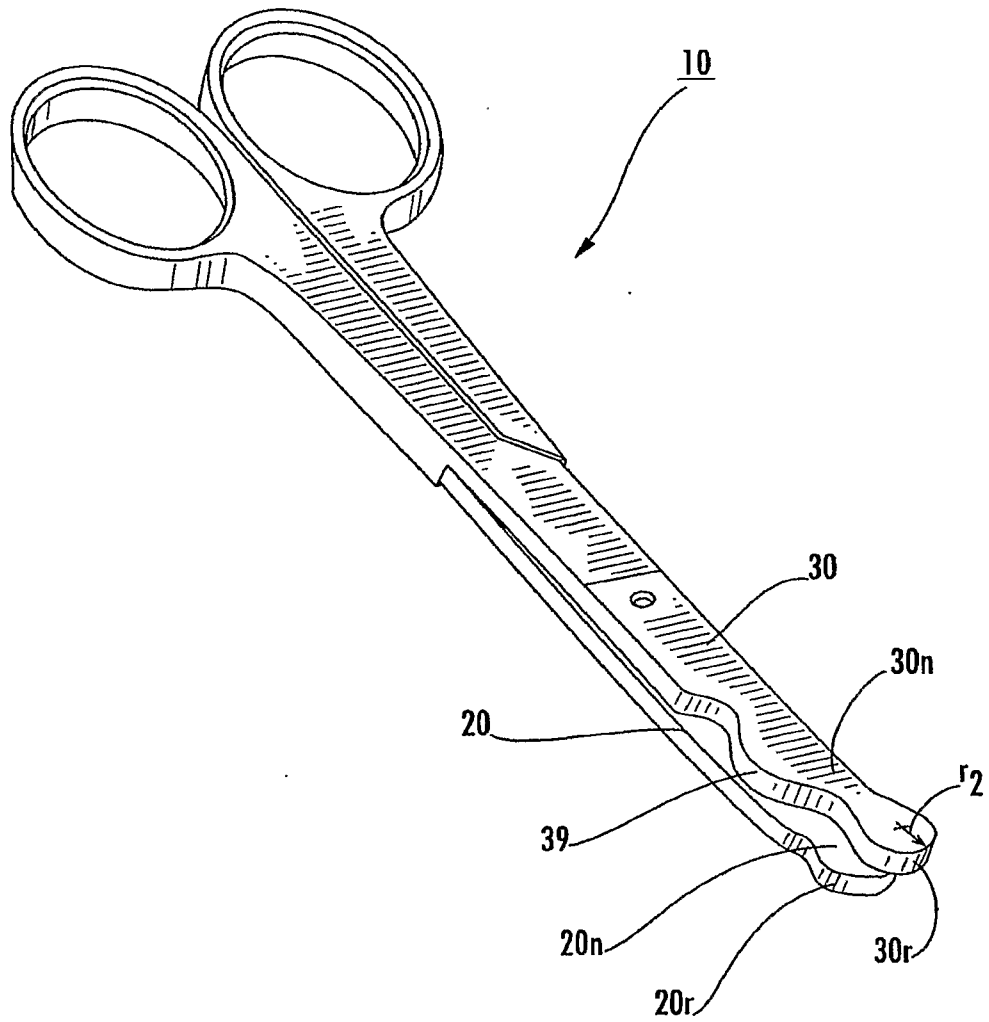

FIG.3

4/13

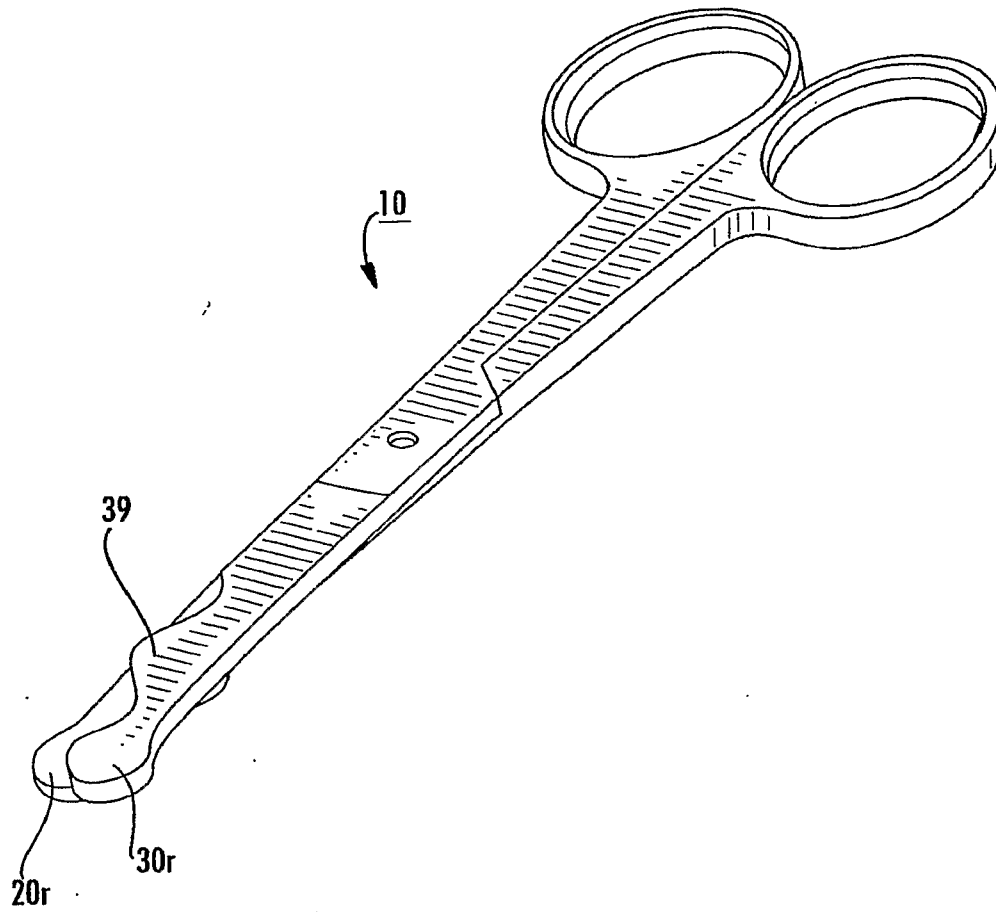

FIG.4

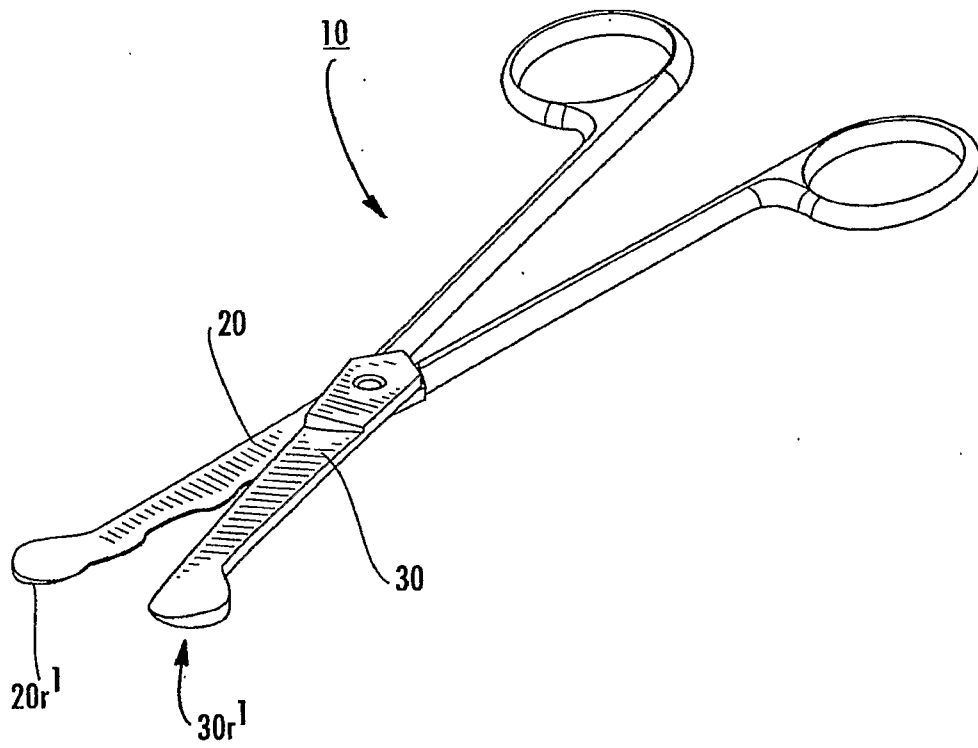
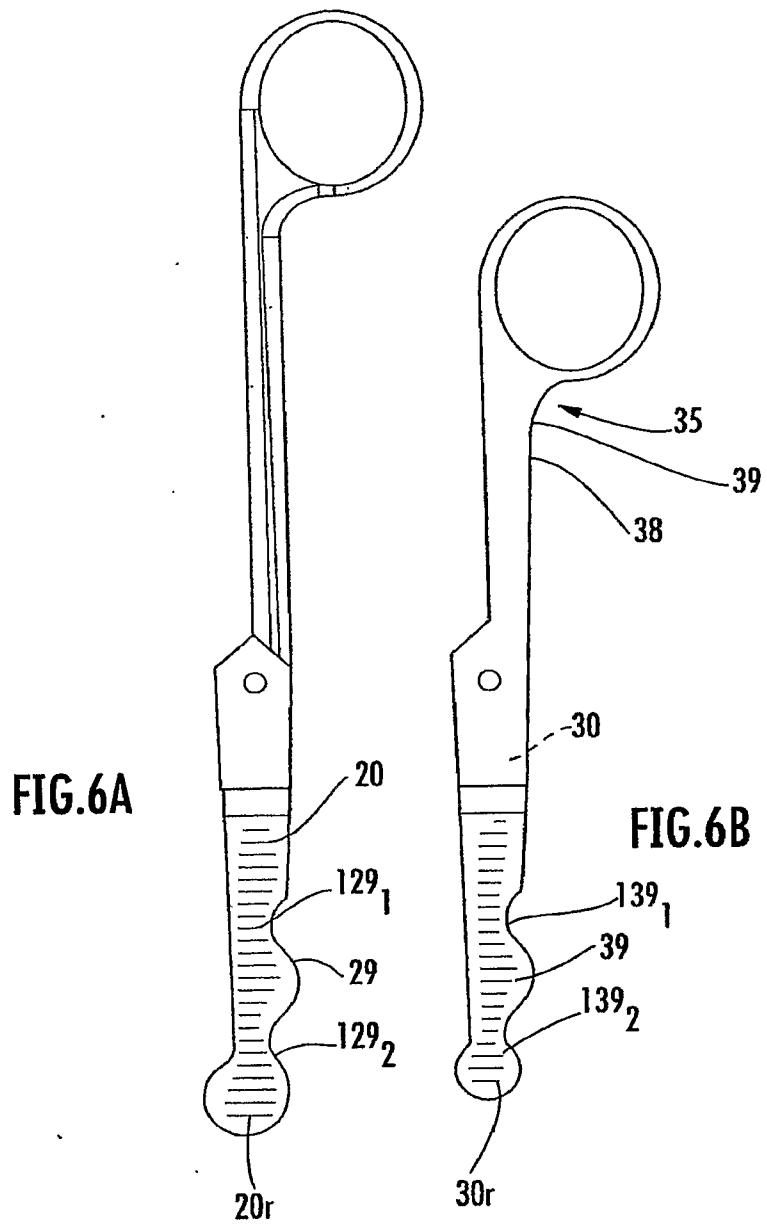

FIG.5



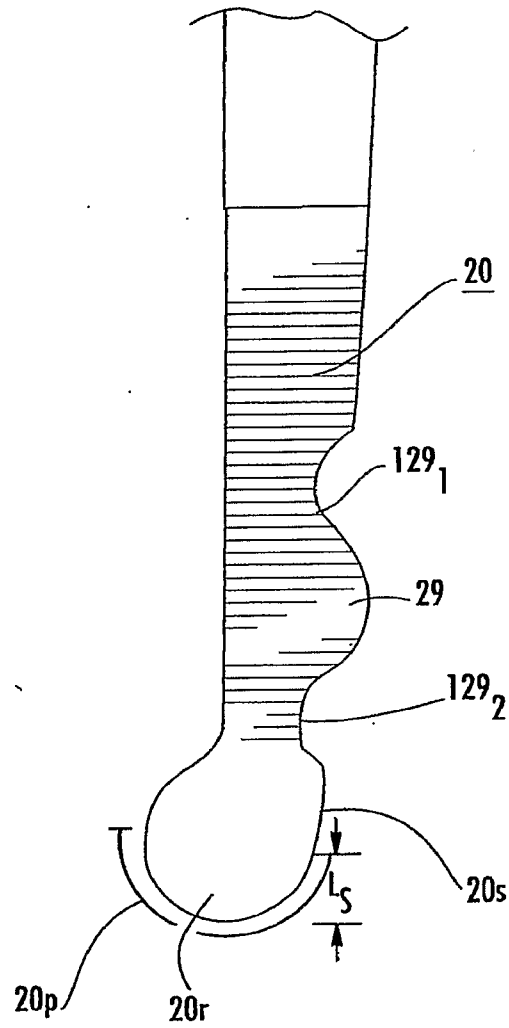

FIG.6C

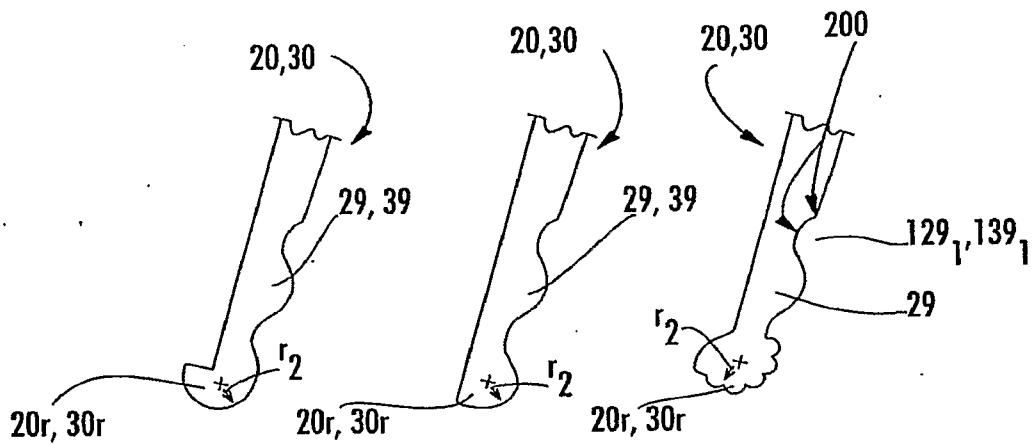

FIG.8A

FIG.8B

FIG.8C

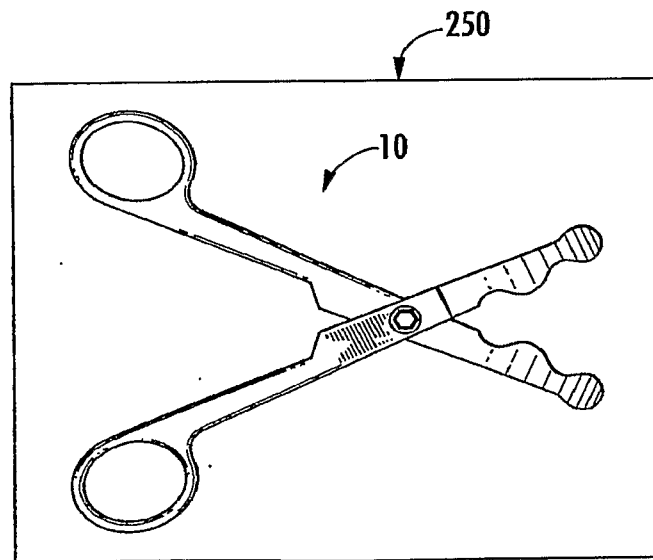

FIG.7

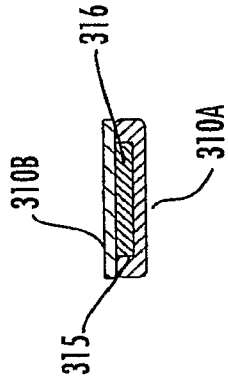

FIG. 9B

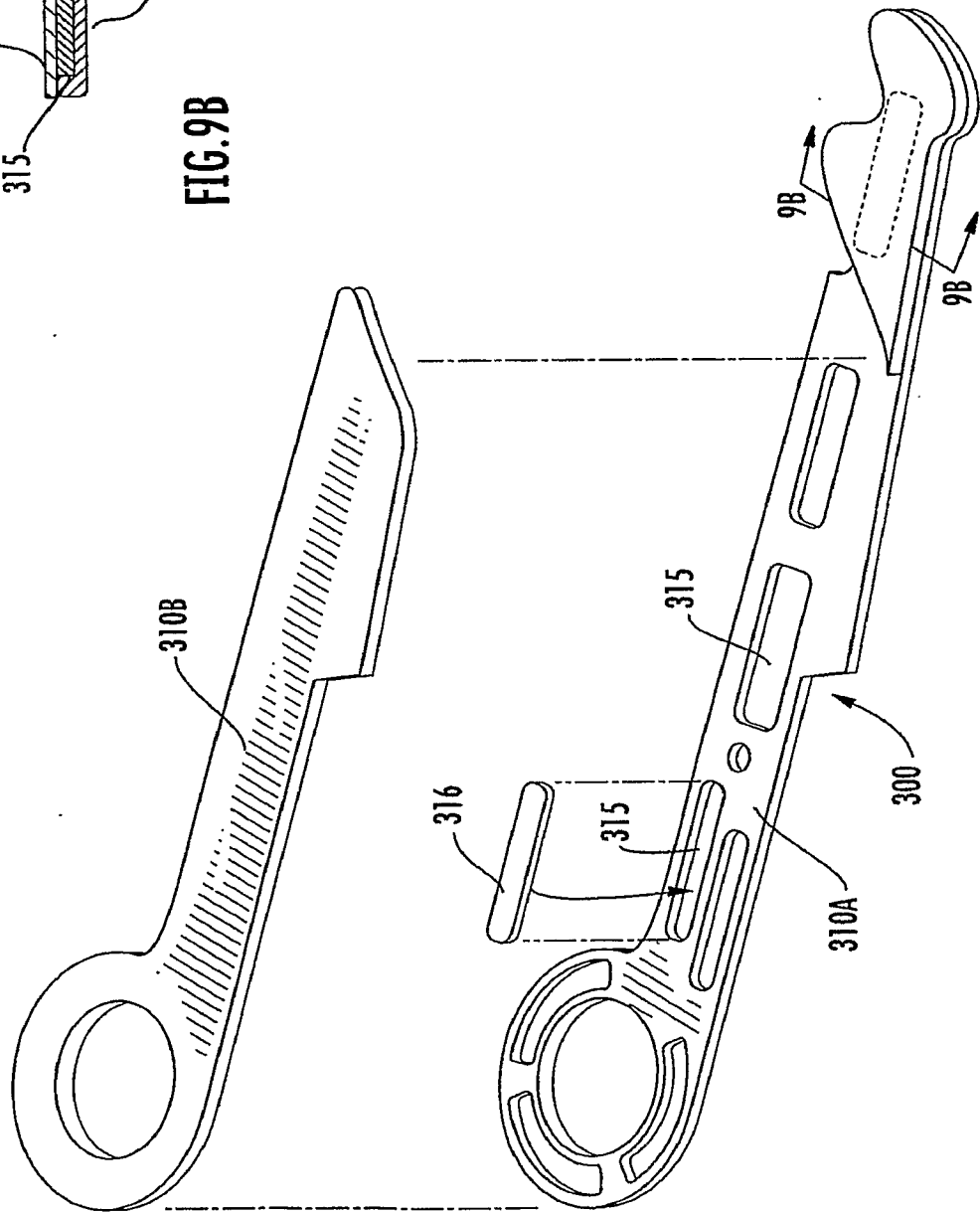
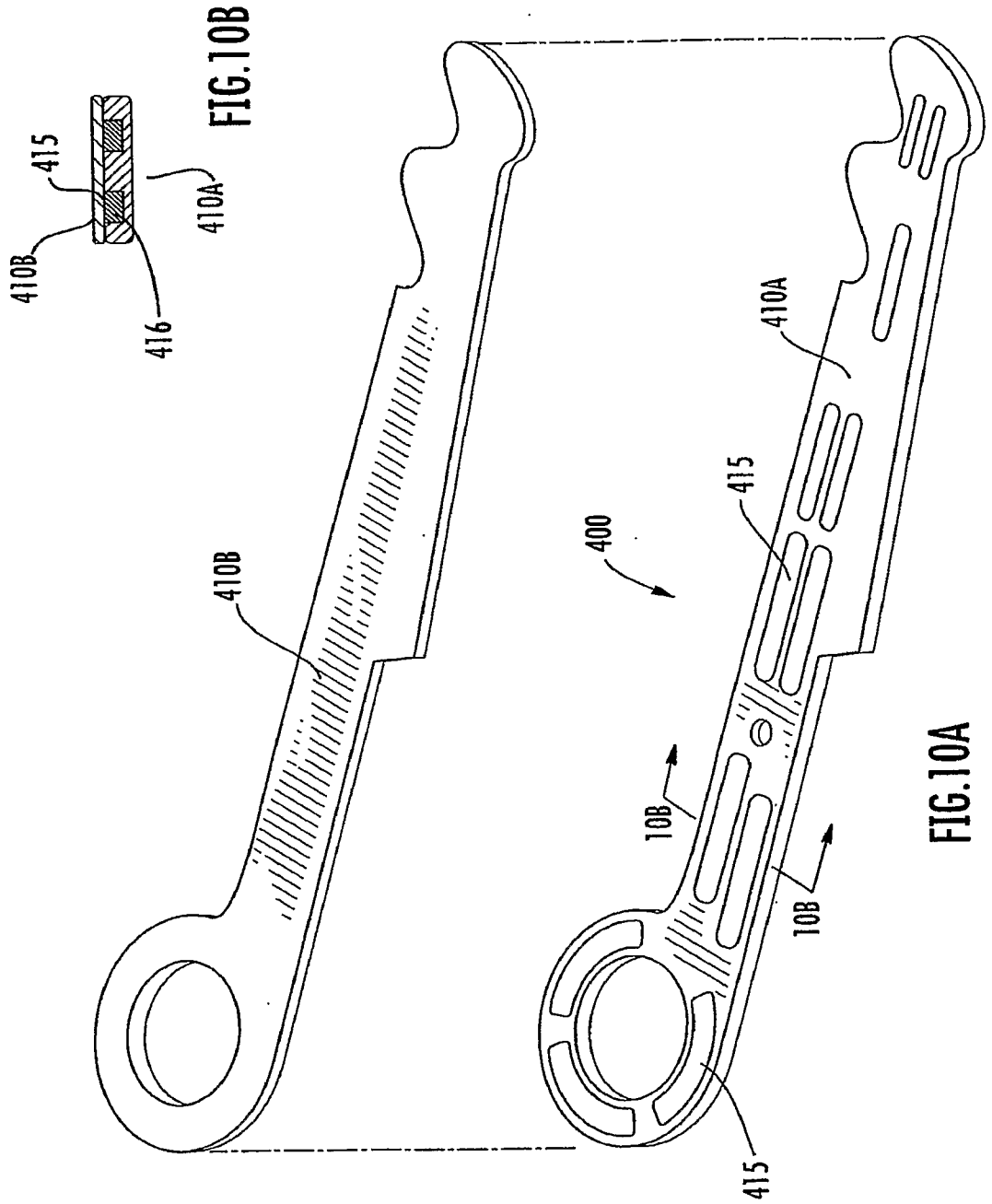

FIG. 9A



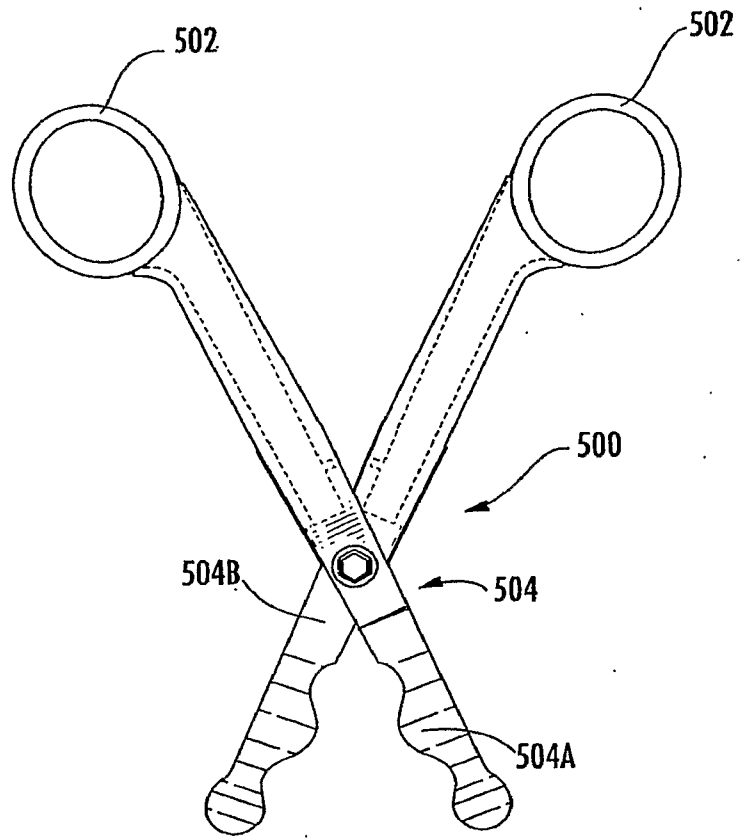

FIG. 11A

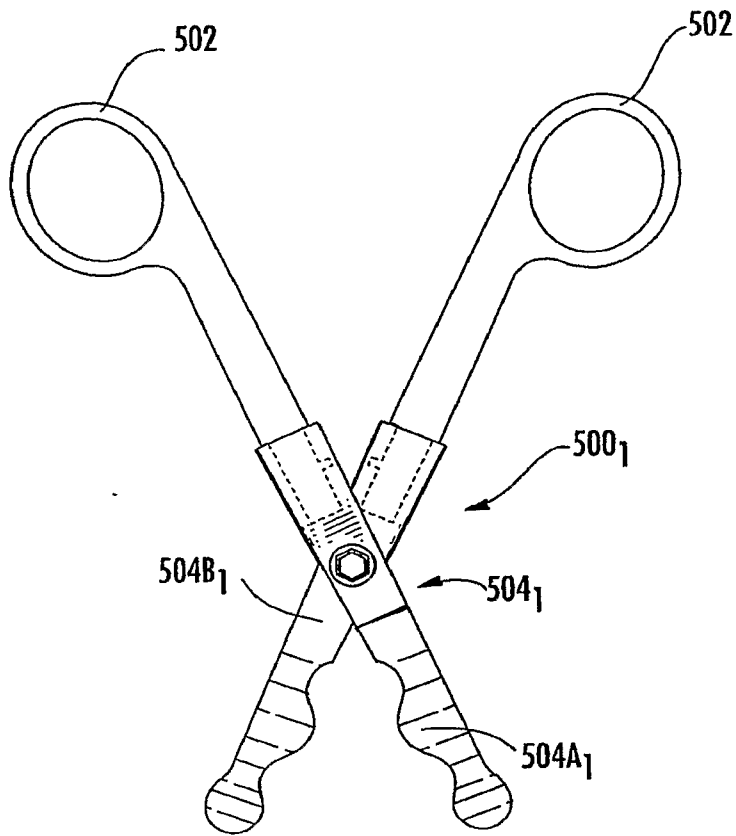

FIG. 11B

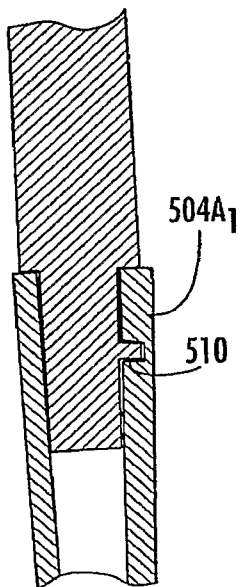

FIG. 13

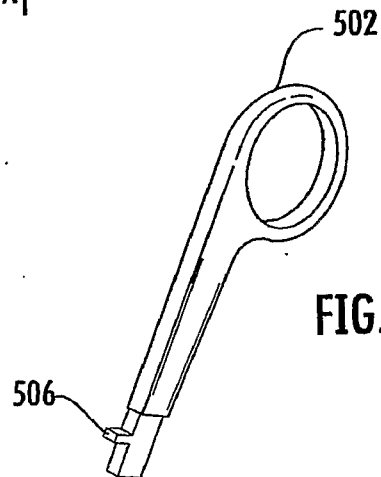

FIG. 12

