

(19) World Intellectual Property
Organization
International Bureau



(43) International Publication Date
7 April 2005 (07.04.2005)

PCT

(10) International Publication Number
WO 2005/030338 A1

- (51) International Patent Classification⁷: **A62C 13/62**, 37/12, 35/02
- (21) International Application Number:
PCT/NL2004/000599
- (22) International Filing Date: 27 August 2004 (27.08.2004)
- (25) Filing Language: Dutch
- (26) Publication Language: English
- (30) Priority Data:
1024268 11 September 2003 (11.09.2003) NL
- (71) Applicants (for all designated States except US): **CFS HOLDING B.V.** [NL/NL]; Oudendijk 64, NL-3267 LR Goudswaard (NL). **A.P. STERK BEHEER B.V.** [NL/NL]; Pieter de Hooghlaan 34, NL-3262 RE Oud-Beijerland (NL).
- (72) Inventors; and
- (75) Inventors/Applicants (for US only): **KAPTEIJN, Pieter, Cornelis** [NL/NL]; Noordeinde 11, NL-2761 BN Zevenhuizen (NL). **REIJNS, Robert, Gerardus, Cornelis** [NL/NL]; Oudendijk 64, NL-3267 LR Goudswaard (NL).
- (74) Agents: **VAN DEN HEUVEL, Henricus, Theodorus** et al.; Patentwerk B.V., P.O. Box 1514, NL-5200 BN 's-Hertogenbosch (NL).
- (81) Designated States (unless otherwise indicated, for every kind of national protection available): AE, AG, AL, AM, AT, AU, AZ, BA, BB, BG, BR, BW, BY, BZ, CA, CH, CN, CO, CR, CU, CZ, DE, DK, DM, DZ, EC, EE, EG, ES, FI, GB, GD, GE, GH, GM, HR, HU, ID, IL, IN, IS, JP, KE, KG, KP, KR, KZ, LC, LK, LR, LS, LT, LU, LV, MA, MD, MG, MK, MN, MW, MX, MZ, NA, NI, NO, NZ, OM, PG, PH, PL, PT, RO, RU, SC, SD, SE, SG, SK, SL, SY, TJ, TM, TN, TR, TT, TZ, UA, UG, US, UZ, VC, VN, YU, ZA, ZM, ZW.
- (84) Designated States (unless otherwise indicated, for every kind of regional protection available): ARIPO (BW, GH, GM, KE, LS, MW, MZ, NA, SD, SL, SZ, TZ, UG, ZM, ZW), Eurasian (AM, AZ, BY, KG, KZ, MD, RU, TJ, TM), European (AT, BE, BG, CH, CY, CZ, DE, DK, EE, ES, FI, FR, GB, GR, HU, IE, IT, LU, MC, NL, PL, PT, RO, SE, SI, SK, TR), OAPI (BF, BJ, CF, CG, CI, CM, GA, GN, GQ, GW, ML, MR, NE, SN, TD, TG).
- Published:**
— with international search report
- For two-letter codes and other abbreviations, refer to the "Guidance Notes on Codes and Abbreviations" appearing at the beginning of each regular issue of the PCT Gazette.*

(54) Title: ASSEMBLY FOR COMBATTING FIRE BY MEANS OF AEROSOL, CABINET FOR ELECTRONIC EQUIPMENT, AND METHOD OF FIRE PROTECTION

(57) Abstract: The invention relates to an assembly for combatting fire by means of supplying a radical-neutralizing aerosol, comprising: at least one holder with a starting material for generating the aerosol, activating means which co-act with the starting material and with which a conversion of the starting material into the aerosol can be initiated, and a carrier with which the holder with starting material and the activating means are assembled. The invention also relates to a cabinet for containing electronic equipment provided with such an assembly, and a method for fire protection of such a cabinet.



WO 2005/030338 A1

Assembly for combatting fire by means of aerosol, cabinet for electronic equipment, and method of fire protection

The present invention relates to an assembly for combatting fire by means of supplying
5 a radical-neutralizing aerosol. The invention also relates to a cabinet for containing
electronic equipment provided with mating means for co-action with coupling means of
electronic equipment. In addition, the invention also relates to a method for fire
protection of a cabinet for containing electronic equipment.

10 Combatting fire by means of supplying a radical-neutralizing aerosol is known in the
prior art. An example hereof is a 'FirePro® Aerosol Fire Extinguisher'. Such an aerosol
fire extinguisher comprises a holder in which is arranged, among other things, a starting
material (solid extinguishing material) which, after activation, is converted into an
aerosol. The aerosol which is generated combats fire (other than by making use of
15 conventional methods based on smothering or based on cooling) by ending the
combustion reaction on a molecular basis. The free radicals present in the fire are herein
bonded by the generated aerosol without affecting the local oxygen content. Combatting
fire by means of radical-neutralizing aerosol is relatively environmentally-friendly,
effective and efficient, so that (excessive) damage caused by extinguishing can be
20 prevented. This is particularly advantageous when combatting fire in cabinets
accommodating electronic equipment. Such cabinets are generally also designated patch
cabinets and usually contain (computer) equipment which is live and/or activated
continuously or for long periods. The space available for arranging fire protection in
and/or round such cabinets is generally limited. It is advantageous to provide such a
25 cabinet for electronic equipment with fire protection by means of aerosol. A drawback
here however is that mounting of a fire protection by means of aerosol requires
specialist skill and, once arranged, a fire protection cannot be removed easily.

The invention has for its object, while retaining the advantages of the prior art, to
30 provide an assembly for combatting fire which can be arranged in simple manner and
inexpensively in a cabinet for containing electronic equipment.

The invention provides for this purpose an assembly for combatting fire by means of
supplying a radical-neutralizing aerosol, comprising: at least one holder with a starting

material for generating the aerosol, activating means which co-act with the starting material and with which a conversion of the starting material into the aerosol can be initiated, and a carrier with which the holder with starting material and the activating means are assembled, wherein the carrier is provided with coupling means which are adapted to co-act with mating means forming part of a cabinet for mounting of electronic equipment, which mating means are adapted for mounting electronic equipment. The holder and the activating means can optionally be accommodated here in a single housing. The dimensions of the coupling means and the mating means are preferably standardized; it is for instance possible here to envisage the couplings such as are applied in standard patch cabinets of for instance 19 inches. Such patch cabinets are usually applied for the purpose of containing for instance computer equipment, communication means and switch systems. The great advantage of the present assembly is that, in very simple manner and at limited cost, it provides the option of arranging a fire protection in (and removing it from) cabinets accommodating electronic equipment. No specialist knowledge in the field of fire-fighting is required for this purpose. It is precisely in such an environment that there is an increased fire hazard. The fire protection for arranging moreover has the advantage that no special provisions need be arranged (for instance connections to public utilities are unnecessary). The proposed fire protection takes up only a limited space but still has a large extinguishing capacity, wherein it is furthermore noted that the applied extinguishing agent causes no damage to the surrounding area when used (such as the equipment located in the cabinet). The assembly according to the invention can moreover be embodied such that only very little maintenance and inspection is necessary (for instance an embodiment which is free of maintenance for 15 years).

In a preferred variant, the activating means comprise at least one sensor for fire detection. Such a sensor can for instance consist of a fire alarm (smoke detector, temperature sensor and so on) generating an electric signal. The electric signal generated by such a fire detector can be transmitted via feed wires to the activating means. It is usual to provide a fire detector generating an electric signal with a separate power supply (for instance a battery). Use can however also be made of other types of sensor, such as for instance a sensor in the form of a "thermo-cord".

The holder with starting material can be provided with an exit opening for aerosol. When the activating means initiate the conversion of the starting material into the aerosol, there occurs a considerable increase in the volume of the material. The thus obtained aerosol will have to be guided in one or more desired directions in order to carry the aerosol to the source of the fire. By arranging one or more exit openings (optionally with additional guide means for the aerosol), the aerosol can be employed optimally to combat the fire. It is conceivable here for the form and/or the location of the exit opening(s), and optionally also the form and positioning of the guide means, to be made dependent on detected signals. In another preferred embodiment, the carrier is formed by a housing in which an opening is arranged to which connects the exit opening for aerosol from the holder with starting material. The aerosol will hereby exit the housing at the position where the aerosol is desired. The housing can for instance be embodied as a substantially block-shaped construction (for instance a flat box and/or in the form of a drawer construction). It is also possible to opt for the use of a construction in which cooling means connect to an exit opening for the aerosol, so that the aerosol will arrive at a lower temperature at the location where the extinguishing effect is desired. It is also possible for the carrier to be formed by a housing in which an opening is arranged to which the sensor for fire detection connects. In a particular embodiment variant, an opening for the sensor and a passage opening for aerosol are both placed on the underside of the carrier so as to thus combine a good detection with a good extinguishing action; heat and smoke will in any case tend to rise, while the large increase in volume of the starting material to aerosol makes it possible to also urge the aerosol in downward direction. Depending on the specific conditions however, it is also possible to opt for arranging one or more openings in the top side of a housing. The possibility is also pointed out here of assembling the components of the assembly such that they are situated at some distance from each other. It is for instance possible here to envisage a carrier with a holder with a starting material and activating means to which (with some interspacing) one or more sensors are connected.

For a simple coupling of the carrier to a standard patch cabinet, the carrier is preferably provided at least at two spaced-apart positions with coupling means, wherein it is desired that the coupling means protrude from opposite sides of the carrier. In such a preferred embodiment it is moreover advantageous that the opening in the carrier onto

which an exit opening connects for aerosol from the holder with starting material is located at a distance from the coupling means.

5 In yet another variant of the assembly, the activating means comprise an electronic control system. Such a system can for instance be a time switch with which the operation of the assembly can be controlled, can comprise a delay in which a control measurement can for instance be performed after detection of a fire, and/or activating means can be arranged with which the assembly can be activated manually or remotely (optionally after detection of a fire).

10

The invention furthermore provides a cabinet for containing electronic equipment provided with mating means for co-action with coupling means of electronic equipment, wherein the cabinet is provided with an assembly for combatting fire by means of supplying a radical-neutralizing aerosol as described above, the coupling means of which assembly engage on the mating means of the cabinet. In such a cabinet can also be incorporated a discharge opening through which aerosol is discharged after the extinguishing operation has been carried out (the aerosol flow can thus be properly controlled). If the coupling means and mating means are releasably connectable, the carrier can be readily disconnected, for instance for maintenance, repair, inspection or removal of the fire protection.

20

The invention further provides a method for fire protection of a cabinet for containing electronic equipment by placing in the cabinet an assembly for combatting fire by means of supplying an aerosol neutralizing the radicals as described above, by bringing about a connection between the coupling means of the assembly and the mating means forming part of the cabinet, which mating means are adapted for mounting electronic equipment. This method also enables people having no expertise whatever in the field of fire protection to provide a cabinet for electronic equipment in reliable manner with protection.

30

The present invention will be further elucidated with reference to the non-limitative exemplary embodiments shown hereinbelow, in which:

figure 1A shows a perspective and cut-away view of an assembly for combatting fire according to the invention,

figure 1B is a bottom view of the assembly of figure 1A,
figure 2 shows a perspective and cut-away view of an embodiment variant of an
assembly for combatting fire according to the invention, and
figure 3 is a perspective view of a cabinet for containing electronic equipment according
5 to the invention.

Figure 1A shows a holder 1 for generating a radical-neutralizing aerosol. Also arranged
in holder 1 are activating means, not visible in this figure, for initiating a reaction
whereby the aerosol is obtained from a starting material arranged in holder 1. The figure
10 also shows a detector 2 with which fire can be detected (for instance a conventional
smoke detector and/or heat sensor). Detector 2 is coupled by means of a signal line 3 to
holder 1. The conversion process in holder 1 can be set into action by means of
actuation by detector 2. Holder 1 and detector 2 are both assembled in a box-like
housing 4. Housing 4 is provided on a front side 5 with indicator means 6 which are
15 connected by means of a signal line 7 to detector 2. The state of detector 2 for instance
can be visually displayed with the indicator means. Housing 4 is provided on two
opposite sides with protruding coupling means 8 with which the whole unit of holder 1,
detector 2 and housing 4 (designated as assembly 9) can be incorporated in simple
manner into a standard switch cabinet. This will be further elucidated with reference to
20 figure 3.

Figure 1B shows the underside of the assembly 9 shown in figure 1A. The underside of
housing 4 is provided with two openings 10, 11. A first opening 10 provided with a
protective grid 12 connects to the detector 2 shown in figure 1A and the second opening
25 11 connects to the holder 1 of figure 1A. Through openings 10, 11 both the detector 2
and holder 1 can communicate with the environment of assembly 9; detector 2 for
monitoring ambient conditions and holder 1 for generating aerosol.

Figure 2 shows an assembly 13, a housing 14 of which comprises a control module 15
30 in addition to the holder 1 for generating a radical-neutralizing aerosol and the detector
2 with which fire can be detected. Holder 1 and detector 2 are connected to control 15
by means of respective signal lines 16, 17. Control 15 is further connected to indicator
means 6 and an on/off switch 18. Control 15 makes it possible to synchronize the
operation of assembly 13 with diverse other equipment. It is for instance also possible to

incorporate a time delay into the operation of assembly 13 (consider for instance the possibility of manual deactivation for a short period after a fire is detected).

Figure 3 finally shows a switch cabinet 19, a door 20 of which is shown opened.

- 5 Anchored in cabinet 19 are two mounting profiles 21 on which diverse electronic equipment 22 is mounted. The equipment 22 is also provided with mutual connections 23. The equipment is coupled releasably to mounting profiles 21, which have standardized dimensions for this purpose. An assembly 24 is also arranged at the top of cabinet 19, whereby cabinet 19 is protected against fire. Assembly 24 is coupled
- 10 releasably to mounting profiles 21 in similar manner to the equipment 22. It is recommended that assembly 24 extends deeper into cabinet 19 than equipment 22 such that an exit opening for aerosol is also located in cabinet 19 at a position deeper than the rear sides of equipment 22; the aerosol will thus be able to spread relatively quickly in the (closed) cabinet 19.

15

Claims

1. Assembly for combatting fire by means of supplying a radical-neutralizing aerosol, comprising:
 - 5 - at least one holder with a starting material for generating the aerosol,
 - activating means which co-act with the starting material and with which a conversion of the starting material into the aerosol can be initiated, and
 - a carrier with which the holder with starting material and the activating means are assembled,
- 10 wherein the carrier is provided with coupling means which are adapted to co-act with mating means forming part of a cabinet for mounting of electronic equipment, which mating means are adapted for mounting electronic equipment.
2. Assembly as claimed in claim 1, characterized in that the activating means
15 comprise at least one sensor for fire detection.
3. Assembly as claimed in claim 1 or 2, characterized in that the holder with starting material is provided with an exit opening for aerosol.
- 20 4. Assembly as claimed in claim 3, characterized in that the carrier is formed by a housing in which an opening is arranged to which connects the exit opening for aerosol from the holder with starting material.
5. Assembly as claimed in any of the claims 2-4, characterized in that the carrier is
25 formed by a housing in which an opening is arranged to which connects the sensor for fire detection.
6. Assembly as claimed in any of the foregoing claims, characterized in that the carrier is provided at least at two spaced-apart positions with coupling means.
- 30 7. Assembly as claimed in claim 6, characterized in that the coupling means protrude from opposite sides of the carrier.

8. Assembly as claimed in any of the claims 3-7, characterized in that the opening in the carrier onto which an exit opening connects for aerosol from the holder with starting material is located at a distance from the coupling means.
- 5 9. Assembly as claimed in any of the foregoing claims, characterized in that the activating means comprise an electronic control system.
10. Cabinet for containing electronic equipment provided with mating means for co-
action with coupling means of electronic equipment, wherein the cabinet is provided
10 with an assembly for combatting fire by means of supplying a radical-neutralizing
aerosol as claimed in any of the foregoing claims, the coupling means of which
assembly engage on the mating means of the cabinet.
11. Cabinet as claimed in claim 10, characterized in that the coupling means and
15 mating means are releasably connectable.
12. Method for fire protection of a cabinet for containing electronic equipment, by
placing in the cabinet an assembly for combatting fire by means of supplying a radical-
neutralizing aerosol as claimed in any of the claims 1-9, by bringing about a connection
20 between the coupling means of the assembly and the mating means forming part of the
cabinet, which mating means are adapted for mounting electronic equipment.

1/2

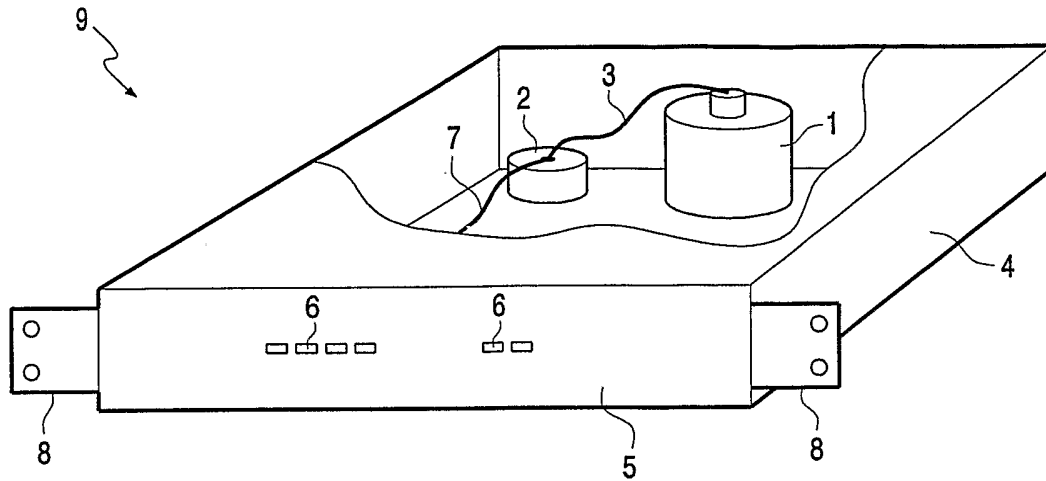

FIG. 1A

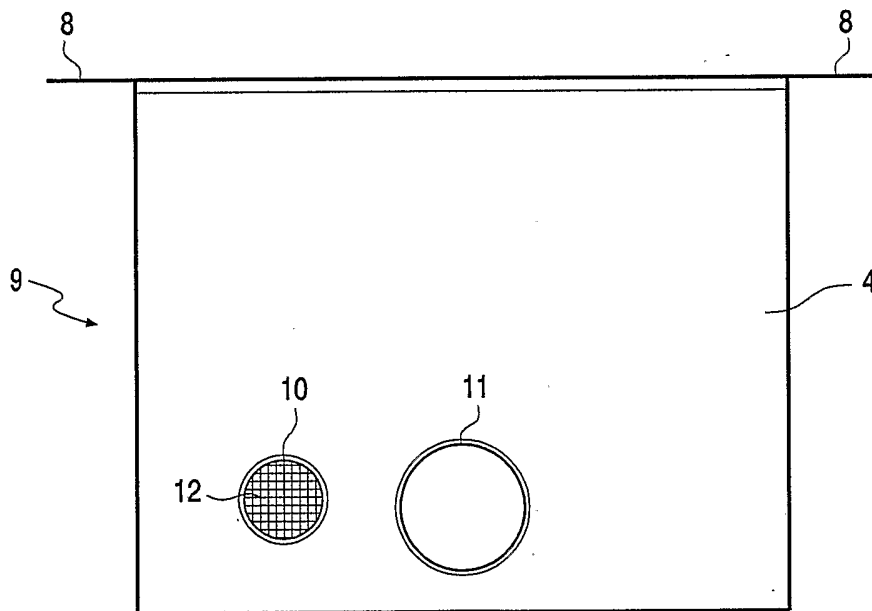

FIG. 1B

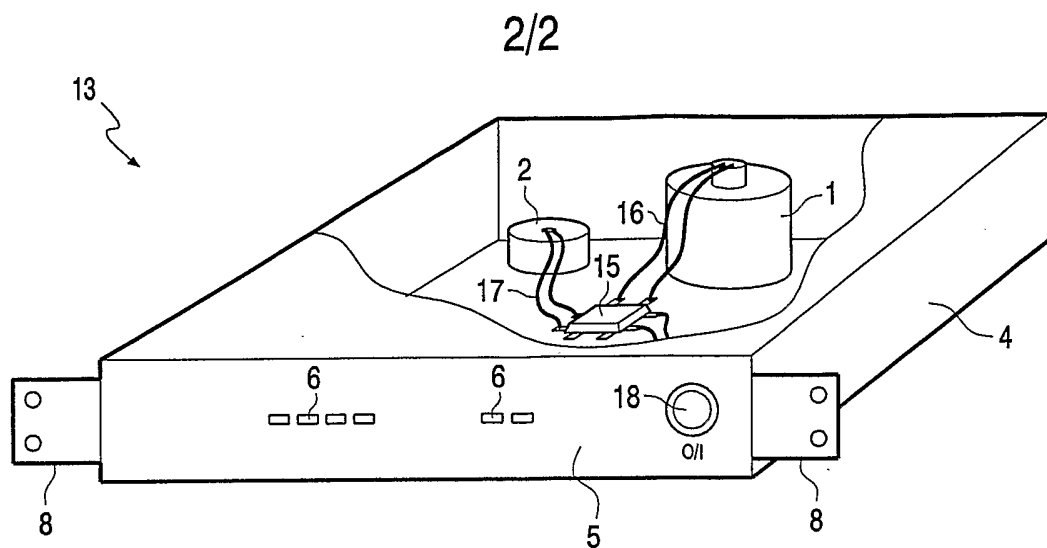

FIG. 2

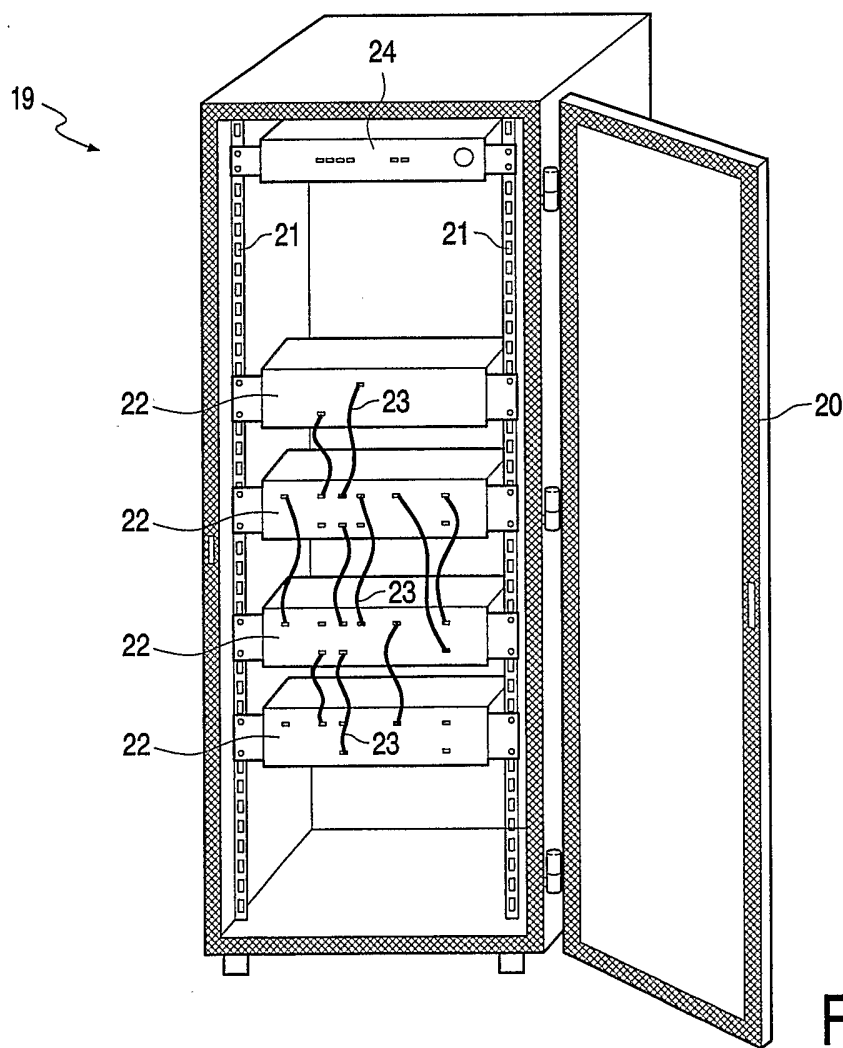

FIG. 3

INTERNATIONAL SEARCH REPORT

International Application No
PCT/NL2004/000599

A. CLASSIFICATION OF SUBJECT MATTER
IPC 7 A62C13/62 A62C37/12 A62C35/02

According to International Patent Classification (IPC) or to both national classification and IPC

B. FIELDS SEARCHED

Minimum documentation searched (classification system followed by classification symbols)
IPC 7 A62C

Documentation searched other than minimum documentation to the extent that such documents are included in the fields searched

Electronic data base consulted during the international search (name of data base and, where practical, search terms used)

EPO-Internal, WPI Data, PAJ

C. DOCUMENTS CONSIDERED TO BE RELEVANT

Category °	Citation of document, with indication, where appropriate, of the relevant passages	Relevant to claim No.
X	WO 01/62344 A (DENNE PHILLIP RAYMOND MICHAEL ; PREWER JOHN (GB); TOMORROWS DESIGN COM) 30 August 2001 (2001-08-30) the whole document	1,3,4, 11-14
Y	-----	2,5-10
Y	US 4 691 783 A (AVNI ZION ET AL) 8 September 1987 (1987-09-08) the whole document	2,5-10
X	-----	
X	GB 2 149 658 A (BARCREST LTD) 19 June 1985 (1985-06-19) the whole document	1,3, 11-15
Y	-----	4-6,8,10
Y	FR 2 523 455 A (SFEME) 23 September 1983 (1983-09-23) the whole document	4-6,8,10

Further documents are listed in the continuation of box C.

Patent family members are listed in annex.

° Special categories of cited documents :

- *A* document defining the general state of the art which is not considered to be of particular relevance
- *E* earlier document but published on or after the international filing date
- *L* document which may throw doubts on priority claim(s) or which is cited to establish the publication date of another citation or other special reason (as specified)
- *O* document referring to an oral disclosure, use, exhibition or other means
- *P* document published prior to the international filing date but later than the priority date claimed

- *T* later document published after the international filing date or priority date and not in conflict with the application but cited to understand the principle or theory underlying the invention
- *X* document of particular relevance; the claimed invention cannot be considered novel or cannot be considered to involve an inventive step when the document is taken alone
- *Y* document of particular relevance; the claimed invention cannot be considered to involve an inventive step when the document is combined with one or more other such documents, such combination being obvious to a person skilled in the art.
- *Z* document member of the same patent family

Date of the actual completion of the international search

22 December 2004

Date of mailing of the international search report

18/01/2005

Name and mailing address of the ISA

European Patent Office, P.B. 5818 Patentlaan 2
NL - 2280 HV Rijswijk
Tel. (+31-70) 340-2040, Tx. 31 651 epo nl,
Fax: (+31-70) 340-3016

Authorized officer

Neiller, F

INTERNATIONAL SEARCH REPORT

Information on patent family members

International Application No PCT/NL2004/000599
--

Patent document cited in search report		Publication date	Patent family member(s)	Publication date
WO 0162344	A	30-08-2001	GB 2359487 A	29-08-2001
			AU 3392101 A	03-09-2001
			EP 1259297 A1	27-11-2002
			WO 0162344 A1	30-08-2001
			JP 2003525668 T	02-09-2003
			US 2003168225 A1	11-09-2003
<hr style="border-top: 1px dashed black;"/>				
US 4691783	A	08-09-1987	NONE	
<hr style="border-top: 1px dashed black;"/>				
GB 2149658	A	19-06-1985	NONE	
<hr style="border-top: 1px dashed black;"/>				
FR 2523455	A	23-09-1983	FR 2523455 A1	23-09-1983
<hr style="border-top: 1px dashed black;"/>				